

**sbs**<sup>®</sup>  
GO AHEAD

HI-TECH BRAKE SOLUTIONS  
MADE IN EUROPE

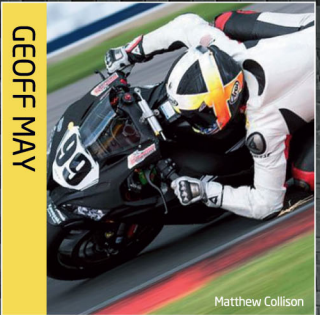

KYLE WYMAN



GEOFF MAY



KENNY COOLBETH JR



JAKE GAGNE



MATHEW SCHOLTZ

**SBS - BRAKE POWER EXCELLENCE SINCE 1964**

PASSION FOR RACING  
PASSION FOR PERFORMANCE  
PASSION FOR MOTORCYCLES

BRAKE PADS FOR ALL YOUR  
POWERSPORT NEEDS.



  [sbsamericas.com](http://sbsamericas.com)  
[sbs.dk](http://sbs.dk)

**sbs**<sup>®</sup>  
GO AHEAD

HI-TECH BRAKE SOLUTIONS  
MADE IN EUROPE

**AMERICAN**  
RACING SUCCESS



**81 MASTER CATALOG**  
**20 MOTORCYCLE AND SCOOTER BRAKE SYSTEM COMPONENTS**  
COMPOSANTS DE SYSTEME DE FREINAGE MOTO ET SCOOTERS



# HOW TO CHOOSE YOUR BRAKE PADS



## THE RIGHT CHOICE FOR YOUR MOTORCYCLE AND YOUR RIDING STYLE.

1. Choose your motorcycle type "Street Motorcycles", "V-Twin / American Motorcycles", "Off Road / Motocross", "ATV / UTV", "Road Racing", "Street use - scooter".
2. Find your "Type of use" in the matching diagram.
3. Pick the compound matching your needs and requirements.
4. Go to the "Motorcycle Model Applications" section to find your bike and matching SBS brake pad numbers.

### STREET MOTORCYCLES

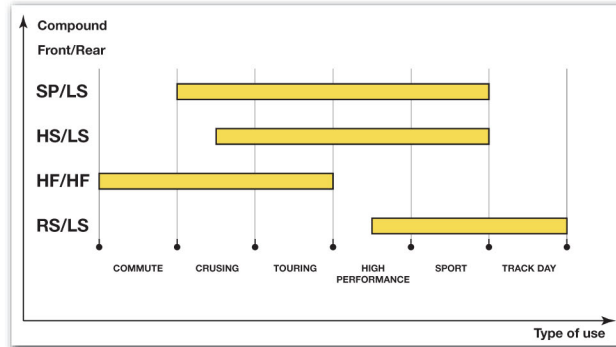

### V-TWIN / AMERICAN MOTORCYCLES

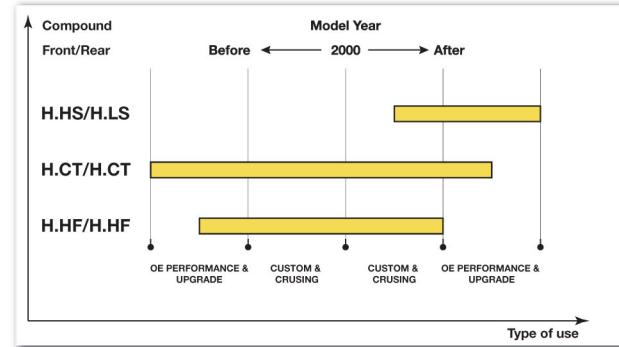

### OFF ROAD / MOTOCROSS

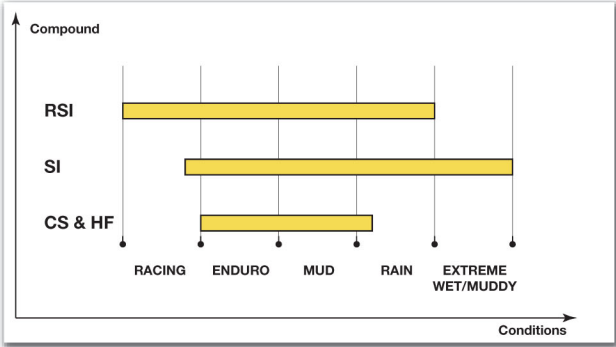

### ATV / UTV

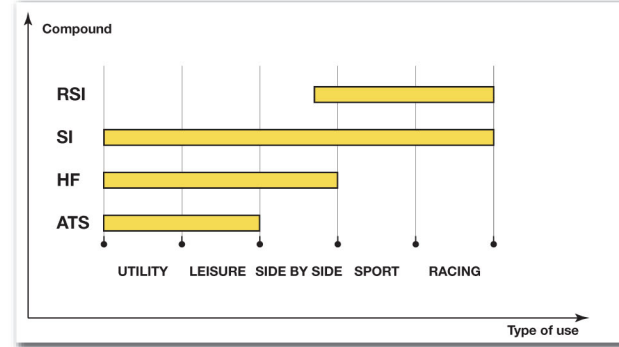

Choose ATS compound for older Arctic Cat and Polaris with plain steel discs.

### ROAD RACING

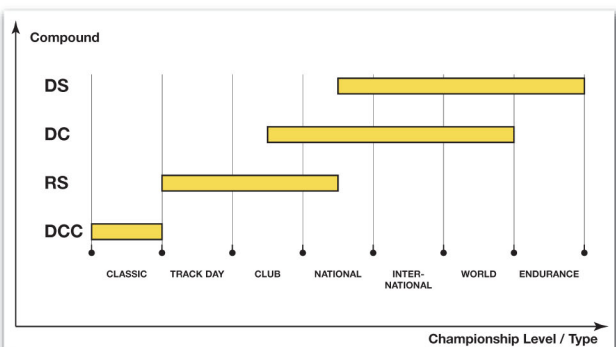

### STREET USE - SCOOTER

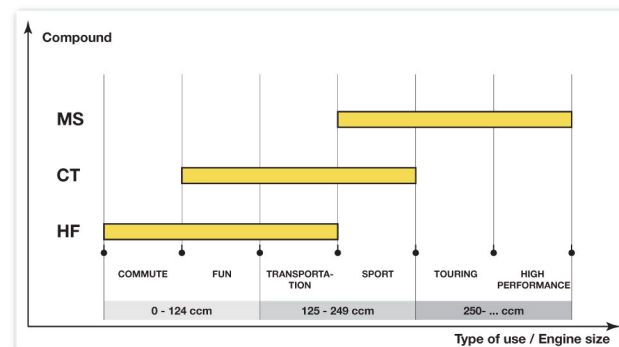

RACING SUCCESS MORE THAN 25 YEARS

Persistence  
Passion &  
Performance



Aaron Gobert • Aaron Slight • Aaron Yates • Adrian Nestrovic • Aiden Wagner • Akira Yanagawa • Alessandro Polita • Alessandro Tonucci • Alessio Corradi • Alex Barros • Alex Cudlin • Alex De Angelis • Alex Gobert • Alex Gramigni • Alex Hoffmann • Alex Schacht • Alexander Lundh • Alvaro Molina • Ana Carasco • Andi Notman • Andrew Irwin • Andrew Pitt • Andrew Stroud • Anthony Gobert • Anthony West • Arie Vos • Arne Tode • Axel Maurin • Ayrtton Badovini • Barry Veneman • Ben Bostrom • Ben Spies • Borja Sánchez • Brad Binder • Britt Turkington • Broc Parkes • Bruce Anstey • Bruno Bonhuil • Bryan Schouten • Cal Crutchlow • Cameron Beaubier • Cameron Donald • Cameron Petersen • Carl Fogarty • Carlos Checa • Chaz Davies • Chris Peris • Chris Ulrich • Chris Vermeulen • Chris Walker • Christer Lindholm • Christer Minini • Christian Gamarino • Christian Iddon • Christian Kellner • Christian Zaiser • Christoffer Bergman • Christophe Ponsson • Claudio Corti • Colin Edwards • Conor Cummins • Cory West • Craig Coxhell • Damian Cudlin • Dan Linfoot • Daniilo Petrucci • Danny De Boer • Danny Eslick • Danny Webb • David Checa • David De Gea • David Jeffries • David McFadden • David Morillon • David Salom • Davide Giugliano • Dean Ellison • Dean Harrison • Denis Sacchetti • Didier van Keymeulen • Dominique Aegerter • Doug Chandler • Doug Polen • Doug Toland • Eddi La Marra • Elena Myers • Enrique Rocamora • Eric Bostrom • Erwan Nigon • Fabien Forest • Fabio Masetti • Fabio Menghi • Fabrizio Pirovano • Federico Cariasulo • Filip Backlund • Filip Altendorfer • Florian Alt • Florian Marino • Fonsi Nieto • Fred Merkel • Freddy Foray • Gabriel Rodrigo • Gareth Jones • Gary Johnson • Gary Mason • Gary McCoy • Gary Nixon • Geoff May • Giancarlo Falappa • Gianluca Nanelli • Gianluca Vizziello • Gino Borsoi • Gino Rea • Giovanni Bussei • Glen Richards • Glenn Allerton • Glenn Irwin • Glenn Scott • Graeme Gowland • Gregorio Lavilla • Grégory Fastré • Guy Martin • Hannes Soomer • Henk van der Mark • Hikari Okubo • Hiroshi Aoyama • Hitoyasu Izutsu • Horst Saiger • Iain MacPherson • Ian Hutchinson • Ian Lougher • Ian Simpson • Igor Jerman • Igor Lecuono • Ilario Dionisi • Illia Mykhalchuk • Ivan Clementi • Ivan Goi • Jack Kennedy • Jacob Smrz • Jaimie Van Sikkelrus • Jake Gagne • Jake Zemke • James Ellison • James Haydon • James Hillier • James Rispoli • James Toseland • James Witham • Jamie Hacking • Jamie James • Jamie Robinson • Jan Hanson • Jason Pridmore • Jasper Iwema • Javier Fores • Jay Springsteen • Jed Metzger • Jeremy Guarnoni • Jeremy McWilliams • Jesco Raffin • Jim Moodie • Jimmy Filice • Jimmy Lindström • Joan Lascorz • Joan Lascorz • Joe Francis • Johan Stigefelt • John Crawford • John Crockford • John Hopkins • John Laverty • John McGuinness • John Reynolds • Jonas Folger • Jonathan Rea • Jordi Torres • Josh Brookes • Josh Hayes • Josh Waters • Joshua Day • Juan Borja • Juanfran Guevara • Jules Cluzel • Julian Puffe • Julian Simon • Julien da Costa • Julien Enjolras • Jürgen Van der Goorber • Jörg Teuchert • Kai Borre Andersen • Karl Harris • Katsuki Fujiwara • Keith Amor • Kenan Sofuoglu • Kenny Foray • Kenny Noyes • Kevin Coghlan • Kevin Curtan • Kevin Valk • Kevin Wahr • Koen Meuffels • Kurtis Roberts • Kyle Ryde • Kyle Smith • Kyle Wyman • Leandro Mercado • Lee Johnston • Leon Camier • Leon Haslam • Livio Loi • Lorenzo Lanzi • Lorenzo Zanetti • Loris Baz • Luca Marconi • Luca Scassa • Lucas Mahias • Luis Salom • Lukas Pezek • Lukas Trautmann • Marc Moser • Marcel Kellenberger • Marco Faccani • Maria Herrera • Mark Aitchinson • Mark Heckles • Markus Reiterberger • Martin Cardenas • Martin Jessop • Marvin Fritz • Massimo Roccoli • Mat Mladin • Matej Smrz • Mathew Scholtz • Mathieu Gines • Matteo Baiocco • Matthieu Lagrive • Mauro Sanchini • Maverick Vináles • Max Neukirchner • Maxime Berger • Melissa Paris • Michael Barnes • Michael Canducci • Michael Dunlop • Michael Laverty • Michael Rutter • Michael Savary • Michael Schulten • Michael van der Mark • Michel Fabrizio • Michele Pirro • Michelle Malatesta • Miguel Duhamel • Miguel Praia • Mika Kallio • Mika Pérez • Mike Di Meglio • Mike Edwards • Mike Hale • Mike Smith • Nacho Calero • Neil Hodgson • Nial McKenzie • Niccolò Canepa • Nicky Hayden • Niki Tuuli • Nina Prinz • Norick Abe • Ondrej Jezek • Patric Muff • Paul Young • Pedro Vallcaneras • Pere Riba • Peter Goddard • Peter Linden • Peter Oettl • Philipp Hafenegger • Philipp Oettl • Pier Francesco Chili • Piergiorgio Bontempi • P.J. Jacobsen • Raffaele De Rosa • Ralf Waldmann • Randy Krummenacher • Rathapark Wilairot • Raymond Roche • Remy Gardner • Ricardo Chiarello • Riccardo Russo • Richard Cooper • Rob Hartog • Rob McElnea • Robbin Harms • Robert Schotman • Robert Ulm • Roberto Rolfo • Roberto Tamburini • Robin Mulhauser • Roger Lee Hayden • Roman Stamm • Ronald Ten Brake • Roy Ten Napel • Ruben Xaus • Ryan Vos • Ryuichi Kiyonari • Sam Lowes • Sandro Cortese • Santiago Barragan • Scott Deroué • Scott Redding • Scott Russell • Sean Emmet • Sebastian LeGrelle • Sebastian Scarnato • Sébastien Gimbert • Sébastien Suchet • Shane Byrne • Sheridan Morais • Shinichi Nakatomi • Shinya Nakano • Simon Crafar • Simone Sanna • Stefan Bradl • Stefan Kerschbaumer • Stefan Nebel • Stephane Chambon • Stephane Mertens • Steve Hislop • Steve Martin • Steve Mercer • Steve Plater • Steve Rapp • Stuart Easton • Sylvain Barrier • Sylvain Guintoli • Tage Solberg • Tarran Mackenzie • Tatsuki Suzuki • Tatu Lauslehto • Taylor Mackenzie • Terry Rymmer • Thomas Stevens • Tito Rabat • Tom Kipp • Tom Luthi • Tom Sykes • Tom Tunstall • Tommy Bridewell • Tommy Hayden • Tommy Hill • Toni Finsterbusch • Toni Sharpless • Tony Covena • Toprak Razgatlioglu • Travis Wyman • Troy Bayliss • Troy Corser • Vesa Kallio • Vincent Haskovec • Vincent Lonbois • Vittorio Iannuzzo • Walter Tortoroglio • Warwick Nowland • Wayne Maxwell • Wayne Tessels • Werner Daemen • Wes Cooley • William De Angelis • William Dunlop • Xavier Simeon • Yoann Tiberio • Yonny Hernandez • Yukio Kagayama • Zulfahmi Khairuddin ...and many more.







# CONTENT

2 – 3	<b>WELCOME TO OUR UNIVERSE</b>
4 – 6	<b>UNIQUE TECHNOLOGY FEATURES</b>
7 – 9	<b>STREET BRAKE PADS</b>
8	HS/LS – <i>Street Performance</i>
9	SP – <i>Street Upgrade</i>
9	HF – <i>Street Standard</i>
11 – 13	<b>AMERICAN BRAKE PADS</b>
12	H.HS/H.LS – <i>High Performance &amp; No Dust</i>
13	H.CT – <i>High Power &amp; Noise Reduction Formula</i>
13	H.HF – <i>Ultra Quiet &amp; Low Dust</i>
15 – 17	<b>SCOOTER BRAKE PADS</b>
16	MS – <i>Maxi Sinter</i>
16	CT – <i>Standard &amp; Maxi</i>
17	HF – <i>Standard &amp; Maxi</i>
19 – 22	<b>RACING BRAKE PADS</b>
20	DS – <i>Road Racing &amp; Endurance</i>
20	DC – <i>Endurance, Classic &amp; Road Racing</i>
21	DCC – <i>Endurance, Classic &amp; Road Racing</i>
21	RS – <i>Road Racing &amp; Track Days</i>
22	RQ – <i>Endurance, Classic &amp; Road Racing</i>
22	LS – <i>Endurance, Classic &amp; Road Racing</i>
23 – 25	<b>OFF ROAD &amp; ATV BRAKE PADS</b>
24	RSI – <i>Racing</i>
24	SI – <i>Club, Trails &amp; Leisure</i>
25	CS – <i>Club, Trails &amp; Leisure</i>
25	ATS – <i>Club, Trails &amp; Leisure</i>
26	<b>BRAKE SHOES WITH SPRINGS</b>
27	<b>STAINLESS BRAKE PINS</b>
28	<b>ACCESSORIES – BRAKE SYSTEM BLEEDER &amp; ANTI-NOISE SHIMS</b>
29 – 31	<b>MERCHANDISE</b>
32	<b>SALES &amp; POS MATERIAL</b>
33	<b>MOTORCYCLE MODEL APPLICATIONS</b>
34	<i>Motorcycles, Off Road, ATV, Scooters</i>
95	<i>Motocross</i>
99	<i>Racing</i>
105	<i>Calipers</i>
109	<b>BRAKE PAD 1:1 DRAWINGS, COMPOUNDS, FITMENTS</b>
621	<b>CROSSLIST BRAKE PADS: SAME SHAPE – DIFFERENT THICKNESS</b>
625	<b>BRAKE SHOE DRAWINGS, FITMENTS</b>
677	<b>CROSS REFERENCE LIST – OTHER BRANDS</b>
689	<b>BRAKE PIN FITMENTS, DRAWINGS</b>

Complete copies or extracts of this catalogue only with permission by SBS Friction A/S.  
The right to make modifications of the design or model application is reserved.  
Every effort has been made to ensure correctness of the information contained in this catalogue. However we shall not be responsible for any loss arising from errors or omissions made.

Aucune copie, intégrale ou partielle du présent catalogue n'est possible sans l'autorisation expresse de la société SBS Friction A/S. Droit de modification des constructions et applications de modèles réservé.  
Tout est mis en œuvre pour garantir l'exactitude des informations contenues dans ce catalogue. Cependant, nous ne saurions être tenus responsables des pertes subies suite à des erreurs ou des omissions.

## WELCOME TO OUR UNIVERSE



SBS Friction A/S is a Danish based company that develops, produces and markets brake pads and friction solutions for motorcycles, scooters, ATV/UTVs, special cars and industrial applications including wind turbines.

Further, our product range includes other brake components such as brake rotors, brake shoes, and accessory parts such as brake pins.

Our history goes back to 1964. In the 1970s we were the first to introduce aftermarket disc brake pads for motorcycles. Since then we have continuously expanded our range, and our market coverage is almost complete no matter make, model or year. We are first with the newest and last with the oldest.

We are number one 1 in the European aftermarket for motorcycle brake pads, and all over the globe the SBS name is known for braking excellence. Totally, our distribution network is spread to around 50 countries around the world including the USA, Canada, Japan, Australia and the European Union.

Our customer portfolio comprises motorcycle industry OEMs such as brake system and vehicle manufacturers, and due to our friction know-how other industries such as wind turbines manufacturers.

Our headquarters, R&D, production and sales are located in Svendborg, Denmark. Our production plant features around 12,000 sqm with production lines for ceramic, sintered and carbon material components.

We employ around 200 people and our turnover has increased steadily since we introduced our first brake pad.

## BIENVENUE DANS NOTRE UNIVERS



SBS Friction A/S est une société danoise qui développe, produit et commercialise des plaquettes de frein et des solutions de friction pour les motos, les scooters, les quads ou autres véhicules TT, les véhicules spéciaux et les applications industrielles comme les éoliennes.

Notre gamme de produits comprend en outre d'autres composants de freinage comme les disques de frein et les segments de frein, mais aussi des accessoires comme les axes de frein.

Notre histoire a commencé en 1964. Dans les années 1970, nous avons été les premiers à proposer des plaquettes de frein de rechange pour les motos. Depuis, nous avons continué à développer notre gamme et notre couverture du marché est aujourd'hui pratiquement totale, quels que soient la marque, le modèle ou l'année. L'innovation est notre marque de fabrique !

Nous sommes numéro un sur le marché européen du rechange en matière de plaquettes de frein pour les motos et la marque SBS est synonyme d'excellence de freinage partout dans le monde. Au total, notre réseau de distribution est présent dans près de 50 pays répartis sur toute la planète, y compris aux États-Unis, au Canada, au Japon, en Australie et dans l'Union Européenne.

Notre portefeuille de clients regroupe des OEM du marché de la moto comme des fabricants de systèmes de freinage et des constructeurs automobiles, mais aussi, grâce à notre savoir-faire en matière de friction, des constructeurs d'éoliennes.

Notre siège social, notre service R&D, notre site de production et notre service commercial se trouvent à Svendborg, au Danemark. Notre site de production s'étend sur près de 12 000 m<sup>2</sup> et nos chaînes produisent des composants en céramique, frittés ou en carbone.

Nous employons près de 200 personnes et notre chiffre d'affaire n'a fait qu'augmenter avec une belle régularité depuis la production de nos premières plaquettes de frein.





## WELCOME TO OUR UNIVERSE



### FRICION IS TOO IMPORTANT TO LEAVE TO OTHERS

Therefore we manage all crucial processes, such as product development, testing, mixing, pressing, controlling, packing etc. "in-house".

We consider innovation, productivity and quality assurance our core competences.

We continuously develop new friction materials, new products, new production methods and advanced process technology. Our production lines are state-of-the-art and our operations highly automated.

All workflows are LEAN based, focusing strictly on the needs of our customers for high and consistent quality, full flexibility and excellent delivery performance. Our experienced and well trained staff ensures high efficiency in all processes, from compound mixing to packing.

Our R&D continuously innovates with new materials and technologies to achieve ultimate performance, longer lifetime, higher comfort and more eco-friendly brake products.

We meet the requirements of both aftermarket and OE customers, and our products are approved accordingly.

#### Our mission is clear:

To develop today's state-of-the-art brake parts and set the standards for tomorrow's brake technology.



## BIENVENUE DANS NOTRE UNIVERS



### LA FRICTION EST UN ÉLÉMENT TROP IMPORTANT POUR LE CONFIER À D'AUTRES

C'est pourquoi nous gérons en interne tous les processus critiques, du développement des produits aux tests, au mélange et au pressage, en passant par le contrôle et l'emballage.

Pour nous, l'innovation, la productivité et l'assurance qualité sont des compétences clés.

Nous développons en permanence de nouveaux matériaux de friction, de nouveaux produits, de nouvelles méthodes de production et de nouvelles technologies. Nos lignes de production sont à la pointe de la technologie et toutes nos opérations sont hautement automatisées.

Tous nos flux de travail s'appuient sur le concept LEAN et se concentrent strictement sur les besoins de nos clients pour garantir une qualité supérieure en toutes circonstances, une flexibilité totale et des performances de livraison exceptionnelles. Nos équipes expérimentées et hautement qualifiées assurent un rendement optimal de tous les processus, du mélange des composés à l'emballage.

Les innovations permanentes de notre service R&D, tant en termes de matériaux que de technologies, permettent d'atteindre des performances exceptionnelles, des durées de vie prolongées, un confort accru et de fabriquer des produits de freinage respectueux de l'environnement.

Répondant aux besoins à la fois du marché de la 2ème monte et de l'équipement d'origine, nos produits sont tous homologués.

#### Notre mission est claire :

Développer des pièces de freinage à la pointe de la technologie d'aujourd'hui et définir les standards de la technologie de freinage de demain.





## UNIQUE TECHNOLOGY FEATURES



### NRS TECHNOLOGY (NUCAP RETENTION SYSTEM)

In order to attach a ceramic/organic friction material to the backing plate, a type of adhesive is normally used. This adhesive needs to be very temperature stable, due to the elevated temperature which is measured in a brake system. Furthermore, the appliance of the adhesive needs to be controlled very carefully in order to make sure that a consistent shear strength is achieved. However, no matter how good this is done there will always be an upper temperature limit where the adhesive will start to decompose and the risk of having a delamination between the back plate and the friction material will increase significantly.

NRS is used for a variety of compound types made by SBS including street, off-road and racing compounds.

NRS technology is based on a matrix of hooks raised on the backing plate that mold into the friction material, creating an indestructible mechanical bond without any use of adhesives. The main advantages of NRS technology compared to traditional methods are:

- // No separation between back plate and friction material
- // No lifting edges of the friction material giving a firm lever feel
- // No vibration between the friction material and backing plate

### CERAMIC/ORGANIC PRODUCTION TECHNOLOGY

Ceramic/organic materials are mainly used for smaller motorcycles and scooters, but used to be the dominating brake material type.

The ceramic/organic friction material powder is fed into a hot cavity and pressure is applied together with the backing plate featuring NRS retention technology. Due to a glue being mixed in the friction powder, it reacts and creates the bond. After a certain time in the hot cavity the pad, including the back plate, is ejected and sent to a curing station, where the final curing of the friction material takes place.



## DES TECHNOLOGIES UNIQUES



### TECHNOLOGIE NRS (NUCAP RETENTION SYSTEM)

Pour fixer le matériau de friction céramique/organique sur le support, on utilise généralement un certain type d'adhésif. Cet adhésif doit être caractérisé par une grande stabilité thermique, en raison de la température élevée d'un système de freinage. De plus, l'application de l'adhésif doit être soigneusement contrôlée pour assurer une résistance au cisaillement uniforme. Pourtant, quel que soit l'adhésif et la procédure utilisés, il existe toujours une limite de température au-delà de laquelle l'adhésif commence à se décomposer, entraînant un fort risque de délaminage entre le support et le matériau de friction.

SBS ne souhaitant faire aucun compromis en matière de sécurité des pilotes, la technologie NRS est utilisée pour tous les matériaux de friction céramiques/organiques actuellement fabriqués par SBS, y compris les composés destinés aux motos routières, tout terrain et de course.

Cette technologie est également utilisée pour certains types de plaquettes frittées (voir la section « Frittage conducteur »).

La technologie NRS est basée sur une matrice de crochets sur le support, qui viennent se mouler dans le matériau de friction, créant ainsi une liaison mécanique indestructible sans utiliser d'adhésif. Par rapport aux méthodes traditionnelles, les principaux avantages de la technologie NRS sont les suivants :

- // Absence de séparation entre le support et le matériau de friction
- // Absence de bords susceptibles de se soulever sur le matériau de friction et de provoquer un effet de levier
- // Absence de vibrations entre le support et le matériau de friction

### TECHNOLOGIE DE PRODUCTION CÉRAMIQUE/ORGANIQUE

Les matériaux céramiques/organiques sont aujourd'hui principalement utilisés pour les petites motos et les scooters, mais ils étaient auparavant le type de matériau le plus fréquemment utilisé.

Une poudre de matériau de friction céramique/organique est d'abord placée dans une cavité très chaude, puis une pression est exercée sur le support doté de la technologie NRS. Grâce à la colle intégrée à la poudre de friction, la réaction chimique qui se produit entraîne la création du matériau de friction. Après être restée quelques temps dans la cavité brûlante, la plaquette, y compris le support, est éjectée et envoyée dans une station de durcissement, où le matériau de friction finit de durcir.

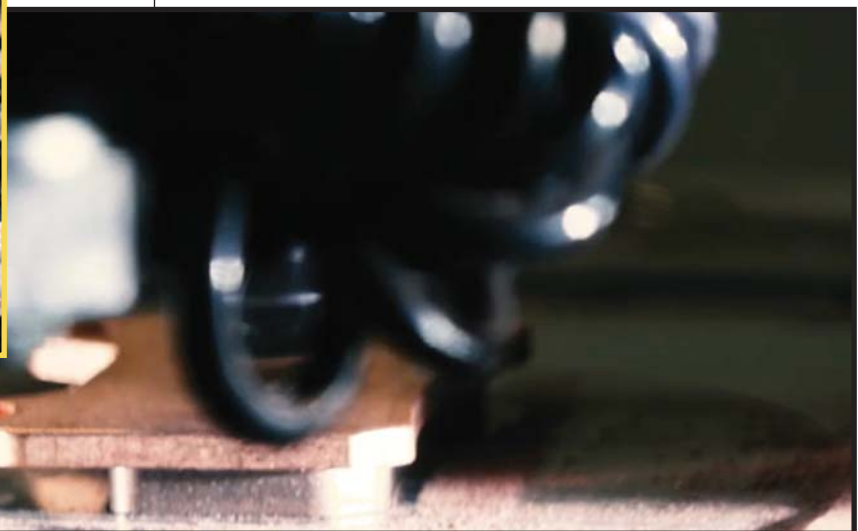



## UNIQUE TECHNOLOGY FEATURES



### SINTERING PRODUCTION TECHNOLOGY

Many new motorcycles are equipped with sintered brake pads.

SBS uses two basic methods for sintering of friction materials:

#### Sintering in open belt furnace

Sintering of friction materials is very different compared to hot pressing of ceramic/organic friction materials. Typically, the pressure used for sintered friction materials is 10 times higher compared to ceramic/organic friction materials.

In the sintering process the friction material slowly moves through an open belt furnace, where it is heated to 800°C, or more. During the time in the furnace, the metal particles melt together and creates a metal matrix - known as sintering. Within this metal matrix there are inclusions of abrasive or lubricating particles, which at the end creates the friction material. SBS brake pads produced in an open belt furnace are either brazed to the backing plate or feature NRS technology for adhesion.

#### Conductive sintering

Conductive sintering or direct hot pressing is a technology based on the principle of heating up the material by electrical current. The advantages of this method is that it is very easy to control the sintering process resulting in an excellent and consistent brake pad material quality.

For conductive sintered products, NRS retention technology is used.

## DES TECHNOLOGIES UNIQUES



### TECHNOLOGIE DE PRODUCTION DU FRITTAGE

Nombreuses sont les motos récentes qui sont équipées de plaquettes de frein frittées.

Pour le frittage des matériaux de friction, SBS utilise deux méthodes de base :

#### Frittage au four à tapis ouvert

Le frittage des matériaux de friction est très différent du pressage à chaud des matériaux de friction céramiques/organiques. Généralement, la pression utilisée pour fritter les matériaux de friction est 10 fois supérieure à celle utilisée pour les matériaux de friction céramiques/organiques.

Lors du processus de frittage, le matériau de friction se déplace lentement à travers un four à tapis ouvert, où il est chauffé à 800 °C ou plus. Durant le passage dans le four, les particules métalliques fondent et forment une matrice métallique. Ce processus est appelé frittage. Cette matrice métallique comprend des inclusions de particules abrasives ou lubrifiantes qui forment le matériau de friction. Les plaquettes de frein SBS produites dans un four à tapis ouvert sont alors brasées sur le plateau de frein ou assemblées à l'aide de la technologie d'adhérence NRS.

#### Frittage conducteur

Le frittage conducteur, ou pressage à chaud direct, est une technologie qui consiste à chauffer le matériau par un courant électrique. Les avantages de cette méthode sont qu'elle permet de contrôler facilement le processus de frittage et d'obtenir une qualité de matériau homogène et excellente.

Pour les produits frittés conducteurs, on utilise la technologie d'assemblage NRS.

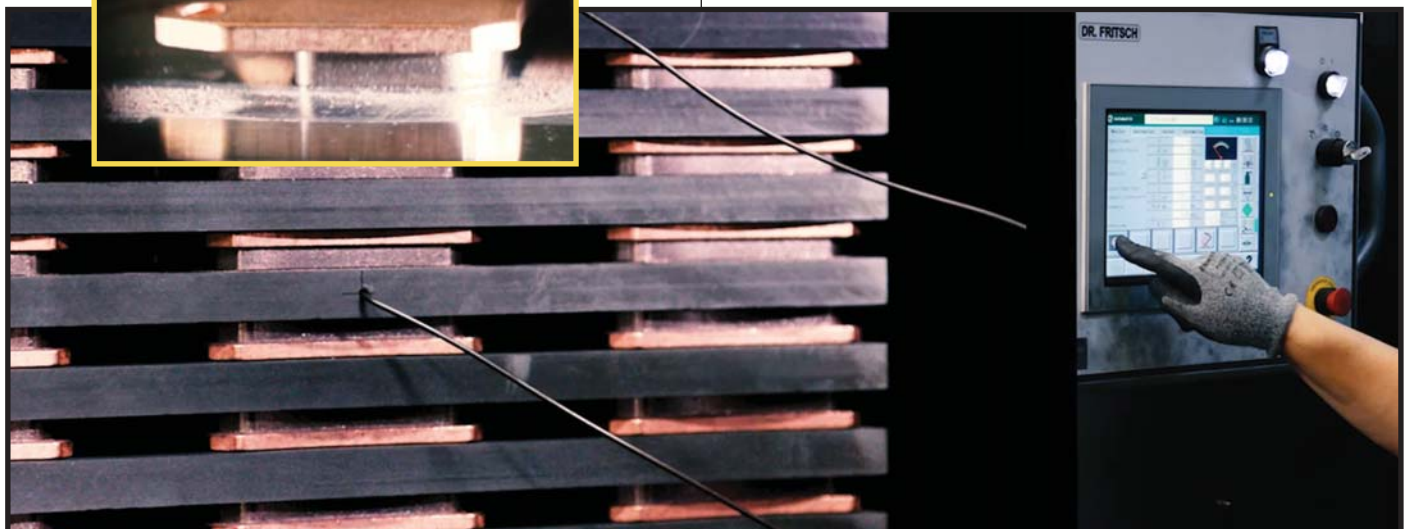
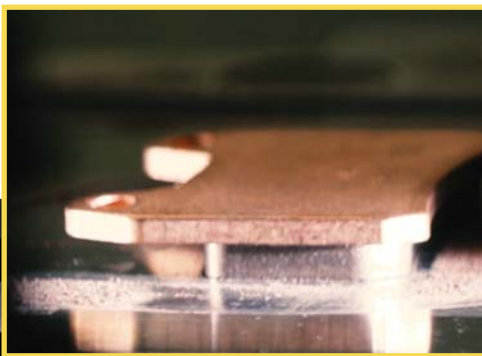



## UNIQUE TECHNOLOGY FEATURES



### DEST

DEST technology means Dynamic Energy Surface Treatment. Used for DC racing compounds to ensure consistent fade-free performance from SBS production line. No thermal bedding-in is needed due to the DEST process which ensure degassing of the material to eliminate a gaseous film being created between rotor and pad surface to cause a loss of brake power (fade).

During the DEST scorching process the surface of the friction material is heated to around 700°C (1292°F). This means that a part of the pad is now decomposed to a certain depth and the amount of gases that will come out of the friction surface is reduced significantly.

### COATING

SBS only uses coating materials and methods that protect the brake pads optimally against corrosion.

#### Ceramic/organic pads:

Powder coating with temperature stability up to 200-300°C

#### Sintered/carbon pads:

Copper - temperature stability of 900°C

Chromium-Nickel – temperature stability of 900°C.

The thickness of the metallic coatings is typically 10-15 µm. Corrosion-testing is performed with according to the ISO 9227 NSS.

## DES TECHNOLOGIES UNIQUES



### DEST

La technologie DEST signifie Dynamic Energy Surface Treatment (traitement de surface à énergie dynamique). Utilisée pour les composés DC Racing, elle garantit des performances d'une fiabilité absolue dès la ligne de production SBS. Aucun rodage thermique n'est nécessaire grâce au processus DEST, qui assure un dégazage du matériau afin de supprimer le film gazeux qui se forme entre le disque et la surface de la plaquette et est susceptible d'altérer la puissance de freinage (fading).

Au cours du processus de vulcanisation DEST, la surface du matériau de friction est chauffée à environ 700 °C (1 292 °F). Ceci signifie qu'une partie de la plaquette est décomposée jusqu'à une certaine profondeur et que le volume de gaz qui se dégage de la surface de friction est réduit de manière significative.

### REVÊTEMENT

SBS utilise uniquement des matériaux et des méthodes de revêtement qui protègent efficacement les plaquettes de frein de la corrosion.

#### Plaquettes céramiques/organiques :

Revêtement en poudre avec stabilité thermique jusqu'à 200-300 °C

#### Plaquettes frittées/en carbone :

Cuivre – stabilité thermique de 900 °C

Nickel-Chrome – stabilité thermique de 900 °C

L'épaisseur des revêtements métalliques est généralement de 10-15 µm. Les tests de corrosion sont effectués conformément à la norme ISO 9227 NSS.

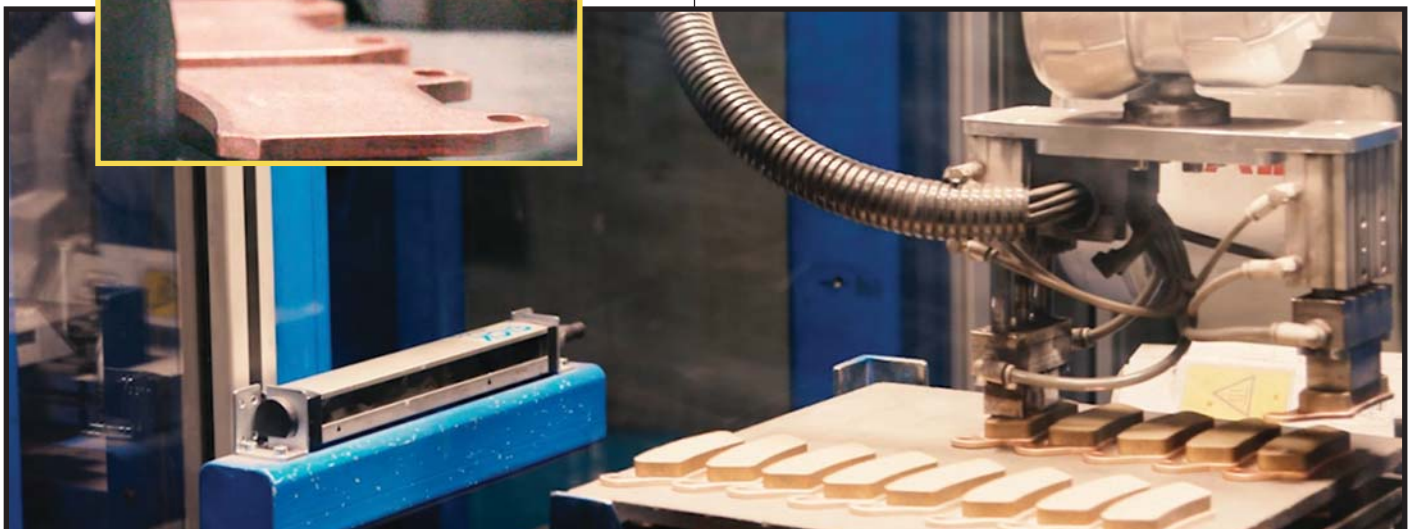
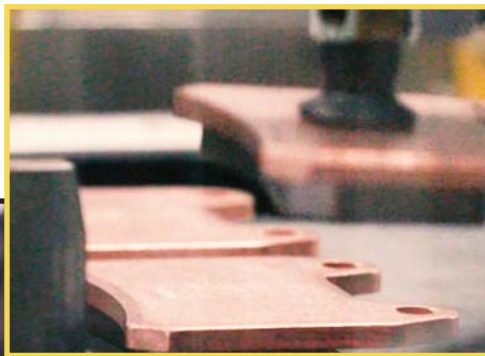



# LICENSE TO ADVENTURE



If a street bike is the best thing you own. If you are dedicated to touring and adventures on weekends and holidays. If you enjoy the freedom of motorcycle riding. Or if you are commuting every day.

Then SBS STREET brake pads are the right choice for you. Our STREET compounds are developed to match all makes, models and age of street bikes on the market – front and rear.

They give you the performance, lifetime and comfort that you need to GO AHEAD.

Choose between:  
// PERFORMANCE – HS / LS  
// UPGRADE – SP  
// STANDARD – HF

Follow our recommendations for the ideal pads for your bike.



Si votre moto de route est votre meilleure alliée. Si vous êtes friand de randonnées et d'aventures à moto pendant les week-ends et les vacances. Si vous aimez la liberté qu'offre la conduite d'une moto. Ou simplement si vous allez tous les jours travailler en moto.

Alors les plaquettes de frein SBS STREET sont faites pour vous. Nos composés STREET ont été développés pour s'adapter à toutes les marques, tous les modèles et toutes les générations de motos routières du marché, à l'avant comme à l'arrière.

Elles vous offrent les performances, la longévité et le confort dont vous avez besoin pour ALLER PLUS LOIN.

Choisissez entre les versions :  
// PERFORMANCE – HS / LS  
// UPGRADE – SP  
// STANDARD – HF

Suivez nos recommandations pour trouver les plaquettes idéales pour votre moto.

**sbs**<sup>®</sup>  
GO AHEAD





# PERFORMANCE



## HS - SINTER

FRONT / AVANT



- // OE replacement compound for bikes with sintered pads
- // Designed for modern high performance, sport, big touring and adventure bikes
- // Sintered compound formulated for low wear, high thermal stability, excellent brake feel and easy modulation
- // HH rated performance, developed in racing and fine-tuned for street use
- // Excellent for stainless steel or cast iron brake rotors
- // Front (HS) and rear (LS) compounds for ideal brake balance, to avoid rear wheel lock-up



- // Composé de rechange Haute Performance pour motos équipées d'origine de plaquettes frittées.
- // Conçu pour les motos modernes hautes performances sportives, routières ou destinées à l'aventure
- // Composé fritté formulé pour une faible usure, une stabilité thermique élevée, une excellente sensation de freinage et une modulation facile.
- // Composé aux performances supérieures exceptionnelles, conçu pour la compétition et la route.
- // Idéalement adapté aux disques de frein en acier inoxydable ou en fonte
- // Composés avant (HS) et arrière (LS) offrant un équilibre de freinage parfait pour supprimer le risque de blocage de la roue arrière

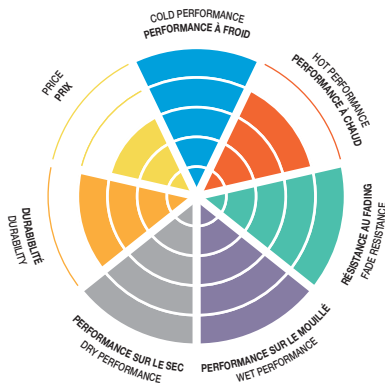

Brake performance diagrams to be compared individually within STREET compounds only.



## LS - SINTER

REAR / ARRIÈRE



- // OE replacement compound for bikes with sintered pads
- // Designed for modern high performance, sport and big touring bikes
- // Sintered compound offering predictable and controllable performance for rear wheel use
- // Exclusive rear wheel compound formulated according to OEM concept offering ideal front/rear brake balance, to avoid over-braking and rear wheel lock-up



- // Composé de rechange pour motos équipées d'origine de plaquettes frittées
- // Conçu pour les motos modernes hautes performances, sportives et routières
- // Un composé fritté destiné aux roues arrière offrant des performances prévisibles et contrôlables
- // Composé exclusif pour les roues arrière, formulé selon le concept OEM et offrant un équilibre de freinage avant/arrière optimal pour éviter un freinage excessif et le blocage de la roue arrière.

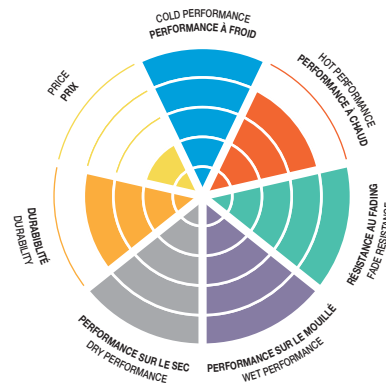

Les diagrammes de performances de freinage ne doivent être comparés individuellement que dans le domaine des composants STREET.





## UPGRADE / STANDARD



### SP - EVO SINTER

FRONT / AVANT



- // OE replacement and upgrade compound for modern cruisers, sport, adventure & touring bikes
- // State-of-the-art conductive sintered EVO compound formulated for strong initial bite to give instant brake feel, easy modulation and powerful in-stop performance
- // Fade free, consistent and reliable performance under extreme riding conditions and throughout brake pad lifetime
- // High thermal stability in combination with long pad lifetime and very low brake disc wear
- // Exceeds HH friction rating
- // NUCAP NRS technology secures a mechanical and indestructible bonding of the compound – first time ever used on a sinter compound pad
- // Front (SP) and rear (LS) compounds for ideal brake balance, to avoid rear wheel lock-up



- // Composé de rechange Haute performance pour les motos modernes Touring, les roadsters, les motos sportives et routières hautes performances
- // Composé EVO fritté conducteur à la pointe de la technologie, formulé pour offrir un freinage instantané et puissant, et une modulation facile.
- // Des performances fiables, uniformes et exemptes de fading même dans des conditions de conduite extrêmes et durant toute la durée de vie des plaquettes de frein
- // Stabilité thermique élevée associée à une longue durée de vie des plaquettes et une très faible usure des disques de frein
- // La technologie NUCAP NRS assure une liaison mécanique indestructible du composé
- // Composés avant (SP) et arrière (LS) offrant un équilibre de freinage parfait pour supprimer le risque de blocage de la roue arrière

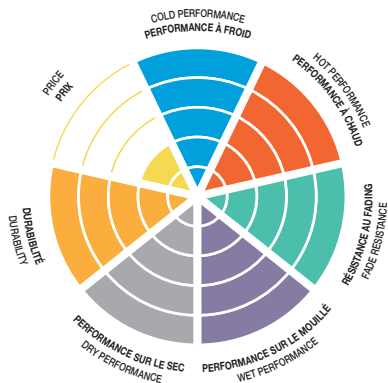

Brake performance diagrams to be compared individually within STREET compounds only.



### HF - CERAMIC

FRONT / AVANT • REAR / ARRIÈRE



- // OE replacement compound for bikes with non-sintered pads
- // Designed for commuters, general-purpose street and cruiser bikes
- // Ceramic compound offers long pad life, low dust and low brake rotor wear
- // Excellent, consistent performance in wet and dry conditions
- // NUCAP NRS technology secures a mechanical and indestructible bonding of the compound
- // Innovative noise-reduction technology for high comfort and low development of noise



- // Composé de rechange pour motos équipées d'origine de plaquettes non frittées
- // Conçu pour les motos effectuant des trajets quotidiens, les motos routières polyvalentes et celles destinées aux longs périples
- // Composé céramique offrant une longue durée de vie, peu de poussière et une faible usure du disque de frein/rotor
- // Excellentes performances uniformes dans toutes les conditions, sèches ou humides
- // La technologie NUCAP NRS assure une liaison mécanique indestructible du composé
- // Technologie innovante de réduction du bruit pour un confort supérieur et une faible propagation du bruit

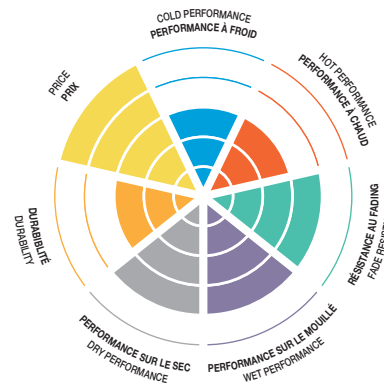

Les diagrammes de performances de freinage ne doivent être comparés individuellement que dans le domaine des composants STREET.









## LICENSE TO FREEDOM



If you have a passion for the American lifestyle, and the unique design and characteristics of the famous American motorcycle brands such as Harley Davidson, Victory and Indian, then SBS has the answer to your brake needs.

Our range of brake pads developed especially for American made motorcycles features compounds that unite high power with low noise and long lifetime. Our range has full coverage - vintage models back from the 70s as well as brand new American built bikes.

Choose between:

- // HIGH PERFORMANCE & NO DUST – H.HS / H.LS
- // HIGH POWER & NOISE REDUCTION FORMULA – H.CT
- // ULTRA QUIET & LOW DUST – H.HF

Follow our recommendations for the ideal pads for your bike.



Si vous êtes passionné par le style de vie américain et par le design et les caractéristiques uniques des célèbres marques de motos américaines comme Harley Davidson, Buell et Indian, alors SBS a la solution qu'il vous faut en matière de freinage.

Notre gamme de plaquettes de frein spécialement conçue pour les motos américaines utilise des composés associant puissance élevée, bruit réduit et durée de vie prolongée. Notre gamme offre une couverture complète : des modèles vintage des années 80 aux toutes dernières motos des marques américaines.

Choisissez entre les versions :

- // HIGH PERFORMANCE & NO DUST – H.HS / H.LS
- // HIGH POWER & NOISE REDUCTION FORMULA – H.CT
- // ULTRA QUIET & LOW DUST – H.HF

Suivez nos recommandations pour trouver les plaquettes idéales pour votre moto.



GO AHEAD





# HIGH PERFORMANCE & NO DUST



## H.HS - SINTER

FRONT / AVANT



- // OE replacement HH rated compound for bikes with sintered pads
- // Designed for modern high performance, sport and big touring bikes
- // Sintered compound formulated for low wear, high thermal stability and excellent brake feel
- // Class-leading, high performance, developed in racing and fine-tuned for street use
- // Excellent for stainless steel or cast iron brake rotors and keeps your whitewalls clean
- // Front (H.HS) and rear (H.LS) compounds for ideal brake balance, to avoid rear wheel lock-up



- // Composé de rechange Haute Performance pour motos équipées d'origine de plaquettes frittées
- // Conçu pour les motos modernes hautes performances, sportives et routières
- // Composé fritté formulé pour une faible usure, une stabilité thermique élevée et une excellente sensation de freinage
- // Composé aux performances supérieures exceptionnelles, développé pour la compétition et la route
- // Idéalement adapté aux disques de frein en acier inoxydable ou en fonte
- // Composés avant (H.HS) et arrière (H.LS) offrant un équilibre de freinage parfait pour supprimer le risque de blocage de la roue arrière

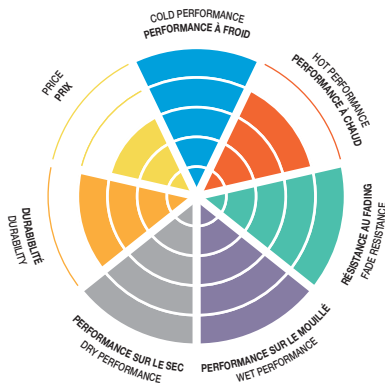

Brake performance diagrams to be compared individually within AMERICAN compounds only.



## H.LS - SINTER

REAR / ARRIÈRE



- // OE replacement compound for bikes with sintered pads
- // Designed for modern high performance, sport and big touring bikes
- // Sintered compound offering predictable and controllable performance for rear wheel use
- // Exclusive rear-wheel compound formulated according to OEM concept, to offer ideal front/rear brake balance, to avoid over-braking and rear wheel lock-up



- // Composé de rechange pour motos équipées d'origine de plaquettes frittées
- // Conçu pour les motos modernes hautes performances, sportives et routières
- // Un composé fritté destiné aux roues arrière offrant des performances prévisibles et contrôlables
- // Composé exclusif pour les roues arrière, formulé selon le concept OEM et offrant un équilibre de freinage avant/arrière optimal pour éviter un freinage excessif et le blocage de la roue arrière

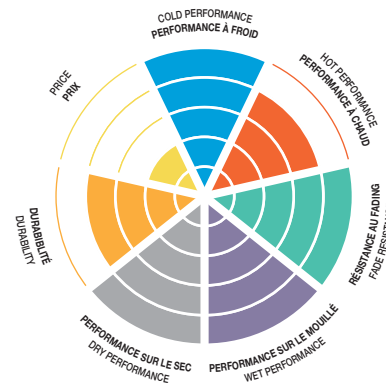

Les diagrammes de performances de freinage ne doivent être comparés individuellement que dans le domaine des composants AMERICAN.





AMERICAN BRAKE PADS



# HIGH POWER & NOISE REDUCTION FORMULA / ULTRA QUIET & LOW DUST



## H. CT - CARBON

FRONT / AVANT • REAR / ARRIÈRE



- // Performance upgrade compound, excellent for bikes with customized brake system and rotors
- // Compatible with stainless steel, cast iron, chromed and polished brake rotors
- // HH-rated performance, developed in racing and fine-tuned for street use
- // Unmatched feel and control at brake lever in wet and dry conditions
- // NUCAP NRS technology secures a mechanical and indestructible bonding of the compound



- // Composé Haute Performance, idéal pour les motos dotées de disques et de systèmes de frein personnalisés
- // Compatible avec les disques de frein en acier inoxydable, en fonte, chromés et polis
- // Composé aux performances de classe HH, conçu pour la compétition et adapté à la conduite routière
- // Des sensations et un contrôle inégalés au niveau du levier de frein dans toutes les conditions, sèches ou humides
- // La technologie NUCAP NRS assure une liaison mécanique indestructible du composé

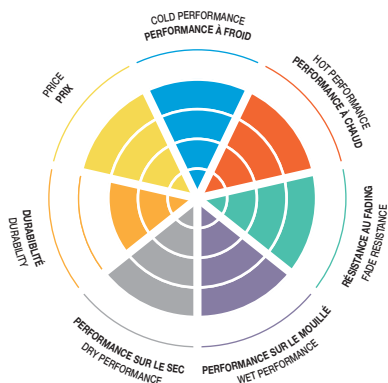

Brake performance diagrams to be compared individually within AMERICAN compounds only.



## H. HF - CERAMIC

FRONT / AVANT • REAR / ARRIÈRE



- // OE replacement compound for bikes with non-sintered pads
- // Designed for commuters, general-purpose street and cruiser bikes
- // Ceramic compound offers long pad life, low dust and low brake disc/rotor wear
- // Excellent, consistent performance in wet and dry conditions
- // NUCAP NRS technology secures a mechanical and indestructible bonding of the compound
- // Innovative noise-reduction technology for high comfort and low development of noise



- // Composé de rechange pour motos équipées d'origine de plaquettes non frittées
- // Conçu pour les motos effectuant des trajets quotidiens, les motos routières polyvalentes et celles destinées aux longs périples
- // Composé céramique offrant une longue durée de vie, peu de poussière et une faible usure du disque de frein/rotor
- // Excellentes performances uniformes dans toutes les conditions, sèches ou humides
- // La technologie NUCAP NRS assure une liaison mécanique indestructible du composé
- // Technologie innovante de réduction du bruit pour un confort supérieur et une faible propagation du bruit

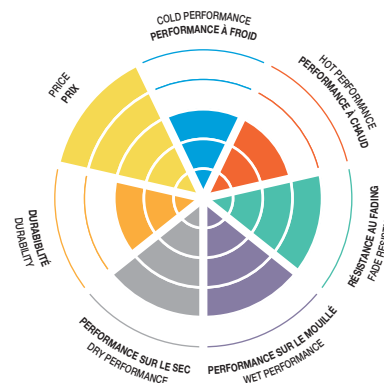

Les diagrammes de performances de freinage ne doivent être comparés individuellement que dans le domaine des composants AMERICAN.







# LICENSE TO FUN



When it comes to city traffic, a scooter is often the ideal vehicle. In the dense traffic you have to rely on your brakes. The SBS scooter brake pads offer the ideal brake performance and durability for this environment.

We offer different compounds for different kinds of scooters and riding needs. Our market coverage is wide with pads and compounds to fit small 50 cc models all the way to modern, high performance maxi scooters.

Choose between:

- // MAXI SINTER – MS
- // STANDARD & MAXI – CT
- // STANDARD & MAXI – HF

Follow our recommendations for the ideal pads for your scooter.



En ville, le scooter est souvent le véhicule idéal. Quand la circulation est dense, vous devez pouvoir compter sur vos freins. Les plaquettes de frein SBS Scooter offrent les performances de freinage et la longévité idéales pour cet environnement.

Nous proposons différents composés en fonction des différents types de scooters et de besoins. Notre gamme couvre tout le marché, allant des petits modèles 50 cm<sup>3</sup> jusqu'aux maxi scooters modernes hautes performances.

Choisissez entre les versions :

- // MAXI SINTER – MS
- // STANDARD & MAXI – CT
- // STANDARD & MAXI – HF

Suivez nos recommandations pour trouver les plaquettes idéales pour votre scooter.

**sbs**<sup>®</sup>  
GO AHEAD





# MAXI SINTER / STANDARD & MAXI



## MS - SINTER

FRONT / AVANT • REAR / ARRIÈRE



- // High performance upgrade sintered compound for Maxi scooters from 250 cc and up
- // Recommended for Maxi scooters equipped with motorcycle technology
- // State-of-the-art sintered compound formulated for low wear, high thermal stability and excellent brake feel



- // Composé fritté Haute performance destiné aux maxi scooters de 250 cm<sup>3</sup> et plus
- // Recommandé pour les maxi scooters équipés d'une technologie type moto
- // Composé fritté à la pointe de la technologie formulé pour une faible usure, une stabilité thermique élevée et une excellente sensation de freinage

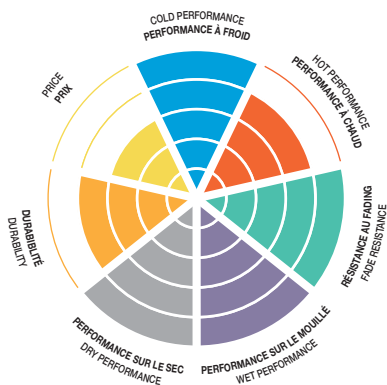

Brake performance diagrams to be compared individually within SCOOTER compounds only.



## CT - CARBON

FRONT / AVANT • REAR / ARRIÈRE



- // Performance upgrade carbon compound for medium size scooters 125-249 cc
- // Recommended for sporty riding, everyday transportation and fun
- // NUCAP NRS technology secures a mechanical and indestructible bonding of the compound



- // Composé carbone Haute Performance destiné aux scooters de taille moyenne (125 à 249 cm<sup>3</sup>).
- // Recommandé pour la conduite sportive, les trajets quotidiens et le plaisir
- // La technologie NUCAP NRS assure une liaison mécanique indestructible du composé

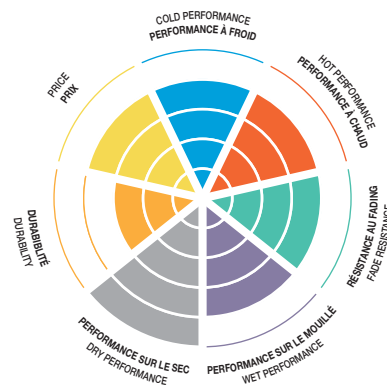

Les diagrammes de performances de freinage ne doivent être comparés individuellement que dans le domaine des composants SCOOTER.





# STANDARD & MAXI



## HF - CERAMIC

FRONT / AVANT • REAR / ARRIÈRE



- // OE replacement ceramic compound for small and medium size scooters 50-124 cc
- // Recommended for commuters and general-purpose street riding
- // NUCAP NRS technology secures a mechanical and indestructible bonding of the compound



- // Composé céramique de recharge destiné aux scooters de taille petite à moyenne (50-124 cm<sup>3</sup>)
- // Recommandé pour les trajets quotidiens
- // La technologie NUCAP NRS assure une liaison mécanique indestructible du composé

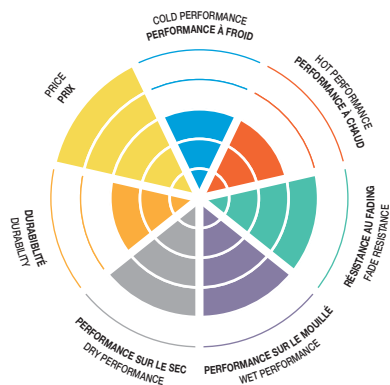

Brake performance diagrams to be compared individually within SCOOTER compounds only.

Les diagrammes de performances de freinage ne doivent être comparés individuellement que dans le domaine des composants SCOOTER.



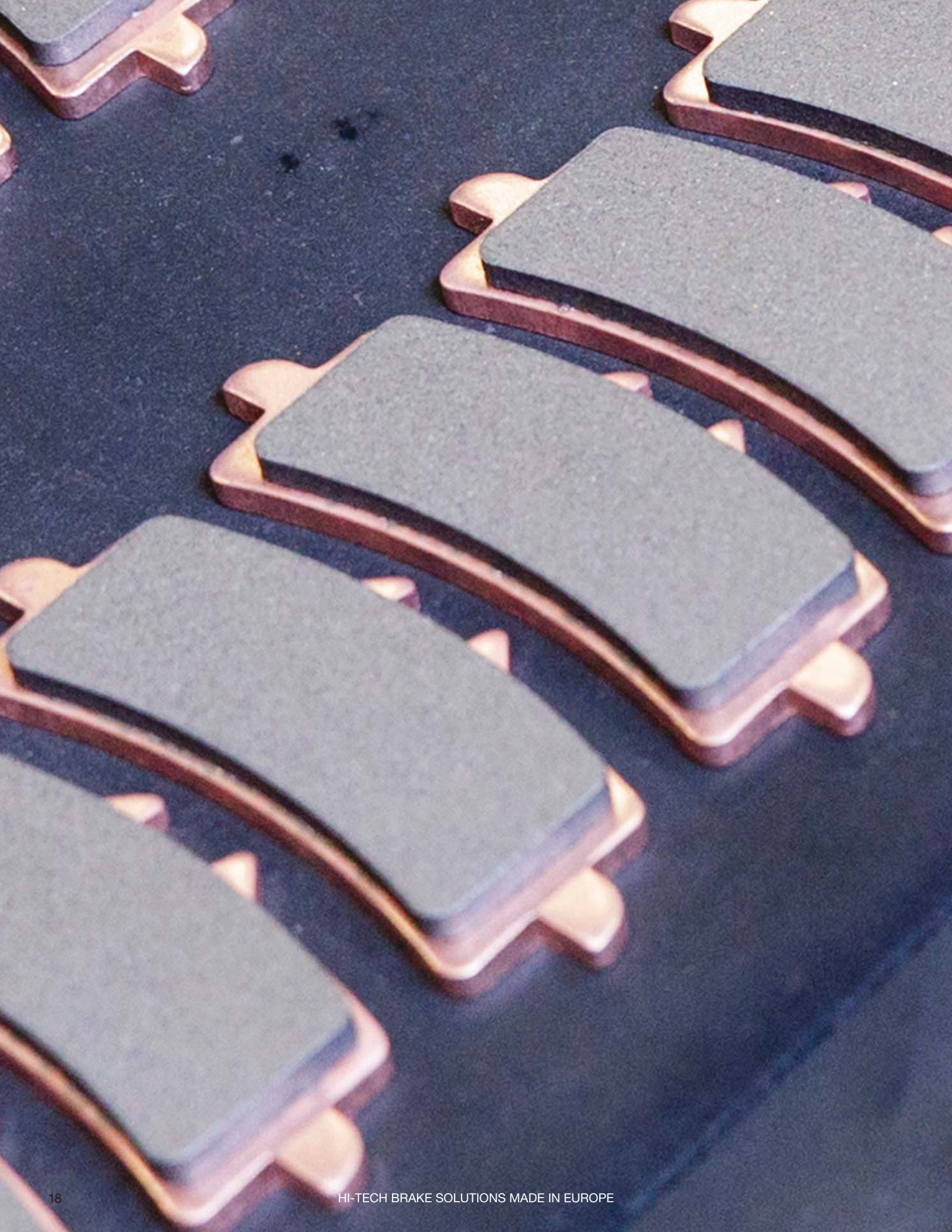



# LICENSE TO WIN



KENAN SOFUOGLU



For more than 25 years racing has been part of our DNA.

Through our Partners in Racing concept, we deliver the stopping power to the best of the best in racing. Whether it comes to international top level road racing such as World Superbike, Supersport, Endurance, The Isle of Man TT, National competitions, track days or classic road racing, SBS offers you the brake pads you need for gaining those important 100<sup>th</sup> of a second over the competition. Our race compounds are specially developed for competition and race track use – used by some of the World's best riders like Michael Dunlop, John McGuinness, Kenan Sofuoglu, Tom Luthi and the list goes on...

Choose between:

- // ROAD RACING & ENDURANCE – DS
- // ROAD RACING & CLASSIC RACING – DC / DCC
- // ROAD RACING & TRACK DAYS – RS
- // RACING REAR – RQ / LS

Follow our recommendations for the ideal pads for your bike.



Depuis plus de 25 ans, la course fait partie de notre ADN.

À travers notre concept « Partenaires de compétition », nous offrons LE top freinage aux meilleurs teams et pilotes. Qu'il s'agisse des courses sur circuits les plus prestigieuses comme le Mondial Superbike, Supersport ou Endurance, les compétitions nationales, les journées circuit ou les classiques routières, SBS vous propose les plaquettes de frein dont vous avez besoin pour gagner d'importants 100<sup>èmes</sup> de seconde au freinage. Nos composés de course sont spécialement conçus pour la compétition et les circuits. Ils sont testés et approuvés par les plus grands pilotes du Championnat du Monde.

Choisissez entre les versions :

- // ROAD RACING & ENDURANCE – DS
- // ROAD RACING & CLASSIC RACING – DC / DCC
- // ROAD RACING & TRACK DAYS – RS
- // RACING REAR – RQ / LS

Suivez nos recommandations pour trouver les plaquettes idéales pour votre moto.

**sbs**<sup>®</sup>

GO AHEAD





# ROAD RACING & ENDURANCE / ENDURANCE, CLASSIC RACING & ROAD RACING



## DS - DUAL SINTER

FRONT / AVANT - FOR RACE USE ONLY



- // The choice of numerous World Champions in Superbike, Supersport, Moto2 and Endurance
- // High-tech sintered compound available for racing & standard brake systems used in racing
- // High initial bite, linear and strong in-stop performance, consistent performance with excellent brake feel and control
- // Extremely long pad life makes DS perfect for Endurance racing
- // NUCAP NRS technology secures a mechanical and indestructible bond between the compound and backing plate
- // Laser cut backing plate to prevent deformation



- // Le choix de nombreux champions du monde en Superbike, Supersport, Moto2 et Endurance
- // Composé fritté haute technologie adapté aux systèmes de freinage de course et standard utilisés en compétition
- // Mordant élevé, performances de freinage impressionnantes et uniformes avec une excellente sensation de freinage et un contrôle inégalé
- // Excellente durée de vie des plaquettes pour les courses d'endurance.
- // La technologie NUCAP NRS assure une liaison mécanique indestructible du composé

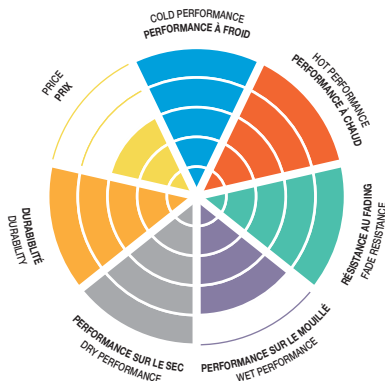

Brake performance diagrams to be compared individually within RACING compounds only.



## DC - DUAL CARBON

FRONT / AVANT - FOR RACE USE ONLY



- // The upgrade choice for Superbike, Supersport and Superstock racers in National Championship as well as for Track Day riders
- // High-tech carbon compound developed for racing and standard brake systems used for race and sport bikes
- // Low heat transfer rate protects brake system and brake fluid against extreme temperatures
- // Smooth initial bite, progressive in-stop performance with excellent brake lever feel and modulation
- // DEST technology used for pre-bedding of the compound to eliminate fade and secure consistent performance
- // NUCAP NRS technology secures a mechanical and indestructible bond between the compound and backing plate
- // Laser cut backing plate to prevent deformation



- // Le composé de choix pour les pilotes de Superbike, Supersport et Superstock des championnats nationaux mais aussi pour les journées sur circuit ("Track days")
- // Composé carbone haute technologie développé pour les systèmes de freinage de course et standard utilisés sur les motos de compétition et sportives
- // Le faible taux de transfert de chaleur protège le système de freinage et le liquide de frein contre les températures extrêmes
- // Mordant fluide, performances de freinage progressives avec une excellente sensation au niveau du levier de frein et une excellente modulation
- // Technologie DEST utilisée pour la pré-application du composé afin d'éliminer le fading et d'assurer des performances uniformes.
- // La technologie NUCAP NRS assure une liaison mécanique indestructible du composé

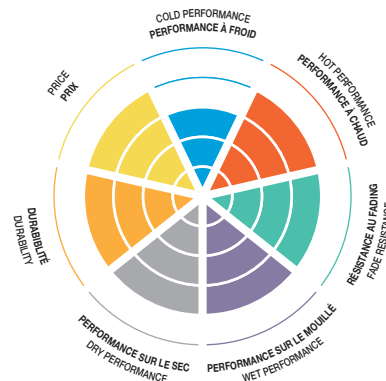

Les diagrammes de performances de freinage ne doivent être comparés individuellement que dans le domaine des composants RACING.





# ENDURANCE, CLASSIC RACING & ROAD RACING / ROAD RACING & TRACKDAYS



## DCC - DUAL CARBON

FRONT / AVANT - FOR RACE USE ONLY



- // The choice for classic road racing derived from more than 25 years of experience in World Championship racing and inspired by our championship winning DC Dual Carbon material
- // Smooth initial bite, ideal for classic front fork construction and tires. Progressive brake performance offering superior power and front-end feel
- // Thermal stability, suitable for single or dual disc set-up. Compatible with stainless steel and cast iron brake rotors
- // Low thermal conductivity reduces thermal load to seals, brake fluid and caliper parts
- // DEST technology used for pre-bedding of the compound to eliminate fade and secure consistent performance
- // NUCAP NRS technology secures a mechanical and indestructible bonding of the compound
- // Laser cut backing plate to prevent deformation



- // Le choix qui s'impose pour les courses classiques sur route s'appuie sur plus de 25 ans d'expérience en Championnat du monde, inspiré par notre matériau carbone gagnant DC Dual Carbon
- // Mordant fluide, idéal pour les fourches et les pneus avant classiques. Performances de freinage progressives offrant une puissance supérieure et une sensation avant-arrière optimale
- // Stabilité thermique, adaptée aux configurations à 1 et 2 disques. Compatible avec les disques de frein en acier inoxydable et en fonte
- // Faible conductivité thermique réduisant la charge thermique exercée sur les joints, le liquide de frein et les pièces des étriers
- // Technologie DEST utilisée pour la pré-application du composé afin d'éliminer le fading et d'assurer des performances uniformes.
- // La technologie NUCAP NRS assure une liaison mécanique indestructible du composé



Due to the unique nature of the DCC compound, formulated especially for vintage racing, it is not possible to compare to other products.



En raison de la nature unique du composé DCC, formulé spécialement pour les courses de motos vintage, toute comparaison avec d'autres produits est impossible.

Brake performance diagrams to be compared individually within RACING compounds only.



## RS - SINTER

FRONT / AVANT



- // The ideal and affordable choice for track days and club racing. Can be used for street riding
- // Sintered compound available for modern sportbike standard brake systems
- // Excellent for stainless steel or cast iron brake rotors
- // Strong initial bite, linear in-stop performance with good brake feel and control



- // Le choix économique idéal pour les journées sur pistes (track days) et les motos combinant pistes et routes
- // Composé fritté adapté aux systèmes de freinage standard des motos sportives et de course modernes
- // Idéalement adapté aux disques de frein en acier inoxydable ou en fonte
- // Mordant puissant, performances de freinage avec une bonne sensation de freinage et un contrôle maîtrisé

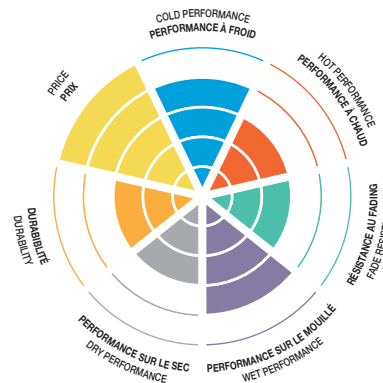

Les diagrammes de performances de freinage ne doivent être comparés individuellement que dans le domaine des composants RACING.





## ENDURANCE, CLASSIC RACING & ROAD RACING



### RQ - CARBON TECH

REAR / ARRIÈRE



- // Rear brake carbon compound with high brake performance
- // Excellent feel and control to use rear brake steering into turns and handle the bike out of turns



- // Composé carbone pour frein arrière offrant d'impressionnantes performances de freinage
- // Excellente sensation et contrôle aisé du frein arrière dans les virages, offrant une parfaite maîtrise de la moto en sortie de virage



### LS - SINTER

REAR / ARRIÈRE



- // Rear brake sintered compound with medium brake performance and long pad life
- // Recommended for riders using the rear brake occasionally or only slightly entering the turns



- // Composé fritté pour frein arrière offrant des performances de freinage intermédiaires et une longue durée de vie de plaquettes.
- // Recommandé pour les motards utilisant occasionnellement le frein arrière ou légèrement à l'entrée des virages.



# LICENSE TO ACTION



Enjoying the freedom in the desert. Conquering rocks and mountains. Racing down the dirt track for podium positions.

When riding off road is your passion, SBS offers you the ideal brake compound for the aggressive environment of sand, dust, mud and water. Whether on motorcycle, ATV or UTV.

Choose between our racing pads for competition at all levels or the alternatives when riding off road for leisure and fun. Our range covers all off road makes and models and of course for both front and rear applications.

Choose between:  
// RACING – RSI  
// CLUB, TRAILS & LEISURE – SI / CS / ATS

Follow our recommendations for the ideal pads for your bike.



Apprécier la liberté dans le désert. Conquérir les collines et les montagnes. Avaler les kilomètres de pistes poussiéreuses jusqu'au podium.

Si la conduite hors des sentiers battus est votre passion, SBS propose un composé de frein idéal pour les environnements agressifs mêlant sable, poussière, boue et eau. Que ce soit pour les motos, les quads ou autres VU Tout Terrain.

Choisissez parmi nos plaquettes spéciales course pour la compétition à tous les niveaux ou d'autres versions adaptées à la conduite tout terrain pour les loisirs et le plaisir. Notre gamme couvre toutes les marques et tous les modèles tout terrain, à la fois pour les applications avant et arrière.

Choisissez entre les versions :  
// RACING – RSI  
// CLUB, TRAILS & LEISURE – SI / CS / ATS

Suivez nos recommandations pour trouver les plaquettes idéales pour votre moto.

**sbs**  
GO AHEAD





## RACING / CLUB, TRAILS & LEISURE

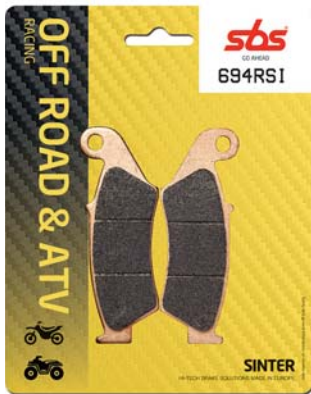

### RSI - SINTER

FRONT / AVANT • REAR / ARRIÈRE



- // Performance upgrade choice of MX GP World Championship MX GP and MX2 teams and riders
- // Sintered compound formulated for high thermal stability, powerful and predictable fade-free performance
- // Compatible with OE standard brake rotors and specially designed racing rotors



- // Le choix Haute Performance des teams et des pilotes du Championnat du monde MX GP et MX2
- // Composé fritté formulé pour une stabilité thermique élevée, une puissance supérieure et des performances prévisibles sans fading
- // Compatible avec les disques de frein OE standard et les disques spécialement conçus pour la course.

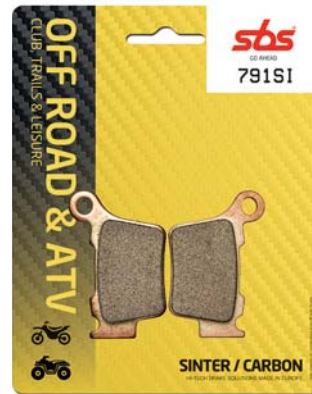

### SI - SINTER

FRONT / AVANT • REAR / ARRIÈRE



- // The upgrade choice for muddy, wet or sandy conditions
- // Sintered compound formulated for extended service intervals, high performance and easy modulation
- // Class-leading smooth performance developed in racing under severe conditions



- // Le choix idéal pour la boue, les terrains humides et le sable
- // Composant fritté formulé pour des intervalles d'entretien prolongés, des performances élevées et une modulation facile
- // Composé aux performances d'une fluidité inégalée, conçu pour la compétition dans les conditions les plus difficiles



Brake performance diagrams to be compared individually within OFF ROAD compounds only.

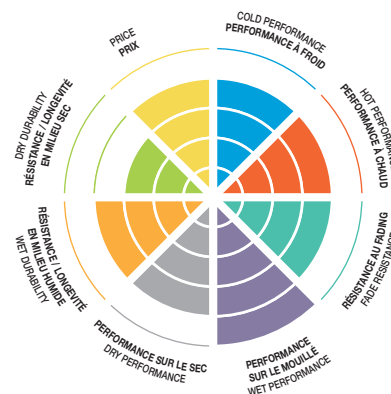

Les diagrammes de performances de freinage ne doivent être comparés individuellement que dans le domaine des composants OFF ROAD.





OFF ROAD & ATV BRAKE PADS

## CLUB, TRAILS & LEISURE

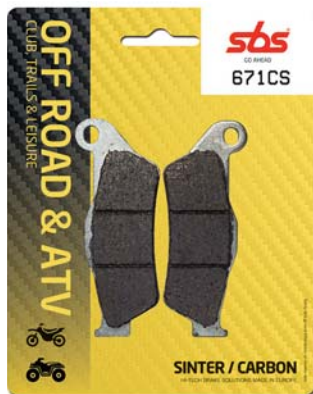

### CS - CARBON

FRONT / AVANT • REAR / ARRIÈRE



- // Affordable replacement choice for hobby motocross and competition
- // Carbon compound offers smooth, quiet and non-grabbing performance
- // NUCAP NRS technology secures a mechanical and indestructible bond between the compound and backing plate



- // Composé de rechange abordable, idéal pour le motocross de loisir et de compétition
- // Composé carbone offrant des performances fluides, silencieuses et sans broutage
- // La technologie NUCAP NRS assure une liaison mécanique indestructible du composé

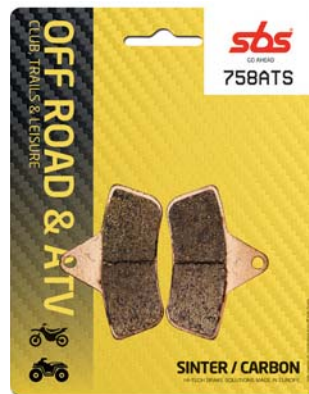

### ATS - SINTER

FRONT / AVANT • REAR / ARRIÈRE



- // OE replacement compound for combination with plain steel brake rotors
- // Sintered compound compatible with OE standard plain steel brake rotors as used with older Arctic Cat & Polaris ATV models



- // Composé de rechange à associer à des disques de frein en acier
- // Composé fritté compatible avec les disques de frein en acier standard d'origine comme ceux utilisés sur les anciens modèles de quads Arctic Cat et Polaris

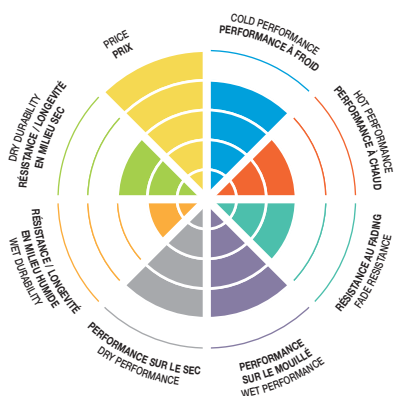

Brake performance diagrams to be compared individually within OFF ROAD compounds only.



ATS is a performance upgrade to be used with plain steel rotors on certain Polaris and Arctic Cat models, so its special formula cannot be compared to other compounds.



Les composés ATS sont des produits hautes performances destinés à être utilisés avec les disques de frein en acier ordinaire de certains modèles Polaris et Arctic Cat. Leur formulation spéciale ne permet pas de les comparer à d'autres composés.

Les diagrammes de performances de freinage ne doivent être comparés individuellement que dans le domaine des composants OFF ROAD.



## BRAKE SHOES WITH SPRINGS

## MÂCHOIRES DE FREIN À RESSORTS



Asbestos-free brake lining for superior performance and durability under all weather conditions. High grade alloy for superior strength. Surface treated against corrosion. Brake shoe springs made of high quality spring wire steel according to DIN 17223 specifications for max. flexibility.



Garniture de frein sans amiante pour des performances et une longévité supérieures quelles que soient les conditions météo. Alliage haute qualité pour une résistance supérieure. Surface traitée contre la corrosion. Ressorts de mâchoires de frein fabriqués en fil d'acier conforme à la norme DIN 17223 pour une flexibilité maximale.





**BRAKE PINS**

## STAINLESS BRAKE PINS

## AXES DE FREIN INOXYDABLES

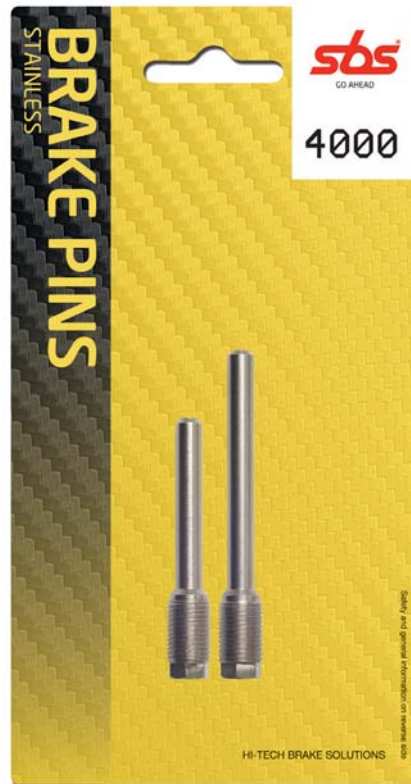

The SBS stainless brake pin range covers the most common MX and Enduro bikes from the early 1990s until today.

The range comprises 5 complete sets, front and rear together, but are also available as single packs with only front or rear to the respective model. Brake pad pins get wear grooves after a while so it is recommended to replace them regularly in order to prevent stiction and poor performance.

- // Made of high quality stainless steel 304
- // 8 mm hex head for quick and easy change of brake pad (excl. ref 4003)
- // Corrosion resistant
- // Smooth sliding between pin and brake pads



La gamme d'axes de frein inoxydables SBS est adaptée aux motos MX et Enduro les plus courantes du début des années 1990 à aujourd'hui.

Cette gamme comprend 5 jeux complets, avant et arrière, également disponibles en packs unitaires contenant uniquement un axe avant ou arrière du modèle souhaité. Comme les axes des plaquettes de frein développent des rainures d'usure après un certain temps, il est recommandé de les remplacer régulièrement afin d'éviter le frottement au démarrage et de faibles performances.

- // Acier inoxydable de haute qualité "304"
- // Tête hexagonale de 8 mm pour un changement rapide et facile des plaquettes de frein (sauf réf. 4003)
- // Résistance à la corrosion
- // Glissement fluide des axes contre les plaquettes de freins



## ACCESSORIES

## ACCESSOIRES



### BRAKE SYSTEM BLEEDER

Motorcycle brake system bleeder which allows quick, safe and clean exchange of brake fluid. Access to min. 6 bar air pressure is necessary. The bleeder is made of the best and most durable brake fluid resistant materials which means that it handles the highly corrosive brake fluid in a closed circuit. A special safety and "tip-over" valve, prevents the fluid to leak out when the container is full.

- // Built-in "tip-over" valve
- // Turnable line fitting
- // Additional 2-nipple line included
- // Manual in 12 languages

Part number 3908  
EPDM rubber units  
Art. number 3916.10 (10 pcs.)



### PURGEUR DE FREIN

Purgeur de système de freinage de moto permettant une vidange rapide, propre et sûre du liquide de frein. Nécessite de l'air comprimé à 6 bars minimum. Le purgeur est fabriqué avec les matériaux les plus durables résistant au liquide de frein, car il doit pouvoir supporter le liquide de frein hautement corrosif du circuit fermé. Une valve de sécurité spéciale « anti-refoulement » empêche le liquide de se vaporiser lorsque le réservoir est plein.

- // Valve « anti-refoulement » intégrée
- // Sens de fixation réversible
- // Fourni avec 2 embouts supplémentaires
- // Manuel disponible dans 12 langues

Réf. 3908  
Embouts en caoutchouc EPDM  
Réf. 3916.10 (10 pièces)



### ANTI-NOISE SHIMS

- // Vibration/noise resistant
- // Temperature transfer resistant
- // Piston protective
- // Do not use for racing

Part number 9500



### SHIMS POUR PLAQUETTES DE FREIN

- // Résistants aux vibrations/bruit
- // Résistants au transfert de température
- // Protection du piston
- // Ne pas utiliser pour la course

Part number 9500





MERCHANDISE

**sbs**  
GO AHEAD

**MERCHANDISE**

**PRODUITS DÉRIVÉS**



T-SHIRT VINTAGE

Art. no.	Size
982711	M
982712	L
982713	XL
982714	XXL



JACKET - DOWN&FEATHER

Art. no.	Size
984111	M
984112	L
984113	XL



T-SHIRT

Art. no.	Size
991411	M
991412	L
991413	XL
991414	XXL
991415	XXXL
991416	XXXXL



POLO-SHIRT

Art. no.	Size
996911	M
996912	L
996913	XL



BEANIE – 10 pcs

Art. no.	Size
991811	M
991812	L



SOCKS

Art. no.	Size
980101	39-42
980102	43-45



GO AHEAD CAP

Art. no.
9808



CAP

Art. no.
9995



GLOVES

Art. no.	Size
981211	M
981212	L
981213	XL

**MERCHANDISE**

**PRODUITS DÉRIVÉS**



**NON-WOWEN GO AHEAD BAG – 100 pcs**

Art. no.  
9803



**NON WOWEN BAG  
– 100 pcs**

Art. no.  
9959



**SBS PAPER GIFT BAG**

Art. no.  
9802

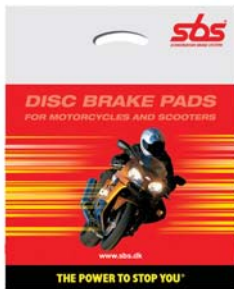

**PLASTIC BAG – 500 pcs  
45 x 35 cm**

Art. no.  
9930



**FLUID CAP – 10 pcs**

Art. no.  
9800



**COFFEE MUG**

Art. no.  
9974



**MUESLIBARS**

Art. no.  
9805



**BRAKE PAD MINTS  
– 20 pcs**

Art. no.  
9806



**SWEETS – 5 kg.**

Art. no.  
9842



**EARPLUGS**

Art. no.  
9815



**UMBRELLA – ø100 cm**

Art. no.  
983510





MERCHANDISE

MERCHANDISE

PRODUITS DÉRIVÉS



PERSONAL NOTEBOOK

Art. no.  
9816



PENS – 50 pcs

Art. no.  
9804



POWERBANK – KEYHOLDER

Art. no.  
9807



PC MINI-MUS

Art. no.  
9922



KEYHANGER

Art. no.  
9942



SUNGLASSES

Art. no.	Colour
9828	RED
9831	BLUE



BANNER 8 X 0.8 M –  
4 LOGOS

Art. no.  
9825



BUNTING 10 M

Art. no.  
9826



FLAG

Art. no.  
9875

## SALES & POS MATERIAL

### DISPLAYS



SBS offers practical and robust sales displays for POS promotion of SBS products. Choose between:



SBS offre des présentoirs de vente pratiques et robustes pour la promotion des produits SBS. Choisissez entre les versions :



**DISPLAY FOR WALL OR DESK MOUNTING**  
Art. no. 9899

Wall mountings and instruction 6 screws with raw plugs 12 hooks, 20 ref. cards. Width 57.2 cm, height 86.5 cm.

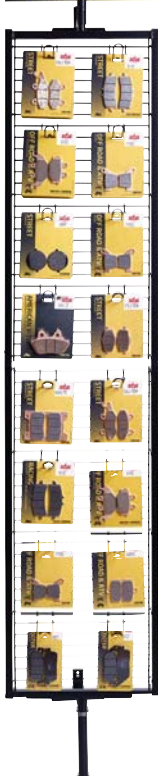

**10 HOOKS FOR DISPLAY RACK**  
Art. no. 9833



**10 REF. CARDS FOR DISPLAY RACK**  
Art. no. 9834

**DISPLAY FOR WALL MOUNTING**  
Art. no. 9832

Complete with: Wall mountings and instruction 6 screws with raw plugs 36 hooks, 40 ref. cards. Width 40 cm, depth 30 cm, height 229 cm.

## ARTICLES PROMOTIONNELS

### PRINT MATERIALS



Booklet:  
**MOTORCYCLE AND SCOOTER BRAKE PADS**  
English: Art. no. 99110101

Other languages on request.



Flyer:  
**STREET UPGRADE**  
English: Art. no. 997001

Other languages on request.



Flyer:  
**CLASSIC ROAD RACING**  
English: Art. no. 996801

Other languages on request.



Flyer:  
**BRAKE PINS STAINLESS**  
English: Art. no. 997101

Other languages on request.



# MOTORCYCLE SCOOTER OFF-ROAD ATV



**RECOMMENDED**1xx = Scooter Pads  
5xx = Street, Off Road & Racing Pads  
2xxx = Brake Shoes

ADLY					
	25 Silver Fox	00 - 05	111 HF	2028	
	50 Cat	01 - 08	111 HF		
	50 Cosy	01 - 08	111 HF		
	50 Fox	00 - 09	111 HF	2028	
	50 Fox Plus	01 - 09	111 HF		
	50 Jet	96 - 99	111 HF	2028	
	50 Panther	01 - 09	102 HF		
	50 Pista, Pista Twin Light	96 - 99	111 HF	2028	
	50 Silver Fox	00 - 05	111 HF	2028	
	50 Silver Fox	06 - 09	102 HF	2028	
	50 Super Sonic	00 - 05	102 HF*		
	50 Thunderbike	97 - 09	102 HF		
RS	50 Super Sonic	06 - 08	102 HF	102 HF	
RT	50 Road Tracer	02 - 06	111 HF		
	70 Fox Plus	01 - 05	111 HF		
	70 Pista, Pista Twin Light	01 - 05	111 HF		
	80 Cosy	01 - 06	111 HF		
RT	90 Road Tracer	02 - 06	111 HF		
	100 Cat	01 - 08	111 HF		
	100 Jet	96 - 99	111 HF	2028	
	100 Panther	01 - 06	102 HF		
	100 Silver Fox	01 - 05	111 HF		
	100 Silver Fox	06	102 HF	2028	
	100 Super Sonic	01 - 05	102 HF*		
	100 Thunderbike	01 - 04	102 HF*	102 HF	
RT	100 Road Tracer	02 - 06	111 HF		
	125 Cat	01 - 04	111 CT		
	125 Super Sonic	01 - 05	102 CT*		
	125 Thunderbike	01 - 04	102 CT*	102 CT	
	150 ATV	05 - 07	544 SI*	544 SI	
	150 Interceptor	05 - 07	544 SI*	544 SI	
	300 ATV	05 - 11	544 SI*	544 SI	
	300 Cross X Over	07 - 11	810 SI*		
	300 Cross X Road	07 - 11	810 SI*		
ATV	300 Sport	07 - 13	810 SI*	848 SI	
	320 S	07 - 13	810 SI*		
	320 U	07 - 13	810 SI*		

**APRILIA**

	50 Mini RX	04	803 RSI		
	50 Sport City One	08 - 12	177 HF		
RS-4	50	12 - 18	189 MS	101 HF	
RS-4	50 Replica	16 - 17	189 MS	101 HF	
SR	50 Ditech	01 - 06	123 HF	152 HF	
SR	50 Racing	00 - 04	123 HF	152 HF	
SR	50 Replica	94 - 96	117 HF	2012	
SR	50 Replica (Liquid Cooled)	96	123 HF	2012	
SR	50 Stealth, Racing	97 - 00	123 HF	123 HF	
SR	50 Street	05 - 12	123 HF	152 HF	
SR	50 WWW, Netscaper	97 - 99	149 HF	2012	
SX	50 Ltd.	07 - 15	197 CT	101 CT	
	125 Sportcity	04 - 12	108 CT	152 CT	
	125 Tuono ABS	17 - 18	821 HS	544 HF	
RS-4	125 (AJP cal.)	11 - 18	821 HS	585 HF	
RS-4	125 (J.Juan cal.)	11 - 18	566 HS	544 HF	
RS-4	125 Replica, ABS	16 - 18	821 HS	544 HF	
SR	125	99 - 03	153 CT	2205	
SR	125 Max	12 - 17	177 CT	177 CT	
SR	125 Sport City One	12	177 CT		
SX	125	08 - 13	671 HF	651 HF	
SR	150	00 - 03	153 CT	2205	
	200 Sportcity	04 - 08	108 CT	152 CT	
RS	250	97 - 02	706 HF*	519 HF	
RS	250 Pista	04	706 HF*	519 HF	
SR	300 Max	12 - 18	177 MS	177 MS	
MXV	450	09 - 13	694 RSI	790 RSI	
RXV	450	06 - 13	694 SI	790 SI	
SXV	450	06 - 13	842 RSI	790 RSI	

**RECOMMENDED**1xx = Scooter Pads  
5xx = Street, Off Road & Racing Pads  
2xxx = Brake Shoes

APRILIA					
SXV	450 Van den Bosch Rep.	08 - 10	695 RS	790 RSI	
RXV	550	06 - 13	694 SI	790 SI	
SXV	550	06 - 13	842 RSI	790 RSI	
SXV	550 Van den Bosch Rep.	08 - 10	695 RS	790 RSI	
	650 Pegaso	92 - 94	681 HF	651 HF	
	650 Pegaso	95 - 00	674 HS	692 HF	
	650 Pegaso Strada	05 - 09	706 HS	675 LS	
	750 Dorsoduro Factory	12 - 13	706 HS*	675 LS	
SL	750 Shiver GT, ABS	09 - 12	844 HS*	675 LS	
SL	750 Shiver, ABS	07 - 18	844 HS*	675 LS	
SMV	750 Dorsoduro	08	706 HS*	675 LS	
SMV	750 Dorsoduro	09 - 18	844 HS*	675 LS	
NA	850 Mana	07	844 HS*	675 LS	
NA	850 Mana GT, ABS	09 - 13	844 HS*	588 HF	
	850 Mana GT, ABS (Parking Brake)	09 - 13		879 HF	
NA	850 Mana, ABS	08 - 11	844 HS*	588 HF	
	1000 Blue Marlin	02	706 HS*	730 LS	
ETV	1000 Caponord	01 - 08	674 HS*	730 LS	
ETV	1000 Caponord Rally Raid	04 - 08	674 HS*	730 LS	
RST	1000 Futura	01 - 03	706 HS*	671 LS	
RSV	1000 Factory Pista	04	762 HS*	730 LS	
RSV	1000 Falco SL, R	00 - 04	706 HS*	730 LS	
RSV	1000 Mille	97 - 01	706 HS*	730 LS	
RSV	1000 Mille	02 - 03	762 HS*	730 LS	
RSV	1000 Mille Nera	04	762 HS*	730 LS	
RSV	1000 Mille R	00	706 HS*	730 LS	
RSV	1000 Mille R	01 - 07	762 HS*	730 LS	
RSV	1000 Mille R Factory	04 - 05	762 HS*	730 LS	
RSV	1000 Mille SP	00	706 HS*	730 LS	
RSV	1000 Tuono Fighter	03 - 05	706 HS*	730 LS	
RSV	1000 Tuono R	03	762 HS*	730 LS	
RSV	1000 Tuono R, ABS	04 - 12	706 HS*	730 LS	
RSV	1000 Tuono R Factory, ABS	06 - 12	762 HS*	730 LS	
RSV	1000 Tuono V4 R	11 - 13	706 HS*	730 LS	
RSV	1000 Tuono V4 R	14	900 HS*	730 LS	
RSV4	1000 , ABS	09 - 13	841 SP*	730 LS	
RSV4-R	1000 , ABS APRC	10	841 SP*	730 LS	
RSV4-RF	1000	15 - 18	901 SP*	730 LS	
RSV4-RR	1000	15 - 18	901 SP*	730 LS	
RSV	1100 Tuono V4	15	900 HS*	730 LS	
RSV	1100 Tuono V4 Factory	16 - 18	900 HS*	730 LS	
RSV	1100 Tuono V4 RR	15 - 18	900 HS*	730 LS	
	1200 Caponord	13 - 18	900 SP*	675 LS	
	1200 Caponord Rally	15 - 18	900 SP*	675 LS	
	1200 Caponord Travel Pack	16 - 18	900 SP*	675 LS	
	1200 Dorsoduro, ABS	11 - 14	706 HS*	675 LS	

**ARCTIC CAT**

	50 2WD	04 - 06	2048		
	50 DVX	06 - 08	2048	638 SI	
	90 2WD	02 - 04	2048		
	90 DVX	06 - 14	2048	638 SI	
	250 2x4	05 - 06	822 ATS*	822 ATS	
	250 2x4 (Man. Hand Brake)	99 - 04		827 ATS	
	250 2x4/4x4	99 - 04	758 ATS*	758 ATS	
	250 4x4 (Man. Hand Brake)	00 - 04		827 ATS	
	250 DVX	06 - 09	810 SI*	775 SI	
	300 2x4	10 - 13	822 ATS*	822 ATS	
	300 2x4 (Man. Hand Brake)	98 - 04		827 ATS	
	300 2x4/4x4	98 - 04	758 ATS*	758 ATS	
	300 4x4	05	822 ATS*	822 ATS	
	300 4x4 (Man. Hand Brake)	98 - 05		827 ATS	
	300 DVX	09 - 16	810 SI*	775 SI	
	375 2x4/4x4	02	758 ATS*	758 ATS	
	375 2x4/4x4 (Man. Hand Brake)	02		827 ATS	
	400 2x4 (Man. Hand Brake)	98 - 02		827 ATS	

\* = 2 sets required / 2 jeux pour l'Avant.





**RECOMMENDED**

1xx = Scooter Pads  
5xx = Street, Off Road & Racing Pads  
2xxx = Brake Shoes



ARCTIC CAT					
400	2x4/4x4	98 - 04	758 ATS*	758 ATS	
400	2x4/4x4 (FIS)	02 - 04	758 ATS*	758 ATS	
400	2x4/4x4 (FIS)	05 - 07	822 ATS*	822 ATS	
400	2x4/4x4 (FIS) Aut. (Man. Hand Brake)	03 - 04		827 ATS	
400	2x4/4x4 (FIS) (Man. Hand Brake)	02 - 04		827 ATS	
400	2x4/4x4 (FIS) (Man. Hand Brake)	05 - 08		758 ATS	
400	4x4 (Man. Hand Brake)	98 - 04		827 ATS	
400	DVX	04 - 08	592 SI*	649 SI	
400	TBX 4x4	04	758 ATS*	758 ATS	
400	TBX 4x4 (Man. Hand Brake)	04		827 ATS	
TRV	400	09 - 13	822 ATS*	822 ATS	
	440 Bear Cat	96 - 97		758 ATS	
	450 H1	10	822 ATS*	822 ATS	
XC	450	11 - 14	822 ATS*	822 ATS	
	454 Arctic Cat 4x4	98	758 ATS*	758 ATS	
	454 Bear Cat 2x4/4x4 (Man. Hand Brake)	96 - 98 98	758 ATS*	758 ATS 827 ATS	
	500 2x4 (FIS) (Man. Hand Brake)	02		827 ATS	
	500 2x4 (Man. Hand Brake)	02		827 ATS	
	500 2x4/4x4	98 - 04	758 ATS*	758 ATS	
	500 2x4/4x4 (FIS)	02 - 04	758 ATS*	758 ATS	
	500 2x4/4x4 (FIS)	05 - 09	822 ATS*	822 ATS	
	500 4x4 (FIS) Aut. (Man. Hand Brake)	02 - 03		827 ATS	
	500 4x4 (FIS) (Man. Hand Brake)	02 - 03		827 ATS	
	500 4x4 (Man. Hand Brake)	98 - 02		827 ATS	
	500 TBX 4x4	02 - 04	758 ATS*	758 ATS	
	500 TBX 4x4	05 - 06	822 ATS*	822 ATS	
	500 TBX 4x4 (Man. Hand Brake)	03 - 04		827 ATS	
	500 TBX 4x4 Aut. (Man. Hand Brake)	02		827 ATS	
	500 TRV 4x4	03 - 04	758 ATS*	758 ATS	
	500 TRV 4x4	05 - 06	822 ATS*	822 ATS	
	500 TRV 4x4 (Man. Hand Brake)	03 - 04		827 ATS	
	550 H1	09 - 13	822 ATS*	822 ATS	
	550 LTD	09 - 12	822 ATS*	822 ATS	
	550 Prowler	09 - 14	822 ATS*	822 ATS	
TRV	550	09 - 14	822 ATS*	822 ATS	
	650 H1 4x4 Aut.	05 - 11	822 ATS*	822 ATS	
	650 Prowler	06 - 08	822 ATS*	822 ATS	
	650 V2 4x4 Aut.	05 - 06	822 ATS*	822 ATS	
	650 V2 4x4 Aut. LE	05 - 06	822 ATS*	822 ATS	
	700 Diesel	06 - 14	822 ATS*	822 ATS	
	700 H1	09 - 10	822 ATS*	822 ATS	
	700 Prowler	08	822 ATS*	822 ATS	
	700 Wildcat Sport	15 - 18	946 ATS*	822 ATS	
	700 Wildcat Sport LTD.	16 - 18	946 ATS*	822 ATS	
	700 Wildcat Sport LTD. EPS	17 - 18	946 ATS*	822 ATS	
	700 Wildcat Sport XT	15 - 18	946 ATS*	822 ATS	
	700 Wildcat Sport XT EPS	16 - 18	946 ATS*	822 ATS	
TBX	700	12 - 14	822 ATS*	822 ATS	
TRV	700	09 - 12	822 ATS*	822 ATS	
	1000 Prowler	09	822 ATS*	822 ATS	
	1000 Thundercat	09 - 14	822 ATS*	822 ATS	
	1000 Wildcat 4X	16 - 18	912 ATS*	822 ATS	
	1000 Wildcat X	16 - 18	912 ATS*	822 ATS	
	1000 Wildcat X Ltd.	17 - 18	912 ATS*	822 ATS	
	1000 Wildcat X SE	17 - 18	912 ATS*	822 ATS	



**RECOMMENDED**

1xx = Scooter Pads  
5xx = Street, Off Road & Racing Pads  
2xxx = Brake Shoes



ARCTIC CAT					
TRV	1000	09 - 14	822 ATS*	822 ATS	
<b>ARMSTRONG</b>					
MX	500	86	519 SI		
MX	600	86	519 SI		
<b>ATK</b>					
	all models	94	611 SI	611 SI	
ATK	250 CC,MX	91 - 92	601 HF	519 SI*	
ATK	350 ES CC,MX,STD	91 - 92	601 HF	519 SI*	
ATK	350 GS	93	519 SI	519 SI*	
ATK	406 CC,MX	91 - 92	601 HF	519 SI	
ATK	560	84 - 85	519 SI	2122	
ATK	560	86	519 SI	532 HF	
ATK	560	87 - 88	519 SI	559 HF	
ATK	560	89 - 91	601 HF	607 HF	
ATK	604	91	601 HF	607 HF	
ATK	604 ES CC,MX,STD	91 - 92	601 HF	519 SI	
ATK	604 Quadracer	90	601 HF	607 HF	
ATK	640	93	519 SI	519 SI*	
<b>BENELLI</b>					
TNT	125	17	558 HF		
	350 Zenzero	12 - 15	163 CT	101 CT	
	500 Leoncino	16 - 17	706 HS*	730 LS	
TRK	502	16 - 17	706 HS*	730 LS	
BX	505 Enduro	08	671 SI	675 SI	
BN	600	12 - 13	706 HS*	730 LS	
BN	600	14 - 17	762 HS*	730 LS	
BN	600 GT	14 - 15	762 HS*	730 LS	
	654 Sport	83	519 HF*	519 HF	
	750 Sei	75 - 78	506 HF*		
	756 Cue	07 - 09	762 HS*	730 LS	
	756 Cue	10 - 12	706 HS*	730 LS	
	899 Trek	07 - 12	706 HS*	730 LS	
TnT	899	07 - 15	706 HS*	730 LS	
TnT	899 Century Racer	11	762 HS*	730 LS	
	900 Sei	81 - 83	554 HF*		
	900 Sei	84	506 HF*	506 HF	
	900 Tornado 3	00 - 06	706 HS*	519 LS	
	900 Tornado TRE	03 - 06	762 HS*	730 LS	
	900 Tornado TRE RS	04 - 06	762 HS*	730 LS	
TnT	1100	04	706 HS*	519 LS	
TnT	1130	05 - 14	706 HS*	730 LS	
TnT	1130 Cafe Racer	05 - 13	762 HS*	730 LS	
TnT	1130 Century Racer	11 - 12	762 HS*	730 LS	
TnT	1130 Officine	07	762 HS*	730 LS	
TnT	1130 R	17	841 HS*	730 LS	
TnT	1130 Sport	05 - 08	762 HS*	730 LS	
TnT	1130 Titanium	05 - 08	762 HS*	730 LS	
TnT	1130 Trek	06 - 12	706 SP*	730 LS	
TnT	1130 Trek Amazonas	07 - 15	706 SP*	730 LS	
<b>BETA</b>					
	50 AJP Caliper incl. pin/spring	90 - 18	188 HF		
	50 ProRace 12/10	04	803 RSI	803 RSI	
	50 Rev	00 - 09	559 HF	559 HF	
ST	50	97	559 HF	559 HF	
	80 EVO	09 - 10	802 RSI		
	80 EVO Junior	10 - 11	559 HF	559 HF	
	80 Rev	00 - 07	559 HF	559 HF	
	80 Rev	08 - 10	802 RSI	896 RSI	
	125 EVO	09 - 14	802 RSI	895 RSI	
	125 Rev 3	00 - 05	802 RSI	802 RSI	
	125 Rev 3	06 - 08	802 RSI	896 RSI	
ALP	125	90	595 HF	607 HF	
ALP	125	99 - 09	559 RSI	559 RSI	

\* = 2 sets required / 2 jeux pour l'Avant.

Full compound selection, see under "Brake pad 1:1 Drawings" / Sélection complète de composés, voir "1:1 Schémas Plaquettes de frein".  
For ABE type approvals, see page 1 / Pour les homologations de type ABE, voir page 2.

**RECOMMENDED**1xx = Scooter Pads  
5xx = Street, Off Road & Racing Pads  
2xxx = Brake Shoes

BETA					
ALP	125 4-stroke	00 - 05	559 RSI	559 RSI	
ALP	125 4-stroke	06 - 09	774 HF	861 HF	
RR	125	18 -	694 SI	790 SI	
SR	125 34	89	559 HF	636 HF	
TR	125 32,33	86 - 87	595 HF		
TR	125 34	88	595 HF	607 HF	
TR	125 34	92	672 HF	636 HF	
TR	125 34,35	89 - 90	559 RSI	559 RSI	
TR	125 36	92	672 HF	636 HF	
TRIAL	125	97	559 RSI	636 HF	
R	150	10 - 13	814 HF		
	200 EVO	09 - 14	802 RSI	895 RSI	
	200 Rev 3	06 - 08	802 RSI	896 RSI	
ALP	200 4-stroke	00 - 05	559 RSI	559 RSI	
ALP	200 4-stroke	06	774 HF	861 HF	
	240 Super Trial	92	559 RSI	636 HF	
ALP	240	92	559 RSI	636 HF	
ALP	240	96	559 RSI	519 RSI	
TR	240 33	86 - 88	595 HF		
	250 4-T Rev 3	07 - 11	802 RSI	896 RSI	
	250 EVO (2-T / 4-T)	09 - 14	802 RSI	895 RSI	
	250 Rev 3	00 - 04	802 RSI	802 RSI	
	250 Rev 3	05 - 09	802 RSI	896 RSI	
	250 Techno	96	559 RSI	559 RSI	
	250 Zero	91	559 RSI	636 HF	
ALP	250	92	559 RSI	636 HF	
ALP	250	97 - 03	559 RSI	559 RSI	
RR	250	05 - 09	694 SI	790 SI	
	260 Synt	92	595 HF	636 HF	
	260 Zero	91	559 RSI	636 HF	
ALP	260	96	559 RSI	519 RSI	
TR	260 34	86 - 88	595 HF	607 HF	
TR	260 34,35,ZERO	89 - 92	559 RSI	636 HF	
	270 Rev 3	00 - 04	802 RSI	802 RSI	
	270 Rev 3	05 - 08	802 RSI	896 RSI	
	290 EVO	09 - 13	802 RSI	895 RSI	
	300 Crosstrainer	15	694 SI	790 SI	
	300 EVO	09 - 15	802 RSI	895 RSI	
RR	300	13 - 18	694 SI	790 SI	
	350 4.0 Motard	04 - 06	566 RSI	574 RSI	
ALP	350 4.0	04 - 05	774 HF	574 RSI	
ALP	350 4.0	06	774 HF	861 HF	
RR	350 Efi	15	694 SI	790 SI	
RR	350 Efi Racing	15	694 SI	790 SI	
RR	350 Enduro	12 - 14	694 SI	790 SI	
RR	390	15 - 18	694 SI	790 SI	
RR	400 Enduro	05	694 SI	790 SI	
RR	430	15 - 18	694 SI	790 SI	
RR	430 Racing	15 - 18	694 SI	790 SI	
RR	450 Cross Country	12	694 SI	790 SI	
RR	450 Enduro	05 - 07	694 SI	790 SI	
RR	480	15 - 18	694 SI	790 SI	
RR	480 Racing	15 - 18	694 SI	790 SI	
RR	498 Enduro	12 - 14	694 SI	790 SI	
	500 GS, RV	84	519 HF		
RR	525 Enduro	05 - 13	694 SI	790 SI	
<b>BIMOTA</b>					
	all models	82 - 88	506 HF*	506 HF	
BBX	300 Enduro	12	694 SI	790 SI	
YB7	400	89	566 HF*	519 HF	
	500 Vdue	97 - 00	566 HF*	519 HF	
BBX	508 Enduro	12	694 SI	604 SI	
	600 Bellaria	91	566 HF*	519 HF	
YB9	600 SRI	97	566 HF*	519 HF	
BB1	650 Supermono	97 - 00	566 HF*	519 HF	
SB7	750	96 - 88	566 HF*	519 HF	
YB4	750	89	566 HF*	519 HF	

**RECOMMENDED**1xx = Scooter Pads  
5xx = Street, Off Road & Racing Pads  
2xxx = Brake Shoes

BIMOTA					
3D	800 Tesi	16	841 HS*	730 LS	
1D	851 Tesi	91	566 HF*	519 HF	
1D	900 Tesi	93	566 HF*	519 HF	
DB2	900	92 - 00	566 HF*	519 HF	
DB3	900 Mantra	97 - 00	566 HF*	519 HF	
DB4	900	99 - 00	706 HS*	519 LS	
1D	906 Tesi	91	566 HF*	519 HF	
	1000 Furano	92 - 93	566 HF*	519 HF	
2D	1000 Tesi	04 - 06	566 HS*	519 LS	
BB3	1000	14 - 18	901 SP*	730 LS	
DB5	1000 Mille	05 - 11	762 HS*	730 LS	
DB5	1000 S	07 - 11	762 HS*	730 LS	
DB6	1000 Delirio	07 - 09	762 HS*	730 LS	
SB3	1000 D	83	506 HF*	506 HF	
SB8	1000 R	98 - 00	706 HS*	519 LS	
SB8K	1000	06	706 HS*	519 LS	
SB8K	1000 Santamonica	07 - 09	762 HS*	519 LS	
YB11	1000	97 - 00	566 HF*	519 HF	
YB6	1000	89	566 HF*	519 HF	
YB8	1000	90	566 HF*	519 HF	
	1002 Dieci	91	566 HF*	519 HF	
DB10	1078 Bimotard	12	762 HS*	730 LS	
DB5	1078 RE	12	762 HS*	730 LS	
DB7	1098	08	762 HS*	730 LS	
DB7	1099	09	901 HS*	519 LS	
3D	1100 Tesi	07 - 11	762 HS*	730 LS	
DB6R	1100 Delirio	08 - 09	762 HS*	730 LS	
DBX	1100	13 - 18	674 HS*	671 LS	
SB6	1100	97 - 00	566 HF*	519 HF	
DB8	1198	10 - 14	901 SP*	730 LS	
	1200 Impeto	16 - 17	841 HS*	730 LS	
DB11	1200 VLX	13	901 HS*	730 LS	
DB12	1200	12	762 HS*	730 LS	
DB9	1200 Brivido	12 - 18	762 HS*	730 LS	
<b>BMW</b>					
	125 C1	00 - 03	176 CT	175 CT	
	200 C1	02 - 04	176 CT	175 CT	
G	310 GS	17 - 18	877 HS	675 LS	
G	310 R	16 - 18	877 HS	675 LS	
C	400 X	18 -	231 MS*	175 MS	
G	450 SMR	09 - 10	762 RS	791 RSI	
G	450 X	08 - 10	671 SI	791 SI	
R45	450	78 - 80	527 HF*	2139	
R45	450	80 - 85	527 HF*	2140	
C	600 Evolution	12 - 18	183 MS*	183 MS	
C	600 Evolution				
	(Parking Brake)	12 - 18		209 HF	
C	600 Sport	12 - 15	183 MS*	183 MS	
C	600 Sport (Parking Brake)	12 - 15		209 HF	
R60	600 Series	74 - 80		2139	
R60/7	600	76 - 77	520 HF	2139	
C	650 GT	12 - 18	183 MS*	183 MS	
C	650 GT (Parking Brake)	12 - 15		209 HF	
C	650 Sport	16 - 18	183 MS*	183 MS	
F	650 , ST	94 - 00	674 HF	675 HF	
F	650 CS Scarver	02 - 06	674 HS	675 LS	
F	650 GS	08 - 12	674 HS	675 LS	
F	650 GS ABS	01 - 07	674 HF	675 HF	
F	650 GS ABS	08 - 12	674 HS	675 LS	
F	650 GS Dakar	01 - 07	674 HF	675 HF	
F	650 GS, Rallye	01 - 07	674 HF	675 HF	
F	650 ST Strada	97 - 01	674 HF	675 HF	
G	650 GS	09 - 15	674 HS	675 LS	
G	650 GS Sertao	12 - 14	674 HS	675 LS	
G	650 Xchallenge	06 - 07	674 HS	675 LS	
G	650 Xcountry	06 - 09	674 HS	675 LS	
G	650 Xmoto	06 - 07	706 HS	675 LS	

\* = 2 sets required / 2 jeux pour l'Avant.





**RECOMMENDED**

1xx = Scooter Pads  
5xx = Street, Off Road & Racing Pads  
2xxx = Brake Shoes



Model	Year	Front	Rear
BMW R65	650	78 - 80	527 HF 2139
BMW R65	650	80	2140
BMW R65	650 GS	87 - 92	506 HF 2140
BMW R65	650 GS	91 - 92	506 HS
BMW R65	650 LS	82 - 85	506 HF* 2141
BMW R65/1	650	86	554 HF* 506 HF
BMW F	700 GS	13 - 16	674 HS* 675 LS
BMW R70	700 Series	74 - 80	2139
BMW F	750 GS	18 -	674 HS* 675 LS
BMW K75	750	90	640 HS 506 LS
BMW K75	750 C	85 - 88	506 HF* 2140
BMW K75	750 RT	91 - 96	640 HS* 506 LS
BMW K75	750 S, C	85 - 95	506 HF* 506 HF
BMW R75	750	86	2140
BMW R75/6	750	74 - 76	520 HF 2139
BMW R75/7	750	76 - 77	520 HF 2139
BMW	800 Touring	87	2140
BMW F	800 GS	08 - 18	674 HS* 675 LS
BMW F	800 GT	13 - 18	706 HS* 675 LS
BMW F	800 R	09 - 14	706 HS* 675 LS
BMW F	800 R	15 - 18	900 HS* 675 LS
BMW F	800 S	06 - 10	706 HS* 675 LS
BMW F	800 ST	06 - 12	706 HS* 675 LS
BMW F	800 ST Touring	11 - 12	706 HS* 675 LS
BMW R80	800	77 - 85	506 HF 2140
BMW R80	800	81	2139
BMW R80	800	86 - 88	554 HF 2140
BMW R80	800 G/S P.-D.	86	506 HF 2140
BMW R80	800 GS	81 - 87	506 HF 2140
BMW R80	800 GS	91 - 92	506 HS 2140
BMW R80	800 GS Mystic	91 - 95	554 HS* 2140
BMW R80	800 GS Paris Dakar	88 - 94	554 HS
BMW R80	800 R	91 - 95	644 HS* 506 LS
BMW R80	800 R	93 - 94	640 HS 2143
BMW R80	800 RT	83	506 HF* 2140
BMW R80	800 RT	85	554 HF* 2140
BMW R80/7	800	77 - 78	520 HF 2139
BMW R80/7	800	79 - 81	520 HF 506 HF
BMW F	850 GS	18 -	674 HS* 675 LS
BMW R	850 C	99 - 01	703 HS* 742 LS
BMW R	850 GS	99 - 07	703 HS* 742 LS
BMW R	850 R	96 - 02	703 HS* 742 LS
BMW R	850 R	03 - 07	778 HS* 742 LS
BMW R	850 RT	96 - 01	703 HS* 675 LS
BMW R	850 RT With Integral ABS	01 - 06	796 HS* 742 LS
BMW R90	900 S	73 - 76	520 HF* 2139
BMW R90	900 Series	74 - 80	2139
BMW R90/6	900	73 - 76	520 HF 2139
BMW K1	1000	89	644 HS* 506 LS
BMW K100	1000 LT	87	506 HF* 506 HF
BMW K100	1000 LT	92 - 94	644 HS* 506 LS
BMW K100	1000 LT ABS	89	640 HS* 506 LS
BMW K100	1000 RS	90 - 92	644 HS* 506 LS
BMW K100	1000 RS ABS	88 - 89	640 HS* 506 LS
BMW K100	1000 RS, RT	83 - 89	506 HF* 506 HF
BMW R100	1000	79 - 81	2139
BMW R100	1000	81 - 84	506 HF* 506 HF
BMW R100	1000 all models	81 - 84	2140
BMW R100	1000 CS,RS, RT	81 - 84	506 HF* 506 HF
BMW R100	1000 GS	87 - 94	554 HF 2140
BMW R100	1000 GS Mystic	91 - 94	554 HS* 2140
BMW R100	1000 R	91 - 95	644 HS* 506 LS
BMW R100	1000 R	92 - 95	644 HS* 2143
BMW R100	1000 RS	76 - 80	520 HF* 506 HF
BMW R100	1000 RS	93 - 95	640 HS* 506 LS
BMW R100	1000 RT	91 - 95	554 HS* 2143
BMW R100	1000 S	76 - 77	520 HF* 2139
BMW R100	1000 S	78 - 80	520 HF* 506 HF



**RECOMMENDED**

1xx = Scooter Pads  
5xx = Street, Off Road & Racing Pads  
2xxx = Brake Shoes



Model	Year	Front	Rear
BMW R100	1000 T	79 - 84	520 HF* 506 HF
BMW R100/7	1000	78 - 80	520 HF 2139
BMW S	1000 R	13 - 18	870 HS* 675 LS
BMW S	1000 RR	09 - 18	870 SP* 675 LS
BMW S	1000 RR HP4	12 - 14	901 SP* 675 LS
BMW S	1000 XR	15 - 18	900 SP* 742 LS
BMW K1100	1100 LT/SE	92 - 00	644 HS* 506 LS
BMW K1100	1100 RS	93 - 96	644 HS* 506 LS
BMW R	1100 GS	99	703 HS* 742 LS
BMW R	1100 R Cast wheels	99 - 01	703 HS* 742 LS
BMW R	1100 R Spoke wheels	99 - 06	703 HS* 742 LS
BMW R	1100 RT Cast wheels	95 - 01	703 HS* 742 LS
BMW R	1100 RT Spoke wheels	95 - 01	703 HS* 742 LS
BMW R	1100 S	99 - 00	703 HS* 742 LS
BMW R	1100 S With Integral ABS	01 - 05	778 HS* 742 LS
BMW R	1100 S Without Integral ABS	01 - 05	796 HS* 742 LS
BMW R1100	1100 GS	94 - 01	703 HS* 742 LS
BMW R1100	1100 RS	93	644 HS* 506 LS
BMW R1100	1100 RS	94 - 01	703 HS* 506 LS
BMW R	1150 GS	00 - 01	703 HS* 742 LS
BMW R	1150 GS (Brembo cal.)	02 - 05	778 HS* 742 LS
BMW R	1150 GS Adventurer (Tokico cal.)	02 - 05	796 HS* 742 LS
BMW R	1150 R	01 - 06	778 HS* 742 LS
BMW R	1150 R Rockster	03 - 05	778 HS* 742 LS
BMW R	1150 RS	01 - 04	778 HS* 742 LS
BMW R	1150 RT With Integral ABS	01 - 06	796 HS* 742 LS
BMW	1200 HP2 Enduro	04 - 06	674 HS* 671 LS
BMW	1200 HP2 Megamoto	06 - 08	796 HS* 742 LS
BMW	1200 HP2 Sport	08 - 10	901 SP* 671 LS
BMW K	1200 GT (K41) With Integral ABS	02 - 05	796 HS* 506 LS
BMW K	1200 GT (K44) With Integral ABS	04 - 08	796 HS* 671 LS
BMW K	1200 LT	99 - 00	703 HS* 746 HF
BMW K	1200 LT With Integral ABS	01 - 08	778 HS* 746 HF
BMW K	1200 R	05 - 08	778 HS* 742 LS
BMW K	1200 R Sport	05 - 07	778 HS* 742 LS
BMW K	1200 RS	97 - 00	703 HS* 506 LS
BMW K	1200 RS	01 - 05	796 HS* 506 LS
BMW K	1200 S	05 - 08	796 HS* 742 LS
BMW R	1200 C	98 - 02	703 HS* 742 LS
BMW R	1200 C Classic	03 - 04	778 HS* 742 LS
BMW R	1200 C Independent	03 - 04	778 HS* 742 LS
BMW R	1200 C Montauk	02 - 04	778 HS* 742 LS
BMW R	1200 CL	03 - 04	778 HS* 746 HF
BMW R	1200 GS	04 - 12	796 HS* 742 LS
BMW R	1200 GS	13 - 18	900 SP* 674 LS
BMW R	1200 GS Adventure	08 - 13	796 SP* 742 LS
BMW R	1200 GS Adventure	14 - 16	900 SP* 674 LS
BMW R	1200 GS Tripple Black	11 - 16	796 SP* 742 LS
BMW R	1200 Nine-T	14 - 18	900 HS* 671 LS
BMW R	1200 Nine-T Pure	17 - 18	706 HS* 671 LS
BMW R	1200 Nine-T Racer	17 - 18	706 HS* 671 LS
BMW R	1200 Nine-T Scrambler	16 - 18	706 HS* 671 LS
BMW R	1200 Nine-T Urban GS	17 - 18	706 HS* 671 LS
BMW R	1200 R	07 - 14	778 HS* 742 LS
BMW R	1200 R	15 - 18	900 HS* 674 LS
BMW R	1200 RS	14 - 18	900 HS* 674 LS
BMW R	1200 RT	06 - 13	796 HS* 742 LS
BMW R	1200 RT	14 - 18	900 HS* 674 LS
BMW R	1200 S	06 - 07	796 HS* 742 LS
BMW R	1200 ST	06 - 07	796 HS* 742 LS
BMW K	1300 GT	09 - 10	796 HS* 671 LS
BMW K	1300 R	09 - 15	778 SP* 742 LS
BMW K	1300 R Dynamic	11 - 15	778 SP* 742 LS
BMW K	1300 S	09 - 15	796 HS* 742 LS
BMW K	1600 B	17 - 18	778 HS* 674 LS

\* = 2 sets required / 2 jeux pour l'Avant.

Full compound selection, see under "Brake pad 1:1 Drawings" / Sélection complète de composés, voir "1:1 Schémas Plaquettes de frein".  
For ABE type approvals, see page 1 / Pour les homologations de type ABE, voir page 2.

**RECOMMENDED**1xx = Scooter Pads  
5xx = Street, Off Road & Racing Pads  
2xxx = Brake Shoes

<b>BMW</b>					
K	1600 Grand America	18 -	778 HS*	674 LS	
K	1600 GT	11 - 18	778 HS*	674 LS	
K	1600 GTL	11 - 18	778 HS*	674 LS	
<b>BOMBARDIER</b>					
	50 Quest	03 - 04	2048	2041	
DS	50	02 - 06	2048	2041	
	90 Quest	03 - 04	2048	2041	
DS	90	02 - 06	2048	2041	
	200 Rally 2x4	03 - 04	544 SI*		
	200 Rally 2x4	05 - 06	544 SI*	546 SI	
DS	250 Left/Rear	06	754 SI	754 SI	
DS	250 Right	06	767 SI		
	330 Outlander Left/Rear	03 - 06	754 SI	754 SI	
	330 Outlander Right	03 - 06	767 SI		
	400 Outlander Left/Rear	03 - 06	754 SI	754 SI	
	400 Outlander Max				
	Left/Rear	03 - 06	754 SI	754 SI	
	400 Outlander Max Right	03 - 06	767 SI		
	400 Outlander Right	03 - 06	767 SI		
	500 Quest Left/Rear	02 - 06	754 SI	754 SI	
	500 Quest Right	02 - 06	767 SI		
	500 Traxter 4x4	99 - 00	730 HF*	730 HF	
	500 Traxter 4x4 Left/Rear	01 - 06	754 SI	767 SI	
	500 Traxter 4x4 Right	01 - 06	767 SI		
	500 Traxter Max Left/Rear	03 - 05	754 SI	767 SI	
	500 Traxter Max Right	03 - 05	767 SI		
	650 Quest Left/Rear	02 - 06	754 SI	754 SI	
	650 Quest Max Left/Rear	03 - 06	754 SI	767 SI	
	650 Quest Max Right	03 - 06	767 SI		
	650 Quest Right	02 - 06	767 SI		
	650 Traxter Max Left/Rear	03 - 05	754 SI	767 SI	
	650 Traxter Max Right	03 - 05	767 SI		
DS	650 Left/Rear	01 - 06	754 SI	754 SI	
DS	650 Right	01 - 06	767 SI		
	800 Outlander Left/Rear	06	754 SI	754 SI	
	800 Outlander Right	06	767 SI		
	800 Outlander XT				
	Left/Rear	06	754 SI	754 SI	
	800 Outlander XT Right	06	767 SI		
<b>BRAMMO</b>					
	Empulse	14 - 16	706 HS*	730 LS	
<b>BUELL</b>					
	all models	94 - 97	658 HF	692 HF	
	500 Blast	01 - 09	627 HF	614 HF	
XB9R	984 Firebolt	02 - 10	795 HS	614 LS	
XB9S	984 Lightning	03 - 10	795 HS	614 LS	
XB9SX	984 CityX	05 - 10	795 HS	614 LS	
	1125 CR	09 - 10	856 HS	857 LS	
	1125 R	08 - 10	856 HS	857 LS	
M2	1200 Cyclone	98 - 02	676 HS	614 LS	
RS	1200	12	658 HF	692 HF	
S1	1200 Lightning	98 - 02	676 HS	614 LS	
S1	1200 Whitelighting	98 - 02	676 HS	614 LS	
S3	1200 Thunderbolt	98 - 02	676 HS	614 LS	
X1	1200 Lightning	01 - 02	676 HS	614 LS	
XB12R	1200 Firebolt	04 - 08	795 HS	614 LS	
XB12R	1200 Firebolt	09 - 10	856 HS	614 LS	
XB12S	1200 Lightning	04 - 08	795 HS	614 LS	
XB12Scg	1200 Lightning	06 - 08	795 HS	614 LS	
XB12Scg	1200 Lightning	09 - 10	856 HS	614 LS	
XB12Ss	1200 Lightning Long	06 - 08	795 HS	614 LS	
XB12Ss	1200 Lightning Long	09 - 10	856 HS	614 LS	
XB12STT	1200 Super TT	07 - 10	795 HS	614 LS	
XB12X	1200 Ulysses	06 - 10	795 HS	614 LS	

**RECOMMENDED**1xx = Scooter Pads  
5xx = Street, Off Road & Racing Pads  
2xxx = Brake Shoes

<b>CAGIVA</b>					
	50 AJP Caliper				
	incl. pin/spring	90 - 18	188 HF		
	125 Aletta Oro	86 - 89	519 HF*	519 HF	
	125 Blues	87 - 85	588 HF	519 HF	
	125 Cross	86	608 SI	692 SI	
	125 Cruiser	88 - 89	594 HF	519 HF	
	125 Cruiser	89	608 HF	574 HF	
	125 E2	86	574 HF		
	125 Elefant	81 - 88	574 HF		
	125 Enduro	86	519 HF		
	125 Raptor	03 - 10	566 HF	519 HF	
	125 SST	81	574 HF		
	125 Stella	97 - 08	103 CT		
	125 Tamanaco	87 - 92	608 HF	574 HF	
	125 Tamanaco	89	608 HF	519 HF	
WMX	125	88	608 SI		
WMX	125	89 - 90	608 SI	692 SI	
WMX	125 GP-Replica	86 - 89	519 SI		
WRX	125	85	519 HF		
	200 Aletta Electra	83	574 HF		
	200 Cross	83 - 86	574 HF		
	200 Elefant	86	519 HF		
	250 Cross	86	608 SI		
MXR	250	82	519 HF		
WMX	250	88	608 SI		
WMX	250	89 - 90	608 SI	692 SI	
WMX	250 GP	82	519 SI		
	350 Alazurra	85 - 86	519 HF	519 HF	
	350 Alazurra	87	519 HF*	519 HF	
	350 Elefant	86 - 89	594 HF	519 HF	
T4	350 R	87 - 99	519 HF	2026	
	500 Mito	07	566 HS	519 LS	
T4	500 E	87 - 90	519 HF	2026	
WMX	500	85 - 86	519 SI		
WMX	500 Cross	87	519 SI	519 SI	
SP	525 Mito	08 - 10	566 HS	519 LS	
	650 Alazurra	84	519 HF	519 HF	
	650 Alazurra	85 - 88	560 HF*	560 HF	
	650 Elefant	86 - 87	594 HF	519 HF	
	650 Raptor	01 - 08	706 HS*	730 LS	
	650 V-Raptor	01 - 08	706 HS*	730 LS	
	900 Canyon I.E.	97	647 HS	638 LS	
	900 Elefant	93 - 97	671 HF*	671 HF	
	900 Gran Canyon	99 - 04	627 HS*	638 LS	
	1000 Navigator, T	00 - 05	627 HS*	638 LS	
	1000 Raptor	00 - 08	706 HS*	730 LS	
	1000 V-Raptor	00 - 08	706 HS*	730 LS	
	1000 X3 Raptor	04	762 HS*	730 LS	
	1000 X-Raptor	03 - 04	762 HS*	730 LS	
	1000 Xtra Raptor	02 - 06	706 HS*	730 LS	
<b>CAN-AM</b>					
DS	50	07 - 11	2048	2041	
DS	70	08 - 14	2048	2041	
DS	90	07 - 18	2048	2041	
DS	90 X	08 - 18	544 SI*	544 SI	
	200 ASE	86	519 SI		
	250 ASE	86	519 SI		
	250 MX LC	86	519 SI		
DS	250	08 - 18	810 SI*	810 SI	
	350 ASE	86	519 SI		
	400 Outlander EFi				
	Left/Rear	09 - 14	754 SI	754 SI	
	400 Outlander EFi Right	09 - 14	767 SI		
	400 Outlander MAX STD				
	Left/Rear	07 - 13	754 SI	754 SI	
	400 Outlander MAX STD				
	Right	07 - 13	767 SI		

\* = 2 sets required / 2 jeux pour l'Avant.





**RECOMMENDED**

1xx = Scooter Pads  
 5xx = Street, Off Road & Racing Pads  
 2xxx = Brake Shoes



CAN-AM				
400	Outlander MAX XT Left/Rear	07 - 13	754 SI	754 SI
400	Outlander MAX XT Right	07 - 13	767 SI	
400	Outlander STD Left/Rear	07 - 14	754 SI	754 SI
400	Outlander STD Right	07 - 14	767 SI	
400	Outlander XT Left/Rear	07 - 14	754 SI	754 SI
400	Outlander XT Right	07 - 14	767 SI	
406	ASE	87	519 SI	
450	Outlander Left	15 - 18	911 SI	
450	Outlander Right/Rear	15 - 18	910 SI	910 SI
450	Outlander MAX Left	15 - 18	911 SI	
450	Outlander MAX Right/Rear	15 - 18	910 SI	910 SI
DS	450	08 - 12	907 SI*	908 SI
	500 ASE	86	519 SI	
	500 MX	86	519 SI	
	500 Outlander MAX STD Left/Rear	07 - 12	754 SI	754 SI
	500 Outlander MAX STD Right	07 - 12	767 SI	
	500 Outlander MAX XT Left/Rear	07 - 12	754 SI	754 SI
	500 Outlander MAX XT Right	07 - 12	767 SI	
	500 Outlander STD Left/Rear	07 - 12	754 SI	754 SI
	500 Outlander STD Right	07 - 12	767 SI	
	500 Outlander XT Left/Rear	07 - 12	754 SI	754 SI
	500 Outlander XT Right	07 - 12	767 SI	
	500 Outlander Left	13 - 14	911 SI	
	500 Outlander Right/Rear	13 - 14	910 SI	910 SI
	500 Outlander MAX Left	13 - 14	911 SI	
	500 Outlander MAX Right/Rear	13 - 14	910 SI	910 SI
	500 Renegade Left/Rear	08 - 11	754 SI	754 SI
	500 Renegade Right	08 - 11	767 SI	
	500 Renegade Left/Rear	12 - 14	911 SI	911 SI
	500 Renegade Right/Rear	12 - 14	910 SI	910 SI
	560 Sonic	86 - 14	519 SI	
	650 Outlander 6x6 Left/Rear	14 - 18	911 SI	911 SI
	650 Outlander 6x6 Right/Rear	14 - 18	910 SI	910 SI
	650 Outlander MAX STD Left/Rear	07 - 12	754 SI	754 SI
	650 Outlander MAX STD Right	07 - 12	767 SI	
	650 Outlander MAX XT Left/Rear	07 - 12	754 SI	754 SI
	650 Outlander MAX XT Right	07 - 12	767 SI	
	650 Outlander STD Left/Rear	07 - 12	754 SI	754 SI
	650 Outlander STD Right	07 - 12	767 SI	
	650 Outlander XT Left/Rear	07 - 12	754 SI	754 SI
	650 Outlander XT Right	07 - 12	767 SI	
	650 Outlander Left	13 - 15	911 SI	
	650 Outlander Right/Rear	13 - 15	910 SI	910 SI
	650 Outlander MAX Left	13 - 15	911 SI	
	650 Outlander MAX Right/Rear	13 - 15	910 SI	910 SI
	800 Commander Left/Rear	11 - 14	638 SI	611 SI
	800 Commander Right	11 - 14	611 SI	
	800 Outlander MAX LTD Left/Rear	07 - 11	754 SI	754 SI



**RECOMMENDED**

1xx = Scooter Pads  
 5xx = Street, Off Road & Racing Pads  
 2xxx = Brake Shoes



CAN-AM				
800	Outlander MAX LTD Right	07 - 11	767 SI	
800	Outlander MAX STD Left/Rear	07 - 11	754 SI	754 SI
800	Outlander MAX STD Right	07 - 11	767 SI	
800	Outlander MAX XT Left/Rear	07 - 11	754 SI	754 SI
800	Outlander MAX XT Right	07 - 11	767 SI	
800	Outlander STD Left/Rear	07 - 11	754 SI	754 SI
800	Outlander STD Right	07 - 11	767 SI	
800	Outlander XT Left/Rear	07 - 11	754 SI	754 SI
800	Outlander XT Right	07 - 11	767 SI	
800	Outlander Left	12 - 15	911 SI	
800	Outlander Right/Rear	12 - 15	910 SI	910 SI
800	Outlander MAX Left	13 - 14	911 SI	
800	Outlander MAX Right/Rear	13 - 14	910 SI	910 SI
800	Renegade EFi Left/Rear	07 - 11	754 SI	754 SI
800	Renegade EFi Right	07 - 11	767 SI	
800	Renegade Left/Rear	08 - 11	754 SI	754 SI
800	Renegade Right	08 - 11	767 SI	
800	Renegade X Left/Rear	08 - 11	754 SI	754 SI
800	Renegade X Right	08 - 11	767 SI	
800	Renegade Left/Rear	12 - 15	911 SI	911 SI
800	Renegade Right/Rear	12 - 15	910 SI	910 SI
1000	Commander Left/Rear	11 - 14	638 SI	611 SI
1000	Commander Right	11 - 14	611 SI	
1000	Commander MAX Left	14 - 18	638 SI	754 SI
1000	Commander MAX Right	14 - 18	611 SI	767 SI
1000	Maverick Left	13 - 18	638 SI	754 SI
1000	Maverick Right	13 - 18	611 SI	767 SI
1000	Outlander 6x6 Left/Rear	14 - 18	911 SI	911 SI
1000	Outlander 6x6 Right/Rear	14 - 18	910 SI	910 SI
1000	Outlander Left	12 - 15	911 SI	
1000	Outlander Right/Rear	12 - 15	910 SI	910 SI
1000	Outlander MAX Left	12 - 18	911 SI	
1000	Outlander MAX Right/Rear	12 - 18	910 SI	910 SI
1000	Renegade Left/Rear	12 - 18	911 SI	911 SI
1000	Renegade Right/Rear	12 - 18	910 SI	910 SI
1330	Spyder F3	15 - 18	900 HS*	948 HS
1330	Spyder F3 Limited	16 - 18	900 HS*	948 HS
1330	Spyder F3-S	15 - 18	900 HS*	948 HS
1330	Spyder F3-T	16 - 18	900 HS*	948 HS
1330	Spyder RS	14 - 16	900 HS*	948 HS
1330	Spyder RS RSS	13	900 HS*	948 HS
1330	Spyder RSS	14 - 15	900 HS*	948 HS
1330	Spyder RSS Special Series	15	900 HS*	948 HS
1330	Spyder RT	14 - 18	900 HS*	948 HS
1330	Spyder RT Limited	13 - 18	900 HS*	948 HS
1330	Spyder RT RTS	13	900 HS*	948 HS
1330	Spyder RTS	14 - 15	900 HS*	948 HS
1330	Spyder RTS Special Series	15	900 HS*	948 HS
1330	Spyder ST	14 - 16	900 HS*	948 HS
1330	Spyder ST Limited	13 - 15	900 HS*	948 HS
1330	Spyder ST STS	13	900 HS*	948 HS
1330	Spyder STS	14 - 15	900 HS*	948 HS
1330	Spyder STS Special Series	15	900 HS*	948 HS

\* = 2 sets required / 2 jeux pour l'Avant.

Full compound selection, see under "Brake pad 1:1 Drawings" / Sélection complète de composés, voir "1:1 Schémas Plaquettes de frein".  
 For ABE type approvals, see page 1 / Pour les homologations de type ABE, voir page 2.

**RECOMMENDED**1xx = Scooter Pads  
5xx = Street, Off Road & Racing Pads  
2xxx = Brake Shoes

CANNONDALE					
MX	400	00 - 03	694 RSI	632 RSI	
	440 Blaze Left/Rear	03	754 SI	754 SI	
	440 Blaze Right	03	767 SI		
	440 Cannibal Left/Rear	03	754 SI	754 SI	
	440 Cannibal Right	03	767 SI		
	440 Glamis Left/Rear	03	754 SI	754 SI	
	440 Glamis Right	03	767 SI		
	440 Moto Left/Rear	03	754 SI	754 SI	
	440 Moto Right	03	767 SI		
	440 Speed Left/Rear	03	754 SI	754 SI	
	440 Speed Right	03	767 SI		
C	440 R	03	694 RSI	632 RSI	
E	440 , A, R	03	694 RSI	632 RSI	
S	440	03	566 HF	632 HF	
X	440	03	694 RSI	632 RSI	
CCM					
	450 MX	08 - 10	671 RSI	790 RSI	
GP	450	16	671 SI	675 SI	
604	600 RS	01	671 HF	675 HF	
604E	600 Sport	99 - 01	671 SI	675 SI	
604E	600 Supermoto	99 - 01	671 SI	675 SI	
C25	600	96 - 98	671 SI	675 SI	
	644 DS	03 - 06	671 HF	675 HF	
	644 R30	02 - 06	671 HF	675 HF	
CECTEK					
	500 EFI Gladiator	09 - 13	810 HF*	544 HF	
	500 EFI King Cobra	09 - 13	878 HF*	544 HF	
	500 EFI Quadrift	09 - 11	878 HF*	544 HF	
	500 i Estoc	10	878 HF*	544 HF	
CF MOTO					
	125 Papio	17	688 HF	784 HF	
	400 NK Efi	17	674 HS*	675 LS	
	450 C-Force L	16 - 17	914 SI*	799 SI	
	450 G-Force L	16 - 17	914 SI*	799 SI	
CF	500 Terralander	13 - 15	914 SI*	799 SI	
	550 C-Force	16 - 17	914 SI*	799 SI	
	550 U-Force Left	15 - 16	638 SI		
	550 U-Force Right	15 - 16	611 SI		
	550 Z-Force Left	15 - 16	638 SI		
	550 Z-Force Right	15 - 16	611 SI		
CF	625 Terralander	11 - 15	914 SI*	799 SI	
	650 NK	14 - 16	674 HS*	675 LS	
	650 NK Efi	17	674 HS*	675 LS	
	650 TK	14 - 15	674 HS*	675 LS	
	800 Z-Force EX Left	15	638 SI		
	800 Z-Force EX Right	15	611 SI		
CF	800 Terralander	12 - 14	914 SI*	799 SI	
COBRA					
CX	50 Big Wheel	10 - 14	794 RSI	794 RSI	
CX	50 Junior	07 - 10	794 RSI		
CX	50 Junior	11 - 13	794 RSI	794 RSI	
CX	50 Senior	07 - 13	794 RSI	794 RSI	
CPI					
	50 Aragon Club	07 - 09	141 HF		
	50 Aragon GP	06 - 09	141 HF		
	50 Aragon SP	07 - 09	141 HF		
	50 Baby	02	101 HF	2028	
	50 Freaky	07	141 HF		
	50 GTR	02	120 HF		
	50 GTR	03 - 09	157 HF	123 HF	
	50 GTS	02 - 03	120 HF	145 HF	
	50 Hussar	01 - 02	101 HF	2028	
	50 Hussar	03 - 06	141 HF	2028	

**RECOMMENDED**1xx = Scooter Pads  
5xx = Street, Off Road & Racing Pads  
2xxx = Brake Shoes

CPI					
	50 Mars	01 - 02	101 HF	2028	
	50 Oliver	03 - 12	141 HF	2028	
	50 Oliver City	03 - 12	141 HF	2028	
	50 Oliver Sport	03 - 12	141 HF	2028	
	50 Popcorn	01 - 02	101 HF	2028	
	50 Popcorn	03 - 06	141 HF	2032	
	50 Supermoto, Supercross	03 - 09	105 HF	105 HF	
	125 Aragon GP	07 - 12	141 CT		
	125 GTR, GTS	02 - 03	120 CT	143 CT	
	125 Sahel	02	694 HF	604 HF	
	125 Supermoto	07 - 12	559 HF		
	125 X-Large	02 - 03	157 CT*	157 CT	
	200 GTR, GTS	02 - 03	120 CT	143 CT	
	200 X-Large	02 - 03	157 CT*	157 CT	
	250 XS ATV	07 - 08	810 SI*		
XS	250 Quad	06 - 08	544 SI*	848 SI	
DERBI					
	50 AJP Caliper incl. pin/spring	90 - 18	188 HF		
	50 Atlantis	99 - 08	105 HF	2181	
	50 Atlantis 4T	04 - 10	105 HF		
	50 Atlantis Bullet	04 - 05	105 HF		
	50 Atlantis H2O	01	105 HF		
	50 Atlantis H2O Wave	01	105 HF		
	50 Atlantis Wave	01 - 02	105 HF		
	50 Aventura	96	105 HF	2206	
	50 Black Devil	04	168 HF	105 HF	
	50 Boulevard	09 - 13	177 HF		
	50 DRD Pro corse	06 - 08	189 MS	105 HF	
	50 DRD Racing R	05 - 10	168 HF	105 HF	
	50 DRD Racing R Ltd.	05	168 HF	105 HF	
	50 DRD Racing SM	05	168 HF	105 HF	
	50 DRD Racing SM Ltd.	05	168 HF	105 HF	
	50 Easy	96 - 98	138 HF	2181	
	50 Fenix	94 - 07	105 HF	105 HF	
	50 Furax	96 - 98	105 HF	105 HF	
	50 Hunter	97 - 99	105 HF	2181	
	50 Manhattan	99	105 HF	2181	
	50 Predator LC	99 - 02	105 HF	105 HF	
	50 Predator O2	00 - 02	105 HF	105 HF	
	50 Rambla	06	105 HF	105 HF	
	50 Savannah	91 - 97	105 HF		
	50 Senda DRD Pro SM	05 - 11	157 HF	167 HF	
	50 Senda L	99 - 01	105 HF	105 HF	
	50 Senda R DRD	03 - 04	148 HF*	105 HF	
	50 Senda R, X-Treme	94 - 04	105 HF	105 HF	
	50 Senda SM DRD	03 - 04	105 HF*	105 HF	
	50 Senda SM DRD Black Edition	03 - 04	168 HF	105 HF	
	50 Senda SM, X-Treme	99 - 06	105 HF	105 HF	
	50 Sonar	10 - 11	142 HF		
	50 Stinger	96	105 HF		
	50 Vamos FL	95 - 99	105 HF	2181	
	50 Vamos L	95	105 HF	2181	
	50 Vamos R (A.J.P. cal.)	95	105 HF	2206	
	50 Vamos R (Brembo cal.)	95	123 HF	2206	
	50 Variant Sport-R	01 - 13	105 HF	2206	
	50 X-Race R	05 - 09	105 HF	105 HF	
	50 X-Treme R	05	105 HF	105 HF	
DS	50	88	559 HF		
FD	50 Yumbo	84	559 HF		
FD	50 Yumbo	84	625 HF		
FD	50 Yumbo Extra	84	625 HF		
FD	50 Yumbo Extra	87	559 HF		
FDS	50	84	625 HF		
FDS	50	87	559 HF		

\* = 2 sets required / 2 jeux pour l'Avant.





**RECOMMENDED**

1xx = Scooter Pads  
5xx = Street, Off Road & Racing Pads  
2xxx = Brake Shoes



DERBI				
FDT	50	84	625 HF	
FDT	50	87 - 85	559 HF	
FDT	50 Coppa	85	559 HF	
FDX	50	89	559 HF	
GP	50	01	105 HF	
GP1	50	01 - 03	105 HF	105 HF
GP1	50	05	730 HF	559 HF
GPR	50 Nude	04 - 10	730 HF	559 HF
GPR	50 R	98 - 03	148 HF	105 HF
GPR	50 Racing	04 - 13	730 HF	559 HF
GPX1	50	06	189 MS	105 HF
ST	50 Paddock	96 - 99	105 HF	2181
	75 1001, 1002	81	625 HF	625 HF
	75 GPR	89	607 HF	559 HF
	75 Sport, Coppa	84	559 HF	
	75 Sport, Coppa	84	625 HF	
GPR	75 Sport	92	607 HF	559 HF
GPR	80 Cup	04 - 05	821 HS	559 HF*
	100 Atlantis 4T	04 - 06	105 HF	
	100 Atlantis O2/H2O	01	105 HF	
	125 Atmosphere	99	148 CT	
	125 Boulevard	03 - 07	167 CT	2205
	125 Mulhacen	07	774 HF	519 HF
	125 Mulhacen	08 - 11	859 HF	585 HF
	125 Predator	99	105 CT	
	125 Rambla	08 - 14	108 CT	152 CT
	125 Senda Baja	06 - 12	168 HF	167 CT
	125 Senda DRD SM	10 - 14	157 HF	203 HF
	125 Senda R 4T	04 - 12	774 HF	559 HF
	125 Senda X-Treme SM 4T	04 - 05	774 HF	559 HF
	125 Terra	07	559 HF	519 HF
	125 Terra	08 - 13	859 HF	585 HF
	125 Terra Adventure	08 - 14	859 HF	585 HF
GP1	125	05 - 06	730 HF	559 HF
GPR	125	05 - 06	821 HS	559 HF*
GPR	125 Nude	05 - 08	821 HS	559 HF*
GPR	125 Racing	09	821 HS	559 HF*
	150 Boulevard	03 - 09	167 CT	2205
	180 Predator	99	148 CT	
DXR	200 Quad (Front disc)	04 - 07	544 SI*	586 SI
DXR	200 Quad (Front drum)	04 - 05	2028	586 SI
DXR	200 Quad (Front drum)	04 - 05	2028	611 SI
	250 RC	85	519 HF	
	250 T	82	625 HF	
DXR	250 Quad (Front disc)	04 - 07	544 SI*	586 SI
DXR	250 Quad (Front drum)	04 - 05	2028	586 SI
DXR	250 Quad (Front drum)	04 - 05	2028	611 SI
GP1	250	05 - 09	730 HF	772 HF
	300 Rambla	08 - 12	108 MS	152 MS
	659 Mulhacen	05	788 HS	730 LS
	659 Mulhacen	06 - 07	762 HS	730 LS
	659 Mulhacen Cafe	08	762 HS	730 LS
DUCATI				
	250 Desmo	70 - 77	506 HF	
	350	75 - 78	519 HF	
	350 Desmo	70 - 77	506 HF	
	350 F3	86 - 89	506 HF*	506 HF
	350 F3	86 - 90	519 HF*	519 HF
	350 GTV	77	519 HF	519 HF
	350 Indiana	86 - 91	594 HF	519 HF
	350 Paso	86	519 HF*	519 HF
	350 Sport	77 - 80	519 HF*	519 HF
	400 Monster (Japan)	01 - 06	706 HS	519 LS
	400 Scrambler Sixty Two	16 - 18	674 HS	675 LS
	400 SS, Junior	92 - 97	566 HF*	519 HF
	400 SS, Nuda	92 - 96	566 HF	519 HF
	500 GTV	77 - 82	519 HF*	519 HF



**RECOMMENDED**

1xx = Scooter Pads  
5xx = Street, Off Road & Racing Pads  
2xxx = Brake Shoes



DUCATI				
	500 Pantah	85 - 89	519 HF*	519 HF
	500 Sport	77 - 82	506 HF*	506 HF
	500 Sport Desmo	77 - 82	519 HF*	
	500 Twin GTL	75 - 80	519 HF	
	502 Single	93	566 HF*	519 HF
	502 Supermono	93	566 HF*	519 HF
	600 Monster	00 - 01	706 HS	519 LS
	600 Pantah TL, SL	78 - 89	506 HF*	506 HF
	600 SL, TL Pantah	76 - 89	506 HF*	519 HF
	600 SS Supersport	95 - 00	566 HF	519 HF
M	600 Monster	94 - 99	566 HF	519 HF
	620 Monster Dark i.e.	02 - 06	706 HS	519 LS
	620 Monster i.e., s.i.e.	02 - 06	706 HS*	519 LS
	620 Multistrada	05 - 06	671 HS*	730 LS
	620 Multistrada Dark	05 - 06	706 HS	730 LS
	620 Sport	03 - 06	706 HS*	730 LS
	650 Indiana	86 - 89	594 HF	519 HF
	650 Pantah	84 - 89	506 HF*	506 HF
	695 Monster	07 - 12	671 HS*	519 LS
	696 Monster	08 - 12	706 HS*	730 LS
	748 , S	99 - 02	706 HS*	519 LS
	748 Biposto	95 - 98	566 HF*	519 HF
	748 R	00	706 HS*	519 LS
	748 R	01 - 02	762 HS*	519 LS
	748 SP	95 - 97	566 HF*	519 HF
	748 SPS	98 - 99	706 HS*	519 LS
	749 , S	03 - 07	762 HS*	730 LS
	749 R	04 - 07	762 HS*	730 LS
	750 F1	86 - 98	506 HF*	506 HF
	750 GT	74 - 76	506 HF*	
	750 Indiana	85 - 86	594 HF	519 HF
	750 Monster	96 - 99	566 HF*	519 HF
	750 Monster	00 - 01	706 HS*	519 LS
	750 Monster i.e.	02	706 HS*	519 LS
	750 Paso	86	519 HF*	519 HF
	750 Paso	87	506 HF*	519 HF
	750 Paso	88	519 HF*	519 HF
	750 Sport	74 - 76	523 HF*	
	750 Sport	90	506 HS*	506 LS
	750 Sport	00 - 02	706 HS	730 LS
	750 SS	74 - 76	506 HF*	506 HF
	750 SS	91 - 98	566 HF	506 HF
	750 SS Supersport	95 - 99	566 HF	519 HF
	750 SS, Carenara	92 - 98	566 HF	519 HF
	750 SS, Nuda	92	566 HF	519 HF
	750 Super Sport	92 - 94	566 HF*	519 HF
	750 Super Sport	00 - 02	706 HS*	730 LS
	795 Monster	12	706 HS*	730 LS
	796 Hypermotard ABS	10 - 12	706 HS*	730 LS
	796 Monster	11 - 14	706 HS*	730 LS
	796 Monster ABS	11 - 14	706 HS*	730 LS
	797 Monster	17 - 18	900 HS	675 LS
	797 Monster+	17 - 18	900 HS	675 LS
	800 Hypermotard	13 - 15	900 HS*	730 LS
	800 Hypermotard ABS	13 - 15	900 HS*	730 LS
	800 Hypermotard SP	13 - 15	900 HS*	730 LS
	800 Hypermotard SP ABS	13 - 15	900 HS*	730 LS
	800 Hyperstrada	13 - 15	900 HS*	730 LS
	800 Hyperstrada ABS	13 - 15	900 HS*	730 LS
	800 Monster Dark i.e., s.i.e.	03 - 07	706 HS*	519 LS
	800 Monster i.e., s.i.e.	03 - 07	706 HS*	519 LS
	800 Monster S2R	05 - 07	671 HS*	519 LS
	800 Monster S2R ABS	05 - 07	671 HS*	519 LS
	800 Scrambler	17 - 18	900 HS	675 LS
	800 Scrambler Classic	15 - 18	900 HS	675 LS
	800 Scrambler CR	17 - 18	900 HS	675 LS
	800 Scrambler CR			
	Cafe Racer	17 - 18	900 HS	675 LS

\* = 2 sets required / 2 jeux pour l'Avant.

Full compound selection, see under "Brake pad 1:1 Drawings" / Sélection complète de composés, voir "1:1 Schémas Plaquettes de frein".  
For ABE type approvals, see page 1 / Pour les homologations de type ABE, voir page 2.

**RECOMMENDED**1xx = Scooter Pads  
5xx = Street, Off Road & Racing Pads  
2xxx = Brake Shoes

DUCATI			900 HS	675 LS
	800 Scrambler Enduro	15 - 16	900 HS	675 LS
	800 Scrambler Flat			
	Track Pro	16	900 HS	675 LS
	800 Scrambler Full Throttle	15 - 18	900 HS	675 LS
	800 Scrambler Icon	15 - 18	900 HS	675 LS
	800 Scrambler Mach 2.0	18 -	900 HS	675 LS
	800 Scrambler			
	Street Classic	17 - 18	900 HS	675 LS
	800 Scrambler			
	Urban Enduro	16	900 HS	675 LS
	800 Scrambler-X DS			
	Desert Sled	17 - 18	900 HS	675 LS
	800 Sport	03 - 06	706 HS*	730 LS
	800 Supersport	03 - 06	706 HS*	730 LS
	821 Monster	14 - 18	900 HS*	730 LS
	821 Monster Dark	15 - 16	900 HS*	730 LS
	848	08 - 10	706 HS*	730 LS
	848 EVO	11 - 12	841 HS*	730 LS
	848 Streetfighter	12 - 15	706 HS*	730 LS
	848 Streetfighter S	12 - 15	841 HS*	730 LS
	851 Strada	89	566 HF*	519 HF
	851 Strada	91 - 92	566 HF*	506 HF
	851 Superbike	90	566 HF*	519 HF
	860 GT	75 - 77	506 HF	
	860 GT	85	506 HF	506 HF
	888 Roche Replica	91	566 HF*	506 HF
	888 SP V	93	566 HF*	519 HF
	888 SP4	92 - 95	566 HF*	519 HF
	888 SPO	93	566 HF*	519 HF
	888 SPS	92 - 95	566 HF*	519 HF
	888 Strada	93	566 HF*	519 HF
	888 Superbike	93	566 HF*	519 HF
	899 Panigale	14 - 15	900 HS*	730 LS
	900 FE	97 - 98	566 HF*	519 HF
	900 GTS	77 - 79	506 HF	
	900 M, IL Monster	93 - 99	566 HF*	519 HF
	900 Mike Hailwood Replica	85 - 86	506 HF*	506 HF
	900 Monster	00 - 01	706 HS*	519 LS
	900 Monster i.e.	02	706 HS*	519 LS
	900 S2 Desmo	85	506 HF*	506 HF
	900 SL	92 - 97	566 HF*	519 HF
	900 Sport	77 - 78	506 HF*	506 HF
	900 SS	78 - 89	506 HF*	506 HF
	900 SS	90 - 94	566 HF*	519 HF
	900 SS Supersport	95 - 97	566 HF	519 HF
	900 SSR	92	566 HF*	519 HF
	900 Super Sport	98 - 02	706 HS*	730 LS
906	900 Paso	89	506 HF*	519 HF
907	900 I. E.	90 - 93	566 HF*	519 HF
M	900 Street Monster	94 - 99	566 HF*	519 HF
MH	900	00 - 01	706 HS*	519 LS
	916 Biposto	94	566 HF*	519 HF
	916 Monster S4	01 - 03	706 HS*	519 LS
	916 Sport Touring 4	99 - 01	706 HS*	730 LS
	916 SPS	97 - 98	706 HS*	519 LS
	939 Hypermotard	16 - 18	900 HS*	730 LS
	939 Hypermotard SP	16 - 18	900 HS*	730 LS
	939 Hyperstrada	16	900 HS*	730 LS
	939 SuperSport	17 - 18	900 HS*	730 LS
	939 SuperSport S	17 - 18	900 HS*	730 LS
	944 Sport Touring	98 - 03	706 HS*	730 LS
	944 ST2	97 - 03	706 HS*	730 LS
	950 Multistrada	17 - 18	900 HS	671 LS
	959 Panigale	16 - 18	900 HS*	730 LS
	959 Panigale Corse	18 -	900 HS*	730 LS
D16RR	990 Desmosedici RR	07 - 08	841 HS*	730 LS
	992 ST3	04 - 07	706 HS*	730 LS
	992 ST3s ABS	06 - 07	706 HS*	730 LS

**RECOMMENDED**1xx = Scooter Pads  
5xx = Street, Off Road & Racing Pads  
2xxx = Brake Shoes

DUCATI			706 HS*	519 LS
	996 , SPS	99 - 01	706 HS*	519 LS
	996 Monster S4R	04 - 06	706 HS*	519 LS
	996 R	01	762 HS*	519 LS
	996 ST4s	02 - 06	706 HS*	730 LS
	996 ST4s ABS	03 - 06	706 HS*	730 LS
	998 , S	02	706 HS*	519 LS
	998 Monster S4Rs	06	762 HS*	730 LS
	998 R	02	762 HS*	519 LS
	999 , S	03 - 07	762 HS*	730 LS
	999 Monster S4R	07 - 08	762 HS*	730 LS
	999 Monster S4RS	07 - 08	762 HS*	730 LS
	999 R	03 - 07	762 HS*	730 LS
	1000 /6 Mike Hailwood			
	Replica	85	506 HF*	506 HF
	1000 Biposto	07 - 08	674 HS*	675 LS
	1000 GT	05 - 10	674 HS*	675 LS
	1000 GT Touring	09 - 10	674 HS*	675 LS
	1000 Hypermotard	06	762 HS*	730 LS
	1000 Mille Replica	84 - 85	506 HF*	506 HF
	1000 Monster Dark i.e., s i.e.	03 - 06	706 HS*	519 LS
	1000 Monster i.e., s i.e.	03 - 06	706 HS*	519 LS
	1000 Monster S2R	06 - 07	706 HS*	730 LS
	1000 Multistrada	07	706 HS*	730 LS
	1000 Multistrada DS	03 - 06	706 HS*	730 LS
	1000 Multistrada S DS	05 - 06	706 HS*	730 LS
	1000 Paul Smart	05 - 08	674 HS*	675 LS
	1000 S2 Desmo	85	506 HF*	506 HF
	1000 Sport, Sport S	05 - 09	674 HS*	675 LS
	1000 Supersport DS	03 - 06	706 HS*	730 LS
	1098	07 - 08	841 HS*	730 LS
	1098 R	08 - 10	841 SP*	730 LS
	1098 R Bayliss LE	09 - 10	841 SP*	730 LS
	1098 S	07 - 08	841 HS*	730 LS
	1098 Streetfighter	09 - 14	841 HS*	730 LS
	1098 Streetfighter S	09 - 13	841 HS*	730 LS
	1100 Hypermotard	07 - 13	841 HS*	730 LS
	1100 Hypermotard EVO	10 - 13	706 HS*	730 LS
	1100 Hypermotard EVO SP	10 - 12	841 HS*	730 LS
	1100 Monster	09 - 13	706 HS*	730 LS
	1100 Monster ABS	09 - 10	706 HS*	730 LS
	1100 Monster EVO	11 - 13	706 HS*	730 LS
	1100 Monster EVO ABS	11 - 13	706 HS*	730 LS
	1100 Monster S	09 - 13	706 HS*	730 LS
	1100 Monster S ABS	09 - 10	706 HS*	730 LS
	1100 Multistrada	07 - 09	706 HS*	730 LS
	1100 Multistrada S	07 - 09	706 HS*	730 LS
	1100 Panigale V4	18 -	841 SP*	730 LS
	1100 Panigale V4 S	18 -	841 SP*	730 LS
	1100 Panigale V4 Speciale	18 -	841 SP*	730 LS
	1100 Scrambler	18 -	900 HS*	675 LS
	1100 Scrambler Special	18 -	900 HS*	675 LS
	1100 Scrambler Sport	18 -	900 HS*	675 LS
	1198	09 - 13	841 SP*	730 LS
	1198 S	09 - 12	841 SP*	730 LS
	1198 SP	11 - 12	841 SP*	730 LS
	1199 Panigale	12 - 14	841 SP*	730 LS
	1199 Panigale R	13 - 15	841 SP*	730 LS
	1199 Panigale S	12 - 14	841 SP*	730 LS
	1199 Superleggera	14	841 SP*	730 LS
	1200 Diavel	11 - 18	901 HS*	674 LS
	1200 Diavel Strada	11 - 14	901 HS*	674 LS
	1200 Monster	14 - 18	900 HS*	730 LS
	1200 Monster R	16 - 18	841 HS*	730 LS
	1200 Monster S	14 - 18	841 HS*	730 LS
	1200 Multistrada	10 - 14	706 SP*	730 LS
	1200 Multistrada	15 - 16	900 SP*	671 LS
	1200 Multistrada Enduro	16 - 18	900 SP*	671 LS
	1200 Multistrada Enduro Pro	18 -	900 SP*	671 LS

\* = 2 sets required / 2 jeux pour l'Avant.





**RECOMMENDED**

1xx = Scooter Pads  
5xx = Street, Off Road & Racing Pads  
2xxx = Brake Shoes



DUCATI				
1200	Multistrada S	15 - 17	841 SP*	671 LS
1200	Multistrada S D-air	15 - 17	841 SP*	671 LS
1200	Multistrada S GT	12 - 14	706 SP*	730 LS
1200	Multistrada S			
	Pikes Peak	11 - 14	706 SP*	730 LS
1200	Multistrada S			
	Pikes Peak	16 - 17	841 SP*	671 LS
1200	Multistrada S Sport	10 - 14	706 SP*	730 LS
1200	Multistrada S Touring	10 - 14	706 SP*	730 LS
1200	Xdiavel	16 - 18	901 HS*	674 LS
1200	Xdiavel S	16 - 18	901 HS*	674 LS
1260	Multistrada	18 -	841 SP*	671 LS
1260	Multistrada S	18 -	841 SP*	671 LS
1260	Multistrada S D-air	18 -	841 SP*	671 LS
1260	Multistrada S			
	Pikes Peak	18 -	841 SP*	671 LS
1299	Panigale	15 - 17	841 SP*	730 LS
1299	Panigale R	15 - 17	841 SP*	730 LS
1299	Panigale R			
	Final Edition	17 - 18	841 SP*	730 LS
1299	Panigale S	15 - 17	841 SP*	730 LS
1299	Panigale S			
	Anniversario	17	841 SP*	730 LS
1299	Superleggera	17	841 SP*	730 LS
EBR				
1190	RS	12 - 15	856 HS	857 LS
1190	RX	14 - 15	856 HS	857 LS
1190	SX	14 - 15	856 HS	857 LS
E-TON				
RXL	150 Viper	07	2012	847 SI
VXL	250 Vector, ST Vector	06 - 07	544 SI*	847 SI
VTX	300 Vortex, ST Vortex	07	544 SI*	847 SI
VXL	300 Vector, ST Vector	07 - 13	544 SI*	847 SI
EXCELSIOR-HENDERSON				
1386	Deadwood Special	00	739 H.HS	739 H.LS
1386	Super X all models	99	739 H.HS	739 H.LS
FANTIC				
125	Caballero Flat Track	17	877 HS	675 LS
125	Trial Professional	87	595 HF	595 HF
125	Trial Progress 1	87	595 HF	
HP1	125 Sport	86	560 HF*	
HP1	125 Sport	87	574 HF*	
HP1	125 Strada	85	595 HF	
201	Trial Progress 2	87	595 HF	
241	Trial Progress 2	87	595 HF	
243	Trial	87 - 90	595 HF	595 HF
250	Coach	91 - 98	519 HF	
250	K-Roo	93 - 95	559 RSI	559 RSI
250	Raider	85	588 HF	
301	Trial	85 - 91	595 HF	
301	Trial Progress 2	87	595 HF	
303	Trial Professional	87	595 HF	595 HF
305		89 - 90	559 RSI	559 RSI
307	Trial	91 - 94	559 RSI	559 RSI
343	Trial Progress 2	87	595 HF	595 HF
500	Caballero	17	900 HS	675 LS
GAS GAS				
TXT	50 Wild HP	04 - 07	671 SI*	671 SI
TXT	50 Boy	01	815 HF	815 HF
TXT	50 Boy	04	559 RSI	559 RSI
TXT	50 Rookie	02 - 03	815 HF	815 HF
MC	65	05 - 06	815 HF	815 HF
TXT	80 Rookie	02 - 03	815 HF	815 HF



**RECOMMENDED**

1xx = Scooter Pads  
5xx = Street, Off Road & Racing Pads  
2xxx = Brake Shoes



GAS GAS				
125	Delta	91	559 HF	
125	Enducross	93	694 SI	586 SI
125	Pampera	96 - 03	559 RSI	559 RSI
125	Pampera	04 - 13	774 HF	815 HF
125	Trial	91	559 RSI	
EC	125	97 - 99	671 SI	675 SI
EC	125	00 - 06	694 SI	604 SI
MC	125	03 - 13	694 RSI	604 RSI
SM	125	02 - 13	566 HF	604 HF
TX	125 Randone	12 - 13	802 RSI	803 RSI
TXT	125 (Formula cal.)	12 - 13	885 RSI	803 RSI
TXT	125	04 - 13	802 RSI	803 RSI
TXT	125 Pro Racing	14	939 RSI	803 RSI
TXT	125 Pro Replica	13	939 RSI	803 RSI
200	Pampera	99 - 08	559 RSI	559 RSI
200	Wild HP	08 - 09	671 SI*	671 SI
EC	200	99	671 SI	675 SI
EC	200	00 - 09	694 SI	604 SI
EC	200	17	694 SI	790 SI
EC	200 Hobby	07 - 16	694 SI	604 SI
TX	200	97 - 98	559 RSI	559 RSI
TXT	200	04 - 10	802 RSI	803 RSI
XC	200	18 -	694 SI	790 SI
240	Wild HP	04 - 06	671 SI*	671 SI
250	Pampera	96 - 99	559 RSI	559 RSI
250	Pampera	02 - 13	774 HF	815 HF
250	Trial	89 - 96	559 RSI	559 RSI
250	Wild HP	08	671 SI*	671 SI
EC	250	97 - 99	671 SI	675 SI
EC	250	00 - 11	694 SI	604 SI
EC	250	12 - 18	694 SI	790 SI
EC	250 Enduro GP 18	18 -	694 SI	790 SI
EC	250 fse	02 - 11	694 SI	604 SI
GT	250 Contact	92 - 93	559 RSI	559 RSI
MC	250	97 - 99	671 RSI	675 RSI
MC	250	00 - 13	694 SI	604 SI
SM	250	02 - 13	566 HF	604 HF
TXT	250 (Formula cal.)	12 - 13	885 RSI	803 RSI
TXT	250	04 - 07	802 RSI	803 RSI
TXT	250 Pro Racing	14 - 18	939 RSI	803 RSI
TXT	250 Pro Replica	13 - 14	939 RSI	803 RSI
XC	250	17	694 SI	790 SI
TX	270	97 - 98	559 RSI	559 RSI
280	Pampera	04 - 08	774 HF	815 HF
TXT	280 (Formula cal.)	12	885 RSI	803 RSI
TXT	280	04	802 RSI	803 RSI
TXT	280 Pro Racing	14 - 18	939 RSI	803 RSI
TXT	280 Pro Replica	13	939 RSI	803 RSI
300	Wild HP	03 - 05	671 SI*	671 SI
EC	300	99	671 SI	675 SI
EC	300	00 - 11	694 SI	604 SI
EC	300	12 - 18	694 SI	790 SI
EC	300 Enduro GP 18	18 -	694 SI	790 SI
TXT	300 (Formula cal.)	12	885 RSI	803 RSI
TXT	300	04 - 06	802 RSI	803 RSI
TXT	300 Pro	07 - 11	802 RSI	803 RSI
TXT	300 Pro Racing	14 - 18	939 RSI	803 RSI
TXT	300 Pro Replica	13	939 RSI	803 RSI
XC	300	18 -	694 SI	790 SI
TX	320	97 - 99	559 RSI	559 RSI
325	Halley PXC	86	559 RSI	559 RSI
327	Trial	89 - 90	559 RSI	559 RSI
GT	327 Contact	89 - 90	559 RSI	559 RSI
370	Pampera	96 - 00	559 RSI	559 RSI
400	Pampera	06 - 09	694 SI	604 SI
EC	400 fse	02	694 SI	604 SI
SM	400 fse	02	566 HF	604 HF
450	Wild HP	03 - 09	671 SI*	671 SI

\* = 2 sets required / 2 jeux pour l'Avant.

Full compound selection, see under "Brake pad 1:1 Drawings" / Sélection complète de composés, voir "1:1 Schémas Plaquettes de frein".  
For ABE type approvals, see page 1 / Pour les homologations de type ABE, voir page 2.

**RECOMMENDED**1xx = Scooter Pads  
5xx = Street, Off Road & Racing Pads  
2xxx = Brake Shoes

GAS GAS				
EC	450 fse	03 - 15	694 SI	604 SI
EC	450 FSR	07 - 16	694 SI	604 SI
SM	450 fse	03 - 06	566 HF	604 HF
SM	450 FSR	07 - 13	566 HF	604 HF
	515 Wild HP	09	671 SI*	671 SI
EC	515 fsr	08 - 16	694 SI	604 SI
GILERA				
	50 Sioux	92	519 HF	519 HF
	80 TG 1, 2, 3	77 - 82	560 HF	
	125 Apache	91 - 94	608 HF	575 HF
	125 Arizona Hawk	86 - 89	519 HF	
	125 Crono	92 - 95	601 HF	519 HF
	125 Fast Bike	88 - 89	588 HF	
	125 Freestyle	92 - 95	601 HF	519 HF
	125 HX, HE	83	519 HF	
	125 KK, KR, KZ	86 - 91	588 HF	519 HF
	125 MX1, MRX, SP01	89 - 93	601 HF	519 HF
	125 R1, R1S	90 - 92	588 HF	519 HF
	125 SP02	90 - 94	601 HF	519 HF
	125 TG 1, 2, 3 (alu wheels)	77 - 85	560 HF	
	125 TG1, GR1, RTX	77 - 85	560 HF	
CX	125	91 - 95	601 HF	519 HF
ER	125 Rally	87	588 HF	
MXR	125	90	588 HF	519 HF
RC	125 Top Rally	90 - 93	608 HF	575 HF
RRT	125 Nebraska	87	588 HF	
RX	125 Arizona Hawk	85	588 HF	
	200 Arizona Hawk	85	588 HF	
	200 ER	87	588 HF	
	200 RX	83	519 HF	
RV	200	85 - 86	560 HF*	
	250 Arizona Hawk	86 - 91	519 HF	
	250 Arizona Rally	86 - 91	519 HF	
	250 Arizona Rally	08	588 HF	519 HF
NGR	250	85	574 HF*	519 HF
	350 Dakota	85	588 HF	
	350 Dakota	86 - 89	594 HF	
	350 Saturno Bialbero	90	566 HF	519 HF
XRT	350	90	588 HF	519 HF
	500 Dakota	86	588 HF	
	500 Saturno Bialbero	90	566 HF	519 HF
	500 Saturno Piuma	90 - 94	566 HF	519 HF
	600 Nordwest	91 - 94	601 HF*	519 HF
	600 Supersport	02	762 HS*	730 LS
RC	600	88	588 HF	519 HF
RC	600 Top Rally	90 - 94	608 HF	575 HF
XRT	600	89	588 HF	519 HF
GOES				
	360 Max	08 - 14	914 SI*	
	520 Max	07 - 12	914 SI*	799 SI
G	520	07 - 12	914 SI*	799 SI
G	525	12 - 14	914 SI*	799 SI
G	620	11 - 14	914 SI*	799 SI
G	625 A	12 - 14	914 SI*	799 SI
HARLEY DAVIDSON				
XG	500 Street	14 - 15	924 H.HF	924 H.HF
XG	500 Street	16 - 18	674 H.HF	671 H.HF
XG	750 Street	14 - 15	924 H.HF	924 H.HF
XG	750 Street	16 - 17	674 H.HF	671 H.HF
XG	750 Street Rod	18 -	674 H.HF*	671 H.HF
XL	883 C Sportster Custom	04 - 13	807 H.HS	808 H.LS
XL	883 L Sportster Low	06 - 13	807 H.HS	808 H.LS
XL	883 L Super Low	11 - 13	807 H.HS	808 H.LS
XL	883 L Super Low	14 - 18	934 H.HS	715 H.LS
XL	883 N Iron	13	807 H.HS	808 H.LS

**RECOMMENDED**1xx = Scooter Pads  
5xx = Street, Off Road & Racing Pads  
2xxx = Brake Shoes

HARLEY DAVIDSON				
XL	883 N Iron	14 - 18	934 H.HS	715 H.LS
XL	883 R Roadster	10 - 13	807 H.HS*	808 H.LS
XL	883 R Roadster	14 - 15	934 H.HS	715 H.LS
XL	883 R Sportster	00 - 03	826 H.HS	826 H.LS
XL	883 Series	74 - 77	679 H.HF	H.
XL	883 Sportster	04 - 13	807 H.HS	808 H.LS
XL	883 Sportster Custom	00 - 03	826 H.HS	826 H.LS
XL	883 Sportster R	05 - 13	807 H.HS*	808 H.LS
XLH	883	70 - 83	537 H.HF	H.
XLH	883 Series	88 - 99	579 H.HS*	669 H.LS
XLH	883 Sportster	85 - 86	579 H.HF	549 H.HF
XLH	883 Sportster	87 - 99	579 H.HF	669 H.HF
XLH	883 Sportster	00 - 03	826 H.HS	826 H.LS
XLH	883 Sportster Hugger	00 - 03	826 H.HS	826 H.LS
XL	1000	78	537 H.HF	543 H.HF
XLCH	1000	73	513 H.HF	H.
XLCH	1000	78 - 80	537 H.HF	543 H.HF
XLH	1000 Sportster	79 - 82	537 H.HF*	543 H.HF
XLH	1000 Sportster	83 - 85	537 H.HF*	549 H.HF
XLS	1000 Anniversary	82	537 H.HF*	549 H.HF
XLS	1000 Roadster	79 - 82	537 H.HF*	543 H.HF
XLS	1000 Sportster	83	537 H.HF*	549 H.HF
XLX	1000 61	83	537 H.HF*	549 H.HF
XLX	1000 61	84	537 H.HF	549 H.HF
XR	1000	85	537 H.HF*	549 H.HF
XLH	1100	87 - 88	579 H.HS	669 H.LS
XLH	1100 Sportster	85 - 86	579 H.HF	549 H.HF
XLX	1100	86	579 H.HF	549 H.HF
VRSCA	1130 V-Rod	02 - 05	826 H.HS*	826 H.LS
VRSCA	1130 V-Rod	06 - 10	830 H.HS*	830 H.LS
VRSCB	1130 V-Rod	04	826 H.HS*	826 H.LS
VRSCD	1130 Night Rod	06 - 08	830 H.HS*	830 H.LS
VRSCR	1130 Street Rod	06 - 07	830 H.HS*	830 H.LS
FL	1200 FLH Police	75 - 79	513 H.HF	513 H.HF
FLH	1200	74 - 76	513 H.HF	513 H.HF
FLH	1200	80	513 H.HF	553 H.HF
FLH	1200 Anniversary	78	513 H.HF	513 H.HF
FLH	1200 Touring	77 - 78	513 H.HF	513 H.HF
FLHS	1200	77 - 80	513 H.HF	513 H.HF
FX	1200	74 - 80	537 H.HF	513 H.HF
FXE	1200	74 - 80	537 H.HF	513 H.HF
FXS	1200	78 - 79	537 H.HF	513 H.HF
XL	1200 C Sportster Custom	04 - 13	807 H.HS	808 H.LS
XL	1200 C, CA, CB, CP Custom	14 - 18	934 H.HS	715 H.LS
XL	1200 CX	17	934 H.HS*	715 H.LS
XL	1200 L Sportster Low	07 - 10	807 H.HS	808 H.LS
XL	1200 N Nightster	07 - 12	807 H.HS	808 H.LS
XL	1200 R Sportster Roadster	04 - 09	807 H.HS*	808 H.LS
XL	1200 Roadster	18 -	934 H.HS*	715 H.LS
XL	1200 Sportster Custom	00 - 03	826 H.HS	826 H.LS
XL	1200 Sportster Sport	00 - 03	826 H.HS*	826 H.LS
XL	1200 T Super Low	15 - 17	934 H.HS	715 H.LS
XL	1200 V Seventy-Two	11 - 13	807 H.HS	808 H.LS
XL	1200 V Seventy-Two	14 - 16	934 H.HS	715 H.LS
XL	1200 X Forty-Eight	11 - 13	807 H.HS	808 H.LS
XL	1200 X Forty-Eight	14 - 18	934 H.HS	715 H.LS
XLH	1200 Sportster	90 - 99	579 H.HS	669 H.LS
XLH	1200 Sportster	00 - 03	826 H.HS	826 H.LS
XR	1200	08 - 10	860 H.HS*	808 H.LS
XR	1200 X	10 - 13	860 H.HS*	808 H.LS
VRSCAW	1250 V-Rod	08 - 10	830 H.HS*	830 H.LS
VRSCDX	1250 Night Rod Special	08 - 17	830 H.HS*	830 H.LS
VRSCF	1250 Muscle	09 - 17	830 H.HS	830 H.LS
VRSCX	1250 V-Rod	08 - 10	830 H.HS*	830 H.LS
FLH	1340 80	78 - 80	513 H.HF	513 H.HF
FLH	1340 80	81	513 H.HF	553 H.HF
FLH	1340 Classic	82 - 83	543 H.HF*	553 H.HF
FLH	1340 Electra Glide	82 - 83	543 H.HF*	513 H.HF

\* = 2 sets required / 2 jeux pour l'Avant.





**RECOMMENDED**

1xx = Scooter Pads  
 5xx = Street, Off Road & Racing Pads  
 2xxx = Brake Shoes



HARLEY DAVIDSON					
FLH	1340	Electra Glide Spec.	84	513 H.HF	553 H.HF
FLH	1340	Heritage	81	543 H.HF*	553 H.HF
FLHS	1340	Electra Glide Sport	90	579 H.HS*	668 H.LS
FLHT	1340	Electra Glide	85 - 86	579 H.HF*	549 H.HF
FLHT	1340	Electra Glide Classic	87 - 99	579 H.HS*	669 H.LS
FLHT	1340	Tour Glide	84	537 H.HF*	553 H.HF
FLHTC	1340	Electra Glide Classic	85 - 86	579 H.HF*	549 H.HF
FLHTC	1340	Electra Glide Classic	90 - 99	579 H.HS*	668 H.LS
FLHTC	1340	Electra Glide Classic	93	579 H.HS*	669 H.LS
FLHTC	1340	Ultra Classic	90 - 99	579 H.HS*	668 H.LS
FLST	1340	Heritage Softail	86 - 87	579 H.HF	549 H.HF
FLST	1340	Heritage Softail	88 - 99	579 H.HS	668 H.LS
FLSTC	1340	Heritage Softail Cl.	90 - 99	579 H.HS	669 H.LS
FLSTF	1340	Fat Boy	90 - 99	579 H.HS	669 H.LS
FLSTN	1340	Heritage Softail Nost.	93 - 99	579 H.HS*	669 H.LS
FLT	1340		84 - 85	579 H.HF	553 H.HF
FLT	1340	80	80 - 81	543 H.HF*	553 H.HF
FLT	1340	80 Classic	81	543 H.HF*	553 H.HF
FLT	1340	Classic	82 - 83	543 H.HF*	553 H.HF
FLT	1340	Tour Glide	82	543 H.HF*	553 H.HF
FLT/H	1340	Series	86 - 87	579 H.HS*	668 H.LS
FLTC	1340	Tour Glide Classic	85 - 86	579 H.HF	549 H.HF
FLTC	1340	Tour Glide Classic	90	579 H.HS*	668 H.LS
FXB	1340	80	80 - 81	537 H.HF	513 H.HF
FXB	1340	Sturgis	82	537 H.HF*	513 H.HF
FXDB	1340	Dyna Glide Daytona	91 - 99	579 H.HS*	669 H.LS
FXDB	1340	Dyna Glide Sturgis	91 - 99	579 H.HF	669 H.HF
FXDB	1340	Sturgis	91 - 99	579 H.HS	669 H.LS
FXDL	1340	Dyna Low Rider	93 - 99	579 H.HS*	669 H.LS
FXDWG	1340	Dyna Wide Glide	93 - 99	579 H.HS	669 H.LS
FXE	1340		82	537 H.HF	669 H.HF
FXE	1340		85 - 86	579 H.HF	549 H.HF
FXE	1340	80	78 - 81	537 H.HF	513 H.HF
FXE	1340	Super Glide	83 - 84	537 H.HF*	513 H.HF
FXEF	1340	80 Fat Bob	79 - 81	537 H.HF	513 H.HF
FXLR	1340	Low Rider Custom	87 - 88	579 H.HS	669 H.LS
FXLR	1340	Low Rider Custom	93 - 99	579 H.HS	669 H.LS
FXR	1340		78 - 81	537 H.HF	513 H.HF
FXR	1340		87 - 88	579 H.HS	669 H.LS
FXR	1340	Super Glide	82 - 83	537 H.HF	549 H.HF
FXR	1340	Super Glide	85 - 86	579 H.HF	549 H.HF
FXR	1340	Super Glide	90 - 99	579 H.HS	669 H.LS
FXRD	1340	Sport Glide GTE	85 - 86	579 H.HF*	549 H.HF
FXRS	1340	Low Glide	82 - 84	537 H.HF*	549 H.HF
FXRS	1340	Low Rider	85 - 86	579 H.HF*	549 H.HF
FXRS	1340	Low Rider Sport	87 - 99	579 H.HS*	669 H.LS
FXRS	1340	Low Rider Sport Ed.	90 - 99	579 H.HS*	669 H.LS
FXRS	1340	Low Rider, Convert.	90 - 99	579 H.HS*	669 H.LS
FXRS	1340	Super Glide II	82 - 83	537 H.HF*	549 H.HF
FXRT	1340	Sport Glide	85 - 86	579 H.HF*	549 H.HF
FXRT	1340	Sport Glide	90 - 99	579 H.HS*	669 H.LS
FXRT	1340	Super Glide II	83	537 H.HF	549 H.HF
FXS	1340	80	79 - 81	537 H.HF	513 H.HF
FXS	1340	Low Rider	82	537 H.HF*	513 H.HF
FXSB	1340	Low Rider	83	537 H.HF*	549 H.HF
FXST	1340	Softail	84 - 86	579 H.HF	549 H.HF
FXSTC	1340	Softail Custom	85 - 86	579 H.HF	549 H.HF
FXSTC	1340	Softail Custom	88 - 99	579 H.HS	669 H.LS
FXSTS	1340	Springer Softail	90 - 99	579 H.HS	669 H.LS
FXWG	1340		87 - 88	579 H.HS	669 H.LS
FXWG	1340	80	80 - 81	537 H.HF	513 H.HF
FXWG	1340	Wide Glide	82	537 H.HF*	513 H.HF
FXWG	1340	Wide Glide	83	537 H.HF*	549 H.HF
FXWG	1340	Wide Glide	84	537 H.HF	549 H.HF
FXWG	1340	Wide Glide	85 - 86	579 H.HF	549 H.HF
FLHR/I	1450	Road King	00 - 06	826 H.HS*	826 H.LS
FLHRCI	1450	Road King Classic	00 - 06	826 H.HS*	826 H.LS
FLHRS/I	1450	Road King Custom	04 - 06	826 H.HS*	826 H.LS



**RECOMMENDED**

1xx = Scooter Pads  
 5xx = Street, Off Road & Racing Pads  
 2xxx = Brake Shoes



HARLEY DAVIDSON					
FLHT/I	1450	Electra Glide Standard	00 - 06	826 H.HS*	826 H.LS
FLHTC/I	1450	Electra Glide Classic	00 - 06	826 H.HS*	826 H.LS
FLHTCUI	1450	Ultra Classic Electra			
		Glide	00 - 06	826 H.HS*	826 H.LS
FLHXI	1450	Street Glide	06	826 H.HS*	826 H.LS
FLSTC	1450	Softail	06 - 07	826 H.HS	826 H.LS
FLSTC/I	1450	Heritage Softail Classic	00 - 04	826 H.HS	826 H.LS
FLSTCI	1450	Softail	06	826 H.HS	826 H.LS
FLSTF	1450	Fat Boy	06 - 07	826 H.HS	826 H.LS
FLSTF/I	1450	Fat Boy	00 - 04	826 H.HS	826 H.LS
FLSTFI	1450	Fat Boy	06	826 H.HS	826 H.LS
FLSTI	1450	Heritage Softail	06	826 H.HS	846 H.LS
FLSTN/I	1450	Softail Deluxe	06	826 H.HS	826 H.LS
FLSTS/I	1450	Heritage Springer	00 - 03	579 H.HS	826 H.LS
FLSTSC/I	1450	Springer Softail Classic	06	579 H.HS	826 H.LS
FLT	1450	Series	88 - 99	579 H.HS*	668 H.LS
FLTR/I	1450	Road Glide Classic	00 - 06	826 H.HS*	826 H.LS
FXB	1450	Series	74 - 77	679 H.HF	H.
FXD	1450	Dyna Super Glide	00 - 03	826 H.HS	826 H.LS
FXDBI	1450	Dyna Street Bob	06	826 H.HS	826 H.LS
FXDC/I	1450	Dyna Super Glide			
		Custom	05 - 06	826 H.HS	826 H.LS
FXDI	1450	35th Anniversary			
		Super Glide	06	826 H.HS	846 H.LS
FXDI	1450	Dyna Super Glide	04 - 07	826 H.HS	826 H.LS
FXDL	1450	Dyna Low Rider	00 - 06	826 H.HS*	826 H.LS
FXDS	1450	Dyna Convertible	00 - 02	826 H.HS*	826 H.LS
FXDWG	1450	Dyna Wide Glide	00 - 03	826 H.HS	826 H.LS
FXDWGI	1450	Dyna Wide Glide	04 - 06	826 H.HS	826 H.LS
FXDX	1450	Dyna Super Glide			
		Sport	00 - 03	826 H.HS*	826 H.LS
FXDXI	1450	Dyna Super Glide			
		Sport	04 - 06	826 H.HS	826 H.LS
FXDXT	1450	Dyna Super Glide			
		T-Sport	00 - 03	826 H.HS*	826 H.LS
FXE	1450	Series	74 - 77	679 H.HF	513 H.HF
FXST/I	1450	Softail Standard	00 - 05	826 H.HS	826 H.LS
FXST/I	1450	Softail Standard	06	826 H.HS	846 H.LS
FXSTB/I	1450	Night Train	00 - 05	826 H.HS	826 H.LS
FXSTB/I	1450	Night Train	06	826 H.HS	846 H.LS
FXSTD/I	1450	Softail Deuce	00 - 05	826 H.HS	826 H.LS
FXSTD/I	1450	Softail Deuce	06	826 H.HS	846 H.LS
FXSTS/I	1450	Softail	05	579 H.HS	826 H.LS
FXSTS/I	1450	Softail	06	579 H.HS	846 H.LS
FXSTS/I	1450	Springer Softail	00 - 04	579 H.HS	826 H.LS
FLHR	1584	Road King	07	826 H.HS*	826 H.LS
FLHR	1584	Road King	08 - 10	830 H.HS*	830 H.LS
FLHRC	1584	Road King Classic	07	826 H.HS*	826 H.LS
FLHRC	1584	Road King Classic	08 - 10	830 H.HS*	830 H.LS
FLHRS	1584	Road King Custom	07	826 H.HS*	826 H.LS
FLHT	1584	Electra Glide Standard	07	826 H.HS*	826 H.LS
FLHT	1584	Electra Glide Standard	08 - 10	830 H.HS*	830 H.LS
FLHTC	1584	Electra Glide Classic	07	826 H.HS*	826 H.LS
FLHTC	1584	Electra Glide Classic	08 - 10	830 H.HS*	830 H.LS
FLHTCI	1584	Ultra Electra Glide			
		Classic	08 - 10	830 H.HS*	830 H.LS
FLHTCU	1584	Ultra Classic Electra			
		Glide	07 - 08	826 H.HS*	826 H.LS
FLHTCU	1584	Ultra Classic Electra			
		Glide	09 - 10	830 H.HS*	830 H.LS
FLHTK	1584	Electra Glide Ultra LTD	10	830 H.HS*	830 H.LS
FLHX	1584	Street Glide	07	826 H.HS*	826 H.LS
FLHX	1584	Street Glide	08 - 10	830 H.HS*	830 H.LS
FLSTC	1584	Heritage Softail Classic	07	826 H.HS	846 H.LS
FLSTC	1584	Heritage Softail Classic	08 - 11	853 H.HS	854 H.LS
FLSTF	1584	Fat Boy	07	826 H.HS	846 H.LS
FLSTF	1584	Fat Boy	08 - 11	853 H.HS	854 H.LS
FLSTFB	1584	Fat Boy Special	10 - 11	853 H.HS	854 H.LS

\* = 2 sets required / 2 jeux pour l'Avant.

Full compound selection, see under "Brake pad 1:1 Drawings" / Sélection complète de composés, voir "1:1 Schémas Plaquettes de frein".  
 For ABE type approvals, see page 1 / Pour les homologations de type ABE, voir page 2.

Applications  
 Motorcycles, Off Road, ATV/UTV, Scooters

**RECOMMENDED**

1xx = Scooter Pads  
5xx = Street, Off Road & Racing Pads  
2xxx = Brake Shoes

**HARLEY DAVIDSON**

FLSTN	1584	Softail Deluxe	07	826 H.HS	846 H.LS
FLSTN	1584	Softail Deluxe	08 - 11	853 H.HS	854 H.LS
FLSTSC/I	1584	Softail	07	579 H.HS	846 H.LS
FLTR	1584	Road Glide	08 - 10	830 H.HS*	830 H.LS
FLTRU	1584	Road Glide Ultra	11 - 16	830 H.HS*	830 H.LS
FLTRX	1584	Road Glide Custom	10	830 H.HS*	830 H.LS
FXCW	1584	Rocker	08 - 09	853 H.HS	854 H.LS
FXCWC	1584	Rocker C	08 - 13	853 H.HS	854 H.LS
FXD	1584	Dyna Super Glide	07	826 H.HS	826 H.LS
FXD	1584	Dyna Super Glide	08 - 10	853 H.HS	854 H.LS
FXDB	1584	Dyna Street Bob	07	826 H.HS	826 H.LS
FXDB	1584	Dyna Street Bob	08 - 13	853 H.HS	854 H.LS
FXDC	1584	Dyna Super Glide			
		Custom	07	826 H.HS	826 H.LS
FXDC	1584	Dyna Super Glide			
		Custom	08 - 13	853 H.HS	854 H.LS
FXDF	1584	Fat Bob	08 - 11	853 H.HS	854 H.LS
FXDL	1584	Dyna Low Rider	07	826 H.HS	826 H.LS
FXDL	1584	Dyna Low Rider	08 - 13	853 H.HS	854 H.LS
FXDWG	1584	Dyna Wide Glide	07	826 H.HS	826 H.LS
FXDWG	1584	Dyna Wide Glide	08 - 10	853 H.HS	854 H.LS
FXST	1584	Softail Standard	07	826 H.HS	846 H.LS
FXST	1584	Softail Standard	08 - 14	853 H.HS	854 H.LS
FXST	1584	Softail Standard	15 - 17	860 H.HS	854 H.LS
FXSTB	1584	Night Train	07	826 H.HS	846 H.LS
FXSTB	1584	Night Train	08 - 09	853 H.HS	854 H.LS
FXSTC	1584	Softail Custom	07	826 H.HS	846 H.LS
FXSTC	1584	Softail Custom	08 - 10	853 H.HS	854 H.LS
FXSTD	1584	Softail Deuce	07	826 H.HS	846 H.LS
FLD	1690	Switchback	12 - 16	853 H.HS	854 H.LS
FLHR	1690	Road King	11 - 16	830 H.HS*	830 H.LS
FLHRC	1690	Road King Classic	11 - 16	853 H.HS	854 H.LS
FLHTC	1690	Electra Glide Classic	11 - 16	853 H.HS	854 H.LS
FLHTCU	1690	Ultra Classic Electra			
		Glide	11 - 16	830 H.HS*	830 H.LS
FLHTCUL	1690	Electra Glide Ultra			
		Classic Low	15 - 16	830 H.HS*	830 H.LS
FLHTCUTG	1690	Tri Glide Ultra	14 - 16	922 H.HS*	923 H.LS
FLHTCUTG	1690	Tri Glide Ultra			
		Classic Trike	09 - 13	830 H.HS*	904 H.LS
FLHTK	1690	Ultra Classic Electra			
		Glide	10 - 16	830 H.HS*	830 H.LS
FLHTK	1690	Ultra Electra Glide	11 - 16	853 H.HS	854 H.LS
FLHTKL	1690	Ultra Limited Low	15 - 16	830 H.HS*	830 H.LS
FLHX	1690	Street Glide	11 - 16	830 H.HS*	830 H.LS
FLHXS	1690	Street Glide Special	14 - 16	830 H.HS*	830 H.LS
FLHXXX	1690	Street Glide Trike	10 - 11	830 H.HS*	904 H.LS
FLRT	1690	Freewheeler	15 - 16	922 H.HS*	923 H.LS
FLS	1690	Softail Slim	12 - 14	853 H.HS	854 H.LS
FLS	1690	Softail Slim	15 - 17	860 H.HS	854 H.LS
FLSTC	1690	Heritage Softail			
		Classic	12 - 14	853 H.HS	854 H.LS
FLSTC	1690	Heritage Softail			
		Classic	15 - 17	860 H.HS	854 H.LS
FLSTF	1690	Fat Boy	12 - 14	853 H.HS	854 H.LS
FLSTF	1690	Fat Boy	15 - 17	860 H.HS	854 H.LS
FLSTF	1690	Fat Boy Special	12 - 14	853 H.HS	854 H.LS
FLSTFB	1690	Fat Boy	12 - 14	853 H.HS	854 H.LS
FLSTFB	1690	Fat Boy	15 - 17	860 H.HS	854 H.LS
FLSTN	1690	Softail Deluxe	12 - 14	853 H.HS	854 H.LS
FLSTN	1690	Softail Deluxe	15 - 17	860 H.HS	854 H.LS
FLTRX	1690	Road Glide	15 - 16	830 H.HS*	830 H.LS
FLTRXS	1690	Road Glide Special	15 - 16	830 H.HS*	830 H.LS
FXDB	1690	Dyna Street Bob	14 - 17	853 H.HS	854 H.LS
FXDBA	1690	Dyna Street Bob	13 - 17	853 H.HS	854 H.LS
FXDBB	1690	Dyna Street Bob	14 - 17	853 H.HS	854 H.LS
FXDBP	1690	Dyna Street Bob	13 - 17	853 H.HS	854 H.LS

**RECOMMENDED**

1xx = Scooter Pads  
5xx = Street, Off Road & Racing Pads  
2xxx = Brake Shoes

**HARLEY DAVIDSON**

FXDC	1690	Dyna Super Glide			
		Custom	14	853 H.HS	854 H.LS
FXDF	1690	Dyna Wide Glide	12 - 17	853 H.HS	854 H.LS
FXDF	1690	Fat Bob	12 - 17	853 H.HS*	854 H.LS
FXDL	1690	Dyna Low Rider	14 - 17	853 H.HS*	854 H.LS
FXDLS	1690	Dyna Low Rider S	17	853 H.HS*	854 H.LS
FXS	1690	Blackline	13 - 17	853 H.HS	854 H.LS
FXSB	1690	Breakout	14	853 H.HS	854 H.LS
FXSB	1690	Breakout	15 - 17	860 H.HS	854 H.LS
FLDE	1750	Softail Deluxe	18 -	860 H.HS	949 H.LS
FLFB	1750	Fat Boy	18 -	860 H.HS	949 H.LS
FLHC	1750	Heritage Classic	18 -	860 H.HS	949 H.LS
FLHR	1750	Road King	17 - 18	830 H.HS*	830 H.LS
FLHRC	1750	Road King Classic	17	830 H.HS*	830 H.LS
FLHRXS	1750	Road King Special	18 -	830 H.HS	949 H.LS
FLHTCU	1750	Ultra Classic Electra			
		Glide	17 - 18	830 H.HS*	830 H.LS
FLHTCUTG	1750	Tri Glide Ultra	17 - 18	922 H.HS*	923 H.LS
FLHTK	1750	Ultra Limited	17 - 18	830 H.HS*	830 H.LS
FLHTKL	1750	Ultra Limited Low	17 - 18	830 H.HS*	830 H.LS
FLHX	1750	Street Glide	17 - 18	830 H.HS*	830 H.LS
FLHX	1750	Street Glide Special	17 - 18	830 H.HS*	830 H.LS
FLHXS	1750	Street Glide Special	17 - 18	830 H.HS*	830 H.LS
FLRT	1750	Freewheeler	17 - 18	922 H.HS*	923 H.LS
FLSL	1750	Softail Slim	18 -	860 H.HS	949 H.LS
FLTRU	1750	Road Glide Ultra	17 - 18	830 H.HS*	830 H.LS
FLTRX	1750	Road Glide	17 - 18	830 H.HS*	830 H.LS
FLTRXS	1750	Road Glide Special	17 - 18	830 H.HS*	830 H.LS
FXBB	1750	Street Bob	18 -	860 H.HS	949 H.LS
FXBR	1750	Breakout	18 -	860 H.HS	949 H.LS
FXFB	1750	Fat Bob	18 -	860 H.HS	949 H.LS
FXLR	1750	Low Rider	18 -	860 H.HS	949 H.LS
FLHRSE5	1802	CVO Road King	14 - 15	830 H.HS*	830 H.LS
FLHTKSE	1802	CVO Limited	14 - 16	830 H.HS*	830 H.LS
FLHXSE	1802	CVO Street Glide	10 - 16	830 H.HS*	830 H.LS
FLSS	1802	Softail Slim S	16 - 17	860 H.HS	854 H.LS
FLSTFBS	1802	Fat Boy S	16 - 17	860 H.HS	854 H.LS
FLSTNSE	1802	CVO Softail Deluxe	14	853 H.HS*	854 H.LS
FLSTNSE	1802	CVO Softail Deluxe	15 - 17	860 H.HS*	854 H.LS
FLTRUSE	1802	CVO Road Glide			
		Ultra	11 - 16	830 H.HS	830 H.LS
FXSBSE	1802	CVO Breakout	13 - 14	853 H.HS	854 H.LS
FLFBS	1870	Fat Boy	18 -	860 H.HS	949 H.LS
FLHCS	1870	Heritage Classic	18 -	860 H.HS	949 H.LS
FLHTKSE	1870	CVO Limited	17	830 H.HS*	830 H.LS
FLHXSE	1870	CVO Street Glide	17	830 H.HS*	830 H.LS
FXBRS	1870	Breakout	18 -	860 H.HS	949 H.LS
FLHTKSE	1917	CVO Limited	18 -	830 H.HS*	830 H.LS
FLHXSE	1917	CVO Street Glide	18 -	830 H.HS*	830 H.LS
FLTRXSE	1917	CVO Road Glide	18 -	830 H.HS*	830 H.LS

**HIGHLAND**

	450 MX	06 - 09	671 RSI	675 RSI
	950 V2 Motard	00 - 08	671 HF	675 HF
	950 V2 Outback	99 - 08	671 HF	675 HF

**HISUN**

HS	400 UTV Left/Rear	15 - 17	638 SI	767 SI
HS	400 UTV Right	15 - 17	611 SI	
HS	500 UTV Left/Rear	15 - 17	638 SI	767 SI
HS	500 UTV Right	15 - 17	611 SI	
HS	700 UTV Left (2 cal.rear)	15 - 17	638 SI	638 SI
HS	700 UTV Left/Rear	15 - 17	638 SI	767 SI
HS	700 UTV Right	15 - 17	611 SI	
HS	700 UTV Right (2 cal.rear)	15 - 17	611 SI	611 SI
HS	800 UTV Left (2 cal.rear)	15 - 17	638 SI	638 SI
HS	800 UTV Right (2 cal.rear)	15 - 17	611 SI	611 SI

\* = 2 sets required / 2 jeux pour l'Avant.





**RECOMMENDED**

1xx = Scooter Pads  
5xx = Street, Off Road & Racing Pads  
2xxx = Brake Shoes



HONDA					
CB	50 all models	80 - 81	100 HF	2013	
CH	50 P Metropolitan II	02 - 06	2057	2057	
CHF	50 Metropolitan	02 - 05	2057	2057	
CR	50 RE, RF	84 - 85	2057	2057	
CRF	50 F	04 - 18	2010	2010	
MB	50 S	80 - 82	100 HF	2013	
MBX	50	80 - 82	100 HF	2013	
MT	50 S	80 - 93	2013	2013	
NA	50 Express	79 - 81	2010	2011	
NB	50 ME, Aero	83 - 87	2010	2011	
NC	50 Express	77 - 80	2010	2010	
NC	50 Express	81 - 83	2010	2011	
NH	50 Lead	83	2012	2011	
NH	50 Lead	86 - 93	110 HF	2011	
NH	50 Lead	94	121 HF	2011	
NH	50 Lead (Drum vers.)	94	2012	2011	
NH	50 Lead SS,MR,MSE	84 - 85	112 HF	2011	
NN	50 MD Gyro	84	2010	2010	
NPS	50 Zoomer	01 - 12	2057	2057	
NQ	50 D, Spree	84 - 87	2010	2010	
NS-1	50	91 - 94	103 HF	2011	
NSC	50 Vision	10 - 18	205 HF		
NSR	50	89 - 90	103 HF	2013	
PA	50	78 - 81	2010	2074	
PA	50	82 - 83	2010	2010	
PK	50 Walaroo DX-STD	90 - 01	2057	2012	
PX	50	82 - 83	2074	2011	
QA	50 K1-K3	87 - 89	2074	2074	
QR	50	93 - 03	2010	2057	
QR	50 ED, EF	82 - 92	2010	2011	
R	50 Monkey	88	618 HF	2012	
SA	50 Elite LX, SR	88 - 93	2010	2011	
SA	50 J Vision	88 - 94	2057	2057	
SB	50	88 - 89	2010	2010	
TG	50 M Gyro S	85 - 86	2010	2010	
XR	50 R	00 - 03	2010	2010	
Z	50 R, RD	80 - 99	2010	2010	
CR	60 RF, RG	85 - 86	2057	2057	
ATC	70 all models	78 - 85		2069	
ATC	70 K1	76 - 77		2012	
C	70 all models	75 - 83	2012	2012	
CRF	70 F	04 - 14	2057	2057	
CT	70	91 - 94	2010	2010	
TRX	70	86 - 87	2048	2041	
XR	70	97 - 12	2057	2057	
NS-1	75	92 - 00	119 HF	121 HF	
ATC	80	76 - 78		2019	
CB	80	80 - 81	100 HF		
CH	80 Elite	85 - 88	2012	2057	
CR	80 R	86 - 91	584 SI	2043	
CR	80 R, RB	92 - 02	584 RSI	604 RSI	
CR	80 R2	85	2013	2013	
CR	80 RA, RB	80 - 81	2013	2013	
CR	80 RC	82	2013	2057	
CR	80 RD, RE	83 - 84	2057	2057	
CR	80 RF	85	2057	2043	
CRF	80 F	04 - 14	2057	2057	
NH	80 Aero	85	2012	2057	
NH	80 MD Lead, Aero	83 - 84	2012	2011	
NSR	80 R	87 - 92	103 HF	121 HF	
NSR	80 R	93 - 95	119 HF	121 HF	
XR	80	79 - 84	2013	2013	
XR	80 R	85 - 88	2057	2057	
CR	85 R, R Expert	03 - 12	592 RSI	604 RSI	
ATC	90 K1, K2, K3	73 - 78		2019	
C	90	93 - 02	2013	2013	
EZ	90 Cub	90 - 95	2012	2012	
NH	90 Yupy	90 - 94	121 HF	2013	



**RECOMMENDED**

1xx = Scooter Pads  
5xx = Street, Off Road & Racing Pads  
2xxx = Brake Shoes



HONDA					
TRX	90	93 - 01	2012		2019
	100 Lead	00 - 08	104 HF		
CRF	100 F	04 - 14	2057	2057	
NSF	100	06	688 RS	604 HF	
XL	100 all models	78 - 85	2013	2013	
XR	100	81 - 84	2013	2013	
XR	100 R	85 - 03	2057	2057	
AFS	110 Wave	12 - 18	216 HF		
ATC	110 all models	79 - 85			2019
CRF	110 F	13 - 18	2057	2057	
NHX	110	08 - 09	125 HF		
NHX	110	10 - 12	104 CT		
NSC	110 Vision	10 - 12	205 HF		
	125 Grom	14 - 17	797 HF	915 HF	
ANF	125 i Innova	07 - 11	180 CT	2012	
ANF	125 Innova	03 - 06	180 CT	2012	
ATC	125 ME, MF, MG, MH	84 - 87	2012	2019	
CB	125 S	79 - 82	2013	2013	
CB	125 S	84 - 85	2041	2012	
CBR	125 R	03 - 10	797 HF	784 HF	
CBR	125 R	11 - 18	797 HF	915 HF	
CH	125 D, E, Spacy, Elite	83 - 84	2012	2012	
CR	125 M2, M3, M4	76 - 78	2013	2013	
CR	125 R	79 - 81	2031	2041	
CR	125 R	95 - 01	694 RSI	604 RSI	
CR	125 R	02 - 07	694 RSI	777 RSI	
CR	125 RC	82	2041	2041	
CR	125 RD	83	2042	2042	
CR	125 RE, RF	84 - 85	558 SI	2042	
CR	125 RG	86	558 SI	2047	
CR	125 RH, RJ, RK	87 - 94	603 RSI	604 RSI	
CRE	125	02 - 07	694 SI	777 SI	
CRE	125 RR	11	859 SI	777 SI	
CRF	125 F	14 - 18	694 SI	2057	
MT	125 R	77	525 HF	2013	
MT	125 R	78	517 HF	2013	
NES	125 @	01 - 06	104 CT	2208	
NH	125 Lead Scooter	86 - 87	112 CT	2012	
NSS	125 Forza	15 - 18	183 CT	193 CT	
PCX	125	09 - 18	205 MS	2208	
PS	125 i	07 - 13	125 CT	2208	
RS	125	95 - 03	566 DC	618 RQ	
RS	125 R	91 - 94	627 HF*	618 HF	
SES	125 Dylan	02 - 07	125 CT	2208	
SH	125	02 - 08	125 CT	2208	
SH	125	13 - 18	183 CT	193 HF	
SH	125 i	09 - 12	192 HF	193 HF	
TRX	125	85 - 88	2012	2019	
XL	125 K2	78	2013	2013	
XL	125 K3	79	2012	2013	
XL	125 S	79 - 84	2013	2013	
XLR	125 R	98 - 01	694 HF	2013	
XR	125 L	03 - 07	694 HF	2013	
CBR	150 R	00 - 10	797 HF	784 HF	
CH	150 D Elite	85 - 87	2012	2012	
CRF	150 F	03 - 06	694 SI	2013	
CRF	150 R	07 - 18	592 RSI	777 RSI	
NES	150 @	01 - 06	104 CT	2208	
NS	150	92 - 95	121 HF		
NSR	150	02	688 HF	611 HF	
PCX	150	12 - 18	205 MS	2208	
PS	150 i	07 - 11	125 CT	2208	
SES	150 Dylan	02 - 06	125 CT	2208	
SH	150	02 - 08	125 CT	2208	
SH	150	13 - 18	183 CT	193 HF	
SH	150 i	09 - 12	192 HF	193 HF	
CB	175 K3-K7	74 - 76		2068	
CD	175 all models	71 - 78	2019		

\* = 2 sets required / 2 jeux pour l'Avant.

Full compound selection, see under "Brake pad 1:1 Drawings" / Sélection complète de composés, voir "1:1 Schémas Plaquettes de frein".  
For ABE type approvals, see page 1 / Pour les homologations de type ABE, voir page 2.

**RECOMMENDED**1xx = Scooter Pads  
5xx = Street, Off Road & Racing Pads  
2xxx = Brake Shoes

HONDA				
ATC	185 A, S, SB	80 - 83	2012	2019
CM	185 T	78 - 79	2023	2069
XL	185 S	79 - 83	2013	2013
ATC	200	81 - 83	2012	2019
ATC	200 E Big Red	82 - 83	2012	2019
ATC	200 ES Big Red	84	2012	2019
ATC	200 M	84 - 85	2012	2019
ATC	200 S	84 - 86	2012	2019
ATC	200 X	83 - 85	592 SI	562 SI
ATC	200 X	86 - 87	592 SI	592 SI
CM	200 TA, TB	80 - 82	2023	2069
CTX	200	04 - 06	694 SI	2013
TLR	200 Fatcat	86 - 87	2013	2013
TLR	200 G, H	86 - 87	2013	2057
TR	200	86 - 87	2013	2013
TRX	200	84	2044	2019
TRX	200	90 - 91	2083	2019
TRX	200 D Type II	91 - 97	2083	2019
TRX	200 SX	86 - 88	2083	2019
XL	200 R	83 - 84	2013	2013
XR	200	80 - 84	2013	2013
XR	200 R	84 - 02	2013	2013
XR	200 R, Pro Link	81 - 83	2013	2013
CRF	230	04 - 09	694 SI	2013
CRF	230 L	08 - 10	694 SI	604 SI
CRF	230 M	09 - 12	694 SI	604 SI
SL	230	97 - 01	694 HF	604 HF
	250 Cota 4RT	04 - 16	802 RSI	803 RSI
ATC	250 ES, SX	85 - 87	2019	2024
ATC	250 R	81	536 SI	2014
ATC	250 R	82 - 84	584 SI	562 SI
ATC	250 R	85 - 86	558 SI	558 SI
ATC	250 X	85	558 SI	562 SI
CA	250 Rebel	90 - 95	638 HF	2058
CB	250 Nighthawk	91 - 02	2023	2069
CBF	250	04 - 08	688 HF	
CBR	250 R (Bybre cal)	11	674 HS	675 LS
CBR	250 R (Nissin cal)	11 - 13	627 HS	881 LS
CBR	250 R ABS (Nissin cal)	11 - 13	828 HS	881 LS
CBR	250 RR	17 - 18	700 HS	881 LS
CH	250 Elite	85 - 86	2041	2082
CH	250 Elite	87 - 90	2041	2041
CM	250 C	82 - 83	2023	2069
CMX	250 C Rebel	96 - 00	713 HF	2069
CMX	250 Rebel	85 - 12	551 HF	2069
CN	250	93 - 04	127 CT	2041
CN	250 Helix	86 - 87	160 CT	2189
CR	250 R	81 - 82	2030	2041
CR	250 R	83		2042
CR	250 R	87 - 94	603 RSI	604 RSI
CR	250 R	95 - 01	694 RSI	604 RSI
CR	250 R	02 - 07	694 RSI	777 RSI
CR	250 RE, RF	84 - 85	558 SI	2042
CR	250 RG	86	558 SI	2047
CR	250 RZ, RA	79 - 80	2031	2075
CRE	250	02 - 07	694 SI	777 SI
CRF	250 L	13 - 15	859 SI	915 SI
CRF	250 L ABS	17 - 18	859 SI	915 SI
CRF	250 M	14 - 18	859 SI	915 SI
CRF	250 R	04 - 09	694 RSI	777 RSI
CRF	250 R Efi	10 - 17	694 RSI	777 RSI
CRF	250 R Efi	18 -	694 RSI	777 RSI
CRF	250 Rally	17 - 18	859 SI	915 SI
CRF	250 X	04 - 14	694 SI	777 SI
FL	250 Odyssey	77 - 84	525 HF	2019
FL	250 Odyssey	84	529 HF	2019
MT	250 K1	74 - 76	2023	2023
MTX	250 R	86	558 SI	

**RECOMMENDED**1xx = Scooter Pads  
5xx = Street, Off Road & Racing Pads  
2xxx = Brake Shoes

HONDA				
NSS	250 Reflex	01 - 07	156 MS	158 MS
NX	250	88 - 90	603 HF	2029
PS	250	05 - 06	192 MS	
RS	250 R	91 - 92	622 DC*	614 HF
RS	250 R	93	566 DC*	618 RQ
TL	250	75 - 76	2013	2013
TRX	250	85 - 87	2044	2024
TRX	250 EX Sportrax	01 - 08	592 SI*	2055
TRX	250 R	86 - 89	603 SI*	558 SI
TRX	250 R Fourtrax	88	603 SI*	558 SI
TRX	250 Recon	97 - 14	2083	2055
TRX	250 X	08 - 13	592 SI*	2055
TRX	250 X Fourtrax	87	603 SI*	558 SI
TRX	250 X Fourtrax	88 - 92	584 SI*	584 SI
VTR	250	88 - 89	552 HF	2068
VTR	250	90	593 HS	2068
VTR	250	98 - 02	654 HF	614 HF
XL	250	78 - 79	2070	2023
XL	250 R	82 - 83	2041	2029
XL	250 R	84 - 87	558 HF	2013
XL	250 S	78 - 80	2023	2029
XL	250 S	81	2023	2026
XR	250	79 - 80	2023	2029
XR	250 L	91 - 92	603 HF	604 HF
XR	250 L	93 - 97	694 HF	604 HF
XR	250 R	81 - 83	2030	2029
XR	250 R	84 - 87	558 SI	2013
XR	250 R	88 - 89	603 SI	2013
XR	250 R	90 - 95	603 SI	604 SI
XR	250 S, R	96 - 00	694 HF	604 HF
Cota	260 4Ride	16 - 18	939 RSI	803 RSI
Cota	260 4RT	04 - 16	802 RSI	803 RSI
Cota	260 4RT Race Replica	15 - 18	939 RSI	803 RSI
CB	300	10	688 HF	
CBR	300 F	14 - 16	700 HS	881 LS
CBR	300 F ABS	14 - 17	700 HS	881 LS
CBR	300 R	14 - 18	700 HS	881 LS
CMX	300 Rebel	17 - 18	700 HS	881 LS
Cota	300 RR	16 - 18	939 RSI	803 RSI
SH	300 i	07 - 18	192 MS	193 HF
SH	300 i SH30	15 - 18	183 MS	193 MS
TRX	300	88 - 00		2024
TRX	300 4WD	88 - 00	2085	2024
TRX	300 EX	93 - 00	592 SI*	562 SI
TRX	300 EX Sportrax	01 - 08	592 SI*	592 SI
TRX	300 X	09	592 SI*	592 SI
ATC	350 Odyssey	85	558 SI	562 SI
ATC	350 X	85	558 SI	562 SI
ATC	350 X	86 - 89	603 SI	562 SI
CB	350 F, F1	73 - 76	501 HF	2024
CB	350 K4	74	2071	2024
FL	350 R Odyssey	85 - 87	2044	610 HF
TRX	350 all models	86 - 89	2045	2046
TRX	350 Rancher /ES 2x4, 4x4	00 - 09	2085	2207
XL	350	76 - 78	2070	2023
XL	350 R	84 - 87	558 HF	2029
XR	350 R	83	2042	2013
XR	350 R	84 - 85	558 SI	2013
CB	360 G, T	73 - 76	501 HF	2024
CB	400	81 - 82	542 HF	542 HF
CB	400 A	77 - 81	526 HF	2058
CB	400 F, F1, F2	75 - 79	501 HF	2024
CB	400 Hawk	81 - 85	542 HF	542 HF
CB	400 N, T, Hawk	78 - 82	526 HF	2058
CB	400 T1, T2	77 - 78	526 HF	2058
CB-1	400 (CB 400 F)	89 - 90	627 HS	614 LS
CM	400 A, T, TZ	79	526 HF	2058
CM	400 C	81	572 HF	2058

\* = 2 sets required / 2 jeux pour l'Avant.





**RECOMMENDED**

1xx = Scooter Pads  
5xx = Street, Off Road & Racing Pads  
2xxx = Brake Shoes



HONDA				
CM	400 E	80 - 81	2071	2058
CM	400 T	79 - 81	526 HF	2058
FJS	400 Silverwing	06 - 08	156 MS	184 MS
FJS	400 Silverwing (Parking Brake)	06 - 08		209 HF
FL	400 R Pilot	89 - 90	2044	610 HF
RVF	400 RR (NC35)	90 - 96	622 HF*	623 HF
SW-T	400	09 - 13	192 MS	184 MS
SW-T	400 ABS	09 - 14	192 MS	184 MS
TRX	400 AT	04 - 11	2085	2207
TRX	400 EX Sportrax	01 - 08	592 SI*	592 SI
TRX	400 Fourtrax EX	99 - 00	592 SI*	592 SI
TRX	400 FW Fourtrax Foreman	95 - 02	2085	2207
TRX	400 X	09 - 12	592 SI*	592 SI
XR	400 R	96 - 04	694 SI	604 SI
TRX	420 FA / FPA	09 - 13	592 SI*	813 SI
TRX	420 FPE / FPM 4x4	09 - 14	592 SI*	
XR	440 R	00 - 03	694 SI	604 SI
CB	450 K5, K6, K7	72 - 77	501 HF	2072
CB	450 SC Nighthawk	82	561 HF	2058
CB	450 SC Nighthawk	83 - 86	572 HF	2058
CM	450 A, C	82 - 86	542 HF	2058
CMX	450 Rebel	86 - 88	542 HF	2058
CR	450 R	81	2030	
CRE	450 F	02 - 06	694 SI	777 SI
CRF	450 Efi	09 - 12	694 RSI	777 RSI
CRF	450 R	02 - 08	694 RSI	777 RSI
CRF	450 R Efi	13 - 18	694 RSI	777 RSI
CRF	450 RX Efi	17 - 18	694 SI	777 SI
CRF	450 X	05 - 18	694 SI	777 SI
TRX	450 EX Sportrax	01 - 05	592 SI*	592 SI
TRX	450 Foreman ES, Foreman S	98 - 04	2085	2207
TRX	450 R	04 - 09	694 SI*	813 SI
CR	480 R	82	2030	2041
CR	480 R	83		2042
CB	500 F	72 - 75	501 HF	2072
CB	500 F	13 - 18	700 HS	881 LS
CB	500 T	75 - 78	501 HF	2072
CB	500 X	13 - 18	700 HS	881 LS
CBR	500 R	13 - 18	700 HS	881 LS
CMX	500 Rebel	17 - 18	700 HS	881 LS
CR	500 R	87 - 94	603 RSI	604 RSI
CR	500 R	95 - 01	694 RSI	604 RSI
CR	500 RE, RF	84 - 85	558 SI	2042
CR	500 RG	86	558 SI	2047
CX	500	78 - 80	517 HF*	2059
CX	500	81	572 HF*	
CX	500 C	81 - 82	542 HF*	2059
CX	500 Silver W., Turbo	83 - 85	542 HF*	542 HF
CX	500 Turbo	82 - 83	542 HF*	572 HF
CX	500 Z, A, B	79 - 81		2059
FT	500	82 - 84	542 HF*	542 HF
GB	500 T.T.	88 - 92	542 HF	2059
GL	500	82	572 HF*	542 HF
GL	500 D	81 - 82	542 HF*	2059
GL	500 I	81 - 82	572 HF*	2059
TRX	500 all models	05 - 14	829 SI*	2046
TRX	500 Foreman, Rubicon	00 - 09	2085	2072
VF	500 F, FI	84 - 86	542 HF*	542 HF
VT	500 C Shadow	83 - 86	542 HF	2058
VT	500 ED	82	552 HF	2058
XL	500 R	83 - 87	558 HF	2026
XL	500 RC	82	2077	2026
XL	500 SB	81	2075	2068
XL	500 SZ	80	2023	2026
XR	500 R Pro Link	81 - 82	2030	2026
XR	500 R, Pro Link	83 - 84	558 HF	2013



**RECOMMENDED**

1xx = Scooter Pads  
5xx = Street, Off Road & Racing Pads  
2xxx = Brake Shoes



HONDA				
XR	500 SZ, SA	79 - 80	2031	2026
CB	550 F	75 - 79	501 HF	2072
CB	550 K	74 - 78	501 HF	2072
CB	550 SC	83 - 84	542 HF	2058
CBX	550 F, F2	82 - 86	552 HF*	571 HF
CB	599	04	627 HS*	657 LS
CB	600 Hornet	07 - 12	627 HS*	834 LS
CB	600 Hornet ABS	07 - 12	828 HS*	657 LS
CBR	600 F	11 - 13	627 HS*	834 LS
CBR	600 F ABS	11 - 13	828 HS*	657 LS
CBR	600 F Hurricane	87 - 90	593 HS*	542 LS
CBR	600 F, Super Sport	91 - 94	593 HS*	657 LS
CBR	600 F3	95 - 98	627 HS*	657 LS
CBR	600 F4, F4 Sport	99 - 06	734 HS*	657 LS
CBR	600 RR	03 - 04	734 HS*	657 LS
CBR	600 RR	05 - 06	809 HS*	657 LS
CBR	600 RR	07 - 08	809 HS*	834 LS
CBR	600 RR ABS	09 - 18	809 HS*	834 LS
FSC	600 Silverwing	01 - 08	156 MS	184 MS
FSC	600 Silverwing	09 - 18	192 MS	184 MS
	(Parking Brake)	01 - 18		209 HF
SW-T	600	11 - 13	192 MS	184 MS
VT	600 C, Shadow	88 - 93	647 HS	2059
VT	600 C, Shadow	94 - 00	627 HS	2059
VT	600 CD Shadow VLX	94 - 00	627 HS*	2059
XL	600 R	83 - 86	558 HF	2026
XL	600 V, Transalp	87 - 90	542 HS	2026
XR	600 R	83 - 87	558 SI	2013
XR	600 R	88 - 90	603 SI	2013
XR	600 R	91 - 92	603 SI	604 SI
XR	600 R	93 - 00	694 SI	604 SI
CB	650	79 - 81	526 HF	2027
CB	650	85	542 HF*	
CB	650 C	80 - 85	526 HF	2027
CB	650 F	14 - 18	700 HS*	881 LS
CB	650 SC Nighthawk	83 - 85	542 HF*	2059
CB	650 SCC Nighthawk	82	561 HF*	2027
CB	650 Z	78 - 81	526 HF*	2027
CBR	650 F	14 - 18	700 HS*	881 LS
CBR	650 F ABS	14 - 18	700 HS*	881 LS
CX	650 C	83 - 86	542 HF*	2059
CX	650 E	83 - 86	572 HF*	542 HF
CX	650 Turbo	83 - 86	542 HF*	542 HF
FMX	650	05 - 08	627 HS	657 LS
GL	650 D	83 - 84	542 HF*	2059
NT	650 Hawk GT	88 - 91	627 HS	614 LS
NT	650 V Deauville	98 - 00	674 HS*	614 LS
NT	650 V Deauville	01	674 HS*	657 LS
NT	650 V Deauville	02 - 05	735 HS*	736 LS
NX	650 Dominator J-K	88 - 92	647 HS	614 LS
TRX	650 FA Rincon	03 - 05	2085	813 SI
TRX	650 FGA Rincon	04 - 05	2085	813 SI
XR	650 L	93 - 18	694 HF	604 HF
XR	650 R	00 - 11	694 SI	604 SI
DN-01	680 (Parking Brake)	08 - 11		209 HF
DN-01	680	08 - 11	828 HS*	630 LS
TRX	680 FA6 Rincon	06 - 15	829 SI*	813 SI
TRX	680 FGA6 Rincon	06 - 15	829 SI*	813 SI
CB	700 SC	84 - 86	542 HF*	2046
CTX	700	14 - 18	700 HS	881 LS
CTX	700 D ABS w/DCT	13 - 15	700 HS	881 LS
	(Parking Brake)	13 - 15		879 HF
CTX	700 N	14 - 18	700 HS	881 LS
CTX	700 ND ABS w/DCT	14 - 15	700 HS	881 LS
CTX	700 ND ABS w/DCT	14 - 15		879 HF
	(Parking Brake)	14 - 15		879 HF

\* = 2 sets required / 2 jeux pour l'Avant.

Full compound selection, see under "Brake pad 1:1 Drawings" / Sélection complète de composés, voir "1:1 Schémas Plaquettes de frein".  
For ABE type approvals, see page 1 / Pour les homologations de type ABE, voir page 2.

**RECOMMENDED**1xx = Scooter Pads  
5xx = Street, Off Road & Racing Pads  
2xxx = Brake Shoes

HONDA					
NC	700	D Integra	12 - 13	828 HS	657 LS
NC	700	D Integra w/DCT (Parking Brake)	12 - 13		879 HF
NC	700	S	12 - 13	627 HS	614 LS
NC	700	SA ABS	12 - 13	828 HS	657 LS
NC	700	SD ABS	12 - 13	828 HS	657 LS
NC	700	SD ABS w/DCT (Parking Brake)	12 - 13		879 HF
NC	700	X	12 - 13	627 HS	614 LS
NC	700	XA ABS	12 - 13	828 HS	657 LS
NC	700	XD ABS	12 - 13	828 HS	657 LS
NC	700	XD ABS w/DCT (Parking Brake)	12 - 13		879 HF
NM4	700	Vultus ABS w/DCT	15	700 HS	881 LS
NM4	700	Vultus ABS w/DCT (Parking Brake)	15		879 HF
NT	700	Deauville ABS	06 - 12	828 HS*	736 LS
NT	700	V Varadero, ABS	10 - 13	828 HS*	736 LS
TRX	700	XX	08 - 12	694 SI*	829 SI
VF	700	C Magna	84	542 HF*	2059
VF	700	C Magna	85 - 86	572 HF*	2046
VF	700	C Magna	87	542 HF	2046
VF	700	F Interceptor	84 - 85	572 HF*	542 HF
VF	700	S	84 - 85	542 HF*	2059
VFR	700	F Interceptor	88 - 89	627 HS*	614 LS
VFR	700	F, F2	86 - 87	600 HS*	542 LS
VT	700	C Shadow	84 - 85	561 HF*	2059
VT	700	C Shadow	86	561 HF*	2046
VT	700	C, Shadow	87	542 HF	2046
	750	X-ADV	17 - 18	940 HS*	881 LS
	750	X-ADV (Parking Brake)	17 - 18		879 HF
CB	750	A	76 - 78	501 HF	2027
CB	750	C	80 - 81	526 HF*	2027
CB	750	C	82 - 84	542 HF*	2027
CB	750	C, F, Fil, K	85 - 86	542 HF*	2027
CB	750	F	77 - 80	517 HF*	517 HF
CB	750	F	81 - 82	542 HF*	542 HF
CB	750	F1	75 - 76	501 HF	509 HF
CB	750	K	81 - 82	542 HF*	542 HF
CB	750	K Four	77 - 78	501 HF	2027
CB	750	K, L	79 - 80	526 HF*	2027
CB	750	K0-K6 Four	70 - 76	502 HF	2027
CB	750	KZ	82	542 HF	2027
CB	750	N, F, Seven Fifty	92 - 95	627 HS*	657 LS
CB	750	Nighthawk	91 - 02	627 HS	2059
CB	750	PZ	81 - 84	526 HF	2027
CB	750	SC	82 - 83	572 HF*	2027
CB	750	SS	77 - 79	508 HF*	517 HF
NC	750	D Integra	14 - 18	700 HS	881 LS
NC	750	D Integra w/DCT (Parking Brake)	14 - 18		879 HF
NC	750	S w/DCT	14 - 18	700 HS	881 LS
NC	750	S w/DCT (Parking Brake)	14 - 18		879 HF
NC	750	X w/DCT	14 - 18	700 HS	881 LS
NC	750	X w/DCT (Parking Brake)	14 - 18		879 HF
VF	750	C	82 - 84	542 HF*	2059
VF	750	C, CD Magna	94 - 98	630 HS	2046
VF	750	C, Magna	88 - 93	542 HF	2046
VF	750	F	83 - 84	542 HF*	542 HF
VF	750	Sport	82 - 83	542 HF*	2059
VFR	750	F	86 - 87	600 HS*	542 LS
VFR	750	F	88 - 98	627 HS*	630 LS
VFR	750	R	88 - 93	622 HS*	623 LS
VT	750	Black Widow	01 - 03	700 HS	2046
VT	750	C	83 - 85	561 HF	2059
VT	750	C, Shadow	86 - 96	542 HF	2046

**RECOMMENDED**1xx = Scooter Pads  
5xx = Street, Off Road & Racing Pads  
2xxx = Brake Shoes

HONDA					
VT	750	C2 Shadow A.C.E.	97 - 03	700 HS	2046
VT	750	C2 Shadow Spirit	07 - 11	700 HS	2046
VT	750	C2B	11 - 18	700 HS	
VT	750	C2B Phantom	10 - 18	700 HS	2046
VT	750	C2S ABS	13 - 14	828 HS	715 LS
VT	750	C4 Shadow	04 - 05	700 HS	2046
VT	750	CS ABS	13 - 14	828 HS	715 LS
VT	750	RS	11 - 13	700 HS	
VT	750	S	11 - 12	700 HS	
VT	750	Shadow Aero	13 - 18	700 HS	715 LS
PC	800	Pacific Coast	89 - 97	627 HS*	2046
VFR	800	Crossrunner	11 - 13	828 HS*	862 LS
VFR	800	F	14 - 18	809 HS*	862 LS
VFR	800	FI Interceptor, ABS	02 - 05	735 HS*	736 LS
VFR	800	Interceptor	98 - 01	735 HS*	736 LS
VFR	800	Interceptor	06 - 18	828 HS*	736 LS
VFR	800	Interceptor ABS	06 - 18	828 HS*	736 LS
VFR	800	X Crossrunner	15 - 18	809 HS*	862 LS
VT	800	C	88 - 94	542 HF	2046
CB	900	C	82	542 HF*	542 HF
CB	900	F	78 - 80	517 HF*	517 HF
CB	900	F, F2	81 - 84	572 HF*	542 HF
CBR	900	RR	98 - 99	734 HS*	657 LS
CBR	900	RR Fireblade	92 - 97	622 HS*	657 LS
	919		02	622 HS*	657 LS
CBR	929	RR	00 - 01	734 HS*	657 LS
CBR	954	RR	02 - 03	734 HS*	657 LS
CB	1000	C	83 - 84	542 HF*	542 HF
CB	1000	F (Big One)	93 - 97	622 HS*	657 LS
CB	1000	R	18 -	947 HS*	862 LS
CB	1000	R	08 - 16	809 HS*	862 LS
CB	1000	R ABS	08 - 16	828 HS*	862 LS
CB	1000	R+	18 -	947 HS*	862 LS
CBR	1000	F	87 - 88	600 HS*	542 LS
CBR	1000	F	89 - 92	627 HS*	630 LS
CBR	1000	F, FP	93 - 99	685 HS*	685 LS
CBR	1000	RR Fireblade	04 - 05	809 HS*	657 LS
CBR	1000	RR Fireblade	06 - 08	809 HS*	834 LS
CBR	1000	RR Fireblade ABS	09 - 16	809 SP*	834 LS
CBR	1000	RR Fireblade	17 - 18	947 SP*	834 LS
CBR	1000	RR SP	14 - 18	901 SP*	834 LS
CBR	1000	RR SP2	17 - 18	901 SP*	834 LS
CBX	1000		78 - 80	517 HF*	517 HF
CBX	1000		81 - 82	572 HF*	542 HF
CRF	1000	L Africa Twin	16 - 18	940 HS*	657 LS
CRF	1000	L Africa Twin (Parking Brake)	16 - 18		879 HF
CRF	1000	L Africa Twin Adventure Sports	18 -	940 HS*	657 LS
CRF	1000	L Africa Twin Adventure Sports (Parking Brake)	18 -		879 HF
GL	1000	Gold Wing	81	517 HF*	517 HF
GL	1000	Gr. Tour. Gold Wing	81 - 82	517 HF*	517 HF
GL	1000	K1, K2 Gold Wing	75 - 77	508 HF*	509 HF
GL	1000	K3 Gold Wing	78 - 79	517 HF*	509 HF
RC213V-S	1000		16 - 18	901 SP*	730 LS
RVT	1000	RC51	00 - 06	734 HS*	657 LS
VF	1000	F, Fil	84 - 86	542 HF*	542 HF
VF	1000	R	84 - 87	542 HF*	
VTR	1000	SP-1, SP-2	00 - 06	734 HS*	657 LS
VTR	1000	Super Hawk	97 - 07	622 HS*	657 LS
CB	1100	, EX	14 - 18	734 HS*	657 LS
CB	1100		13	828 HS*	657 LS
CB	1100	EX ABS	17 - 18	734 HS*	657 LS
CB	1100	F	83 - 85	542 HF*	542 HF
CB	1100	RS ABS	17 - 18	947 HS*	657 LS
CB	1100	X-11	00 - 03	735 HS*	736 LS

\* = 2 sets required / 2 jeux pour l'Avant.





**RECOMMENDED**

1xx = Scooter Pads  
5xx = Street, Off Road & Racing Pads  
2xxx = Brake Shoes



HONDA				
CBR	1100 XX Super Blackbird	96 - 07	735 HS*	736 LS
GL	1100 -1, DLX Gold Wing	81 - 87	542 HF*	542 HF
GL	1100 A Gold Wing	79 - 83	517 HF*	517 HF
GL	1100 Gold Wing	82 - 83	572 HF*	542 HF
ST	1100 A6 ABS-TCS-CBS	96 - 01	721 HS*	722 LS
ST	1100 ABS-TCS	92 - 95	627 HS*	654 LS
VF	1100 C	83 - 86	572 HF*	542 HF
VF	1100 S	84 - 85	572 HF*	542 HF
VT	1100 C Shadow	87 - 93	542 HF	2046
VT	1100 C Shadow	94 - 96	627 HS*	2046
VT	1100 C2 Shadow A.C.E.	95 - 04	627 HS	657 LS
VT	1100 C2 Shadow Sabre	00 - 05	627 HS	657 LS
VT	1100 C3 Shadow Aero	98 - 04	627 HS	657 LS
VT	1100 T Shadow	98 - 04	627 HS*	657 LS
GL	1200 A, I Gold Wing	84 - 86	572 HF*	542 HF
GL	1200 DX Gold Wing	86 - 87	572 HF*	542 HF
GL	1200 Gold Wing	84 - 86	572 HF*	542 HF
VFR	1200 F	10 - 18	869 HS*	862 LS
VFR	1200 F w/DCT	10 - 18	869 HS*	892 LS
VFR	1200 F w/DCT (Parking Brake)	10 - 18		879 HF
VFR	1200 XC Crosstourer	12 - 18	828 SP*	892 LS
VFR	1200 XDC Crosstourer w/DCT	12 - 18	828 SP*	892 LS
VFR	1200 XDC Crosstourer w/DCT (Parking Brake)	12 - 18		879 HF
CB	1300	05 - 13	734 HS*	657 LS
CB	1300 R	02 - 04	734 HS*	715 LS
CB	1300 S	11 - 15	828 HS*	657 LS
CTX	1300	14 - 18	828 HS*	630 LS
ST	1300 , ABS	02 - 07	735 HS*	722 LS
ST	1300 , ABS	08 - 13	828 HS*	722 LS
VT	1300 CX A Fury	10 - 18	627 HS	657 LS
VT	1300 CXA A Fury ABS	10 - 18	828 HS	736 LS
VT	1300 Interstate	11 - 15	627 HS	657 LS
VT	1300 Sabre	11 - 13	627 HS	657 LS
VT	1300 Stateline	11 - 16	627 HS	657 LS
VTX	1300 C	04 - 09	627 HS	657 LS
VTX	1300 S	03 - 07	627 HS	657 LS
GL	1500 Gold Wing Aspencade, Interstate, SE	94 - 00	647 HS*	542 LS
GL	1500 Gold Wing, Gold Wing SE	88 - 99	647 HS*	542 LS
GL	1500 Valkyrie	96 - 03	627 HS*	630 LS
GL	1800 C Valkyrie	14 - 15	734 HS*	880 LS
GL	1800 Gold Wing	01 - 16	735 HS*	880 LS
GL	1800 Gold Wing F6B	13 - 16	735 HS*	880 LS
NRX	1800 Valkyrie Rune	04 - 05	735 HS*	736 LS
VTX	1800	01 - 12	735 HS*	736 LS
<b>HUSABERG</b>				
	all models	89 - 92	608 SI	586 SI
	all models	93 - 98	671 SI	586 SI
TE	125	13	671 SI	791 SI
FE	250	13	671 SI	791 SI
TE	250	11 - 13	671 SI	791 SI
TE	300	11 - 13	671 SI	791 SI
	350	91 - 92	608 SI	586 SI
FE	350	13	671 SI	791 SI
FE	390	10 - 13	671 SI	791 SI
FC	400	99 - 02	671 RSI	675 RSI
FE	400 ,S,E	99 - 03	671 SI	675 SI
FS	400 e, c	01 - 03	631 RSI	675 RSI
FC	450	03 - 08	671 RSI	675 RSI
FE	450	09 - 13	671 SI	791 SI
FE	450 e	04 - 08	671 SI	675 SI
FS	450 c	06 - 08	842 RSI	675 RSI
FS	450 e, c	03 - 05	631 RSI	675 RSI



**RECOMMENDED**

1xx = Scooter Pads  
5xx = Street, Off Road & Racing Pads  
2xxx = Brake Shoes



HUSABERG				
FX	450 e	03 - 08	671 RSI	675 RSI
FC	470 , e	01 - 02	671 RSI	675 RSI
FX	470 e	01 - 02	671 RSI	675 RSI
	500	91 - 98	608 SI	586 SI
	501 Enduro	91 - 94	608 SI	586 SI
FC	501	99 - 01	671 RSI	675 RSI
FE	501 ,S,E	99 - 04	671 SI	675 SI
FE	501	13	671 SI	791 SI
FC	550	01 - 05	671 RSI	675 RSI
FE	550 e	04 - 08	671 SI	675 SI
FE	570	09 - 13	671 SI	791 SI
	600 Enduro	91 - 94	608 SI	586 SI
FC	600	99 - 01	671 RSI	675 RSI
FE	600 ,S,E	99 - 02	671 SI	675 SI
FE	650 e	01 - 08	671 SI	675 SI
FS	650 e, c	01 - 05	631 RSI	675 RSI
FS	650 e, c	06 - 08	842 RSI	675 RSI
FX	650 e	01 - 05	671 RSI	675 RSI
<b>HUSQVARNA</b>				
	all models	72 - 79	2116	2116
	all models	87 - 88		2116
	all models CR,TC,TE, WR	92 - 94	611 SI	536 SI
	all models TE,TC,WR, CR,AE	89	608 SI	2116
	all rear drum models	86		2117
	50 Husky Boy J, R, S	01 - 10	559 RSI	
	50 Racing	98	105 HF	
CR	50 Junior	06	803 RSI	
CR	50 Pro Senior	06	803 RSI	794 RSI
CR	50 Senior	06	803 RSI	794 RSI
SM	50	10 - 12	803 HF	794 RSI
TC	50	17 - 18	794 RSI	794 RSI
CR	65	12 - 13	783 RSI	872 RSI
TC	65	17 - 18	783 RSI	783 RSI
TC	85	14 - 18	885 RSI	872 RSI
CR	125	83 - 84	2118	2116
CR	125	85 - 90	519 SI	2117
CR	125	96 - 04	671 RSI	675 RSI
CR	125	05 - 13	671 RSI	791 RSI
CR/RL	125	81 - 82	2117	2116
CR/WR	125	91	608 SI	692 SI
CX	125	84 - 85	519 SI	
SM	125 S	09 - 13	671 HF	675 HF
SM	125 S 4T	11 - 13	671 HF	675 HF
SM	125 Supermotard, S	99 - 13	671 HF	675 HF
TC	125	14 - 18	671 RSI	791 RSI
TE	125	14 - 16	671 SI	791 SI
TE	125 4T	11 - 13	671 HF	675 HF
TX	125	17 - 18	671 SI	791 SI
WR	125	80	2117	2116
WR	125	85 - 90	608 SI	2117
WR	125	96 - 13	671 SI	675 SI
WR/XC	125	82	2117	2117
WR/XC	125	83 - 84	2118	2117
WRE	125	96 - 13	671 SI	675 SI
WRK	125	90	608 SI	586 SI
XC	125	85		2116
	200 Prof	86	519 SI*	519 SI
CR	240	84 - 85	519 SI	
WR	240	87 - 90	608 SI	
WR	240	91	608 SI	692 SI
WRK	240	90	608 SI	586 SI
CR	250	81 - 82	2117	2116
CR	250	83 - 84	2118	2116
CR	250	85 - 87	519 SI	2117
CR	250	91	608 SI	692 SI

\* = 2 sets required / 2 jeux pour l'Avant.

Full compound selection, see under "Brake pad 1:1 Drawings" / Sélection complète de composés, voir "1:1 Schémas Plaquettes de frein".  
For ABE type approvals, see page 1 / Pour les homologations de type ABE, voir page 2.

**RECOMMENDED**1xx = Scooter Pads  
5xx = Street, Off Road & Racing Pads  
2xxx = Brake Shoes

HUSQVARNA					
CR	250	96 - 04	671 RSI	675 RSI	
CR	250	05	671 RSI	791 RSI	
CX	250	84 - 85	519 SI		
FC	250	14 - 18	671 RSI	791 RSI	
FE	250	14 - 18	671 SI	791 SI	
TC	250	02 - 03	671 RSI	675 RSI	
TC	250	04 - 18	671 RSI	791 RSI	
TE	250	02 - 13	671 SI	675 SI	
TE	250	14 - 18	671 SI	791 SI	
TE	250 4T	10 - 13	671 SI	791 SI	
WR	250	96 - 13	671 SI	675 SI	
WR/OR	250	80	2117	2116	
WR/XC	250	81 - 82	2117	2117	
WR/XC	250	83 - 84	2118	2117	
WR/XC	250	87 - 90	608 SI		
WR	260	90 - 93	608 SI	692 SI	
TC	300	14 - 15	671 RSI	791 RSI	
TE	300	14 - 18	671 SI	791 SI	
WR	300	09 - 13	671 SI	791 SI	
TE	310 4T	10 - 13	671 SI	791 SI	
FC	350	14 - 18	671 RSI	791 RSI	
FE	350	14 - 18	671 SI	791 SI	
TE	350	96 - 13	671 SI	675 SI	
TE	350 Enduro	90	608 SI	586 SI	
WR	360	98 - 13	671 SI	675 SI	
WR/OR	390	80	2117	2116	
WR/XC	390	82	2117	2117	
	400 Enduro	85 - 88	519 SI	2117	
SM	400 R	02	566 HF	675 HF	
TE	400	01 - 13	671 SI	675 SI	
WR	400	87 - 88	608 SI	2117	
WRX	400	85	2118	2116	
	401 Svartpilen	17 - 18	877 HS	675 LS	
	401 Vitpilen	17 - 18	877 HS	675 LS	
TE	410	96 - 13	671 SI	675 SI	
	430 Auto	87	608 SI	2117	
	430 Enduro	85 - 88	519 SI	2116	
CR	430	82	2117	2116	
CR	430	87 - 89	608 SI	2117	
CR/WR/CS	430	81	2117	2117	
WR	430	87 - 89	608 SI	2116	
XC	430	87 - 88	608 SI	2117	
SMR	449	11 - 13	762 RS	791 RSI	
TC	449	11 - 13	671 RSI	791 RSI	
TE	449	11 - 13	671 SI	791 SI	
FC	450	14 - 18	671 RSI	791 RSI	
FE	450	14 - 18	671 SI	791 SI	
FS	450	15 - 18	841 RS	791 RSI	
SM	450 R	03 - 04	566 HF	675 HF	
SM	450 R	05	762 RS	675 RSI	
SM	450 R	06 - 13	762 RS	791 RSI	
SM	450 RR	06 - 10	762 RS	791 RSI	
TC	450	02 - 03	671 RSI	675 RSI	
TC	450	04 - 10	671 RSI	791 RSI	
TE	450	02 - 10	671 SI	675 SI	
TE	450	14	671 SI	791 SI	
CR	500	83 - 84	2118	2116	
CR	500	86 - 87	519 SI	2117	
CX/CR	500	84 - 85	519 SI	2116	
TC	500	86	519 SI	2117	
WR/XC/AE	500	83 - 84	2118	2117	
XC	500	87 - 88	608 SI	2117	
FE	501	14 - 18	671 SI	791 SI	
	504	83	519 SI	2117	
	510	87 - 89	608 SI	2117	
	510	90	608 SI	586 SI	
SM	510 Centennial	06	762 RS	791 RSI	
SM	510 R	05	762 RS	675 RSI	

**RECOMMENDED**1xx = Scooter Pads  
5xx = Street, Off Road & Racing Pads  
2xxx = Brake Shoes

HUSQVARNA					
SM	510 R	06 - 10	762 RS	791 RSI	
TC	510	02 - 03	671 RSI	675 RSI	
TC	510	04 - 10	671 RSI	791 RSI	
TE	510	86 - 87	519 SI	2117	
TE	510	02 - 10	671 SI	675 SI	
TE	510 Centennial	04 - 05	671 SI	675 SI	
SMR	511	11 - 13	762 RS	791 RSI	
TE	511	11 - 14	671 SI	791 SI	
	570 Nox	01 - 03	706 HF	675 HF	
SM	570 R	01 - 08	566 HF	675 HF	
TC	570	01 - 13	671 RSI	675 RSI	
TE	570	01 - 13	671 SI	675 SI	
LT	610	00 - 02	706 HF	675 HF	
SM	610 ie	07 - 10	762 RS	791 RSI	
SM	610 Super Motard, S	98 - 00	706 HF	675 HF	
TC	610	96 - 13	671 RSI	675 RSI	
TC	610 Cross	91	608 SI	692 SI	
TE	610	91 - 95	608 SI	692 SI	
TE	610 Rallye	96 - 13	671 RSI	675 RSI	
SM	630	10	762 HS	791 HF	
SMR	630	04 - 08	706 RS	675 RSI	
TE	630	10 - 13	671 HS	791 HF	
TE	630	14	671 SI	791 SI	
STR	650 CRC	07	762 HF	791 HF	
TR	650 Strada	13	674 HS	675 LS	
TR	650 Terra	13	674 HS	675 LS	
	701 Svartpilen	18 -	706 HS	675 LS	
	701 Vitpilen	18 -	706 HS	675 LS	
FE	701 Enduro	17	674 HS	675 LS	
SM	701 Supermoto	15 - 18	762 HS	675 LS	
	900 Nuda	12 - 13	706 HS*	675 LS	
	900 Nuda R, ABS	12 - 13	841 HS*	675 LS	

HYOSUNG					
	50 Avanti	99 - 02	101 HF		
	50 Rush	97 - 01	101 HF		
	50 Sense	98 - 07	101 HF		
	50 Super Cab	95 - 98	101 HF		
	50 Super Cab Plus	98	101 HF		
SB	50	00 - 03	101 HF		
SB	50 P	00 - 03	101 HF		
SD	50	00 - 06	101 HF		
SF	50	99 - 06	101 HF		
	100 Cab	98 - 01	101 HF		
EZ	100	00 - 05	101 HF		
	110 Midas Plus	98 - 04	101 HF	2015	
FX	110 110	02 - 04	101 HF	2015	
KR	110 Master	04 - 05	101 HF	2015	
	125 Aquila	00 - 04	611 HF		
	125 Boomer	03	123 CT	103 CT	
	125 Cruise II	99 - 06	524 HF		
	125 Cruise II Classic	99 - 06	524 HF		
	125 Cruiser	92 - 06	524 HF		
	125 Exceed	02 - 06	123 CT	103 CT	
	125 GA-4	99	557 HF		
	125 Grand Prix	98 - 04	123 CT		
	125 Grand Prix Plus	02 - 05	551 HF		
	125 Hyper	99 - 09	123 CT		
	125 V2	99 - 11	627 HF		
GA	125	98 - 06	524 HF		
GA	125 F	00 - 06	524 HF		
GD	125 EXIV	12 - 16	734 HF	544 HF	
GF	125	98 - 04	524 HF		
GPS	125 D	00 - 03	123 CT		
GS	125	99	524 HF		
GT	125	07 - 10	814 HF*	814 HF	
GT	125 Comet	02 - 03	551 HF		
GT	125 Comet	04 - 06	814 HF	814 HF	

\* = 2 sets required / 2 jeux pour l'Avant.





**RECOMMENDED**

1xx = Scooter Pads  
5xx = Street, Off Road & Racing Pads  
2xxx = Brake Shoes



HYOSUNG					
GT	125 Naked	13	814 HF*	814 HF	
GT	125 R Supersport	07 - 16	814 HF*	814 HF	
GV	125 Aguila	02 - 04	551 HF		
GV	125 Aguila	05 - 11	814 HF		
RT	125 Karion	02 - 06	551 HF		
RT	125 Karion	07 - 09	814 HF*	814 HF	
RX	125	00 - 07	551 HF		
RX	125 SM	07 - 11	814 HF*	814 HF	
TN	125	92 - 95	524 HF		
XRX	125	07 - 09	814 HF*	814 HF	
XRX	125 Offroad	99 - 06	551 HF		
	150 Exceed	02 - 04	123 CT	103 CT	
	150 Grand Prix	98 - 01	123 CT		
	250 Aquila	00 - 09	627 HF		
GD	250 EXIV-R	15 - 17	734 HS	747 HF	
GT	250 Comet	02	597 HS	556 LS	
GT	250 Comet	03 - 08	814 HF	814 HF	
GT	250 iR	13 - 14	814 HS*	814 LS	
GT	250 iR	15	734 HS*	747 HF	
GT	250 P	13	814 HF	814 HF	
GT	250 R	07 - 12	814 HF*	814 HF	
GV	250	02 - 09	551 HF	2014	
GV	250	17 - 18	734 HS	638 HF	
GA	300	98 - 01	557 HF		
GT	300 R	16 - 17	734 HS	747 HF	
GV	300	16 - 17	734 HS	638 HF	
TE	400	05 - 06	536 SI*	649 SI	
XRX	400	05 - 08	551 HF	604 HF	
RX	450 SM	08 - 11	762 HS	675 LS	
TE	450	07 - 11	536 SI*	649 SI	
	600 Comet	02	597 HS	556 LS	
	600 Comet	03	551 HF*		
GT	650	04 - 12	814 HS*	814 LS	
GT	650 i	13	734 HS*	814 LS	
GT	650 i Naked	15	734 HS*	814 LS	
GT	650 iR	13 - 14	734 HS*	814 LS	
GT	650 iR	15	734 HS*	747 HF	
GT	650 P	16	814 HS*	814 LS	
GT	650 R	05 - 13	814 HS*	814 LS	
GT	650 S	05 - 13	814 HS*	814 LS	
GT	650 TTC	07 - 11	814 HS*	814 LS	
GT	650 TTC / Custom Trendkiller	07 - 11	814 HS*	814 LS	
GT	650 X	07 - 11	814 HS*	814 LS	
GV	650 Aguila	04 - 05	551 HF*	769 HF	
GV	650 Aguila	06 - 11	814 HS*	814 LS	
ST	700	11 - 13	734 HS	814 LS	
ST	700 i Deluxe	13	734 HS	814 LS	

INDIAN					
	1000 Scout Sixty	16	929 H.HS	930 H.LS	
	1000 Scout Sixty	17 - 18	674 H.HS	675 H.LS	
	1130 Scout	01 - 08	678 H.HS	678 H.LS	
	1130 Scout	15 - 16	929 H.HS	930 H.LS	
	1200 Scout	17 - 18	674 H.HS	675 H.LS	
	1200 Scout Bobber	17 - 18	674 H.HS	675 H.LS	
	1700 Chief Blackhawk	11 - 13	566 H.HS*	506 H.LS	
	1700 Chief Bomber	10 - 13	566 H.HS*	506 H.LS	
	1700 Chief Classic	10 - 13	566 H.HS*	506 H.LS	
	1700 Chief Dark Horse	10 - 13	566 H.HS*	506 H.LS	
	1700 Chief Deluxe	09 - 13	566 H.HS*	506 H.LS	
	1700 Chief Roadmaster	09 - 13	566 H.HS*	506 H.LS	
	1700 Chief Standard	09 - 13	566 H.HS*	506 H.LS	
	1700 Chief Vintage	09 - 13	566 H.HS*	506 H.LS	
	1800 Chief	01 - 08	678 H.HS	678 H.LS	
	1800 Chief	15 - 18	782 H.HS*	630 H.LS	
	1800 Chief Classic	14 - 18	782 H.HS*	630 H.LS	
	1800 Chief Dark Horse	15 - 18	782 H.HS*	630 H.LS	



**RECOMMENDED**

1xx = Scooter Pads  
5xx = Street, Off Road & Racing Pads  
2xxx = Brake Shoes



INDIAN					
	1800 Chief Vintage	14 - 18	782 H.HS*	630 H.LS	
	1800 Chieftain	14 - 18	782 H.HS*	630 H.LS	
	1800 Chieftain Classic	15 - 18	782 H.HS*	630 H.LS	
	1800 Chieftain Dark Horse	15 - 18	782 H.HS*	630 H.LS	
	1800 Chieftain Limited	15 - 18	782 H.HS*	630 H.LS	
	1800 Dark Horse	16 - 18	782 H.HS*	630 H.LS	
	1800 Roadmaster	15 - 18	782 H.HS*	630 H.LS	
	1800 Roadmaster Classic	15 - 18	782 H.HS*	630 H.LS	
	1800 Roadmaster Elite	15 - 18	782 H.HS*	630 H.LS	
	1800 Springfield	16 - 18	782 H.HS*	630 H.LS	
	1800 Springfield Dark Horse	15 - 18	782 H.HS*	630 H.LS	

ITALJET					
	50 AJP Caliper				
	incl. pin/spring	90 - 18	188 HF		
	50 Bazooka	93 - 02	111 HF		
	50 Cruise	95 - 97	111 HF		
	50 Dragster	99 - 06	105 HF	105 HF	
	50 Formula	94 - 00	117 HF	123 HF	
	50 Formula Air	99 - 00	105 HF		
	50 Formula L.C.	98 - 00	105 HF	105 HF	
	50 Jet-Set	02 - 03	167 HF		
	50 Pista 2	92 - 97	111 HF		
	50 Rollercraft	08 - 12	200 HF	119 HF	
	50 Scoop	93 - 97	111 HF		
	50 Torpedo	98 - 99	105 HF		
	50 Torpedo 4T	01 - 03	105 HF		
	50 Yankee 8	94 - 02	111 HF	111 HF	
SM	50	02 - 05	148 HF		
SX1	50	08 - 10	141 HF		
	80 Formula	94 - 97	117 HF	123 HF	
	100 Millennium 2T	01	101 HF		
	100 Millennium 2T	01	167 HF		
	125 Amarcord	08 - 16	121 HF		
	125 Dragster	99 - 03	105 CT	105 CT	
	125 Formula	94 - 03	117 CT	123 CT	
	125 Formula L.C.	99 - 03	105 CT	105 CT	
	125 Jet-Set	02 - 03	167 CT		
	125 Jupiter	02 - 03	128 CT	105 CT	
	125 Millennium	00 - 03	101 CT		
	125 Millennium	00 - 03	167 CT		
	125 Torpedo	99 - 06	105 CT		
	125 Torpedo	08 - 11	200 CT	119 CT	
	125 Twin	98 - 01	105 CT	105 CT	
SM	125	02 - 05	652 HF		
	150 Jet-Set	02 - 03	167 CT		
	150 Jupiter	02 - 03	128 CT	105 CT	
	150 Millennium	00 - 03	101 CT		
	150 Millennium	00 - 03	167 CT		
	150 Torpedo	08 - 12	200 CT	119 CT	
	150 Torpedo 4T	01	105 CT		
	180 Dragster	99 - 03	105 CT	105 CT	
	250 Jupiter	01 - 03	128 CT	173 CT	
	350	83	519 HF*		
	650 Bazooka	06	814 HS*	814 LS	
	650 Grifon	06 - 07	814 HS*	814 LS	
	900 Grifon	00	566 HF		

JAWA					
CZ	125 2T	95 - 00	506 HF		
CZ	125 MX	95 - 00	506 HF		
CZ	180	92	506 HF		
	300 Trail	93	506 HF		
	350	93 - 95	699 HF		

JOHN DEERE					
HPX	350 Gator	10 - 14	908 SI*	908 SI*	
	500 Buck EX, EXT Left/Rear	05	754 SI	767 SI	

\* = 2 sets required / 2 jeux pour l'Avant.

Full compound selection, see under "Brake pad 1:1 Drawings" / Sélection complète de composés, voir "1:1 Schémas Plaquettes de frein".  
For ABE type approvals, see page 1 / Pour les homologations de type ABE, voir page 2.

**RECOMMENDED**1xx = Scooter Pads  
5xx = Street, Off Road & Racing Pads  
2xxx = Brake Shoes

<b>JOHN DEERE</b>				
	500 Buck EX, EXT Right	05	767 SI	
	500 Buck Left/Rear	05	754 SI	767 SI
	500 Buck Right	05	767 SI	
	500 Trail Buck Left/Rear	05	754 SI	767 SI
	500 Trail Buck Right	05	767 SI	
XUV	625 Gator	11	912 ATS*	
	650 Trail Buck EX, EXT Left/Rear	05	754 SI	767 SI
	650 Trail Buck EX, EXT Right	05	767 SI	
	650 Trail Buck Left/Rear	05	754 SI	767 SI
	650 Trail Buck Right	05	767 SI	
XUV	825 Gator	11	912 ATS*	
XUV	855 D Gator	11	912 ATS*	

**JOTAGAS**

JT	125	14 - 18	939 RSI	803 RSI
JT	250	14 - 18	939 RSI	803 RSI
JT	280	14 - 18	939 RSI	803 RSI
JT	300	14 - 18	939 RSI	803 RSI

**KAWASAKI**

AE	50	81 - 82	2015	2015
AR	50	81 - 82	544 HF	2015
KX	60	83 - 03	2093	2093
KX	65	00 - 15	752 RSI	536 RSI
KD	80	80 - 87	2015	2015
KD	80	88 - 90	544 HF	2015
KX	80	79 - 82	2087	2087
KX	80	83	2092	2093
KX	80	84 - 87	544 SI	2093
KX	80	88 - 96	544 RSI	592 RSI
KX	80	97 - 00	726 RSI	592 RSI
KX	85	01 - 18	726 RSI	592 RSI
KX	85 II	01 - 13	726 RSI	592 RSI
KE	100	79 - 97	2015	2015
KH	100	76 - 77	2015	2015
KM	100	78 - 81	2015	2015
KX	100	88 - 96	544 RSI	592 RSI
KX	100	97 - 18	726 RSI	592 RSI
KLF	110 Mojave	87 - 88	2015	2183
KLT	110	84 - 86	2015	2183
KLX	110	02 - 18	2093	2015
J	125	15 - 18	183 CT	204 CT
KE	125	76 - 85	2039	2183
KLX	125	10 - 14	611 HF	536 HF
KLX	125 D-Tracker	10 - 14	611 HF	536 HF
KX	125	74 - 81	2039	2183
KX	125	82	544 SI	2183
KX	125	83 - 85	546 SI	2025
KX	125	86	546 RSI	586 RSI
KX	125	87 - 88	602 HF	586 SI
KX	125	89 - 93	611 RSI	632 RSI
KX	125	94	694 RSI	632 RSI
KX	125	95 - 08	694 RSI	604 RSI
Z	125 Pro	17 - 18	925 HF	536 HF
Z	125 Pro KRT Ed.	18 -	925 HF	536 HF
Z	125 Pro KRT SE	18 -	925 HF	536 HF
KLX	140 , L	08 - 18	611 SI	592 SI
KLX	150 D-Tracker	16 - 18	611 HF	536 HF
KLX	150 L	14 - 15	611 HF	536 HF
KLT	160	85	2015	2183
KDX	175	80 - 82	2039	2183
KE	175	76 - 78	2039	2183
KLF	185 Bayou	85		2038
KLF	185 Bayou	86 - 88	2040	2038
KLT	185	86 - 87	2015	2183
KDX	200	83 - 85	2056	2025

**RECOMMENDED**1xx = Scooter Pads  
5xx = Street, Off Road & Racing Pads  
2xxx = Brake Shoes

<b>KAWASAKI</b>				
KDX	200	93	611 SI	632 SI
KDX	200	94 - 99	694 SI	632 SI
KDX	200 C	86 - 88	546 SI	2025
KDX	200 SR	89 - 92	546 SI	632 SI
KLT	200	81 - 84	2015	2040
KZ	200	78 - 79	516 HF	2014
KDX	220 R	97 - 05	694 SI	632 SI
KLF	220 Bayou	88 - 02	2040	2038
EL	250	91 - 94	557 HF	2038
EL	250 Eliminator	88 - 89	557 HF	2038
EX	250 R Ninja	86 - 87	557 HF	557 HF
EX	250 R Ninja	88 - 07	597 HF	615 HF
EX	250 R Ninja	08 - 12	638 HF	638 HF
EX	250 SL Ninja	15 - 17	638 HS	638 LS
KDX	250	80 - 82	2040	2016
KDX	250	83 - 84	2040	2183
KDX	250 SR	91 - 94	611 SI	632 SI
KH	250	76 - 80	510 HF	2088
KL	250 (KLR 250)	85 - 97	546 HF	2056
KL	250	78 - 80	2040	2016
KL	250	80 - 84	2039	2056
KL	250 Super Sherpa	00 - 02	726 SI	586 SI
KLT	250	82 - 83	2015	2040
KLT	250 Police	84	2015	2040
KLT	250 Prairie	83 - 85	2015	2040
KLX	250	79 - 80	2039	2183
KLX	250	93 - 96	694 SI	632 SI
KLX	250	98 - 07	694 SI	604 SI
KLX	250	14 - 18	611 HF	604 HF
KLX	250 Camo	18 -	611 HF	604 HF
KLX	250 S	09 - 14	611 HF	604 HF
KLX	250 SF	09 - 10	611 HF	604 HF
KSF	250 Mojave	87 - 02	591 SI*	592 SI
KT	250 all models	75 - 80	2039	2183
KX	250	75 - 81	2040	2016
KX	250	82	544 SI	2183
KX	250	83 - 85	546 SI	2183
KX	250	86	546 RSI	586 RSI
KX	250	87 - 88	602 HF	586 SI
KX	250	89 - 93	611 RSI	632 RSI
KX	250	94	694 RSI	632 RSI
KX	250	95 - 08	694 RSI	604 RSI
KXF	250 Tecate	87 - 88	591 SI*	592 SI
KX-F	250	04 - 10	694 RSI	790 RSI
KX-F	250 DFI	11 - 18	694 RSI	790 RSI
KXT	250 Tecate	84	2040	544 HF
KXT	250 Tecate	85 - 86	546 SI	586 SI
KXT	250 Tecate	87 - 88	591 SI	592 SI
KZ	250	80 - 83	2016	2014
SC	250 Epsilon	02 - 06	146 MS*	174 MS
Z	250 SL	15 - 17	638 HF	638 HF
EX	300 R Ninja, ABS	13 - 17	638 HS	638 LS
J	300	14 - 18	183 MS	204 MS
KAF	300 Mule 500	92 - 95	2053	
KAF	300 Mule 550	03 - 05	2053	
KEF	300 Lakota	95 - 04	591 SI*	592 SI
KLE	300 Versys-X	17 - 18	627 HS	638 LS
KLF	300 A1, A2 Bayou	86 - 87	2054	2038
KLF	300 Bayou	88 - 04	546 SI*	2038
KLF	300 Bayou Left/Rear	89 - 05	611 SI	2197
KLF	300 Bayou Right	89 - 05	638 SI	
KLX	300 R	97 - 07	694 SI	604 SI
KVF	300 Brute Force	13 - 17	536 SI*	810 SI
KVF	300 Prairie	99 - 02	536 SI*	
KVF	300 Prairie 4x4	99 - 05	536 SI*	
Z	300	15 - 16	638 HS	638 LS
EX	305	83	557 HF	2038
KZ	305	81 - 82	540 HF	2038

\* = 2 sets required / 2 jeux pour l'Avant.





**RECOMMENDED**

1xx = Scooter Pads  
 5xx = Street, Off Road & Racing Pads  
 2xxx = Brake Shoes



KAWASAKI					
KZ	305	87 - 88	540 HF	2038	
S2A	350	73	503 HF	2088	
KVF	360 Prairie 2x4, 4x4	03 - 08	536 SI*		
	400 Ninja R Left/Rear	11	705 HS	687 LS	
	400 Ninja R Right	11	704 HS		
KFX	400	02 - 05	592 SI*	649 SI	
KH	400	76 - 78	510 HF	2088	
KLF	400 Bayou Left	93 - 99	611 SI	2197	
KLF	400 Bayou Right	93 - 99	638 SI		
KLX	400 R	03 - 04	694 SI	604 SI	
KLX	400 SR	03 - 04	694 HF	604 HF	
KVF	400 Prairie	97 - 98	536 SI*	2197	
KVF	400 Prairie 2x4	99 - 01	536 SI*		
KVF	400 Prairie 4x4	99 - 02	536 SI*		
KZ	400	74 - 77	510 HF	2088	
KZ	400	78 - 79	522 HF	2038	
KZ	400 H1 (LTD)	79	510 HF	2038	
Z	400 Ninja	18 -	638 HS*	638 LS	
Z	400 Ninja KRT	18 -	638 HS*	638 LS	
KX	420	80 - 81	2040	2016	
KZ	440 , LTD	83 - 85	540 HF	2038	
KZ	440	80 - 82	510 HF	2038	
KZ	440	83	540 HF	2038	
KZ	440 C	80 - 81	510 HF	2038	
KZ	440 C, Twin	81 - 83	540 HF	2038	
KZ	440 H	82 - 84	539 HF	540 HF	
KZ	440 LTD	80 - 82	510 HF	2038	
EN	450	85 - 90	557 HF	2060	
KFX	450 Left/Rear	07 - 15	801 SI	592 SI	
KFX	450 Right	07 - 15	798 SI		
KLX	450 R	07 - 12	694 SI	790 SI	
KX-F	450	06 - 08	694 RSI	790 RSI	
KX-F	450 DFI	09 - 18	694 RSI	790 RSI	
EN	500	90 - 96	557 HS	2060	
EN	500	98 - 04	557 HS	2060	
EN	500 Vulcan	96 - 97	557 HS	2060	
EX	500	87 - 89	597 HF	2038	
EX	500	90 - 93	597 HS	2038	
EX	500 Ninja	94 - 97	597 HS	586 LS	
KH	500	76 - 79	510 HF		
KH	500 H1	74 - 75	503 HF		
KX	500	83 - 85	546 SI	2183	
KX	500	86	546 RSI	586 RSI	
KX	500	87 - 88	602 HF	586 SI	
KX	500	89 - 93	611 RSI	632 RSI	
KX	500	94 - 95	694 RSI	632 RSI	
KX	500	96 - 04	694 RSI	604 RSI	
GPZ	550	84 - 87	557 HF*	557 HF	
KZ	550	80 - 83	540 HF	2060	
KZ	550	81 - 83	540 HF*	540 HF	
KZ	550	83 - 84	540 HF	2060	
KZ	550 A1	80	510 HF	2060	
ZR	550 A1, GP	83 - 84	546 HF*	2038	
ZR	550 Zephyr	90 - 92	597 HS*	615 LS	
ZX	550	84 - 89	557 HF*	557 HF	
	600 R, Ninja	89 - 96	631 HF*	556 HF	
KL	600	84 - 86	546 HF	2183	
KLR	600	84 - 86	546 HF	2183	
KLR	600 E	85 - 94	546 HF	2183	
ZL	600	85 - 86	557 HF	2060	
ZL	600 B2 Eliminator	95 - 98	597 HS	2060	
ZX	600 Ninja	85 - 87	557 HF*	557 HF	
ZX	600 Ninja	90 - 93	631 HS*	597 LS	
ZX	600 Ninja R	88 - 97	597 HS*	597 LS	
ZX-6R	600 (Ninja ZX6)	93 - 97	631 HS*	687 LS	
ZX-6R	600 (Ninja ZX6R)	95 - 97	631 HS*	687 LS	
ZX-6R	600 (ZX6)	90 - 93	631 HS*	597 LS	
ZX-6R	600 Ninja	98 - 01	686 HS*	687 LS	



**RECOMMENDED**

1xx = Scooter Pads  
 5xx = Street, Off Road & Racing Pads  
 2xxx = Brake Shoes



KAWASAKI					
ZX-6R	600 Ninja	07 - 12	838 HS*	687 LS	
ZX-6RR	600 Ninja	03 - 06	788 HS*	687 LS	
ZX-6R	636 Ninja	02	686 HS*	687 LS	
ZX-6R	636 Ninja	03 - 06	788 HS*	687 LS	
ZX-6R	636 Ninja	13 - 18	894 HS*	834 LS	
ZX-6R	636 Ninja ABS	13 - 18	894 HS*	834 LS	
ZX-6R	636 Ninja KRT ABS	13 - 18	894 HS*	834 LS	
	650 R Ninja Left/Rear	06 - 08	705 HS	687 LS	
	650 R Ninja Right	06 - 08	704 HS		
EN	650 Vulcan S	15 - 18	735 HS	657 LS	
EN	650 Vulcan S Cafe	17 - 18	735 HS	657 LS	
EN	650 Vulcan S SE	17 - 18	735 HS	657 LS	
EX	650 Ninja ABS	17 - 18	735 HS	657 LS	
EX	650 Ninja KRT ABS	17 - 18	735 HS	657 LS	
KLE	650 Versys Left/Rear	07 - 14	705 HS	687 LS	
KLE	650 Versys Right	07 - 14	704 HS		
KLE	650 Versys	15 - 18	627 HS*	881 LS	
KLE	650 Versys LT	15 - 16	627 HS*	881 LS	
KLR	650	87 - 07	602 HF	586 SI	
KLR	650	95 - 04	705 HS	586 LS	
KLR	650	08 - 18	611 HS	638 LS	
KLR	650 Camo	08 - 18	611 HS	638 LS	
KLR	650 Tengai	89 - 92	597 HS	586 LS	
KLX	650	93 - 96	694 SI	632 SI	
KLX	650 R	93 - 95	694 SI	632 SI	
KLX	650 R D1	96	694 SI	604 SI	
KVF	650 Brute Force 4x4 Left	05 - 11	801 SI		
KVF	650 Brute Force 4x4 Right	05 - 11	798 SI		
KVF	650 Brute Force 4x4i Left	05 - 11	611 SI		
KVF	650 Brute Force 4x4i Right	05 - 11	638 SI		
KVF	650 Prairie Left	01 - 03	801 SI		
KVF	650 Prairie Right	01 - 03	798 SI		
KZ	650 , CSR	81 - 82	540 HF		
KZ	650	77 - 79	510 HF*	2060	
KZ	650	78 - 82	510 HF*	512 HF	
KZ	650	80	510 HF	2060	
KZ	650	81 - 84	539 HF	2060	
KZ	650 C	78 - 79	510 HF*	514 HF	
KZ	650 F	81 - 84	539 HF*	2060	
W	650	99 - 05	704 HF	2038	
Z	650 ABS	17 - 18	627 HS*	657 LS	
KFX	700 V-Force Left	04 - 13	801 SI		
KFX	700 V-Force Right	04 - 13	798 SI		
KSV	700 V-Force Left	04 - 11	801 SI		
KSV	700 V-Force Right	04 - 11	798 SI		
KVF	700 Prairie Left	04 - 13	801 SI		
KVF	700 Prairie Right	04 - 13	798 SI		
KZ	700	83 - 88	539 HF*	540 HF	
VN	700 Vulcan	85	557 HF*	2060	
ZN	700	84 - 89	557 HF*	557 HF	
	750 Vulcan	93 - 94	557 HF	2060	
GPZ	750	82	539 HF	540 HF	
GPZ	750	83 - 87	557 HF*	557 HF	
GPZ	750 R	85 - 86	557 HF*	557 HF	
GPZ	750 T	83 - 85	557 HF*	557 HF	
KRF	750 Teryx 4x4 Left	08 - 13	611 SI		
KRF	750 Teryx 4x4 Right	08 - 13	638 SI		
KVF	750 Brute Force 4x4i Left	05 - 15	611 SI		
KVF	750 Brute Force 4x4i Right	05 - 15	638 SI		
KZ	750 , LTD	80 - 81	539 HF*	540 HF	
KZ	750 , Turbo	84 - 86	557 HF*	557 HF	
KZ	750	83 - 84	557 HF*	2060	
KZ	750	84 - 86	539 HF*	540 HF	
KZ	750 B	76 - 79	510 HF	514 HF	
KZ	750 E	80 - 81	539 HF*	540 HF	
KZ	750 Eliminator	88	557 HF*	557 HF	
KZ	750 GT	82 - 85	539 HF*	540 HF	
KZ	750 H	72 - 75	503 HF	2091	

\* = 2 sets required / 2 jeux pour l'Avant.

Full compound selection, see under "Brake pad 1:1 Drawings" / Sélection complète de composés, voir "1:1 Schémas Plaquettes de frein".  
 For ABE type approvals, see page 1 / Pour les homologations de type ABE, voir page 2.

**RECOMMENDED**1xx = Scooter Pads  
5xx = Street, Off Road & Racing Pads  
2xxx = Brake Shoes

KAWASAKI					
KZ	750 L	80 - 82	539 HF*	540 HF	
KZ	750 L	84 - 86	540 HF*	540 HF	
KZ	750 L3	83	540 HF*	540 HF	
KZ	750 LTD	80 - 81	510 HF*	2060	
KZ	750 LTD Belt Drive	83 - 85	539 HF*	540 HF	
KZ	750 LTD Twin	82	539 HF*	540 HF	
KZ	750 LTD Twin	83 - 85	557 HF	557 HF	
KZ	750 M1	82 - 85	540 HF	2060	
KZ	750 R1	82	540 HF*	540 HF	
KZ	750 Sp.	83 - 84	539 HF*	540 HF	
KZ	750 Y1, N, LTD	82 - 85	539 HF*	540 HF	
VN	750 Vulcan	86 - 94	557 HF*	2060	
Z	750 , ABS	07 - 12	627 HS*	657 LS	
Z	750 Left/Rear	04 - 06	705 HS	687 LS	
Z	750 R	11 - 12	838 HS*	881 LS	
Z	750 Right	04 - 06	704 HS		
Z	750 S Left/Rear	05 - 06	705 HS	687 LS	
Z	750 S Right	05 - 06	704 HS		
ZR	750 Zephyr	91 - 95	597 HS*	597 LS	
ZR-7S	750 Left/Rear	01 - 04	705 HS	704 LS	
ZR-7S	750 Right	01 - 04	704 HS		
ZX	750 E, GP	83 - 85	557 HF*	557 HF	
ZX-7R	750 Ninja	89 - 95	631 HS*	556 LS	
ZX-7R	750 Ninja	96 - 03	686 HS*	556 LS	
ZX-7RR	750 Ninja	96 - 02	676 HS*	715 LS	
	800 Mule Pro FX Left	15 - 17	611 SI		
	800 Mule Pro FX Right	15 - 17	638 SI		
KRF	800 Teryx BEF/CEF/DEF Left	14 - 17	611 SI		
KRF	800 Teryx BEF/CEF/DEF Right	14 - 17	638 SI		
KRT	800 Teryx 4 BEF/CEF/DEF Left	14 - 17	611 SI		
KRT	800 Teryx 4 BEF/CEF/DEF Right	14 - 17	638 SI		
VN	800 Vulcan Classic	96 - 06	705 HS	2060	
VN	800 Vulcan Drifter	99 - 03	705 HS	704 LS	
VN	800 Vulcan,Classic	95 - 97	557 HS	2060	
W	800	11 - 16	704 HS		
Z	800	13 - 16	782 HS*	881 LS	
Z	800 ABS	13 - 16	782 HS*	881 LS	
Z	800 e	13 - 16	627 HS*	881 LS	
Z	800 e ABS	13 - 16	782 HS*	881 LS	
KZ	900	76	510 HF*	514 HF	
KZ	900	76 - 77	510 HF	2091	
KZ	900 A	76 - 77	510 HF*	2091	
VN	900 Vulcan Classic	06 - 16	705 HS	886 LS	
VN	900 Vulcan Classic SE	11 - 16	705 HS	886 LS	
VN	900 Vulcan Custom	07 - 16	705 HS	886 LS	
Z	900	17 - 18	782 HS*	881 LS	
Z	900 RS	18 -	806 HS*	657 LS	
Z	900 RS Cafe	18 -	806 HS*	657 LS	
ZL	900 Eliminator	85 - 86	557 HF*	557 HF	
ZX	900	83 - 84	557 HF*	557 HF	
ZX-9R	900 Ninja	94 - 95	631 HS*	687 LS	
ZX-9R	900 Ninja	96 - 01	686 HS*	687 LS	
ZX-9R	900 Ninja	02 - 03	782 HS*	687 LS	
KLE	1000 Versys	12 - 18	631 SP*	657 LS	
KLE	1000 Versys ABS	15 - 16	631 SP*	657 LS	
KLE	1000 Versys LT	15 - 16	631 SP*	657 LS	
KLV	1000 Left/Rear	04 - 07	705 HS	657 LS	
KLV	1000 Right	04 - 07	704 HS		
KZ	1000	76 - 81	510 HF*	512 HF	
KZ	1000	87 - 01	539 HF*	540 HF	
KZ	1000 F1	80 - 82	539 HF*	512 HF	
KZ	1000 GL	80 - 82	510 HF*	512 HF	
KZ	1000 H1	80 - 83	510 HF*	512 HF	
KZ	1000 J	79 - 83	539 HF*	540 HF	

**RECOMMENDED**1xx = Scooter Pads  
5xx = Street, Off Road & Racing Pads  
2xxx = Brake Shoes

KAWASAKI					
KZ	1000 K, M, CSR	81 - 84	539 HF*	540 HF	
KZ	1000 LTD	81 - 84	539 HF*	540 HF	
KZ	1000 MKII	79 - 80	539 HF*	512 HF	
KZ	1000 Police	82 - 01	539 HF*	540 HF	
KZ	1000 Police Left/Rear	02 - 03	705 HS	886 LS	
KZ	1000 Police Right	02 - 03	704 HS		
KZ	1000 R Ninja	86 - 88	557 HF*	557 HF	
KZ	1000 RE1, R2	82 - 84	540 HF*	540 HF	
KZ	1000 ST	79 - 81	539 HF*	512 HF	
Z	1000	10 - 16	806 HS*	687 LS	
Z	1000 ABS	15 - 18	806 HS*	687 LS	
Z	1000	03 - 06	782 HS*	687 LS	
Z	1000	07 - 09	838 HS*	657 LS	
Z	1000 Ninja	14 - 16	806 HS*	687 LS	
Z	1000 SE	14 - 16	806 HS*	687 LS	
Z	1000 SX	11 - 13	806 HS*	687 LS	
ZG	1000 Concours	86 - 93	557 HF*	557 HF	
ZG	1000 Concours	94 - 03	597 HS*	557 LS	
ZL	1000	86 - 87	557 HF*	557 HF	
ZX	1000 H2 Carbon Ninja	17 - 18	841 SP*	730 LS	
ZX	1000 H2 Ninja	15 - 18	841 SP*	730 LS	
ZX	1000 H2 SX	18 -	806 HS*		
ZX	1000 H2R Ninja	15 - 18	841 SP*	730 LS	
ZX-10	1000	88 - 90	597 HS*	597 LS	
ZX-10R	1000 Ninja	04 - 07	788 HS*	687 LS	
ZX-10R	1000 Ninja	08 - 10	806 SP*	687 LS	
ZX-10R	1000 Ninja	11 - 15	806 SP*	834 LS	
ZX-10R	1000 Ninja	16 - 18	841 SP*	834 LS	
ZX-10R	1000 Ninja ABS	12 - 15	806 SP*	834 LS	
ZX-10R	1000 Ninja KRT	16 - 18	841 SP*	834 LS	
ZX-10R	1000 Ninja SE	18 -	841 SP*	834 LS	
ZX-10RR	1000 Ninja	17 - 18	841 SP*	834 LS	
GPZ	1100 (ZX 1100) Left/Rear	95 - 99	705 HS	687 LS	
GPZ	1100 (ZX 1100) Right	95 - 99	704 HS		
GPZ	1100	81 - 82	539 HF*	540 HF	
GPZ	1100	83 - 86	557 HF*	557 HF	
KZ	1100 , Spectre	82 - 83	539 HF*	540 HF	
KZ	1100 GP	81	539 HF	540 HF	
KZ	1100 GP	83 - 86	557 HF*	557 HF	
KZ	1100 L1, LTD	83	539 HF*	540 HF	
KZ	1100 R, LTD	84	557 HF*	557 HF	
ZN	1100 LTD	84	557 HF*	557 HF	
ZR	1100 Zephyr	92 - 95	631 HS*	597 LS	
ZRX	1100	96 - 00	686 HS*	556 LS	
ZX	1100	93 - 97	631 HS*	556 LS	
ZX	1100 GP	83	557 HF*	557 HF	
ZZR	1100	90 - 93	631 HS*	597 LS	
ZZR	1100	94 - 01	631 HS*	556 LS	
ZG	1200 Voyager XII	86 - 93	557 HS*	557 LS	
ZRX	1200	01 - 04	686 HS*	556 LS	
ZRX	1200 R	01 - 08	686 HS*	556 LS	
ZRX	1200 S	01 - 07	686 HS*	556 LS	
ZX-12R	1200 Ninja	00 - 03	686 HS*	556 LS	
ZX-12R	1200 Ninja	04 - 06	788 HS*	556 LS	
ZZR	1200	02 - 04	631 HS*	556 LS	
KZ	1300	79 - 81	530 HF*	512 HF	
ZN	1300	83 - 84	557 HF*	557 HF	
ZN	1300 Voy.	85 - 86	557 HF*	557 HF	
ZG	1400 Concours	07 - 10	838 HS*	715 LS	
ZX-14R	1400 Ninja	06 - 15	838 HS*	715 LS	
ZX-14R	1400 Ninja ABS	07 - 15	838 HS*	715 LS	
ZX-14R	1400 SE	16 - 18	841 HS*	715 LS	
VN	1500 Mean Streak	02 - 03	686 HS	886 LS	
VN	1500 Vulcan	87 - 92	557 HS	557 LS	
VN	1500 Vulcan Classic	97 - 99	705 HS	557 LS	
VN	1500 Vulcan Classic Fi	00 - 04	705 HS	886 LS	
VN	1500 Vulcan Drifter	99 - 02	705 HS	704 LS	

\* = 2 sets required / 2 jeux pour l'Avant.





**RECOMMENDED**

1xx = Scooter Pads  
 5xx = Street, Off Road & Racing Pads  
 2xxx = Brake Shoes



**RECOMMENDED**

1xx = Scooter Pads  
 5xx = Street, Off Road & Racing Pads  
 2xxx = Brake Shoes



KAWASAKI				
VN	1500	Vulcan Nomad Fi		
		Left/Rear	00 - 04	705 HS 886 LS
VN	1500	Vulcan Nomad Fi		
		Right	00 - 04	704 HS
VN	1500	Vulcan Nomad		
		Left/Rear	98 - 01	705 HS 557 LS
VN	1500	Vulcan Nomad Right	98 - 01	704 HS
VN	1500	Vulcan, SE	87 - 92	557 HS 557 LS
VN	1600	Mean Streak	04	686 HS* 886 LS
VN	1600	Mean Streak	05	788 HS* 886 LS
VN	1600	Nomad Left/Rear	05	705 HS 886 LS
VN	1600	Nomad Right	05 - 06	704 HS
VN	1600	Vulcan Classic		
		Left/Rear	03 - 08	705 HS 886 LS
VN	1600	Vulcan Classic Right	03 - 08	704 HS
VN	1700	Voyager Vaquero		
		Left/Rear	09 - 14	705 HS 886 LS
VN	1700	Voyager Vaquero Right	09 - 14	704 HS
VN	1700	Vulcan Classic		
		Left/Rear	09 - 14	705 HS 886 LS
VN	1700	Vulcan Classic Right	09 - 14	704 HS
VN	1700	Vulcan Nomad		
		Left/Rear	09 - 16	705 HS 886 LS
VN	1700	Vulcan Nomad Right	09 - 16	704 HS
VN	1700	Vulcan Voyager	09 - 16	631 HS* 886 LS
VN	2000	Vulcan	04 - 10	631 HS* 886 LS

KEEWAY				
	50	Flash	07 - 12	101 HF 2028
	50	Flash Electric	10 - 12	141 HF 2028
	50	Focus	06 - 15	141 HF
	50	Hurricane	06 - 16	101 HF 2028
	50	Matrix	06 - 15	141 HF 2028
	50	Matrix Electric	10 - 15	141 HF
	50	Matrix Racing Sport	10 - 16	141 HF
F-NKD	50		10 - 11	141 HF 2028
RY8	50		07 - 09	141 HF 2028
RY8	50		10 - 16	141 HF 200 HF
TX	50	SM	10 - 12	173 HF
	90	Hurricane	06 - 09	101 HF
	100	Partner	06 - 10	119 HF
	110	Partner	06 - 07	119 HF
	125	Arn	06 - 08	123 CT
	125	Enduro	07 - 08	774 HF 519 HF
	125	Focus	06 - 08	141 CT
	125	Matrix	06 - 08	141 CT
	125	Matrix Racing Sport	10 - 16	141 CT
	125	Speed	06 - 12	132 CT 119 CT
	125	Superlight	06 - 16	713 HF
	125	X-Ray	07 - 08	774 HF 519 HF
TX	125	SM	10 - 16	780 HF
	150	Arn	06 - 08	123 CT
	150	Focus	06 - 09	141 CT
	150	Matrix	06 - 08	141 CT
	150	Matrix Racing Sport	10 - 12	141 CT
	150	Speed	06 - 09	132 CT 119 CT
	150	Superlight	06 - 16	713 HF
	250	Land Cruiser	06 - 14	713 HF
	250	Supershadow	06 - 09	691 HF

KTM				
		Freeride Electric	12 - 14	885 RSI 872 RSI
		most models	94	671 SI 675 SI
E-SM		Freeride	15 - 16	885 RSI 872 RSI
E-SX		Freeride	15 - 16	885 RSI 872 RSI
E-XC		Freeride	15 - 18	885 RSI 872 RSI
MX		125 - 600 ccm.	91	546 SI 586 SI
SM	50	Supermoto	06	794 RSI 794 RSI

KTM				
SX	50		09 - 18	794 RSI 794 RSI
SX	50	Adventure	98 - 03	2074 2074
SX	50	Mini	09 - 18	794 RSI 794 RSI
SX	50	Pro Junior LC	02 - 05	794 RSI 2074
SX	50	Pro Senior LC	02 - 03	794 RSI 2074
SX	50	Pro Senior LC	04 - 09	794 RSI 794 RSI
SX	50	Senior Adventure	04 - 07	794 RSI 2074
SX	60		99	559 RSI
SX	65		00 - 01	559 RSI 574 RSI
SX	65		02 - 03	783 RSI 574 RSI
SX	65		04 - 08	783 RSI 794 RSI
SX	65		09 - 18	783 RSI 783 RSI
SX	85	(19"/16" wheels)	13 - 18	885 RSI 872 RSI
SX	85		04 - 10	783 RSI 783 RSI
SX	85		11	783 RSI 872 RSI
SX	85		12 - 18	885 RSI 872 RSI
	125		83	2120 2120
	125	Duke	11 - 18	877 HS 675 LS
	125	Sting	99	566 HF 675 HF
	125	SuperMoto	00 - 03	671 HF 675 HF
EXC	125		90	621 HF 621 HF
EXC	125	Enduro	99 - 03	671 SI 675 SI
EXC	125	Enduro	04 - 15	671 SI 791 SI
EXE	125		00	671 HF 675 HF
GS	125		83	2122 2120
GS	125		84 - 85	2122 2122
GS	125		88	621 HF 621 HF
GS	125		89 - 90	546 SI 586 SI
GS	125		92 - 97	671 SI 586 SI
LC	125		85	519 SI
LC	125		86	519 SI 519 SI
LC2	125		99	671 HF 675 HF
LL	125		83	2122 2120
MX	125		84	2122 2122
MX	125		85	519 SI 2122
MX	125		86	519 SI 519 SI
MX	125		88	621 HF 621 HF
MX	125		89 - 90	546 SI 692 SI
MX	125		92 - 93	671 SI 692 SI
RC	125		14 - 18	877 HS 675 LS
SX	125		96 - 03	671 RSI 675 RSI
SX	125		04 - 18	671 RSI 791 RSI
XC	125		85	519 SI 2122
XC	125		86 - 89	519 SI 519 SI
SX	144		07 - 08	671 RSI 791 RSI
SX	150		09 - 18	671 RSI 791 RSI
XC	150		10 - 14	671 RSI 791 RSI
	175		72 - 78	2120 2120
	175		79 - 82	2120 2121
	200	Duke	12 - 17	877 HS 675 LS
EXC	200	Enduro	99 - 03	671 SI 675 SI
EXC	200	Enduro	04 - 16	671 SI 791 SI
RC	200		14 - 18	877 HS 675 LS
SX	200		03 - 04	671 RSI 791 RSI
XC	200		06 - 09	671 RSI 791 RSI
XC-W	200		06 - 16	671 RSI 791 RSI
	250	Baja	86 - 89	519 SI 2122
	250	Country,Baja	85	519 SI 2122
	250	Cross	80 - 81	2120 2120
	250	Cross	82	2121 2121
	250	Cross	83	2118 2121
	250	Duke	14 - 15	877 HS 675 LS
	250	Freeride R	14 - 18	885 RSI 872 RSI
	250	GS,EXC,		
		Enduro Models	91	621 HF 586 SI
EXC	250		90	621 HF 621 HF
EXC	250	Enduro	99 - 03	671 SI 675 SI
EXC	250	Enduro	04 - 08	671 SI 791 SI

\* = 2 sets required / 2 jeux pour l'Avant.

Full compound selection, see under "Brake pad 1:1 Drawings" / Sélection complète de composés, voir "1:1 Schémas Plaquettes de frein".  
 For ABE type approvals, see page 1 / Pour les homologations de type ABE, voir page 2.

**RECOMMENDED**1xx = Scooter Pads  
5xx = Street, Off Road & Racing Pads  
2xxx = Brake Shoes

KTM					
EXC	250	Enduro 4T	99 - 03	671 SI	675 SI
EXC	250	Enduro 4T	04 - 06	671 SI	791 SI
EXC	250	TPI	18 -	671 SI	791 SI
EXC-F	250	Enduro	07 - 18	671 SI	791 SI
GS	250		83 - 85	2122	2122
GS	250		88	621 HF	621 HF
GS	250		89 - 90	546 SI	586 SI
LC	250		85	519 SI	
LC	250		86	519 SI	519 SI
MC	250		83 - 84	519 SI	519 SI
MX	250		83 - 84	519 SI	519 SI
MX	250		84	2122	2122
MX	250		85	519 SI	2122
MX	250		86	519 SI	519 SI
MX	250		88	621 HF	621 HF
MX	250		89 - 90	546 SI	692 SI
MX	250		92 - 93	671 SI	692 SI
MX	250	VC, Enduro	87 - 90	601 HF	601 HF
RC	250		14 - 15	877 HS	675 LS
SX	250		96 - 02	671 RSI	675 RSI
SX	250		03 - 18	671 RSI	791 RSI
SX-F	250		06 - 18	671 RSI	791 RSI
XC	250		85	519 SI	
XC	250		86 - 89	519 SI	519 SI
XC	250		06 - 14	671 RSI	791 RSI
XC-W	250		08 - 17	671 RSI	791 RSI
EXC	300		90	621 HF	621 HF
EXC	300		93 - 96	671 SI	586 SI
EXC	300	Enduro	99 - 03	671 SI	675 SI
EXC	300	Enduro	04 - 08	671 SI	791 SI
EXC	300	TPI	18 -	671 SI	791 SI
GS	300		85	2122	2122
MX	300		85 - 89		2122
MX	300		90	546 SI	586 SI
MX	300		92	671 SI	586 SI
XC	300	(Drum vers.)	85	2122	2122
XC	300		85	519 SI	2122
XC	300		86 - 90	519 SI	519 SI
XC	300		06 - 14	671 RSI	791 RSI
XC-W	300		06 - 08	671 RSI	791 RSI
	350	Country Cross	85	519 SI	2122
	350	Freeride	12 - 17	885 RSI	872 RSI
	350	GS	83 - 85	519 SI	2121
	350	GS (Drum vers.)	83 - 85	2122	2122
EXC	350		87	601 HF	601 HF
EXC	350		88 - 90	621 HF	621 HF
EXC-F	350		11 - 18	671 SI	791 SI
GS	350		87	601 HF	601 HF
GS	350		88 - 92	621 HF	621 HF
GS4	350	500 K4	82 - 83	519 SI	
K4	350	500 K4	82 - 83	519 SI	
LC4	350		92 - 95	546 SI	586 SI
MX	350		87	601 HF	601 HF
MX	350		88	621 HF	621 HF
SX-F	350		11 - 18	671 RSI	791 RSI
XC	350	, MC	81 - 83	519 SI	
XC-F	350		12 - 17	671 RSI	791 RSI
XCF-W	350		13 - 17	671 RSI	791 RSI
MX	360		96 - 97	671 SI	675 SI
SX	360		96 - 97	671 RSI	675 RSI
XC	360		96 - 97	671 SI	675 SI
EXC	380	Enduro	99	671 SI	675 SI
MX	380		98	671 SI	675 SI
SX	380		98 - 02	671 RSI	675 RSI
XC	380		98 - 03	671 SI	675 SI
	390	Duke	13 - 15	877 HS	675 LS
	390	GS	83	519 SI	2121
	390	GS (Drum vers.)	83	2122	2122

**RECOMMENDED**1xx = Scooter Pads  
5xx = Street, Off Road & Racing Pads  
2xxx = Brake Shoes

KTM					
RC	390		14 - 18	877 HS	675 LS
XC	390	, MC	81 - 83	519 SI	
	400	Enduro	87 - 90	601 HF	601 HF
EXC	400	Racing	00 - 03	671 SI	675 SI
EXC	400	Racing	04 - 07	671 SI	791 SI
LC4	400		93 - 02	671 SI	586 SI
LC4-E	400	Enduro	99 - 02	671 SI	675 SI
SC	400		99 - 00	671 SI	675 SI
SX	400	Racing	00 - 02	671 RSI	675 RSI
SXC	400	Tiainen Replica	99 - 00	671 SI	675 SI
XC-W	400		07 - 10	671 RSI	791 RSI
GS	420		84 - 87	2122	2122
XC	420	, MC	81 - 83	519 SI	
	450	Rally	11 - 16	674 SI	675 SI
EXC-F	450	Racing	04 - 18	671 SI	791 SI
SX	450	ATV	08 - 10	866 RSI*	867 RSI
SX	450	SM Factory Replica	04 - 07	566 RSI	791 RSI
SX	450	SMR	04 - 06	842 RSI	791 RSI
SX	450	SMR	07 - 12	843 RSI	791 RSI
SX	450	SMR	13 - 15	841 RS	791 RSI
SX-F	450		03 - 18	671 RSI	791 RSI
XC	450	ATV	08 - 10	866 SI*	867 SI
XC-F	450		06 - 17	671 RSI	791 RSI
XCF-W	450		07 - 15	671 RSI	791 RSI
MC	495	Leleu	82 - 83	519 SI	2121
MX	495		84	2122	2122
MX	495	Leleu	82 - 83	519 SI	2121
	500	Cross	82	2118	2121
EXC-F	500		12 - 18	671 SI	791 SI
GS	500	500 K4 Enduro	83	519 SI	2121
LC	500		85	519 SI	2122
LC	500		86 - 89	519 SI	519 SI
MX	500		83 - 84	2122	2122
MX	500		85	519 SI	2122
MX	500		86	519 SI	519 SI
MX	500		87	601 HF	601 HF
MX	500		88	621 HF	621 HF
MX	500		89 - 91	546 SI	692 SI
MX	500		92 - 93	671 SI	692 SI
XC	500	, MC	81 - 83	519 SI	
XCF-W	500		12 - 17	671 RSI	791 RSI
SX	505	ATV	08 - 12	866 RSI*	867 RSI
SX	505	Racing	07 - 09	671 RSI	791 RSI
XC	505	ATV	08 - 12	866 SI*	867 SI
XC-F	505		08 - 09	671 RSI	791 RSI
EXC	520	Racing	00 - 02	671 SI	675 SI
SX-F	520	Racing	00 - 02	671 RSI	675 RSI
EXC	525	Racing	03	671 SI	675 SI
EXC	525	Racing	04 - 06	671 SI	791 SI
SX	525	SMR	04 - 07	842 RSI	791 RSI
SX-F	525	Racing	03	671 RSI	675 RSI
SX-F	525	Racing	04 - 06	671 RSI	791 RSI
XC-F	525		07	671 RSI	791 RSI
XCF-W	525		07	671 RSI	791 RSI
EXC	530	Racing	08 - 11	671 SI	791 SI
XCF-W	530		09 - 11	671 RSI	791 RSI
SXC	540	Tiainen Replica	99 - 00	671 SI	675 SI
LC4	550		87 - 89	601 HF	601 HF
MX	550		87 - 90	601 HF	601 HF
SX	560	SMR	06 - 07	843 RSI	791 RSI
	600	Duke	93 - 94	566 HF	
4T	600	Enduro	84 - 86	519 SI	
EXC	600		87	601 HF	601 HF
EXC	600		88	621 HF	621 HF
GS	600		84	2122	2122
GS	600		85	519 SI	2122
LC4	600		88 - 91	601 HF	601 HF
LC4	600	Enduro	88 - 91	601 HF	601 HF

\* = 2 sets required / 2 jeux pour l'Avant.





**RECOMMENDED**

1xx = Scooter Pads  
5xx = Street, Off Road & Racing Pads  
2xxx = Brake Shoes



KTM				
LC4	600 Six Days	92	671 SI	586 SI
MC	600	88	601 HF	601 HF
MX	600	87	601 HF	601 HF
MX	600	88 - 89	621 HF	621 HF
XC	600 Cross	85	519 SI	
XCE	600 Cross	85	519 SI	
	620 Duke	96 - 98	566 HF	519 HF
LC4	620 Competition	99 - 02	671 SI	675 SI
LC4	620 Competition			
	SuperMoto	00 - 01	671 HF	675 HF
LC4	620 RXC	95	671 SI	675 SI
LC4	620 Supercompetition	01	671 HF	675 HF
SC	620	99 - 00	671 SI	675 SI
SX	620	95 - 99	671 RSI	675 RSI
LC4	625 SC Supermoto	02 - 04	671 HF	675 HF
SMC	625	05 - 06	706 HF	675 HF
SXC	625	03 - 04	671 HF	675 HF
	640 Duke	99 - 02	566 HF	519 HF
	640 Duke	03 - 06	706 HF	675 HF
LC4	640 Adventure	99 - 04	671 HF	675 HF
LC4	640 Adventure	05 - 07	674 HF	675 HF
LC4	640 Supermoto	03	566 HF	675 HF
LC4	640 Supermoto	04	706 HF	675 HF
LC4-E	640 Enduro	99 - 04	671 HF	675 HF
LC4-E	640 Supermoto	99 - 02	671 HF	675 HF
LC4	660 Rallye	01 - 03	671 HF	675 HF
LC4	660 SM Factory Replica	02	566 RSI	675 RSI
SMC	660 Supermoto	03	566 HF	675 HF
SMC	660 Supermoto	04 - 07	706 HF	675 HF
	690 Duke	08 - 11	762 HS	675 LS
	690 Duke ABS	12 - 18	706 HS	675 LS
	690 Duke R	10 - 11	762 HS	675 LS
	690 Duke R	14 - 17	841 HS*	675 LS
	690 Enduro	08 - 14	674 HS	675 LS
	690 Enduro R	09 - 17	674 HS	675 LS
	690 SM	07 - 11	762 HS	675 LS
	690 SMC	08 - 10	762 HS	675 LS
	690 Supermoto R	08 - 09	762 HS	675 LS
	790 Duke	18 -	671 HS*	675 LS
	950 R Superenduro	06 - 08	674 HS	671 LS
	950 SM	05 - 07	762 HS*	671 LS
	950 SM R	07 - 09	762 HS*	671 LS
LC8	950 Adventure	02 - 07	674 HS*	675 LS
	990 Adventure R	10 - 12	674 HS*	671 LS
	990 Adventure,			
	Adventure S, ABS	06 - 11	674 HS*	671 LS
	990 Super Duke	04 - 13	762 HS*	675 LS
	990 Super Duke R	09 - 13	762 HS*	675 LS
	990 Supermoto	07 - 11	762 HS*	671 LS
	990 Supermoto R	10	841 HS*	671 LS
	990 Supermoto T	09 - 13	762 HS*	671 LS
	1050 Adventure	15 - 16	706 SP*	671 LS
	1090 Super Adventure	17 - 18	706 SP*	671 LS
	1090 Super Adventure R	17 - 18	706 SP*	671 LS
	1190 Adventure	13 - 16	706 SP*	671 LS
RC8	1190	08 - 11	841 SP*	730 LS
RC8	1190 R	09 - 15	841 SP*	730 LS
RC8	1190 R Track	11 - 15	841 SP*	730 LS
	1290 Super Adventure	15 - 18	706 SP*	671 LS
	1290 Super Adventure R	17 - 18	706 SP*	671 LS
	1290 Super Adventure S	17 - 18	706 SP*	671 LS
	1290 Super Adventure T	17 - 18	706 SP*	671 LS
	1290 Super Duke GT	16 - 18	901 HS*	730 LS
	1290 Super Duke R	14 - 18	841 HS*	730 LS
<b>KYMCO</b>				
	50 Agility	05 - 08	163 HF	2012
	50 Agility (4T) R10	06 - 14	163 HF	2012



**RECOMMENDED**

1xx = Scooter Pads  
5xx = Street, Off Road & Racing Pads  
2xxx = Brake Shoes



KYMCO				
	50 Agility (4T) R12	06 - 15	163 HF	2012
	50 Agility (4T) R16	06 - 15	154 HF	2203
	50 Agility Basic	07	2012	2012
	50 MXU	05 - 10	2012	749 HF
	50 People	99 - 06	154 HF	2203
	50 Super-8	08 - 16	154 HF	2203
	50 Super-9	00 - 01	144 HF	
	50 Super-9 A/C	02 - 07	119 HF	
	50 Super-9 L/C	02 - 07	119 HF	154 HF
CX	50 Curio Super	94 - 97	121 HF	2057
RS	50 Agility Naked	10 - 15	163 HF	
ZX	50 Super Fever	02 - 06	144 HF	
	125 Agility	06 - 11	163 CT	2012
	125 Agility 16+	14 - 16	154 CT	119 CT
	125 Agility City	11 - 17	163 CT	113 CT
	125 Downtown i	10 - 14	183 CT	204 CT
	125 K-Pipe	13 - 15	688 HF	
	125 Like	11 - 16	163 CT	
	125 New Downtown	16 - 17	159 CT	204 CT
	125 People	01 - 09	154 CT	2203
	125 People GTi	12 - 15	159 CT	204 CT
	125 People One i	14 - 16	154 CT	
	125 Super Dink	10 - 15	183 CT	204 CT
	125 Super-8	08 - 15	154 CT	
	125 Super-9	00 - 01	144 CT	154 CT
S	125 People	05 - 08	154 CT	195 CT
	150 MXU	05 - 17	2012	749 HF
	150 People	01 - 06	154 CT	2203
	150 Quannon	10 - 14	119 CT	119 CT
	200 Agility 16+	14 - 17	154 CT	119 CT
	200 Agility R16	11 - 15	154 CT	119 CT
	200 Downtown i	10 - 15	183 CT	204 CT
	200 Like i	10 - 16	119 CT	119 CT
	200 People GTi	12 - 15	159 CT	204 CT
S	200 People	05 - 07	154 CT	195 CT
	250 MXU	06 - 14	810 SI*	775 SI
	250 People	03 - 12	119 MS	
	250 Super-9	00 - 05	144 CT	154 CT
	250 Urban Quad	06	810 SI*	775 SI
	250 Venox	01 - 14	627 HF	627 HF
	250 Xciting	04 - 05	183 MS	183 MS
	250 Xciting	06 - 09	183 MS	195 MS
KXR	250	04 - 14	810 SI*	775 SI
S	250 People Left/Rear	06 - 08	197 MS	195 MS
S	250 People Right	06 - 08	134 MS	
	300 Downtown i	10 - 15	183 MS	204 MS
	300 Maxxer	06 - 13	810 SI*	775 SI
	300 Maxxer Supermoto	15	810 SI*	775 SI
	300 MXU	06 - 17	810 SI*	810 SI*
	300 People Gti	10 - 13	183 MS	
	300 People GTi	12 - 15	159 MS	204 MS
	300 People Si Left/Rear	08 - 10	163 CT	195 CT
	300 People Si Right	08 - 10	119 CT	
	300 Xciting Ri	08 - 14	183 MS*	195 MS
	350 New Downtown	16 - 17	159 MS	204 MS
	400 Maxxer	08 - 10	822 ATS*	822 ATS
	400 Maxxer (Parking Brake)	08 - 10		921 HF
	400 MXU	08 - 11	822 ATS*	822 ATS
	400 MXU (Parking Brake)	08 - 11		921 HF
	400 Xciting i	12 - 14	214 MS*	212 MS
	450 i Maxxer	10 - 14	822 ATS*	822 ATS
	450 i Maxxer			
	(Parking Brake)	10 - 14		921 HF
	450 i MXU	11 - 14	822 ATS*	822 ATS
	450 i MXU (Parking Brake)	11 - 14		921 HF
	500 MXU	06 - 08	810 SI*	810 SI*
	500 MXU	09 - 14	945 SI*	
	500 MXU DX	11 - 13	945 SI*	

Applications  
Motorcycles, Off Road, ATV/UTV, Scooters

\* = 2 sets required / 2 jeux pour l'Avant.

Full compound selection, see under "Brake pad 1:1 Drawings" / Sélection complète de composés, voir "1:1 Schémas Plaquettes de frein".  
For ABE type approvals, see page 1 / Pour les homologations de type ABE, voir page 2.

**RECOMMENDED**1xx = Scooter Pads  
5xx = Street, Off Road & Racing Pads  
2xxx = Brake Shoes

KYMCO					
	500 UXV 4x4	08 - 14	810 SI*	810 SI	
	500 Xciting	04 - 15	183 MS*	212 MS	
	500 Xciting i Evo ABS	11 - 13	183 MS*	212 MS	
	500 Xciting R ABS	09 - 13	183 MS*	212 MS	
	550 MXU	12 - 15	945 SI*		
	700 MXU	13 - 15	945 SI*		
UXV	700	14 - 16	945 SI*		
LAVERDA					
HP	125 Quasar	04		758 ATS	
HP	180 Quasar	04		758 ATS	
GS	350 Lesmo	86 - 89	519 HF*	519 HF	
	400 Quasar 4x4	04	758 ATS*	758 ATS	
	500 Alpino, S	77 - 83	519 HF*	519 HF	
	500 Quasar 4x4	04	758 ATS*	758 ATS	
	500 Quasar 4x4 C	04	758 ATS*	758 ATS	
OR	600 Atlas	86 - 90	594 HF	519 HF	
SFC	600	86 - 89	506 HF*	506 HF	
	650	92	566 HF*	519 HF	
	650 V-Six	93	506 HS*	506 LS	
	668 668	96 - 97	566 HF	519 HF	
	668 Ghost, Diamante	97	566 HF*	519 HF	
	700 El Cid	90	546 HF	586 HF	
	750 Cup	98 - 01	566 HF*	519 HF	
	750 Diamante	97 - 01	566 HF*	519 HF	
	750 Ghost Strike	97 - 01	566 HF*	519 HF	
	750 S Formula	97 - 01	566 HF*	519 HF	
	750 S, S Carenata	97 - 01	566 HF*	519 HF	
	750 Sport	99 - 01	566 HF*	519 HF	
	750 Strike/Black Strike	99 - 01	566 HF*	519 HF	
	750 T8	98 - 01	566 HF*	519 HF	
TTS	800	99	566 HF*	730 HF	
	1000 Jota	76 - 79	506 HF*	506 HF	
3C	1000 3CE, 3CL	74 - 75	506 HF*	506 HF	
JOTA	1000	95	566 HF	519 HF	
RGS	1000	83	506 HF*	506 HF	
RGS	1000 Jota	86	506 HF*	506 HF	
SFC	1000	04	762 HS*	730 LS	
SFC	1000	85 - 86	506 HF*	506 HF	
TGA	1000 Executive	84	506 HF*	506 HF	
	1200 Mirage	78 - 80	506 HF*	506 HF	
LEM					
	50 CX2, CX3, RX2, RX3	03 - 06	794 RSI	794 RSI	
	50 R2, R3, R3 XC	03 - 06	794 RSI	794 RSI	
RX	65	05 - 10	794 RSI	794 RSI	
RX	150	11		794 RSI	
MAICO					
	all models	89	621 HF	621 HF	
	all models	91	621 HF	586 SI	
	250 Motocross/Enduro	99 - 01	671 SI	675 SI	
GM	250 LC	85	519 SI		
GM	250 Star	86	581 HF	581 HF	
GP	250 all models	89	621 HF	621 HF	
GP	250 E	87	581 HF	581 HF	
GP	250 Motocross	87	581 HF	581 HF	
MD	250	83 - 85	519 SI	519 SI	
	350	93 - 95	621 HF	621 HF	
GP	400 all models	89	621 HF	621 HF	
GP	400 E	87 - 88	581 HF	581 HF	
GP	400 Motocross	87 - 88	581 HF	581 HF	
	500	93 - 94	621 HF	621 HF	
	500 Motocross/Enduro	99	671 SI	675 SI	
	500 Supermotard	99	671 HF	675 HF	
GM	500 LC	85 - 86	519 SI		
GM	500 Star	86	581 HF	581 HF	
GP	500 all models	89	621 HF	621 HF	

**RECOMMENDED**1xx = Scooter Pads  
5xx = Street, Off Road & Racing Pads  
2xxx = Brake Shoes

MAICO					
GP	500 E	87	581 HF	581 HF	
GP	500 Motocross	87	581 HF	581 HF	
GP	550	87	581 HF	581 HF	
MALAGUTI					
	50 Centro	93 - 96	109 HF	2012	
	50 Chopper 25, 40, 80, Fifty	83	532 HF		
	50 Chopper HF, Watercooled	83	532 HF		
	50 Enduro	85 - 87	519 HF		
	50 Enduro Dune	87 - 88	132 HF	132 HF	
	50 Evolution	91	574 HF		
	50 Fifty Evolution	91	559 HF		
	50 Fifty Full, CX, Top	85	595 HF		
	50 Fifty Mistral	90 - 95	595 HF		
	50 Yesterday	97 - 02	123 HF	2012	
CH	50	86	595 HF		
CR-1	50 Crosser	95 - 96	132 HF		
EL	50 Crosser	97 - 00	123 HF		
ES	50 Dune	89	574 HF	574 HF	
F-10	50	92 - 93	113 HF	2012	
F-10	50 Jet-Line	94 - 98	123 HF	2012	
F-12	50 Phantom	94 - 98	132 HF	2012	
F-12	50 Phantom A.C.	99 - 03	123 HF	2012	
F-15	50 Fire Fox	96 - 99	132 HF	2012	
F-15	50 Fire Fox L.C.	96 - 08	109 HF	2012	
MDX	50	86 - 87	574 HF		
MDX	50 Gold Enduro	87	607 HF	596 HF	
MEX	50	86 - 87	541 HF		
MFX	50	86 - 87	541 HF		
MLX	50 Enduro	87	607 HF	596 HF	
MRX	50	89	519 HF		
RCW	50 Ronco	83	532 HF		
RST	50	90	519 HF	519 HF	
RST	50 Sport	87	132 HF	132 HF	
RST	50 Sport	87	574 HF	574 HF	
SL	50 Centro	96	123 HF	2012	
V4	50 Olympique	83	532 HF		
XL	50 Sport	83 - 85	532 HF		
	125 Runner	86	532 HF		
	125 Runner	87	108 CT		
R	125 Madison	99 - 09	120 CT	152 CT	
	250 Madison	99 - 04	159 MS	152 MS	
MGX	425 Ronco	87 - 11	541 HF		
MGX	450 Ronco	87 - 11	595 HF		
MONDIAL					
	1000 EVO	04	762 HS*	730 LS	
	1000 Piegia	03 - 04	762 HS*	730 LS	
	1000 RZ Nuda	04	762 HS*	730 LS	
	1000 Starfighter	04	762 HS*	730 LS	
MONTESA					
	250 Cota 4RT	04 - 16	802 RSI	803 RSI	
Cota	260 4Ride	16 - 18	939 RSI	803 RSI	
Cota	260 4RT	04 - 16	802 RSI	803 RSI	
Cota	260 4RT Race Replica	15 - 18	939 RSI	803 RSI	
Cota	300 RR	16 - 18	939 RSI	803 RSI	
	360 315R	01 - 04	802 RSI	803 RSI	
MORIWAKI					
MD	250	09	782 DC	618 RQ	
MOTO-GUZZI					
	125 Custom	85	519 HF		
	125 Enduro TT	85	519 HF		
BX	125	92	519 HF	519 HF	

\* = 2 sets required / 2 jeux pour l'Avant.





**RECOMMENDED**

1xx = Scooter Pads  
 5xx = Street, Off Road & Racing Pads  
 2xxx = Brake Shoes



MOTO-GUZZI				
	240 /4	77	519 HF	
	250 TS	75 - 76	519 HF	
	350	77 - 81	519 HF*	519 HF
	350 Falco	88	519 HF	519 HF
	350 Imola	78 - 84	519 HF*	519 HF
	350 Nevada	92 - 97	519 HF*	
NTX	350	88	519 HF	519 HF
NTX	350	90	519 HF	506 HF
V35	350 C	82 - 86	506 HF*	519 HF
V35	350 Florida	85 - 86	506 HF*	519 HF
V35	350 GT	77	519 HF	
V35	350 GT	90	506 HF	519 HF
V35	350 II, Imola, Imola II	77	519 HF*	519 HF
V35	350 III	87	506 HF*	506 HF
V35	350 TT	86	506 HF*	506 HF
	400	77 - 84	519 HF*	519 HF
	500	77 - 80	519 HF*	519 HF
	500 Monza	78 - 85	519 HF*	519 HF
V50	500 1,2,3, Monza Chopper	77	519 HF*	519 HF
	650	80 - 84	519 HF*	519 HF
	650 Florida	85 - 84	519 HF*	519 HF
GT	650 Sessantacinque	89	519 HF*	519 HF
NTX	650	90 - 02	519 HF	506 HF
V65	650 Florida	86 - 94	506 HF*	506 HF
V65	650 GT	90 - 94	506 HF	598 HF
V65	650 Lario	86 - 94	519 HF*	519 HF
V65	650 NTX	87 - 02	519 HF	519 HF
V65	650 SP, Chopper	80 - 84	519 HF*	519 HF
V65	650 TT	86 - 94	519 HF*	519 HF
	750 Brevia	03 - 09	706 HS	730 LS
	750 Ippogrifo	97	566 HF	519 HF
	750 Nevada	92 - 96	519 HF*	
	750 Nevada Classic ie	06 - 11	706 HF	730 HF
	750 Nevada, Club/Base	97 - 02	519 HF*	519 HF
	750 Nevada, Nevada Club	03 - 16	706 HF	730 HF
	750 Targa	89	519 HF*	519 HF
NTX	750	89	519 HF	519 HF
NTX	750	90 - 93	596 HS	506 LS
S3	750 Left	75 - 76	506 HF	
S3	750 Right	75 - 76	506 HF	
SP	750	91 - 92	506 HS	506 LS
V7	750 Cafe Classic	10 - 13	706 HS	730 LS
V7	750 Classic	09 - 12	706 HS*	730 LS
V7	750 Clubman Racer	10	706 HS*	730 LS
V7	750 Racer	11	706 HS	730 LS
V7	750 Racer	12 - 14	706 HS	588 HF
V7	750 Stone	12 - 14	706 HS	588 HF
V7 II	750 Racer	15 - 16	706 HS	588 HF
V7 II	750 Scrambler	16	706 HS	588 HF
V7 II	750 Special	15 - 16	706 HS	588 HF
V7 II	750 Stone	15 - 16	706 HS	588 HF
V7 II	750 Stornello	16	706 HS	588 HF
V7 II	750 Stornello Ltd. Edition	17 - 18	706 HS	588 HF
V7 III	750 Anniversario	17 - 18	706 HS	588 HF
V7 III	750 Carbon	18 -	706 HS	588 HF
V7 III	750 Euro 4	17 - 18	706 HS	588 HF
V7 III	750 Milano	18 -	706 HS	588 HF
V7 III	750 Racer	17 - 18	706 HS	588 HF
V7 III	750 Rough	18 -	706 HS	588 HF
V7 III	750 Special	17 - 18	706 HS	588 HF
V7 III	750 Stone	17 - 18	706 HS	588 HF
V75	750	86 - 88	506 HF*	506 HF
V75	750 Duna	86 - 90	506 HF	506 HF
V75	750 TT Paris-Dakar	86	506 HF	506 HF
	850 Le Mans	76 - 79	506 HF*	506 HF
T	850	74 - 76	506 HF	
T3	850	75 - 80	506 HF*	506 HF
T4	850	75 - 82	506 HF*	506 HF



**RECOMMENDED**

1xx = Scooter Pads  
 5xx = Street, Off Road & Racing Pads  
 2xxx = Brake Shoes



MOTO-GUZZI				
T5	850	75 - 88	506 HF*	506 HF
T5	850 N.T.	86 - 88	506 HF*	506 HF
V9	850 Bobber	16 - 17	706 HS	588 HF
V9	850 Roamer	16 - 17	706 HS	588 HF
V9	850 X-Track	17	706 HS	588 HF
	940 Custom	07	706 HS*	674 LS
	1000	81 - 83	554 HF*	554 HF
	1000 California II	85 - 88	506 HF*	506 HF
	1000 California III C	91 - 95	506 HS*	506 LS
	1000 California III, Fuel Injection	89	506 HF*	506 HF
	1000 Daytona	91 - 02	566 HF*	506 HF
	1000 Le Mans IV	85 - 89	506 HF*	506 HF
	1000 Le Mans, V	90 - 98	506 HS*	506 LS
	1000 Quota	92	566 HF*	614 HF
GT	1000 V	91	506 HS*	506 LS
RS	1000 Daytona	97 - 00	566 HF*	519 HF
S	1000	90	506 HS*	506 LS
SP	1000 III	91 - 94	506 HS*	506 LS
SP	1000 Le Mans Left/Rear	79 - 83	506 HF	554 HF
SP	1000 Le Mans Right	79 - 83	506 HF	
V	1000 Strada	93 - 94	506 HF*	519 HF
V10	1000 Centauro	96 - 00	566 HF*	519 HF
	1100 California	96 - 99	506 HS*	506 LS
	1100 California EV	06	706 HS	674 LS
	1100 California EV Touring	06	706 HS	674 LS
	1100 California Jackal	00	566 HF*	674 HF
	1100 California Jackal	01 - 06	706 HS*	674 LS
	1100 California Jackal Basic	00	566 HF	674 HF
	1100 California Jackal Basic	01 - 06	706 HS	674 LS
	1100 California Special	99 - 00	566 HF*	674 HF
	1100 California Special	01	706 HS*	674 LS
	1100 California Special Sport Alloy	02 - 06	706 HS*	674 LS
	1100 California Stone Metal	02 - 03	706 HS	674 LS
	1100 California Stone, Stone Touring	02 - 05	706 HS	674 LS
	1100 California Titanium	03 - 05	706 HS*	674 LS
	1100 California Vintage	06 - 13	706 HS*	674 LS
	1100 Griso	05 - 10	706 HS	674 LS
	1100 Sport	96 - 04	566 HF*	519 HF
ES	1100 Quota	99 - 03	674 HF*	671 HF
EV	1100 California	97 - 00	566 HF*	519 HF
EV	1100 California, 80, Touring	01	706 HS*	519 LS
V	1100 Brevia	04	706 HS	730 LS
V	1100 Brevia, ABS	05 - 07	706 HS	671 LS
V11	1100 , Scura, Sport Scura	02 - 05	706 HS*	519 LS
V11	1100 Lemans, Lemans Tenni, Lemans Rosso Corsa	01 - 06	706 HS*	519 LS
V11	1100 Sport	97 - 00	566 HF*	519 HF
V11	1100 Sport Rosso Mandell	01 - 06	706 HS*	519 LS
V11	1100 Sport, Sport Naked	01 - 05	706 HS*	519 LS
	1200 Griso 8V	07 - 13	706 HS*	671 LS
	1200 Griso 8V SE	18 -	706 HS*	671 LS
	1200 MGS-01 Corsa	05 - 13	762 SP*	730 LS
	1200 Norge	06 - 14	706 HS*	671 LS
	1200 Norge GT 8V	10 - 13	706 HS*	671 LS
	1200 Sport	07 - 08	706 HS*	671 LS
	1200 Sport 4V	09 - 11	706 HS*	730 LS
	1200 Sport 8V	12 - 13	706 HS*	671 LS
	1200 Sport 8V SE	12 - 15	706 HS*	671 LS
	1200 Stelvio	08 - 11	706 SP*	671 LS
	1200 Stelvio 8V SE	12 - 16	706 SP*	671 LS
	1200 Stelvio NTX	09 - 11	706 SP*	671 LS
V	1200 Brevia	08 - 13	706 HS	671 LS
	1400 Audace	15 - 17	706 HS*	674 LS
	1400 California Custom	13 - 15	706 HS*	674 LS

Applications  
Motorcycles, Off Road, ATV/UTV, Scooters

\* = 2 sets required / 2 jeux pour l'Avant.

Full compound selection, see under "Brake pad 1:1 Drawings" / Sélection complète de composés, voir "1:1 Schémas Plaquettes de frein".  
 For ABE type approvals, see page 1 / Pour les homologations de type ABE, voir page 2.

**RECOMMENDED**1xx = Scooter Pads  
5xx = Street, Off Road & Racing Pads  
2xxx = Brake Shoes**MOTO-GUZZI**

	1400 California Touring	13 - 15	706 HS*	674 LS
	1400 California Touring SE	16 - 17	706 HS*	674 LS
	1400 Eldorado	15 - 17	706 HS*	674 LS
MGX-21	1400 Flying Fortress	15 - 17	706 HS*	674 LS

**MOTO-MORINI**

	125 KJ	84 - 88	606 HF	
	125 Strada	80	560 HF	
	250 Strada	80	560 HF	
XE	250 Country	88	519 HF	
	350 Coguaro	90 - 95	608 HF	519 HF
	350 Coguaro, New York	90 - 94	608 HF	519 HF
	350 Dart	88	608 HF	519 HF
	350 Dart	90 - 92	641 HF	519 HF
	350 Excalibur	86	594 HF	594 HF
	350 Excalibur	87 - 89	588 HF	606 HF
	350 Indiana	88	594 HF	519 HF
	350 K2	84 - 87	560 HF	606 HF
	350 Kanguro	88	588 HF	519 HF
	350 Strada	76 - 81	560 HF	
RLX	350 Excalibur	90 - 92	608 HF	519 HF
	400 Dart	89	608 HF	519 HF
	400 Dart	90 - 92	641 HF	519 HF
	400 S	82	519 HF*	519 HF
	500 Sei V Classic	89	519 HF*	
	500 Strada	80 - 82	560 HF	
	501 Camel	88	588 HF	519 HF
	501 Coguaro	89	608 HF	519 HF
	501 Excalibur	86 - 91	594 HF	594 HF
	501 Excalibur	87	588 HF	606 HF
	501 Excalibur	89	594 HF	519 HF
	501 New York	89	594 HF	519 HF
RLX	501 Excalibur	90	608 HF	519 HF
	650 Indiana	88	594 HF	519 HF
	750 Indiana	88	594 HF	519 HF
	1200 11 1/2	18 -	706 HS*	730 LS
	1200 9 1/2	06 - 09	706 HS*	730 LS
	1200 Corsaro	06 - 13	706 HS*	730 LS
	1200 Corsaro ZZ	18 -	901 HS*	730 LS
	1200 Granferro	10	762 HS*	671 LS
	1200 Granpasso	08 - 13	674 HS*	671 LS
	1200 GT	10	674 HS*	671 LS
	1200 Milano	18 -	901 HS*	730 LS
	1200 Scrambler	09 - 10	674 HS*	671 LS
	1200 Scrambler	18 -	901 HS*	730 LS
	1200 Sport	08 - 13	706 HS*	730 LS

**MOTUS**

MST	1650	14 - 17	706 HS*	730 LS
MST-R	1650	14 - 17	841 HS*	730 LS

**MV AGUSTA**

	675 Brutale	12 - 15	706 HS*	730 LS
	675 F3	11 - 12	706 HS*	763 LS
	675 F3	13 - 14	706 HS*	730 LS
	675 F3	15 - 17	901 HS*	730 LS
	675 F3 RC	16 - 17	901 HS*	730 LS
	750 Brutale, Brutale S	01 - 05	676 HS*	763 LS
	750 F4 SPR	01 - 03	676 HS*	763 LS
	750 F4/F4S	99 - 02	676 HS*	763 LS
	800 Brutale	13 - 17	706 HS*	730 LS
	800 Brutale Dragster	15 - 18	706 HS*	730 LS
	800 Brutale Dragster RC	17 - 18	706 HS*	730 LS
	800 Brutale Dragster RR	15 - 18	706 HS*	730 LS
	800 Brutale Dragster RR			
	LH44	18 -	706 HS*	730 LS
	800 Brutale Dragster RR			
	Pirelli	18 -	706 HS*	730 LS

**RECOMMENDED**1xx = Scooter Pads  
5xx = Street, Off Road & Racing Pads  
2xxx = Brake Shoes**MV AGUSTA**

	800 Brutale RC	18 -	706 HS*	730 LS
	800 Brutale RR	16 - 17	706 HS*	730 LS
	800 F3	14 - 17	901 HS*	763 LS
	800 F3 RC	16 - 17	901 HS*	730 LS
	800 Rivale	13 - 17	900 HS*	730 LS
	800 RVS#1	18 -	706 HS*	730 LS
	800 Stradale	15 - 16	900 HS*	730 LS
	800 Turismo Veloce	14 - 16	900 HS*	730 LS
	800 Turismo Veloce Lusso	14 - 16	900 HS*	730 LS
	800 Turismo Veloce RC	17 - 18	900 HS*	730 LS
	910 Brutale	06 - 08	676 HS*	763 LS
	910 Brutale R	06 - 08	676 HS*	763 LS
	910 Brutale S	06 - 08	676 HS*	763 LS
	920 Brutale	12 - 14	706 HS*	763 LS
	989 Brutale R	09	706 HS*	763 LS
	990 Brutale R	10 - 11	706 HS*	763 LS
	1000 F4 LH44	18 -	841 SP*	763 LS
	1000 F4 Mamba	04 - 06	676 HS*	763 LS
	1000 F4 R	06 - 07	762 HS*	763 LS
	1000 F4 R	12 - 15	841 SP*	763 LS
	1000 F4 RC	15 - 18	841 SP*	763 LS
	1000 F4 RR	12 - 17	841 SP*	763 LS
	1000 F4 Tamburini	04 - 06	676 HS*	763 LS
	1000 F4S	04 - 06	676 HS*	763 LS
	1078 Brutale RR	09	841 HS*	763 LS
	1078 F4 CC	08 - 11	841 SP*	763 LS
	1078 F4 RR	08 - 11	841 SP*	763 LS
	1090 Brutale Corse	14 - 16	841 HS*	763 LS
	1090 Brutale R	12 - 15	706 HS*	763 LS
	1090 Brutale RR	10 - 17	841 HS*	763 LS

**MZ**

	660 (MUZ) Baghira	96 - 00	681 HF	684 HF
	660 (MUZ) Black Panther	00 - 06	681 HF	684 HF
	660 (MUZ) Mastiff	96 - 06	681 HF	684 HF
	660 (MUZ) Skorpion Cup	99	566 HF	519 HF
	660 (MUZ) Skorpion			
	Replica	97 - 99	566 HF*	519 HF
	660 (MUZ) Skorpion Sport	95 - 99	566 HF	519 HF
	660 (MUZ) Skorpion Tour	95 - 00	566 HF	519 HF
	660 (MUZ) Skorpion			
	Traveller	99 - 00	566 HF	519 HF
	660 (MUZ) Street Moto	00 - 06	681 HF	684 HF
	660 (MUZ) Super Moto	07	681 HF	684 HF
	1000 (MUZ) S	01 - 02	706 HS*	691 HF
	1000 (MUZ) S	03 - 10	624 HS*	715 LS
	1000 (MUZ) SF	05 - 10	624 HS*	715 LS
	1000 (MUZ) SFX	07	624 HS*	715 LS
	1000 (MUZ) SN	05	624 HS*	715 LS
	1000 (MUZ) ST	07 - 10	624 HS*	715 LS

**NORTON**

	600 Commander	90	506 HF*	506 HF
	600 Interpol	83 - 88	506 HF*	506 HF
	600 Wankel Classic	88 - 89	506 HF*	506 HF
F-1	600	90	566 HF*	506 HF
TT	600	92	566 HF*	
MK2	850 Commando	73 - 75	505 HF	
MK3	850 Commando	75 - 77	505 HF	505 HF
	961 Commando			
	Cafe Racer	11 - 14	762 HS*	730 LS
	961 Commando			
	Cafe Racer MKII	18 -	900 HS*	730 LS
	961 Commando SE	10 - 11	706 HS*	730 LS
	961 Commando SE	12 - 14	762 HS*	730 LS
	961 Commando SF	13 - 15	762 HS*	730 LS
	961 Commando SF Sport	11 - 15	706 HS*	730 LS
	961 Commando Sport	18 -	900 HS*	730 LS

\* = 2 sets required / 2 jeux pour l'Avant.





**RECOMMENDED**

1xx = Scooter Pads  
5xx = Street, Off Road & Racing Pads  
2xxx = Brake Shoes



NORTON				
961	Dominator Naked	17 - 18	900 HS*	730 LS
1200	V4 RR	18 -	841 HS*	730 LS
OSSA				
TR	125 i	15	802 RSI	803 RSI
TR	250 i	15	802 RSI	803 RSI
TR	280 i	10 - 15	802 RSI	803 RSI
TR	280 i Explorer	12 - 15	802 RSI	803 RSI
TR	300 Factory R	15	939 RSI	803 RSI
TR	300 i	15	802 RSI	803 RSI
PEUGEOT				
	e-Vivacity	11 - 15	141 HF	2012
	50 Elyseo	02 - 05	105 HF	105 HF
	50 Elyseo (A.J.P. cal.)	99 - 01	105 HF	2012
	50 Elystar	03 - 05	105 HF	167 HF*
	50 Looxor	02 - 05	105 HF	2012
	50 Looxor	06	105 HF	105 HF
	50 Speedake (A.J.P. cal.)	94 - 01	105 HF	2012
	50 Speedake (Brembo cal.)	94 - 01	123 HF	2012
	50 Speedake (Hengtong cal.)	94 - 01	102 HF	2012
	50 Speedfight 2 A/C	01 - 08	105 HF	
	50 Speedfight 2 L/C	01 - 08	105 HF	105 HF
	50 Speedfight 2 X-Race, Furious, 206 WRC	01 - 02	105 HF	105 HF
	50 Speedfight 3 (AC)	10 - 16	200 HF	2012
	50 Speedfight 3 (LC)	10 - 16	200 HF	157 HF
	50 Speedfight 3 RS (LC)	10 - 16	200 HF	157 HF
	50 Speedfight 4 (AC)	15 - 16	200 HF	
	50 Speedfight 4 (LC)	15 - 16	200 HF	157 HF
	50 Speedfight LBD/LBDP	00	105 HF	105 HF
	50 Speedfight LC, (A.J.P. cal.)	96 - 15	105 HF	2012
	50 Speedfight LC, (Brembo cal.)	96 - 15	123 HF	2012
	50 Speedfight LC, (Hengtong cal.)	96 - 15	102 HF	2012
	50 Speedfight Lemans	11	105 HF	105 HF
	50 Trekker Metal-X	01 - 08	105 HF	
	50 Trekker Offroad	99 - 01	102 HF	
	50 Trekker Road	99 - 00	105 HF	2012
	50 Trekker Streetboard	00 - 02	105 HF	
	50 Trekker Urban Black	00	105 HF	
	50 Vivacity	08 - 14	100 HF	
	50 Vivacity (A.J.P. cal.)	99 - 07	105 HF	
	50 Vivacity (Hengtong cal.)	05 - 07	102 HF	
	50 Vivacity Sportline	11	141 HF	
	100 Elyseo	02 - 05	105 HF	105 HF
	100 Elyseo (A.J.P. cal.)	99 - 01	105 HF	2012
	100 Looxor	02 - 07	105 HF	105 HF
	100 Speedfight	00 - 07	105 HF	105 HF
	100 Speedfight 2, X-Race	01 - 07	105 HF	105 HF
	100 Trekker Road	99 - 04	105 HF	
	100 Vivacity (A.J.P. cal.)	99 - 07	105 HF	
	100 Vivacity (Hengtong cal.)	05 - 07	102 HF	
	125 Elyseo	00 - 07	168 CT	167 CT
	125 Elyseo (A.J.P. cal.)	99	105 CT	
	125 Elystar	03 - 07	168 CT	167 CT
	125 Looxor	03 - 07	156 CT	167 CT
	125 Vivacity	10 - 16	197 CT	
	150 Elyseo	00 - 04	168 CT	167 CT
	150 Elystar	03 - 04	168 CT	167 CT



**RECOMMENDED**

1xx = Scooter Pads  
5xx = Street, Off Road & Racing Pads  
2xxx = Brake Shoes



PIAGGIO VESPA				
	50 New Liberty S	16 - 18	101 HF	
	50 Primavera	14 - 17	177 HF	
	50 Sprint	15 - 17	177 HF	
	50 Typhoon	06 - 14	101 HF	
TPH	50 2T	11 - 17	177 HF	
	100 Fly	07 - 15	177 HF	2205
	100 Zip	07 - 10	177 HF	2205
	125 946	14 - 16	177 CT	166 CT
	125 Liberty iGet 4T 3V	17 - 18	228 CT	
	125 Medley	16 - 18	228 CT	187 CT
	125 Medley S	17 - 18	228 CT	187 CT
	125 MP3	06 - 07	202 CT*	191 CT
	125 MP3 (Parking Brake)	06 - 07		209 HF
	125 MP3 Efi	08 - 11	202 CT*	187 CT
	125 MP3 Efi (Parking Brake)	08 - 11		209 HF
	125 MP3 Hybrid	09 - 12	202 CT*	187 CT
	125 MP3 Hybrid (Parking Brake)	09 - 12		209 HF
	125 MP3 Yourban	11 - 12	202 CT*	187 CT
	125 MP3 Yourban (Parking Brake)	11 - 12		209 HF
	125 New Liberty	16 - 18	228 CT	
	125 Primavera	14 - 16	177 CT	
	125 Primavera 70	16	177 CT	
	125 Sprint	16 - 17	177 CT	
	125 Sprint S	17	177 CT	
	125 Sprint Sport	17	177 CT	
	150 Fly	06 - 07	177 CT	2205
	150 Medley	16 - 18	228 CT	187 CT
	150 Primavera	14 - 17	177 CT	
	150 X8 Street	06 - 08	177 CT	
	250 MP3	06 - 07	202 MS*	191 MS
	250 MP3 (Parking Brake)	06 - 07		209 HF
	250 MP3 Efi	08 - 09	202 MS*	187 MS
	250 MP3 Efi (Parking Brake)	08 - 09		209 HF
	250 MP3 LT iE	09	202 MS*	187 MS
	250 MP3 LT iE (Parking Brake)	09		209 HF
	300 MP3 Hybrid	11 - 12	202 MS*	187 MS
	300 MP3 Hybrid (Parking Brake)	11 - 12		209 HF
	300 MP3 Hybrid iE	11 - 18	202 MS*	187 MS
	300 MP3 Hybrid iE (Parking Brake)	11 - 18		209 HF
	300 MP3 iE	10 - 18	202 MS*	187 MS
	300 MP3 iE (Parking Brake)	10 - 18		209 HF
	300 MP3 LT	13 - 18	202 MS*	187 MS
	300 MP3 LT (Parking Brake)	13 - 18		209 HF
	300 MP3 LT Business	13 - 18	202 MS*	187 MS
	300 MP3 LT Business (Parking Brake)	13 - 18		209 HF
	300 MP3 LT iE ABS	14 - 18	224 MS*	187 MS
	300 MP3 LT iE ABS (Parking Brake)	14 - 18		209 HF
	300 MP3 LT Sport ABS	14 - 18	224 MS*	187 MS
	300 MP3 LT Sport ABS (Parking Brake)	14 - 18		209 HF
	300 MP3 LT Touring	11 - 12	202 MS*	187 MS
	300 MP3 LT Touring (Parking Brake)	11 - 12		209 HF
	300 MP3 Touring	11 - 12	202 MS*	187 MS
	300 MP3 Touring (Parking Brake)	11 - 12		209 HF
	300 MP3 Yourban iE	11 - 18	202 MS*	187 MS
	300 MP3 Yourban iE (Parking Brake)	11 - 18		209 HF

\* = 2 sets required / 2 jeux pour l'Avant.

**RECOMMENDED**1xx = Scooter Pads  
5xx = Street, Off Road & Racing Pads  
2xxx = Brake Shoes

PIAGGIO VESPA				
BV	350 Beverly S	14 - 18	177 MS	187 MS
	350	12 - 17	177 MS	187 MS
	400 MP3 iE	07 - 10	202 MS*	177 MS
	400 MP3 iE (Parking Brake)	07 - 10		209 HF
	400 MP3 LT iE	09 - 10	202 MS*	177 MS
	400 MP3 LT iE (Parking Brake)	09 - 10		209 HF
	400 MP3 LT Touring	11 - 12	202 MS*	177 MS
	400 MP3 LT Touring (Parking Brake)	11 - 12		209 HF
	400 MP3 Touring	11 - 12	202 MS*	177 MS
	400 MP3 Touring (Parking Brake)	11 - 12		209 HF
	500 MP3	10	202 MS*	177 MS
	500 MP3 (Parking Brake)	10		209 HF
	500 MP3 LT Touring			
	500 Business	11 - 13	202 MS*	177 MS
	500 MP3 LT Touring Business (Parking Brake)	11 - 13		209 HF
	500 MP3 LT Touring Business ABS	14 - 15	224 MS*	177 MS
	500 MP3 LT Touring Business ABS (Parking Brake)	14 - 15		209 HF
	500 MP3 LT Touring Sport	11 - 13	202 MS*	177 MS
	500 MP3 LT Touring Sport (Parking Brake)	11 - 13		209 HF
	500 MP3 LT Touring Sport ABS	14 - 15	224 MS*	177 MS
	500 MP3 LT Touring Sport ABS (Parking Brake)	14 - 15		209 HF
	500 MP3 Touring Business	11 - 12	202 MS*	177 MS
	500 MP3 Touring Business (Parking Brake)	11 - 12		209 HF
	500 MP3 Touring Sport	11 - 12	202 MS*	177 MS
	500 MP3 Touring Sport (Parking Brake)	11 - 12		209 HF
POLARIS				
	EV-LSV	10 - 11	897 ATS*	800 ATS
	LSV 4x4	11 - 12	897 ATS*	800 ATS
	Ranger 48v EV	13 - 18	897 ATS*	800 ATS
	50 Predator	04 - 14	2048	
	50 Scrambler	01 - 03	2048	
	90 Predator	03 - 14	2043	
	90 Scrambler	01 - 03	2048	
	90 Sportsman	01 - 15	2048	
	170 Ranger RZR	09 - 18	905 SI*	906 SI
	200 Phoenix	05 - 09	544 ATS*	546 SI
	200 Phoenix	10 - 14	905 SI*	546 SI
	200 Sawtooth	06 - 07	544 ATS*	544 ATS
	250 2x4, 4x4	90 - 93	716 ATS*	717 ATS
	250 Big Boss 4x6, 6x6	89 - 93	716 ATS*	717 ATS
	250 Big Boss 4x6, 6x6 Middle Axle Brake	89 - 93	717 ATS	
	250 Cyclone	87	2028	643 HF
	250 Trail Blazer	90 - 98	716 ATS*	717 ATS
	250 Trail Blazer	99 - 07	716 ATS*	755 ATS
	250 Trail Boss	88 - 90	642 ATS*	643 HF
	250 Trail Boss	91 - 99	716 ATS*	717 ATS
	250 Trail Boss 2x4, 4x4	91 - 92	716 ATS*	717 ATS
	250 Xplorer 4x4	00 - 02	716 ATS*	755 ATS
	300 2x4, 4x4	94 - 95	716 ATS*	717 ATS
	300 Big Boss 6x6	94	716 ATS*	717 ATS
	300 Big Boss 6x6 Middle Axle Brake	94	717 ATS	
	300 Hawkeye 2x4, 4x4	06	822 ATS*	822 ATS

**RECOMMENDED**1xx = Scooter Pads  
5xx = Street, Off Road & Racing Pads  
2xxx = Brake Shoes

POLARIS				
	300 Hawkeye 2x4, 4x4	07 - 11	716 ATS*	716 ATS
	300 Sportsman 4x4	08 - 11	642 ATS*	642 ATS
	300 Xplorer 4x4	96 - 99	716 ATS*	717 ATS
	300 Xpress 2x4	98 - 99	716 ATS*	717 ATS
	300 Xpress L	96 - 97	716 ATS*	717 ATS
	325 Magnum 2x4, 4x4	00 - 02	716 ATS*	755 ATS
	325 Trail Boss	00 - 02	716 ATS*	755 ATS
	325 Xpedition	00 - 01	642 ATS*	755 ATS
	325 Xpedition	02	642 ATS*	787 ATS
	330 ATP	04 - 05	716 ATS*	716 ATS*
	330 ATP	06 - 05	716 ATS*	787 ATS
	330 E Trail Blazer	08 - 12	642 ATS*	787 ATS
	330 Magnum 2x4, 4x4	03 - 13	716 ATS*	787 ATS
	330 Trail Boss	03 - 14	716 ATS*	755 ATS
	335 Sportsman 4x4	99 - 02	716 ATS*	755 ATS
	350 Big Boss	93	716 ATS*	717 ATS
	350 Big Boss Middle Axle Brake	93	717 ATS	
	350 L 2x4, 4x4	90	716 ATS*	717 ATS
	350 L 4x4	93	716 ATS*	717 ATS
	350 Sportsman 4x4	93	716 ATS*	717 ATS
	350 Trail Boss 2x4	85 - 87	2028	
	350 Trail Boss 2x4, 4x4	88 - 89	716 ATS*	717 ATS
	350 Trail Boss L 2x4	91 - 93	716 ATS*	717 ATS
	350 Trail Boss L 4x4	91	716 ATS*	717 ATS
	400 Big Boss L 6x6	96	716 ATS*	717 ATS
	400 Big Boss L 6x6 Middle Axle Brake	96	756 ATS	
	400 L 2x4	94 - 95	716 ATS*	717 ATS
	400 L 4x4	94	716 ATS*	717 ATS
	400 Scrambler 2x4, 4x4	00 - 03	716 ATS*	755 ATS
	400 Scrambler 4x4	98	716 ATS*	717 ATS
	400 Scrambler 4x4	99 - 03	716 ATS*	755 ATS
	400 Scrambler L 4x4	95 - 97	716 ATS*	717 ATS
	400 Sport	99 - 00	716 ATS*	755 ATS
	400 Sport L	94 - 98	716 ATS*	717 ATS
	400 Sportsman	01 - 13	716 ATS*	755 ATS
	400 Sportsman L 4x4	94 - 97	716 ATS*	717 ATS
	400 Trail Blazer	03 - 04	716 ATS*	755 ATS
	400 Xplorer L 4x4	95 - 99	716 ATS*	717 ATS
	400 Xplorer L 4x4	00 - 02	716 ATS*	755 ATS
	400 Xpress L	96 - 97	716 ATS*	717 ATS
	425 2x4, 4x4 Magnum	95 - 98	716 ATS*	717 ATS
	425 Magnum 6x6	96	716 ATS*	717 ATS
	425 Magnum 6x6 Middle Axle Brake	96	756 ATS	
	425 Xpedition 4x4	00 - 03	716 ATS*	755 ATS
	450 Outlaw MXR	09 - 11	898 ATS*	642 ATS
	450 Outlaw S	08	898 ATS*	642 ATS
	450 Sportsman	06 - 09	716 ATS*	787 ATS
	455 Diesel EBS 4x4	99 - 01	716 ATS*	755 ATS
	500 ATP HO	04 - 05	716 ATS*	716 ATS*
	500 Big Boss 6x6	98 - 99	716 ATS*	717 ATS
	500 Big Boss 6x6 Middle Axle Brake	98 - 99	717 ATS	
	500 E Scrambler 2x4, 4x4	08 - 11	642 ATS*	787 ATS
	500 Magnum 2x4, 4x4	02 - 07	716 ATS*	787 ATS
	500 Magnum 4x4	00 - 01	716 ATS*	755 ATS
	500 Outlaw	06 - 09	716 ATS*	716 ATS
	500 Predator	03 - 13	716 ATS*	716 ATS
	500 Predator e	06 - 13	716 ATS*	787 ATS
	500 Ranger 2x4	08 - 07	897 ATS*	800 ATS
	500 Ranger 2x4 EFi	08 - 13	897 ATS*	800 ATS
	500 Ranger 2x4, 4x4, 6x6	02 - 13	800 ATS*	800 ATS*
	500 Ranger 4x4	12 - 13	897 ATS*	800 ATS
	500 Ranger 6x6	00 - 02	716 ATS*	
	500 Ranger XP	06 - 09	800 ATS*	800 ATS
	500 Revolver	06	642 ATS*	642 ATS

\* = 2 sets required / 2 jeux pour l'Avant.





**RECOMMENDED**

1xx = Scooter Pads  
 5xx = Street, Off Road & Racing Pads  
 2xxx = Brake Shoes



**RECOMMENDED**

1xx = Scooter Pads  
 5xx = Street, Off Road & Racing Pads  
 2xxx = Brake Shoes



POLARIS				
500 Scrambler 2x4	01 - 02	716 ATS*	755 ATS	
500 Scrambler 4x4	97	716 ATS*	717 ATS	
500 Scrambler 4x4	98 - 13	716 ATS*	755 ATS	
500 Sportsman 4x4	96 - 14	716 ATS*	717 ATS	
500 Sportsman 6x6	00 - 11	716 ATS*	757 ATS	
500 Sportsman EBS 4x4	98 - 02	716 ATS*	755 ATS	
500 Sportsman HO (from 16.12.2008)	09 - 14	642 ATS*	899 ATS	
500 Sportsman HO (to 15.12.2008)	03 - 08	642 ATS*	787 ATS	
500 Xplorer 4x4	97	716 ATS*	717 ATS	
525 Outlaw	07 - 13	898 ATS*	642 ATS	
525 Outlaw IRS	08 - 13	898 ATS*	642 ATS	
525 Outlaw S	08 - 11	898 ATS*	642 ATS	
550 Sportsman	11 - 14	899 ATS*	899 ATS	
550 Sportsman EPS	10 - 14	899 ATS*	899 ATS	
550 Sportsman EPS X2	14	899 ATS*	899 ATS	
550 Sportsman Touring EPS	10 - 12	899 ATS*	899 ATS	
550 Sportsman X2	10 - 14	899 ATS*	899 ATS	
550 Sportsman XP	09 - 12	899 ATS*	899 ATS	
550 Sportsman XP EPS	09 - 14	899 ATS*	899 ATS	
550 Sportsman XP Touring EPS	12 - 14	899 ATS*	899 ATS	
570 Ranger RZR EFi	12 - 13	898 ATS*	642 ATS	
600 Sportsman	03 - 06	642 ATS*	787 ATS*	
700 MVRs 4x4	08	897 ATS*	897 ATS	
700 Ranger 4x4 EFi	08	897 ATS*	800 ATS	
700 Ranger 6x6 EFi	12 - 13	897 ATS*	800 ATS	
700 Sportsman	02 - 09	642 ATS*	787 ATS*	
700 Sportsman MV 700	05 - 06	642 ATS*	787 ATS	
800 MVRs 4x4	08	897 ATS*	897 ATS	
800 Ranger 4x4 EFi	10	897 ATS*	897 ATS	
800 Ranger 6x6 EFi	12 - 15	897 ATS*	897 ATS	
800 Ranger Crew	12 - 15	897 ATS*	897 ATS	
800 Ranger RZR EFi	08 - 14	898 ATS*	642 ATS	
800 Ranger RZR S EFi	09 - 15	898 ATS*	642 ATS	
800 Ranger RZR4 EFi	12 - 14	897 ATS*	800 ATS	
800 Ranger XP	12 - 13	897 ATS*	800 ATS	
800 RZR	08 - 15	898 ATS*	642 ATS	
800 RZR-4	10 - 14	897 ATS*	800 ATS	
800 Sportsman (from 16.12.2008)	09 - 14	642 ATS*	899 ATS	
800 Sportsman (to 15.12.2008)	05 - 08	642 ATS*	787 ATS	
850 Forest	15	899 ATS*	899 ATS	
850 Scrambler	15	899 ATS*	899 ATS	
850 Scrambler HO EPS	13 - 15	899 ATS*	899 ATS	
850 Scrambler MD	15	899 ATS*	899 ATS	
850 Scrambler XP HO EPS	14 - 15	899 ATS*	899 ATS	
850 Sportsman	11 - 13	899 ATS*	899 ATS	
850 Sportsman MV	12	899 ATS*	899 ATS	
850 Sportsman Touring	14 - 15	899 ATS*	899 ATS	
850 Sportsman Touring EPS	10 - 13	899 ATS*	899 ATS	
850 Sportsman Touring HO EPS	13 - 14	899 ATS*	899 ATS	
850 Sportsman Touring MD	15	899 ATS*	899 ATS	
850 Sportsman X2	11	899 ATS*	899 ATS	
850 Sportsman XP	09 - 14	899 ATS*	899 ATS	
850 Sportsman XP EPS	09 - 14	899 ATS*	899 ATS	
850 Sportsman XP HO EPS	13 - 14	899 ATS*	899 ATS	
850 Sportsman XP HO EPS MD	15	899 ATS*	899 ATS	
850 Sportsman XP Touring EPS	15	899 ATS*	899 ATS	
900 Ranger 4x4 Diesel	10 - 14	897 ATS*	897 ATS	



POLARIS				
900 Ranger RZR4 XP EFi	12 - 15	897 ATS*	897 ATS	
900 Ranger RZR4 XP4 EFi	12 - 14	897 ATS*	897 ATS	
1000 Forest	15	899 ATS*	899 ATS	
1000 General EPS	16 - 18	897 ATS*	898 ATS	
1000 Ranger RZR XP	14	897 ATS*	897 ATS	
1000 Scrambler MD	15 - 18	899 ATS*	899 ATS	
1000 Scrambler XP	15 - 18	899 ATS*	899 ATS	
1000 Scrambler XP HO EPS	14	899 ATS*	899 ATS	
1000 Sportsman MD	15 - 18	899 ATS*	899 ATS	
1000 Sportsman Touring	15 - 18	899 ATS*	899 ATS	
1000 Sportsman XP	15 - 18	899 ATS*	899 ATS	
1050 MV Diesel Crew	13 - 18	897 ATS*	897 ATS	

POLINI				
X1 50 R	04 - 06	794 RSI	794 RSI	
X3 50 R	04 - 06	794 RSI	794 RSI	
X5 65 RP	05 - 06	794 RSI	794 RSI	

REWACO				
FX4	07	519 HF		
FX5	07	519 HF		
FX6	07	519 HF		
HS4	01	519 HF		
HS5	01	519 HF		
HS6	01	519 HF		
RF1	07 - 14	519 HF		

ROYAL ENFIELD				
535 Continental GT	14 - 17	674 HS	675 LS	

SACHS				
50 MadAss	04 - 05	200 HF		
50 MadAss 4T	05 - 09	200 HF	100 HF	
125 MadAss	09	200 HF	100 HF	
500 MadAss	05 - 08	566 HF*	684 HF	

SCORPA				
SY 115 F Trial	06	802 RSI	803 RSI	
TY-S 115 F Trial	06	559 HF	803 RSI	
125 Twenty Trial	16 - 18	802 RSI	803 RSI	
SY 125 F Trial	06 - 11	802 RSI	803 RSI	
TY-S 125 F Trial	06 - 08	559 HF	803 RSI	
250 T-Ride	08 - 11	859 HF	773 HF	
250 Twenty Trial	16 - 18	802 RSI	803 RSI	
SY 250 F Trial	06 - 11	802 RSI	803 RSI	
SY 250 Trial	00 - 01	802 RSI	803 RSI	
300 Twenty Trial	16 - 18	802 RSI	803 RSI	

SHERCO				
50 AJP Caliper incl. pin/spring	91 - 18	188 HF		
80 0.8	01 - 03	559 HF	559 HF	
ST 80 (Formula cal.)	13 - 14	885 RSI	803 RSI	
SE-R 125	17	671 SI	791 SI	
ST 125 (Formula cal.)	13 - 14	885 RSI	803 RSI	
ST 125 1.25	01 - 05	559 HF	559 HF	
ST 125 1.25	06 - 11	802 RSI	803 RSI	
ST 200 2.0	01	559 HF	559 HF	
SE 250 , R	14	671 SI	791 SI	
SE 250 2.5i Enduro	06 - 11	671 SI	790 SI	
SE 250 F, F-R	14 - 18	671 SI	791 SI	
SE 250 i/IR	12 - 13	671 SI	791 SI	
SE 250 i-F	13	671 SI	791 SI	
ST 250 (Formula cal.)	13 - 14	885 RSI	803 RSI	
ST 250	99 - 00	559 RSI	559 RSI	
ST 250 2.5	01	802 RSI	803 RSI	
SX 250 2.5i-F	09 - 11	671 RSI	790 RSI	
ST 290 (Formula cal.)	13 - 14	885 RSI	803 RSI	

\* = 2 sets required / 2 jeux pour l'Avant.

Full compound selection, see under "Brake pad 1:1 Drawings" / Sélection complète de composés, voir "1:1 Schémas Plaquettes de frein".  
 For ABE type approvals, see page 1 / Pour les homologations de type ABE, voir page 2.

**RECOMMENDED**1xx = Scooter Pads  
5xx = Street, Off Road & Racing Pads  
2xxx = Brake Shoes

SHERCO				
ST	290 2.9	01	802 RSI	803 RSI
SCF-R	300	16 - 18	671 SI	791 SI
SE	300 , R	14 - 18	671 SI	791 SI
SE	300 3.0i-F	10 - 11	671 SI	790 SI
SE	300 F, F-R	14 - 18	671 SI	791 SI
SE	300 i/R	12 - 13	671 SI	791 SI
SE	300 i-F	13	671 SI	791 SI
ST	300	16 - 18	802 RSI	803 RSI
ST	305 (Formula cal.)	13 - 14	885 RSI	803 RSI
ST	320 3.2F	05	802 RSI	803 RSI
SE	450 4.5i Enduro	04	671 SI	604 SI
SE	450 4.5i Enduro	05 - 11	671 SI	790 SI
SE	450 F, F-R	14 - 18	671 SI	791 SI
SE	450 iR	12 - 13	671 SI	791 SI
SM	450 4.5i Supermotard	06	762 RS	790 RSI
SE	510 5.1i Enduro	06 - 11	671 SI	790 SI
SE	510 iR	12 - 13	671 SI	791 SI
SUZUKI				
RE	5M, A	75 - 77	503 HF	2098
AH	50 Adress	92 - 95	101 HF	2181
ALT	50	83 - 84		2020
FA	50	80 - 91	2101	2101
GSXR	50	87	135 HF	2017
JR	50	89 - 07	2020	2020
LT	50	84 - 02		2020
LT-A	50 Quadmaster	01 - 05	2101	2017
LT-Z	50 Quadsport	06 - 17	2101	2017
OR	50	79	2015	2015
OR	50 E	80	135 HF	2017
RG	50 GAG	87 - 92	135 HF	2103
RG	50 Gamma	90 - 96	135 HF	2103
RM	50	78 - 80	2015	2015
RM	50	81 - 82	2017	2017
ZR	50	81 - 87	135 HF	2017
ZZ	50 Scooter	92	101 HF	2181
RM	60	03	2093	2093
RM	65	03 - 06	752 RSI	536 RSI
DR-Z	70	08 - 18	2010	2010
AH	80 Adress, V, Tune	88 - 91	101 HF	2181
AH	80 Scooter	92 - 94	102 HF	2181
DS	80	80 - 96	2017	2017
JR	80	01 - 07	2017	2017
LT	80	87 - 06	2101	2104
RM	80	77 - 79	2015	2015
RM	80	80 - 81	2017	2017
RM	80	82 - 85	2022	2182
RM	80	83 - 85	2014	2017
RM	80	86 - 89	548 HF	2182
RM	80	90 - 95	548 HF	544 SI
RM	80	96 - 01	702 RSI	544 RSI
RM	85 , L	02 - 04	702 RSI	544 RSI
RM	85 , L	05 - 18	726 RSI	820 RSI
LT-Z	90 Quadsport	07 - 14	2017	2104
RV	90	73 - 81	2015	2015
TS	90	71 - 73	2015	2014
AH	100 V Adress	91 - 94	101 HF	2181
DR	100	83 - 90	2017	2017
RM	100	76 - 78	2015	2014
RM	100	79 - 81	2015	2103
RM	100	03	726 RSI	592 RSI
	110 Smash	03 - 06	2015	2015
DR-Z	110	02 - 06	2093	2015
FX	110 Shogun	98 - 02	2015	2015
UK	110 Adress	15 - 18	101 HF	
ALT	125	84 - 86		2016
ALT	125 D	83		2107
DR	125	82 - 84	2014	2014

**RECOMMENDED**1xx = Scooter Pads  
5xx = Street, Off Road & Racing Pads  
2xxx = Brake Shoes

SUZUKI				
DR	125	86 - 02	536 HF	2014
DR-Z	125 K	03 - 12	2017	2017
DR-Z	125 L	03 - 18	702 SI	2017
GN	125	82 - 90	585 HF	2014
GN	125	91 - 04	546 HF	2014
GN	125	05 - 10	585 HF	2014
GS	125 ESD	83 - 94	585 HF	2014
GT	125	75 - 78	503 HF	2014
LT	125 D	83		2107
LT	125 E-H	84 - 87		2016
RH	125 X	87	536 HF	
RM	125	75 - 78	2014	2014
RM	125	79 - 80	2014	2103
RM	125	81 - 83	2014	2102
RM	125	84	2108	2102
RM	125	85 - 86	581 HF	2102
RM	125	87	611 SI	2102
RM	125	88	611 RSI	584 RSI
RM	125	89 - 90	611 RSI	632 RSI
RM	125	91 - 95	611 RSI	648 RSI
RM	125	96 - 09	694 RSI	604 RSI
RV	125 VanVan	03 - 18	704 HF	
SP	125	82 - 83	2014	2014
SP	125	86 - 88	536 HF	2014
TS	125	72	2015	2014
TS	125	73 - 81	2014	2014
UC	125 Epicuro	99 - 02	122 CT	2202
UE	125	01 - 03	101 CT	
UH	125 Burgman	07 - 18	192 CT	196 CT
UE	150 CT	02 - 03	101 CT	
LT	160	89 - 92	2181	2016
LT-F	160	91 - 04	2181	2016
PE	175	82	2104	
ALT	185	85 - 87		2016
GT	185	75 - 77	503 HF	2014
LT	185	84 - 87		2016
TS	185	74 - 81	2014	2014
DR	200	86 - 88	536 SI	2014
DR	200 S	15 - 17	536 SI	2014
DR	200 SE	96 - 13	536 SI	2014
DR	200 T	96	536 SI	2014
RV	200 VanVan	16 - 18	704 HF	
SP	200	86 - 88	536 HF	2014
UH	200	07	192 CT	
UH	200 Burgman	07 - 13	192 CT	196 CT
UH	200 Burgman	14 - 18	134 CT	196 CT
LT	230	85 - 86	2051	2016
LT	230	85 - 88	591 SI*	584 SI
LT	230	86 - 93	591 SI*	592 SI
LT-F	230	86 - 87	2051	2016
AN	250 Burgman	98 - 03	146 MS	125 MS
AN	250 Burgman	04 - 06	146 MS	174 MS
DL	250 V-Strom	17 - 18	627 HF	657 HF
DR	250	82 - 83	2014	2014
DR	250	85 - 89	536 HF	2014
DR	250	90 - 95	611 HF	632 HF
DR-Z	250	01 - 07	694 SI	648 SI
GN	250	86 - 97	533 HF	2014
GS	250	80 - 82	533 HF	2018
GSX-R	250	17 - 18	627 HF	657 HF
GT	250	73 - 78	503 HF	2097
GW	250 Inazuma	12 - 18	627 HS	657 LS
GW	250 Inazuma F	15 - 18	627 HS	657 LS
LT	250	85 - 86	2051	2098
LT	250	85 - 87	591 SI*	584 SI
LT	250	88 - 94	591 SI*	649 SI
LT	250	89 - 90	591 SI*	592 SI
LT	250 4WD	87 - 98	2053	2110

\* = 2 sets required / 2 jeux pour l'Avant.





**RECOMMENDED**

1xx = Scooter Pads  
5xx = Street, Off Road & Racing Pads  
2xxx = Brake Shoes



SUZUKI					
LT-F	250	88 - 01	2053		2110
LT-F	250 4WD V, W Quadrunner	97 - 98	2053		2098
LT-F	250 Ozark	03 - 13	536 SI*		
LT-Z	250 Quad Sport	04 - 11	536 SI*		
RH	250	85 - 87	536 HF		
RM	250	76 - 78	2014		2016
RM	250	79	2016		
RM	250	80	2104		
RM	250	81 - 82	2107		2102
RM	250	83	2108		2102
RM	250	84	2108		2104
RM	250	85	581 HF		2104
RM	250	86	582 HF		2104
RM	250	87 - 88	611 RSI		584 RSI
RM	250	89 - 90	611 RSI		632 RSI
RM	250	91 - 95	611 RSI		648 RSI
RM	250	96 - 09	694 RSI		604 RSI
RMX	250	89 - 95	611 RSI		648 RSI
RMX	250	96 - 98	694 RSI		648 RSI
RMX	250 X-K1	99	694 SI		604 SI
RM-Z	250	04 - 09	694 RSI		790 RSI
RM-Z	250 Efi	10 - 18	694 RSI		790 RSI
SP	250	85	536 HF		2014
TS	250	74 - 82	2016		2016
TU	250 X	09 - 18	705 HF		
LT-F	280 4WD	91 - 98			2052
GS	300	82 - 85			2018
LT	300	87 - 89	2051		2098
LT-F	300	88 - 90	2051		2052
LT-F	300 King Quad	91 - 01			2052
LT-F	300 King Quad Left/Rear	02	611 SI		2052
LT-F	300 King Quad Right	02	638 SI		
DR	350	90 - 99	611 HF		648 HF
DR	350 V, W, X	97 - 99	694 SI		648 SI
SP	370	77 - 79	2016		2016
GT	380	73 - 77	503 HF		2097
GT	380 Asco	77	515 HF		2097
AN	400 Burgman	99 - 00	146 MS		125 MS
AN	400 Burgman	01 - 06	146 MS		174 MS
AN	400 Burgman Left/Rear	07 - 18	197 MS		182 MS
AN	400 Burgman Right	07 - 18	134 MS		
DR-Z	400 S/E	00 - 12	694 HF		604 HF
DR-Z	400 SM	05 - 10	694 RSI		604 RSI
GN	400	80	533 HF		2018
GS	400	77 - 78	511 HF		2097
GS	400	78 - 82	515 HF		2097
GSF	400 Bandit	91 - 92	597 HS*		556 LS
KLT-A	400 King Quad Left	08 - 14	835 SI		
KLT-A	400 King Quad Right	08 - 14	836 SI		
KLT-F	400 King Quad Left	08 - 14	835 SI		
KLT-F	400 King Quad Right	08 - 14	836 SI		
LT-A	400 Eiger 2WD/4WD	02 - 07	536 SI*		2018
LT-A	400 King Quad Left	08 - 14	835 SI		
LT-A	400 King Quad Right	08 - 14	836 SI		
LT-F	400 Eiger 2WD/4WD	02 - 07	536 SI*		2018
LT-F	400 King Quad Left	08 - 14	835 SI		
LT-F	400 King Quad Right	08 - 14	836 SI		
LT-Z	400 Quad Sport	02 - 15	592 SI*		649 SI
PE	400	79 - 81	2016		2016
RM	400	78	2014		2016
RM	400	79	2016		
RM	400	80	2104		
SP	400	80 - 82	2016		2016
GS	425	79	511 HF		2018
GS	425	80	515 HF		2018
GS	450	80 - 83	533 HF		2018
GS	450	85	534 HF		2018
GS	450	86	546 HF*		512 HF



**RECOMMENDED**

1xx = Scooter Pads  
5xx = Street, Off Road & Racing Pads  
2xxx = Brake Shoes



SUZUKI					
GS	450	90	597 HS		597 LS
LT-A	450 King Quad Left	08 - 14	835 SI		
LT-A	450 King Quad Right	08 - 14	836 SI		
LT-R	450 Left/Rear	06 - 12	611 SI		649 SI
LT-R	450 Right	06 - 12	638 SI		
RMX	450 Z Efi	10	694 SI		790 SI
RMX	450 Z Efi	17 - 18	694 SI		790 SI
RM-Z	450	05 - 07	694 RSI		790 RSI
RM-Z	450 Efi	08 - 17	694 RSI		790 RSI
RM-Z	450 Efi	18 -	694 RSI		790 RSI
RM	465	81 - 82	2107		2014
GS	500	89 - 95	597 HS		556 LS
GS	500	96 - 03	704 HS		556 LS
GS	500	04 - 08	704 HS		556 HF
GS	500 F	04 - 08	704 HS		556 HF
GT	500	73 - 75	515 HF		2098
GT	500	75 - 77	503 HF		2098
LT	500	87 - 95	591 SI*		649 SI
LT-A	500 F Vinson	02	536 SI*		
LT-A	500 FY Quadmaster Left	00 - 08	611 SI		
LT-A	500 FY Quadmaster Right	00 - 08	638 SI		
LT-A	500 King Quad Left	11 - 14	835 SI		
LT-A	500 King Quad Right	11 - 14	836 SI		
LT-F	500 F Left	98 - 07	638 SI		
LT-F	500 F Right	98 - 07	611 SI		
RM	500	83 - 84	2108		2014
RM	500	85 - 87	581 HF		2014
RM	500	87 - 89	611 RSI		592 RSI
GS	550	77	515 HF*		2099
GS	550	77 - 79	515 HF*		512 HF
GS	550	80 - 84	534 HF*		512 HF
GS	550	83 - 86	556 HF		556 HF
GT	550	73 - 77	503 HF		2098
GT	550	78	515 HF		2099
GSF	600 Bandit	95 - 99	627 HS*		556 LS
GSF	600 Bandit / S Bandit				
	Left/Rear	00 - 04	705 HS		556 LS
GSF	600 Bandit / S Bandit				
	Right	00 - 04	704 HS		
GSR	600	06 - 10	631 HS*		833 LS
GSX	600 FW Left	98 - 04	705 HS		556 LS
GSX	600 FW Right	98 - 04	704 HS		
GSX	600 Katana	88 - 89	620 HF*		556 HF
GSX	600 Katana	90 - 97	620 HS*		556 LS
GSX-R	600	04 - 05	806 HS*		765 LS
GSX-R	600	06 - 10	806 HS*		833 LS
GSX-R	600	11 - 18	841 HS*		834 LS
GSX-R	600	92 - 93	624 HS*		556 LS
GSX-R	600	97 - 03	631 HS*		556 LS
RF	600 R	93 - 96	627 HS*		556 LS
SP	600 F	85 - 87	582 HF		2014
AN	650 A Burgman Executive	04 - 12	183 MS*		182 MS
AN	650 Burgman	02 - 15	183 MS*		182 MS
AN	650 Z Burgman Executive	13 - 18	183 MS*		182 MS
DL	650 V-Strom Left/Rear	04 - 13	705 HS		657 LS
DL	650 V-Strom Right	04 - 13	704 HS		
DL	650 V-Strom Left/Rear	17 - 18	705 HS		657 LS
DL	650 V-Strom Right	17 - 18	704 HS		
DL	650 V-Strom XT Left/Rear	15 - 18	705 HS		657 LS
DL	650 V-Strom XT Right	15 - 18	704 HS		
DR	650	90 - 95	626 HS		635 LS
DR	650 R	92	626 HS		635 LS
DR	650 SE T-W	96 - 99	694 HF		648 HF
GR	650	83 - 84	534 HF*		512 HF
GR	650 X	83 - 84	534 HF		2018
GS	650	81 - 83	534 HF*		512 HF
GS	650 G	83 - 87	534 HF*		512 HF
GS	650 Turbo, XN	83 - 85	534 HF*		512 HF

\* = 2 sets required / 2 jeux pour l'Avant.

Full compound selection, see under "Brake pad 1:1 Drawings" / Sélection complète de composés, voir "1:1 Schémas Plaquettes de frein".  
For ABE type approvals, see page 1 / Pour les homologations de type ABE, voir page 2.

**RECOMMENDED**1xx = Scooter Pads  
5xx = Street, Off Road & Racing Pads  
2xxx = Brake Shoes

SUZUKI					
GSF	650	Bandit	07 - 11	631 HS*	657 LS
GSF	650	Bandit / S Bandit Left/Rear	05	705 HS	765 LS
GSF	650	Bandit / S Bandit Left/Rear ABS	06	705 HS	657 LS
GSF	650	Bandit / S Bandit Right	05	704 HS	
GSF	650	Bandit / S Bandit Right ABS	06	704 HS	
GSF	650	Bandit ABS	07 - 12	631 HS*	657 LS
GSF	650	S Bandit	07 - 11	631 HS*	657 LS
GSF	650	S Bandit ABS	07 - 13	631 HS*	657 LS
GSX	650	F	08 - 18	631 HS*	657 HF
LS	650	P	86 - 88	581 HF	2018
LS	650	P Savage	95 - 04	581 HF	2018
S40	650	Boulevard	05 - 18	581 HF	2018
SFV	650	Gladius Left/Rear	09 - 16	705 HS	881 LS
SFV	650	Gladius Right	09 - 16	704 HS	
SV	650	,S ABS	07 - 10	705 HS	657 LS
SV	650	,S ABS	15 - 18	705 HS	657 LS
SV	650	,S Left/Rear	99 - 02	705 HS	556 LS
SV	650	,S Right	99 - 02	704 HS	
SV	650	,S Left/Rear	03 - 12	705 HS	657 LS
SV	650	,S Right	03 - 12	704 HS	
SV	650	Left/Rear	16 - 18	705 HS	881 LS
SV	650	Right	16 - 18	704 HS	
SV	650	X Left/Rear	18 -	705 HS	881 LS
SV	650	X Right	18 -	704 HS	
GS	700		85	533 HF*	512 HF
GV	700	GLG Madura	86	533 HF*	2052
LT-A	700	King Quad Left	05 - 11	835 SI	
LT-A	700	King Quad Right	05 - 11	836 SI	
LT-V	700	Quadrunner Twin Peaks Left	04 - 06	801 SI	
LT-V	700	Quadrunner Twin Peaks Right	04 - 06	798 SI	
VS	700	GLFG	86 - 87	577 HF	2052
GS	750		76 - 77	511 HF	512 HF
GS	750		78 - 79	515 HF*	512 HF
GS	750	D	77 - 79	511 HF*	512 HF
GS	750	E	77 - 79	511 HF*	512 HF
GS	750	Katana	85 - 86	556 HF*	556 HF
GS	750	RF	85	577 HF*	556 HF
GS	750	SD	83	534 HF*	512 HF
GSR	750	Left/Rear	11 - 16	705 HS	657 LS
GSR	750	Right	11 - 14	704 HS	
GSX	750	FW Left/Rear	98 - 02	705 HS	556 LS
GSX	750	FW Right	98 - 02	704 HS	
GSX	750	Katana	89 - 96	620 HS*	556 LS
GSX	750	Left/Rear	98 - 08	705 HS	556 LS
GSX	750	Right	98 - 08	704 HS	
GSX-R	750		04 - 05	806 HS*	765 LS
GSX-R	750		06 - 10	806 HS*	833 LS
GSX-R	750		11 - 18	841 HS*	834 LS
GSX-R	750		85 - 87	577 HF*	556 HF
GSX-R	750		88 - 93	624 HS*	556 LS
GSX-R	750		94 - 99	686 HS*	556 LS
GSX-R	750	Y	00 - 03	631 HS*	556 LS
GSX-S	750		17 - 18	782 HS*	657 LS
GSX-S	750	Left/Rear	15 - 16	705 HS	657 LS
GSX-S	750	Right	15 - 16	704 HS	
GSX-S	750	Z Left/Rear	15 - 16	705 HS	657 LS
GSX-S	750	Z Right	15 - 16	704 HS	
GT	750		73 - 77	503 HF*	2098
LT-A	750	King Quad Left	08 - 14	835 SI	
LT-A	750	King Quad Right	08 - 14	836 SI	
VS	750	Intruder	86 - 91	577 HF*	2052
C50	800	Boulevard	05 - 18	704 HS	2052

**RECOMMENDED**1xx = Scooter Pads  
5xx = Street, Off Road & Racing Pads  
2xxx = Brake Shoes

SUZUKI					
M50	800	Boulevard	05 - 18	704 HS	2052
S50	800	Boulevard	05 - 18	577 HS	2052
VL	800	Intruder LC Volusia	01 - 04	704 HS	2052
VS	800	Intruder	91 - 99	577 HS	2052
VX	800	L-P	90 - 93	597 HS	620 LS
VZ	800	Marauder	97 - 04	704 HS	2052
GS	850		79 - 81	511 HF*	512 HF
GS	850		80 - 82	533 HF	512 HF
GS	850		80 - 82	533 HF*	512 HF
GS	850	G	83 - 86	533 HF*	512 HF
RF	900	RR,RS,RS2,T,V	94 - 97	714 HS*	701 LS
DL	1000	V-Strom	14 - 18	806 SP*	833 LS
DL	1000	V-Strom Left/Rear	02 - 13	705 HS	657 LS
DL	1000	V-Strom Right	02 - 13	704 HS	
DL	1000	V-Strom XT	17 - 18	806 SP*	833 LS
G	1000	SZ	82	534 HF*	512 HF
GS	1000		78 - 80	515 HF*	512 HF
GS	1000		80 - 81	533 HF*	512 HF
GS	1000	ET	81	534 HF*	512 HF
GS	1000	EX	81	534 HF*	512 HF
GSX-R	1000		03	788 HS*	765 LS
GSX-R	1000		04 - 06	806 HS*	765 LS
GSX-R	1000		07 - 08	806 HS*	833 LS
GSX-R	1000		09 - 11	806 SP*	834 LS
GSX-R	1000		12 - 18	841 SP*	834 LS
GSX-R	1000		01 - 02	686 HS*	765 LS
GSX-R	1000	R	17 - 18	841 SP*	834 LS
GSX-S	1000		15 - 18	841 HS*	657 LS
GSX-S	1000	F	15 - 18	841 HS*	657 LS
SV	1000	, S	03 - 07	631 HS*	657 LS
TL	1000	RW	98 - 02	686 HS*	556 LS
TL	1000	S V-Twin	97 - 01	631 HS*	556 LS
GS	1100		81	534 HF*	512 HF
GS	1100		82 - 83	533 HF	512 HF
GS	1100	ED, ESD, GD	83	534 HF*	512 HF
GS	1100	G	86 - 88	534 HF*	512 HF
GS	1100	GKD, SD, GLD	83	534 HF*	512 HF
GS	1100	L	79	534 HF*	512 HF
GSX	1100		88 - 89	620 HF*	577 HF
GSX	1100		90 - 93	620 HS*	577 LS
GSX	1100		91 - 93	597 HS*	620 LS
GSX	1100	F	93 - 96	620 HS*	556 LS
GSX	1100	G	94 - 95	597 HS*	615 LS
GSX	1100	G Left/Rear	96 - 98	705 HS	556 LS
GSX	1100	G Right	96 - 98	704 HS	
GSX	1100	Katana	93	624 HS*	556 LS
GSX-R	1100		86 - 88	577 HF*	556 HF
GSX-R	1100		89 - 92	624 HS*	556 LS
GSX-R	1100		93 - 97	686 HS*	556 LS
GT	1100		80	534 HF*	512 HF
GS	1150	EG	86 - 87	577 HF*	577 HF
GS	1150	ES	84 - 85	577 HF*	577 HF
GSF	1200	Bandit	95 - 96	624 HS*	556 LS
GSF	1200	Bandit	97 - 00	714 HS*	556 LS
GSF	1200	Bandit	01 - 05	686 HS*	556 LS
GSF	1200	Bandit	06	631 HS*	657 LS
GSF	1200	S Bandit	01 - 05	686 HS*	556 LS
GSF	1200	S Bandit	06	631 HS*	657 LS
GV	1200	GLG Madura	86	533 HF*	512 HF
GSF	1250	A Bandit	07 - 18	631 HS*	657 LS
GSF	1250	Bandit	06 - 18	631 HS*	657 LS
GSF	1250	F Bandit	12 - 18	631 HS*	657 LS
GSF	1250	S Bandit	06 - 18	631 HS*	657 LS
GSF	1250	SA Bandit	07 - 18	631 HS*	657 LS
GSX	1250	FA Bandit	16 - 18	631 HS*	657 LS
GSX	1250	FA Traveller	15 - 16	631 HS*	657 LS
	1300	B-King	07	838 HS*	657 LS
GSX-R	1300	Hayabusa	99 - 07	686 HS*	556 LS

\* = 2 sets required / 2 jeux pour l'Avant.





**RECOMMENDED**

1xx = Scooter Pads  
5xx = Street, Off Road & Racing Pads  
2xxx = Brake Shoes



SUZUKI					
GSX-R	1300	Hayabusa	08 - 12	806 HS*	833 LS
GSX-R	1300	Hayabusa	13 - 18	841 HS*	833 LS
	1340	B-King	08 - 14	782 HS*	833 LS
GL	1400	Cavalcade	87 - 88	620 HF*	577 HF
GSX	1400		02 - 07	686 HS*	765 LS
GV	1400	Cavalcade	85 - 86	534 HF*	512 HF
GV	1400	Cavalcade LXE	87 - 90	577 HS*	577 LS
S83	1400	Boulevard	05 - 10	577 HS	577 LS
VS	1400	GL Intruder	87 - 04	577 HS	577 LS
C	1500	T Intruder	13 - 18	627 HS	886 LS
C90	1500	Boulevard B.O.S.S.	13 - 18	627 HS	886 LS
C90	1500	Boulevard Left/Rear	05 - 18	705 HS	789 LS
C90	1500	Boulevard Right	05 - 18	704 HS	
M90	1500	Left/Rear	09 - 18	705 HS*	886 LS
M90	1500	Right	09 - 18	704 HS*	
VL	1500	Intruder LC	98 - 01	577 HS	577 LS
VL	1500	Intruder LC Left/Rear	02	705 HS	789 LS
VL	1500	Intruder LC Right	02	704 HS	
M95	1600	Boulevard	05 - 07	788 HS*	886 LS
VZ	1600	Marauder	04	686 HS*	886 LS
C109R	1800		08 - 12	828 HS*	920 LS
M	1800	R Intruder	06 - 16	806 HS*	920 LS
M109R	1800		06 - 18	806 HS*	920 LS
M109R	1800	BOSS	14	806 HS*	920 LS
M109R2	1800		08 - 16	806 HS*	920 LS
SWM					
RS	300	R	15 - 18	671 SI	791 SI
	440	Gran Milano	15 - 17	627 HS	
	440	Gran Milano	18 -	762 HS	
	440	Gran Turismo	15 - 18	627 HS	
	440	Silver Vase	15 - 18	627 HS	
	440	Six Days	18 -	627 HS	
SM	450	R	15 - 17	762 HS	791 HF
RS	500	R	15 - 18	671 SI	791 SI
SM	500	R	18 -	762 HS	791 HF
	600	Superdual GT Pack	18 -	674 HS	675 LS
	600	Superdual T	18 -	674 HS	675 LS
	600	Superdual X	18 -	674 HS	675 LS
	650	Superdual	15 - 18	762 HS	675 LS
SYM					
	50	Allo	11 - 15	140 HF	
	50	Bullet	93	110 HF	
	50	Cinderella	01 - 00	110 HF	
	50	Crox	14 - 15	140 CT	
	50	Feel-big	98	618 HF	
	50	Fiddle	09 - 14	140 HF	2012
	50	Fiddle III	16 - 18	140 CT	202 CT
	50	Jet 4 Naked	11 - 13	140 HF	
	50	Jet 4 R	11 - 13	140 HF	
	50	Jet BasiX	07 - 09	140 HF	
	50	Jet Euro X	05 - 12	140 HF	
	50	Jet Sport X	06 - 14	140 HF	
	50	Jet Sport X SR	06 - 14	140 HF	129 HF
	50	Jet, Alpha	95 - 97	140 HF	2012
	50	Jungle	96 - 02	140 HF	2012
	50	Mask	00 - 05	140 HF	2012
	50	Mask LC	00 - 05	140 HF	2012
	50	Mio	05 - 16	110 HF	2057
	50	Orbit II	12 - 13	140 HF	
	50	Pure	98	618 HF	
	50	Red Devil	97 - 09	140 HF	2012
	50	Super Fancy	95 - 97	140 HF	2012
	50	Super Fancy	98 - 06	115 HF	
	50	Symphony	09 - 15	140 HF	
	50	Symphony SR	11 - 15	140 HF	
	50	Symphony ST	15	140 CT	



**RECOMMENDED**

1xx = Scooter Pads  
5xx = Street, Off Road & Racing Pads  
2xxx = Brake Shoes



SYM					
	50	Symply	08 - 14	140 HF	
	50	X'Pro	13 - 17	140 HF	
DD	50		02 - 12	110 HF	2057
RS	50		05 - 09	178 HF	2012
RS21	50		02 - 09	178 HF	
	100	Cinderella	01	110 HF	
	100	Jet	00	140 HF	
	100	Jet Euro X	05	140 HF	
	100	Jet Sport X	05	140 HF	
	100	Mio	05 - 16	110 HF	
	100	Party	97 - 00	140 HF	
	100	Super Fancy	95 - 00	140 HF	2012
	110	Bullet	93	542 HF	
	110	Star	03	140 HF	
	125	Aero Wolf	02	542 HF	
	125	Allo	11 - 15	140 CT	
	125	Attila	95 - 02	708 HF	2012
	125	Citycom	09 - 14	140 CT	
	125	Crox	14 - 15	140 CT	
	125	Euro MX	03 - 04	178 CT	
	125	Fiddle	09 - 16	140 CT	
	125	Fiddle III	16 - 18	140 CT	202 CT
	125	GTS	07 - 11	146 CT	
	125	Husky	96 - 98	135 CT	2188
	125	Husky	99 - 05	150 CT	
	125	Jet 14	17 - 18	140 CT	202 CT
	125	Jet 4	11 - 13	140 HF	
	125	Joymax Sport	16	146 CT	201 CT
	125	Joyride	01 - 06	178 CT	154 CT
	125	Joyride	07 - 09	178 CT	201 CT
	125	Joyride Evo	10 - 12	178 CT	201 CT
	125	Joyride S	16 - 17	178 CT	201 CT
	125	Megalo	02 - 05	140 CT	
	125	New Duke	02 - 07	140 CT	
	125	Super Duke	95 - 01	140 CT	2188
	125	Symphony	09 - 15	140 CT	
	125	Symphony EX	17	140 CT	
	125	Symphony S	11 - 17	140 CT	202 CT
	125	Symphony SR	11 - 17	140 CT	202 CT
	125	Symphony ST	15 - 18	140 CT	202 CT
	125	Symply	08 - 14	140 CT	
	125	Voyager	05	171 CT	
	125	Wolf Classic	05	551 HF	
	125	Wolf Legend	02 - 05	103 CT	
	125	X'Pro	14 - 16	140 CT	
HD	125		04 - 10	154 CT	
HD	125	Evo DT	10	140 CT	201 CT
HD2	125	Evo	14	140 CT	201 CT
RS	125		05 - 06	178 CT	119 CT
RS21	125	, R	02	178 CT	
SB	125	Wolf Ni	11 - 13	847 HF	810 HF
VS	125		07 - 13	792 HF	
VS	125		09 - 13	178 CT	
	150	Attila	00 - 03	140 CT	
	150	Crox	14 - 16	140 CT	
	150	Euro MX	03 - 06	178 CT	
	150	Husky	99 - 02	150 CT	2188
	150	Jet 4	11 - 14	140 HF	
	150	Joyride	01 - 06	178 CT	154 CT
	150	Super Duke	96 - 01	140 CT	2012
	150	Symphony S	11 - 15	140 CT	202 CT
	150	Symphony SR	11 - 15	140 CT	202 CT
H01	150		95 - 00	708 HF	
RS	150		05 - 06	178 CT	119 CT
VS	150		07 - 15	792 HF	
MF	180		03	551 HF	
	200	Fiddle II	11 - 13	140 CT	
	200	Fiddle III	16 - 18	140 CT	202 CT

\* = 2 sets required / 2 jeux pour l'Avant.

Full compound selection, see under "Brake pad 1:1 Drawings" / Sélection complète de composés, voir "1:1 Schémas Plaquettes de frein".  
For ABE type approvals, see page 1 / Pour les homologations de type ABE, voir page 2.

**RECOMMENDED**1xx = Scooter Pads  
5xx = Street, Off Road & Racing Pads  
2xxx = Brake Shoes

SYM				
	200	Joyride	01 - 08	178 CT
	200	Joyride Evo	09 - 15	140 CT
	200	Joyride S	16 - 17	178 CT
	200	Quadlander	12 - 13	810 SI*
	200	Trackrunner	05 - 08	810 SI*
HD	200		04 - 06	154 CT
HD	200	Evo	07 - 13	140 CT
HD2	200	Evo	14	140 CT
	250	GTS	07 - 11	146 MS
	250	Joymax	07 - 10	171 MS
	250	Joymax Sport	16 - 17	146 MS
	250	Quadlander	06 - 07	810 SI*
	250	Voyager	05	171 MS
RV	250	Efi	10	146 MS
SN	250	Ni Wolf	14 - 15	893 HF
SN	250	T2 Wolf	12 - 15	893 HF
	300	City Max	06 - 07	810 SI*
	300	Citycom	09 - 15	140 CT
	300	Citycom S	15 - 17	140 CT
	300	Cruisym	17	215 MS
	300	Joymax Evo	10 - 12	146 MS
	300	Joymax Sport	16 - 17	146 MS
	300	Joyride Evo i	10	146 MS
	300	Quadlander	06 - 13	810 SI*
	300	Wolf Cafe Racer	15	893 HF
	300	Wolf Classic	15	893 HF
GTS	300		09 - 13	146 MS
GTS	300	Evo i	11 - 15	146 MS
SB	300	Cafe Racer	16 - 17	893 HF
	400	i Maxsym	11	214 MS*
	400	i Maxsym	12 - 17	215 MS*
	500	GT	07 - 04	146 MS
	600	i Maxsym	14 - 18	215 MS*
	600	i Maxsym Sport	18 -	215 MS*
	600	Quad Raider	08 - 15	810 SI*
<b>TGB</b>				
	50	101R	05 - 09	101 HF
	50	101S	99 - 02	101 HF
	50	202T	99 - 02	101 HF
	50	203	05 - 08	163 HF
	50	303R	99 - 14	101 HF
	50	309 Racing	05	101 HF
	50	507	05	101 HF
	50	Akros	99 - 04	101 HF
	50	Akros tec 5	99 - 04	163 HF
	50	Apollo	99 - 03	163 HF
	50	Buffalo	03	688 HF
	50	Bull&t RS/RR	11 - 17	203 HF
	50	Bullet	09	101 HF
	50	Bullet	10 - 12	203 HF
	50	Bunny	97 - 00	101 HF
	50	Corona	03 - 05	132 HF
	50	Double X	05	101 HF
	50	Ergon	96 - 00	101 HF
	50	Fire, Sky	03 - 05	163 HF
	50	Hawk	09 - 14	101 HF
	50	Hiw's	99	101 HF
	50	Hook	10 - 12	101 HF
	50	J409	00 - 03	101 HF
	50	Tapo RS	11 - 12	101 HF
	50	Trigger	99 - 03	101 HF
GT	50	Veloce	09 - 12	141 HF
R	50	X	06 - 14	132 HF
	90	101S	99 - 02	101 HF
	90	202T	99 - 02	101 HF
	90	Akros	99	101 HF
	90	Apollo	99 - 02	163 HF

**RECOMMENDED**1xx = Scooter Pads  
5xx = Street, Off Road & Racing Pads  
2xxx = Brake Shoes

TGB				
	90	Ergon	99 - 02	101 HF
	90	Hiw's	99	101 HF
	90	Trigger	99 - 02	101 HF
	125	101S	99 - 03	101 CT
	125	202T	99	101 CT
	125	303R	99 - 08	101 CT
	125	309 RS	00	101 HF
	125	Bull&t RS/RR	11 - 14	203 HF
	125	Hook	10	101 HF
	125	X-Large	11	210 CT
	125	X-Motion	08 - 12	210 CT
	250	Dynasty	06	163 CT
	250	X-Motion	08 - 09	210 MS
	300	X-Motion	10 - 12	210 MS
<b>TM</b>				
	80	Cross	96 - 00	671 RSI
	80	Junior	96 - 00	544 RSI
MX	85		01 - 12	671 RSI
MX	85		13 - 18	777 RSI
SM	85		18 -	777 RSI
	125		96 - 00	671 RSI
	125		01 - 04	671 RSI
	125		05 - 17	671 RSI
	125	Enduro	01 - 04	671 SI
	125	Enduro	05 - 17	671 SI
SMR	125		05	566 RSI
	250		01 - 04	671 RSI
	250		05	671 RSI
	250	E	95 - 00	671 RSI
	250	Enduro	01 - 04	671 SI
	250	Enduro	05 - 15	671 SI
	250	F	01 - 04	671 RSI
	250	F	05 - 17	671 RSI
	250	F Enduro	00	671 SI
	250	F Enduro	01 - 04	671 SI
	250	F Enduro	05 - 17	671 SI
	300		98 - 00	671 RSI
	300		01 - 04	671 RSI
	300		05	671 RSI
	300	Enduro	01 - 04	671 SI
	300	Enduro	05	671 SI
	320		96 - 97	671 RSI
	400	F	00	671 RSI
	400	F	01	671 RSI
	400	F Enduro	01	671 SI
SMF	400	F	02	566 RSI
SMR	400	F	03	566 RSI
	450	F	02 - 04	671 RSI
	450	F	05 - 17	671 RSI
	450	F Enduro	02 - 04	671 SI
	450	F Enduro	05 - 17	671 SI
FT	450	Fi	17	671 RSI
SMR	450	F	04	566 RSI
SMX	450	F	03	566 RSI
SMX	450	F	04	762 RS
	530	F	01 - 04	671 RSI
	530	F	05	671 RSI
	530	F Enduro	01 - 04	671 SI
	530	F Enduro	05	671 SI
SMR	530	F	03	566 RSI
SMX	600	F	03	566 RSI
SMX	660	F	04	762 RS
<b>TOMOS</b>				
	50	Hip Hop	06 - 08	105 HF
	50	Racing	06 - 08	105 HF
	50	Revival	02 - 04	123 HF

\* = 2 sets required / 2 jeux pour l'Avant.



**RECOMMENDED**

1xx = Scooter Pads  
5xx = Street, Off Road & Racing Pads  
2xxx = Brake Shoes



TOMOS			
	50 Street Soul	06 - 08	105 HF
	50 Streetmate	03 - 05	123 HF
	50 Youngst'r	06 - 08	105 HF
BT	50 S	89	595 HF
MC	50 Senior Pro	04 - 06	667 HF 667 HF
N	50 AT, BT	91 - 95	595 HF
SE	50	05 - 06	148 HF 105 HF
CTX	80	89	595 HF
MC	125 T	06 - 08	817 HF 559 HF
SE	125	05 - 08	817 HF 559 HF
SM	125 F	06 - 08	821 HS 559 HF

TRIUMPH			
	600 Daytona	03 - 04	624 HS* 614 LS
	600 Speed Four	03 - 06	624 HS* 614 LS
TT	600	00 - 03	624 HS* 614 LS
	650 Daytona	05 - 06	624 HS* 614 LS
	660 Street Triple S A2	17 - 18	627 HS* 675 LS
	675 Daytona	06 - 08	782 HS* 614 LS
	675 Daytona R Triple	11 - 12	901 HS* 614 LS
	675 Daytona R Triple	13 - 18	901 HS* 675 LS
	675 Daytona Triple	09 - 12	864 HS* 614 LS
	675 Daytona Triple	13 - 18	864 HS* 675 LS
	675 Street Triple	08 - 12	627 HS* 614 LS
	675 Street Triple	13 - 17	627 HS* 675 LS
	675 Street Triple R	09 - 12	782 HS* 614 LS
	675 Street Triple R	13 - 17	782 HS* 675 LS
	675 Street Triple RX	15 - 16	782 HS* 675 LS
	750 Bonneville	84	554 HF
	750 Bonneville U.K.	87	506 HF* 506 HF
	750 Daytona	91 - 92	624 HS* 633 LS
	750 Trident Left/Rear	91 - 98	611 HS 611 LS
	750 Trident Right	91 - 98	638 HS
	750 Trident T160V	75 - 77	523 HF 523 HF
T140	750 D,E,F,V Bonneville	76 - 81	523 HF 523 HF
T140	750 ES Bonneville	81 - 83	523 HF* 523 HF
TR65	750 Thunderbird	81 - 83	523 HF
TR7T	750 Tiger Trail	81 - 83	523 HF
TR7V	750 Tiger	73 - 81	523 HF 523 HF
TSS	750	83	523 HF* 523 HF
TSS	750 Electro Eight Valve	84	523 HF
TSX	750	83	523 HF 523 HF
	765 Street Triple R	17 - 18	900 HS* 675 LS
	765 Street Triple R Low	17 - 18	900 HS* 675 LS
	765 Street Triple RS	17 - 18	901 HS* 675 LS
	765 Street Triple S	17 - 18	627 HS* 675 LS
	800 America	03 - 06	627 HS 611 LS
	800 Bonneville	01 - 04	627 HS 611 LS
	800 Bonneville America	02 - 06	627 HS 611 LS
	800 Bonneville T100 Centennial Edition	02 - 04	627 HS 611 LS
	800 Bonneville T100 Paul Smith	06 - 08	627 HS 611 LS
	800 Speedmaster	03 - 04	627 HS* 611 LS
	800 Tiger	11 - 14	627 HS* 614 LS
	800 Tiger XC	11 - 17	627 HS* 614 LS
	800 Tiger XC ABS	12 - 14	627 HS* 614 LS
	800 Tiger XCA	15 - 17	627 HS* 614 LS
	800 Tiger XCA	18 -	671 HS* 614 LS
	800 Tiger XCR	15 - 17	627 HS* 614 LS
	800 Tiger XCX	18 -	671 HS* 614 LS
	800 Tiger XR	15 - 17	627 HS* 614 LS
	800 Tiger XR	18 -	627 HS* 614 LS
	800 Tiger XRT	15 - 17	627 HS* 614 LS
	800 Tiger XRT	18 -	671 HS* 614 LS
	800 Tiger XRX	15 - 17	627 HS* 614 LS
	800 Tiger XRX	18 -	671 HS* 614 LS
	800 Tiger XRX Low	18 -	671 HS* 614 LS



**RECOMMENDED**

1xx = Scooter Pads  
5xx = Street, Off Road & Racing Pads  
2xxx = Brake Shoes



TRIUMPH			
	900 Adventurer	96 - 02	627 HS 630 LS
	900 America	07 - 16	627 HS 611 LS
	900 Bonneville	05 - 08	627 HS 638 LS
	900 Bonneville	09 - 11	627 HS 611 LS
	900 Bonneville Newchurch	15	627 HS 611 LS
	900 Bonneville SE	09 - 13	627 HS 611 LS
	900 Bonneville Spirit	15	627 HS 611 LS
	900 Bonneville Street Cup	17 - 18	627 HS 611 LS
	900 Bonneville T100	05 - 18	627 HS 611 LS
	900 Bonneville T100 Black	16 - 18	627 HS 611 LS
	900 Bonneville T214	15	627 HS 611 LS
	900 Daytona	91 - 94	624 HS* 633 LS
	900 Daytona	94 - 98	624 HS* 638 LS
	900 Daytona Super III	94 - 98	683 HS* 633 LS
	900 Daytona, Sprint Left/Rear	93	611 HS 611 LS
	900 Daytona, Sprint Right	93	638 HS
	900 Legend TT	99 - 01	627 HS 630 LS
	900 Scrambler	06 - 16	627 HS 611 LS
	900 Speed Triple	94 - 96	624 HS* 638 LS
	900 Speedmaster	05 - 15	627 HS* 611 LS
	900 Sprint	94 - 98	624 HS* 638 LS
	900 Street Scrambler	17 - 18	627 HS 611 LS
	900 Street Twin	16 - 18	627 HS 611 LS
	900 Thruxton	04 - 05	627 HS 611 LS
	900 Thruxton Ace	15	627 HS 611 LS
	900 Thunderbird	96 - 05	627 HS 630 LS
	900 Thunderbird Sport	03 - 04	627 HS* 630 LS
	900 Tiger	99 - 00	627 HS* 630 LS
	900 Tiger Left/Rear	93 - 98	611 HS 611 LS
	900 Tiger Right	93 - 98	638 HS
	900 Trident Left/Rear	91 - 98	611 HS 611 LS
	900 Trident Right	91 - 98	638 HS
	900 Trophy	96 - 03	624 HS* 633 LS
	900 Trophy Left/Rear	91 - 95	611 HS 611 LS
	900 Trophy Right	91 - 95	638 HS
T509	900 Speed Triple	97 - 01	624 HS* 611 LS
T595	950 Daytona	96 - 98	624 HS* 611 LS
	955 Daytona Centennial	02 - 04	624 HS* 611 LS
	955 Daytona from VIN 132513	99 - 01	624 HS* 614 LS
	955 Daytona to VIN 132512	99 - 06	624 HS* 611 LS
	955 Speed Triple	99 - 06	624 HS* 611 LS
	955 Sprint RS	00 - 05	624 HS* 611 LS
	955 Sprint ST	99 - 04	624 HS* 611 LS
	955 Tiger	01 - 04	627 HS* 627 HF
	955 Tiger	04 - 06	627 HS* 638 LS
	1000 Daytona	92	624 HS* 633 LS
	1000 Trophy Left/Rear	91 - 95	611 HS 611 LS
	1000 Trophy Right	91 - 95	638 HS
	1050 Speed 94	15 - 16	762 HS* 611 LS
	1050 Speed 94R	15 - 16	901 HS* 611 LS
	1050 Speed Triple	16 - 17	901 HS* 611 LS
	1050 Speed Triple	05 - 07	782 HS* 611 LS
	1050 Speed Triple	08 - 15	762 HS* 611 LS
	1050 Speed Triple R	12 - 18	901 HS* 611 LS
	1050 Speed Triple S	16 - 18	901 HS* 611 LS
	1050 Sprint GT ABS	10 - 15	624 HS* 611 LS
	1050 Sprint GT SE ABS	10 - 15	624 HS* 611 LS
	1050 Sprint ST	05 - 11	624 HS* 611 LS
	1050 Tiger	07 - 13	782 HS* 638 LS
	1050 Tiger SE	09 - 13	782 HS* 638 LS
	1050 Tiger Sport	15 - 18	782 HS* 611 LS
	1200 Bonneville Bobber	17	627 HS 614 LS
	1200 Bonneville Bobber Black	18 -	671 HS* 614 LS
	1200 Bonneville T120	16 - 18	627 HS 611 LS

Applications  
Motorcycles, Off Road, ATV/UTV, Scooters

\* = 2 sets required / 2 jeux pour l'Avant.

Full compound selection, see under "Brake pad 1:1 Drawings" / Sélection complète de composés, voir "1:1 Schémas Plaquettes de frein".  
For ABE type approvals, see page 1 / Pour les homologations de type ABE, voir page 2.



**RECOMMENDED**1xx = Scooter Pads  
5xx = Street, Off Road & Racing Pads  
2xxx = Brake Shoes**TRIUMPH**

1200	Bonneville T120 Black	16 - 18	627 HS	611 LS
1200	Daytona	91 - 97	624 HS*	633 LS
1200	Speedmaster	18 -	671 HS*	614 LS
1200	Thruxton	16 - 18	627 HS*	611 LS
1200	Thruxton R	16 - 18	901 HS*	611 LS
1200	Tiger Explorer	12 - 15	624 SP*	611 LS
1200	Tiger Explorer	16 - 17	900 SP*	611 LS
1200	Tiger XCA	18 -	900 SP*	611 LS
1200	Tiger XCX	18 -	900 SP*	611 LS
1200	Tiger XR	18 -	900 SP*	611 LS
1200	Tiger XRT	18 -	900 SP*	611 LS
1200	Tiger XRX	18 -	900 SP*	611 LS
1200	Tiger XRX Low	18 -	900 SP*	611 LS
1200	Trophy	96 - 03	624 HS*	633 LS
1200	Trophy Left/Rear	91 - 95	611 HS	611 LS
1200	Trophy Right	91 - 95	638 HS	
1200	Trophy SE	13 - 18	740 HS*	611 LS
1600	Thunderbird	09 - 18	624 HS*	674 LS
1700	Thunderbird			
	Commander	14 - 18	624 HS*	674 LS
1700	Thunderbird LT	14 - 18	624 HS*	674 LS
1700	Thunderbird			
	Nightstorm	14 - 18	624 HS*	674 LS
1700	Thunderbird Storm	11 - 18	624 HS*	674 LS
2300	Rocket III	04 - 13	624 HS*	674 LS
2300	Rocket III Classic	07 - 13	624 HS*	674 LS
2300	Rocket III Roadster	10 - 18	624 HS*	674 LS
2300	Rocket III Touring	13 - 14	624 HS*	674 LS
2300	Rocket X	15	624 HS*	674 LS

**TRS**

250	ONE	16 - 18	802 RSI	803 RSI
280	ONE	16 - 18	802 RSI	803 RSI
300	ONE	16 - 18	802 RSI	803 RSI

**VERTEMATI**

C	500 Cross	02 - 04	671 RSI	675 RSI
E	501 Enduro	02 - 04	671 SI	675 SI
S	501 Supermotard	02 - 04	671 HF	675 HF

**VERTIGO**

300	Combat Camo Works	15 - 18	939 RSI	803 RSI
300	Combat Ice Hell	15 - 18	939 RSI	803 RSI
300	Combat RR	15 - 18	939 RSI	803 RSI

**VICTORY**

	Empulse TT	16 - 17	706 H.HS*	730 H.LS
1200	Octane	17	674 H.HS	675 H.LS
1500	Kingpin	04 - 05	706 H.HS	674 H.LS
1500	Touring Cruiser	03 - 06	706 H.HS*	674 H.LS
1500	V92C Cruiser	98 - 02	706 H.HS	674 H.LS
1500	V92C Deluxe	01 - 02	706 H.HS	674 H.LS
1500	V92SC Sport Cruiser	00 - 02	706 H.HS*	674 H.LS
1500	Vegas	03 - 05	706 H.HS	674 H.LS
1500	Vegas 8-Ball	05	706 H.HS	674 H.LS
1634	Hammer	05 - 07	706 H.HS	674 H.LS
1634	Hammer	08	782 H.HS*	630 H.LS
1634	Hammer S	06 - 08	706 H.HS	674 H.LS
1634	Kingpin	06 - 07	706 H.HS	674 H.LS
1634	Kingpin all models	08 - 12	782 H.HS	630 H.LS
1634	Kingpin Tour	06 - 07	706 H.HS	674 H.LS
1634	Vegas	06 - 07	706 H.HS	674 H.LS
1634	Vegas	08 - 17	782 H.HS	630 H.LS
1634	Vegas 8-Ball	06 - 07	706 H.HS	674 H.LS
1634	Vegas 8-Ball	08 - 17	782 H.HS	630 H.LS
1634	Vegas Jackpot	06 - 07	706 H.HS	674 H.LS
1634	Vegas Jackpot	08	782 H.HS	630 H.LS
1731	Boardwalk	13 - 15	782 H.HS	630 H.LS

**RECOMMENDED**1xx = Scooter Pads  
5xx = Street, Off Road & Racing Pads  
2xxx = Brake Shoes**VICTORY**

1731	Cross Country	10 - 17	782 H.HS*	630 H.LS
1731	Cross Country 8-Ball	14 - 16	782 H.HS*	630 H.LS
1731	Cross Country Tour	12 - 17	782 H.HS*	630 H.LS
1731	Cross Roads	10 - 12	782 H.HS*	630 H.LS
1731	Cross Roads 8-Ball	14	782 H.HS*	630 H.LS
1731	Cross Roads Classic	14	782 H.HS*	630 H.LS
1731	Gunner	15 - 17	782 H.HS	630 H.LS
1731	Hammer	09 - 11	782 H.HS*	630 H.LS
1731	Hammer 8-Ball	10 - 16	782 H.HS*	630 H.LS
1731	Hammer S	09 - 17	782 H.HS*	630 H.LS
1731	Hard-Ball	12 - 13	782 H.HS*	630 H.LS
1731	High-Ball	12 - 17	782 H.HS	630 H.LS
1731	Jackpot	10 - 16	782 H.HS	630 H.LS
1731	Judge	13 - 17	782 H.HS	630 H.LS
1731	Kingpin	10 - 12	782 H.HS	630 H.LS
1731	Kingpin 8-Ball	10 - 11	782 H.HS	630 H.LS
1731	Magnum	15 - 17	782 H.HS*	630 H.LS
1731	Magnum X-1	15 - 17	782 H.HS*	630 H.LS
1731	Vegas	10 - 17	782 H.HS	630 H.LS
1731	Vegas 8-Ball	10 - 17	782 H.HS	630 H.LS
1731	Vegas Jackpot	09	782 H.HS	630 H.LS
1731	Vision all models	08 - 17	735 H.HS*	630 H.LS

**VOR**

	400 Cross	00 - 01	671 RSI	675 RSI
	400 Enduro	00 - 01	671 SI	675 SI
EN	400	02 - 03	671 SI	675 SI
MX	400	02	671 RSI	675 RSI
SM	400	02	566 RSI	675 RSI
EN	450	02 - 04	671 SI	675 SI
MX	450	02 - 04	671 RSI	675 RSI
SM	450	02 - 04	566 RSI	675 RSI
	500 492 Enduro	99	671 SI	675 SI
	500 492 Super Motard	00 - 01	566 HF	675 HF
	500 495 Cross	99	671 RSI	675 RSI
EN	530	02 - 04	671 SI	675 SI
MX	530	02 - 04	671 RSI	675 RSI
SM	530	02 - 04	566 RSI	675 RSI

**YAMAHA**

	50 AJP Caliper			
	incl. pin/spring	91 - 18	188 HF	
	50 Axis Pro Foot	92 - 99	111 HF	2012
BW	50	91 - 94	2050	2050
BW	50	03 - 05	619 HF	
BW	50 Bump	97 - 02	123 HF	2050
BW	50 Next Generation	96 - 07	123 HF	2050
BW	50 Sports Spec R	02 - 06	123 HF	
BW	50 Spy	95 - 03	123 HF	2050
CA	50 Riva Salient	83 - 86	2112	2021
CG	50 A, B Riva Jog	90 - 91	2112	2021
CR	50 Target	91 - 95	111 HF	2028
CR	50 Z	91 - 95	111 HF	2050
CV	50 A/R Jog	03 - 08	206 HF	
CV	50 Jog, Jog ZR	01 - 06	165 HF	
CW	50 TA Zuma	90	2050	2050
CY	50 F Jog	94	2021	2028
DT	50 R	96 - 97	107 HF	2050
JOG	50 CY	90 - 92	2021	2050
JOG	50 E	88 - 90	2112	2021
JOG	50 R	02 - 07	111 HF	2050
JOG-Z	50	90 - 91	114 HF	2021
LB	50 Chappy	80 - 83	2032	2032
LC	50 M, Bop, G,H Champ	80 - 81	2021	2021
PW	50	80 - 87	2112	2112
PW	50	90 - 95	2112	2112
PW	50 H1	96 - 18	2112	2112
QT	50 Yamahopper	79 - 87	2112	2112

\* = 2 sets required / 2 jeux pour l'Avant.



**RECOMMENDED**

1xx = Scooter Pads  
5xx = Street, Off Road & Racing Pads  
2xxx = Brake Shoes



YAMAHA				
RD	50 MX	81 - 87	547 HF	2032
SG	50 Sting	84 - 91	2021	2021
SH	50 E, F Razz	93 - 95	2112	2021
SH	50 Mint	93 - 96	2112	2021
SH	50 T,EMT,U,MU,W,MW, A,MA,B,D,MD	87 - 93	2112	2021
TDR	50	90 - 92	107 HF	107 HF
TRAFIC	50 M	83	2050	2050
TT-R	50	06 - 18	2010	2010
TZM	50 R	94 - 97	134 HF	107 HF
TZR	50	90 - 92	134 HF	107 HF
TZR	50	93 - 02	134 HF	137 HF
TZR	50	03 - 04	168 HF	105 HF
YE	50 Zest (Italy)	92 - 95	114 HF	2028
YFM	50 Raptor	04 - 11	2028	2034
YM	50 Breeze, Fizz	95	114 HF	2050
YN	50 Neo's, LC	97 - 16	123 HF	2050
YSR	50	87 - 91	575 HF	2028
YSR	50	92	575 HF	2032
YW	50 Zuma	02 - 11	111 HF	
YW	50 Zuma	12 - 17	206 HF	
YZ	50	80 - 83	2182	2182
RD	60	73 - 75	2032	2032
YF	60 S Moto 4	86		2050
YT	60 Tri Zinger	84 - 85		2050
YZ	60	85	2182	2182
BW	80	86 - 90	2182	2182
YE	80 Zest (Italy)	93 - 94	114 HF	
YFM	80	87 - 88	2050	2034
YFM	80	92 - 94	2028	2034
YFM	80 Badger	95 - 07	2028	2034
YFM	80 Grizzly	05 - 08	2028	2034
YFM	80 N, S Moto 4	85 - 86		2034
YFM	80 Raptor	02 - 08	2028	2034
YZ	80	74 - 79	2182	2032
YZ	80	80 - 85	2182	2182
YZ	80	86 - 92	589 SI	2182
YZ	80	93 - 01	589 RSI	592 RSI
YZ	85 , LW	02 - 18	589 RSI	592 RSI
JOG	90	90 - 91	111 HF	2021
TT-R	90	00 - 10	2182	2028
YFM	90 RY Raptor	09 - 15	2028	586 SI
	100 Aerox	00 - 06	123 HF	2034
DT	100	76 - 80	2032	2034
RS	100	75 - 80	2032	2032
RT	100 A-H	90 - 96	2028	2028
YFM	100 Champ	87 - 88	2050	2034
YFM	100 Champ	89 - 91	2028	2034
YZ	100	78 - 81	2032	2034
YZ	100	82 - 83	2028	2034
	110 Mio	05 - 07	165 HF	
	110 Mio Sporty	05 - 07	165 HF	
	110 Nouvo	06 - 07	165 HF	
TT-R	110	08 - 18	2182	2028
	115 D'elight	14 - 18	858 HF	
	125 Xenter	12 - 18	208 CT	2209
BWs	125	10 - 11	208 CT	2209
GPD	125 N-Max	15 - 18	226 CT	227 CT
MW	125 Tricity Left/Rear	14 - 18	222 CT	225 CT
MW	125 Tricity Right	14 - 18	223 CT	
NXC	125 Cygnus	10 - 11	207 CT	2209
NXC	125 Cygnus X	05 - 09	190 CT	2209
TT-R	125	00 - 13	2028	2028
TT-R	125 LW	00 - 18	589 SI	2028
TW	125	99 - 07	728 HF	2028
TY	125	80 - 82	2032	2034
TZ	125	97 - 00	624 DC	659 RQ
WR	125	91 - 97	611 SI	632 SI



**RECOMMENDED**

1xx = Scooter Pads  
5xx = Street, Off Road & Racing Pads  
2xxx = Brake Shoes



YAMAHA				
WR	125	98 - 02	694 SI	604 SI
WR	125 R, XY	09 - 16	627 HF	675 HF
XC	125 Beluga	85	2034	2034
XC	125 Beluga, Riva	87 - 92	2115	2034
XC	125 Cygnus F	00 - 08	107 CT	2034
XC	125 F	00 - 08	107 CT	2034
XC	125 TR Cygnus, R	96 - 98	107 CT	2034
XC	125 Vity	08 - 13	858 HF	
XQ	125 Maxter	01 - 05	151 CT*	157 CT
XT	125	82 - 86	2034	2028
YBR	125	06 - 07	575 HF	2034
YBR	125	08 - 16	858 HF	2199
YFA	125 1 D, E Breeze	92 - 93	2028	2034
YFA	125 1 F Breeze	94	2028	2034
YFA	125 1 G-M Breeze	95 - 07	2028	2034
YFA	125 1 W, A, B Breeze	89 - 91	2028	2034
YFM	125 Grizzly	04 - 13	2028	2034
YP	125 Majesty	01 - 11	151 CT	157 CT
YP	125 X-Max	06 - 09	194 CT	157 CT
YP	125 X-Max	10 - 18	181 CT	157 CT
YP	125 X-Max ABS	11 - 16	181 CT	155 CT
YP	125 X-Max Business ABS	11 - 13	181 CT	155 CT
YP	125 X-Max Sport Ed.	11 - 13	181 CT	157 CT
YT	125 Tri Moto	80 - 81		617 HF
YT	125 Tri Moto	82 - 85		576 HF
YW	125 Z	10 - 11	208 CT	2209
YW	125 Zuma	09 - 11	208 CT	
YZ	125	74 - 75	2032	2034
YZ	125	76 - 82	2033	2034
YZ	125	83	2033	2049
YZ	125	84	2036	2049
YZ	125	85 - 87	580 SI	2049
YZ	125	88	580 RSI	575 RSI
YZ	125	89	611 RSI	584 RSI
YZ	125	90 - 95	611 RSI	632 RSI
YZ	125	96 - 97	611 RSI	648 RSI
YZ	125	98 - 02	694 RSI	604 RSI
YZ	125	03 - 07	694 RSI	790 RSI
YZ	125	08 - 18	840 RSI	790 RSI
	135 Crypton X	08 - 14	858 HF	2034
	150 Xenter	12 - 18	208 CT	2209
XC	150 Fly One R	98 - 02	107 CT	2028
XQ	150 Maxter	01 - 02	151 CT*	157 CT
YP	150 Majesty	01 - 02	151 CT	157 CT
GPD	155 N-Max	15 - 18	226 CT	227 CT
XC	155 S-Max	15 - 18	181 CT	175 CT
DT	175	95 - 99	2034	2034
DT	175	00	728 HF	2034
DT	175 all models	74 - 83	2034	2034
IT	175	80 - 82	2033	2034
TY	175	77 - 80	2032	2034
YT	175 Tri Moto	82 - 83	2028	576 HF
RT	180	90 - 93	596 HF	2034
RT	180	95 - 96	575 SI	2034
XC	180 Cygnus, Riva	83 - 85	2115	2037
SR	185 Exiter, H, J	81 - 82	2034	2028
BW	200	85 - 88	2028	2028
IT	200	84 - 85	2049	2049
IT	200	86	580 HF	2049
RD	200 A, B	74 - 75	2113	2037
TT	200	86 - 89	575 HF	2028
TW	200	87 - 00	2034	2028
TW	200	01 - 15	728 HF	2028
WR	200	91 - 92	611 SI	632 SI
XC	200 Riva	87 - 91	2115	2034
XT	200	85 - 95	2034	2028
YFM	200 DXS-DXW Moto 4	86 - 87	2028	576 HF
YFM	200 N Moto 4	85 - 89	2028	576 HF

\* = 2 sets required / 2 jeux pour l'Avant.

Full compound selection, see under "Brake pad 1:1 Drawings" / Sélection complète de composés, voir "1:1 Schémas Plaquettes de frein".  
For ABE type approvals, see page 1 / Pour les homologations de type ABE, voir page 2.

**RECOMMENDED**1xx = Scooter Pads  
5xx = Street, Off Road & Racing Pads  
2xxx = Brake Shoes

YAMAHA				
YFS	200 R Blaster	03 - 06	536 SI*	592 SI
YFS	200 U-P Blaster	88 - 02	2028	637 SI
YTM	200 EK, EL Tri Moto	83 - 84	2028	576 HF
YTM	200 ERN Tri Moto	85	2028	576 HF
YTM	200 K-N Tri Moto	83 - 85	2028	576 HF
TT	225 S,T	86 - 00	575 HF	2028
TTR	225	01 - 04	575 SI	2028
XT	225	92 - 00	575 HF	2028
XT	225	01	728 HF	2028
XT	225 Serow	86	575 HF	2028
YFM	225 Moto 4	86 - 88	2028	576 HF
YTM	225 DRN, DRS Tri Moto	85 - 86	2028	576 HF
YTM	225 DXK, DXN Tri Moto	83 - 85	2028	576 HF
TT-R	230	05	611 SI	2034
	250 Morphus	06	170 MS	169 MS
DT	250 all models	75 - 80	2035	2037
FZ	250 Phazer N, S	85 - 86	555 HF*	2034
FZ	250 R	85	570 HF	
IT	250	80 - 82	2033	2037
IT	250	84	2036	2037
IT	250	85 - 86	575 SI	2037
RD	250	73 - 77	504 HF	2064
SR	250 SE	80 - 82	2035	2034
SRX	250 T, TC	87	570 HF	2037
TT	250	87 - 92	580 HF	2034
TT	250	93 - 03	611 SI	632 SI
TY	250	77 - 78	2032	2034
TY	250	81	2033	2037
TY	250	84 - 90	2049	2032
TY	250 R	91 - 92	559 HF	2032
TY	250 Z	93 - 96	559 HF	559 HF
TZ	250	02 - 05	624 DC*	659 RQ
TZ	250	82 - 85	504 HF	
TZ	250	90 - 01	624 DC*	659 RQ
WR	250	90 - 97	611 SI	632 SI
WR	250	98 - 02	694 SI	604 SI
WR	250 F	01 - 02	694 SI	604 SI
WR	250 F	03 - 13	694 SI	790 SI
WR	250 F Efi	15 - 17	694 SI	790 SI
WR	250 F Efi	18 -	840 SI	790 SI
WR	250 F Enduro GP	18 -	840 SI	790 SI
WR	250 R	08 - 15	694 HS	790 LS
WR	250 X	08 - 16	627 HS	790 LS
XG	250 Tricker	05 - 11	728 HF	632 HF
XS	250 C	77 - 78	507 HF	507 HF
XS	250 C	81	2113	2066
XS	250 D, E	79 - 80	507 HF	2066
XS	250 SE, SF	80 - 81	528 HF	2066
XT	250	80 - 81	2034	2034
XT	250	08	728 HF	632 HF
XV	250 Route 66	88 - 90	550 HF	2034
XV	250 Route 66	95 - 97	691 HF	2034
XV	250 S Virago	95 - 07	691 HS	2034
XV	250 Virago	88	550 HF	2034
XV	250 Virago	89 - 94	616 HF	2034
XVS	250 V-Star	08 - 12	691 HS	2034
XVS	250 V-Star	13 - 14	691 HS	
YBR	250	07 - 11	638 HF	
YFB	250 Timberwolf	92 - 94	2028	2035
YFB	250 Timberwolf	95 - 96	2035	2035
YFB	250 Timberwolf 4WD	94 - 03	2035	2035
YFM	250	89 - 91	2035	576 SI
YFM	250 AN Bruin 2x4	05 - 07	536 SI*	
YFM	250 Bear Tracker	01 - 04	536 SI*	
YFM	250 Raptor Left/Rear	09 - 14	850 SI	592 SI
YFM	250 Raptor Right	09 - 14	849 SI	
YFM	250 Timberwolf			
	(YFB 250 G)	95	2035	2035

**RECOMMENDED**1xx = Scooter Pads  
5xx = Street, Off Road & Racing Pads  
2xxx = Brake Shoes

YAMAHA				
YFU1TW	250 Pro Hauler	89	2035	2177
YFU1W	250 Pro Hauler	89 - 90	2035	2177
YP	250 D Majesty DX	98 - 00	128 MS	155 MS
YP	250 Majesty	96 - 04	128 MS	2066
YP	250 Majesty DX/ABS	99 - 14	128 MS	155 MS
YP	250 X-Max	05 - 09	194 MS	155 MS
YP	250 X-Max	10 - 13	181 MS	155 MS
YP	250 X-Max	14 - 16	181 MS	221 MS
YTZ	250 Tri Moto	85 - 86	575 SI	575 SI
YZ	250	74 - 79	2033	2035
YZ	250	80	2033	2034
YZ	250	81	2033	2037
YZ	250	82 - 84	2036	2034
YZ	250	85 - 87	580 SI	2034
YZ	250	88	580 RSI	575 RSI
YZ	250	89	611 RSI	584 RSI
YZ	250	98 - 02	694 RSI	604 RSI
YZ	250	03 - 07	694 RSI	790 RSI
YZ	250	08 - 18	840 RSI	790 RSI
YZ	250 A	90	611 RSI	632 RSI
YZ	250 B1-J1	91 - 97	611 RSI	648 RSI
YZ	250 F	01 - 02	694 RSI	604 RSI
YZ	250 F	03 - 06	694 RSI	790 RSI
YZ	250 F	07 - 13	840 RSI	790 RSI
YZ	250 F Efi	14 - 18	840 RSI	790 RSI
YZ	250 FX Efi	15	840 SI	790 SI
YZ	250 WRA,WRB	90 - 91	611 RSI	632 RSI
YZ	250 X	16 - 17	840 SI	790 SI
YFM	300 Warrior	89	536 SI	584 SI
YP	300 X-Max	17 - 18	229 CT	230 CT
YZF	321 R3	15 - 18	931 HS	932 HF
BW	350	87 - 88	2049	2032
RD	350	73 - 79	504 HF	2064
RZ	350	84 - 85	550 HF*	555 HF
TT	350	86 - 87	580 SI	2034
TT	350	95 - 00	611 SI	632 SI
TY	350	86	2049	2032
XT	350	85 - 96	575 HF	2034
YFM	350 Big Bear Special Edition	99	2178	2066
YFM	350 Bruin 2x4, 4x4	04 - 07	536 SI*	
YFM	350 ERT, ERU	87 - 88	2028	576 HF
YFM	350 ERW, ERA-G	89 - 95	2035	576 HF
YFM	350 FWB L, LC Big Bear	99	536 SI*	2066
YFM	350 FWH, FWJ, FWK Big Bear	96 - 98	2178	2066
YFM	350 FWT, FWU Big Bear	87 - 88	2114	576 HF
YFM	350 FWW, FWA-G Big Bear	89 - 95	2178	576 HF
YFM	350 FXG-FXM Wolverine	95 - 11	536 SI*	592 SI
YFM	350 R Raptor	04 - 14	592 SI*	592 SI
YFM	350 UH, UJ, UK	96 - 98	2178	2066
YFM	350 XG,XH Warrior	95 - 96	536 SI*	592 SI
YFM	350 XT, XU Warrior	87 - 88	575 SI*	592 SI
YFM	350 XW, XA-M Warrior	89 - 07	536 SI*	536 SI
YFP	350 U Terrapro	88	2035	2177
YFZ	350 Banshee	87 - 89	575 SI*	592 SI
YFZ	350 Banshee	90 - 06	536 SI*	592 SI
XS	360 B	76	504 HF	2064
XS	360 C, D	77	507 HF	507 HF
DT	400 all models	75 - 77	2035	2037
FZR	400	88 - 90	590 HS*	570 LS
FZR	400 A	90	613 HS	570 LS
RD	400	77	504 HF	504 HF
RD	400	78 - 79	528 HF	528 HF
RD	400	79	507 HF*	528 HF
SR	400	14 - 16	663 HS	
WR	400 F	98	694 SI	648 SI

\* = 2 sets required / 2 jeux pour l'Avant.





**RECOMMENDED**

1xx = Scooter Pads  
5xx = Street, Off Road & Racing Pads  
2xxx = Brake Shoes



YAMAHA				
WR	400 F	99 - 00	694 SI	604 SI
XJ	400 S Seca II	93	663 HS	570 LS
XS	400	77	507 HF	507 HF
XS	400	78 - 81	2113	2066
XS	400	82 - 83	550 HF	2066
XS	400	85	550 HF	2066
XS	400 DOHC	82	550 HF	2066
XS	400 SE Left/Rear	80 - 81	528 HF	2066
XS	400 SE Right	80 - 81	545 HF	
XS	400 SG, SH, SF	80 - 81	528 HF	2066
XS	400 Z	83	555 HF	555 HF
YFM	400 FAM Kodiak	00 - 02	536 SI*	754 SI
YFM	400 FAR Kodiak Automatic	03	536 SI*	2066
YFM	400 FWN Big Bear 4WD	00 - 11	536 SI*	754 SI
YFM	400 FWNH Big Bear-Buckmaster 4WD	00 - 11	536 SI*	754 SI
YFM	400 Kodiak	93 - 99	2178	2066
YFM	400 N Big Bear 2WD	00 - 11	536 SI*	754 SI
YP	400 Majesty	04	170 MS	185 MS
YP	400 Majesty	05 - 13	128 MS*	185 MS
YP	400 R X-Max	13 - 16	181 MS	195 MS
YP	400 RA X-Max	14 - 16	181 MS	195 MS
YZ	400	77 - 79	2033	2035
YZ	400	98	694 RSI	648 RSI
YZ	400 F	99	694 RSI	604 RSI
IT	425	80	2033	2035
WR	426 F	01 - 02	694 SI	604 SI
YZ	426 F	00 - 02	694 RSI	604 RSI
WR	450 F	03 - 15	694 SI	790 SI
WR	450 F Efi	16 - 18	840 SI	790 SI
WR	450 F Enduro GP	18 -	840 SI	790 SI
YFM	450 FA_ Kodiak	03 - 07	536 SI*	754 SI
YFM	450 Wolverine	06 - 10	536 SI*	754 SI
YFZ	450 S Left/Rear	04 - 05	638 SI	592 SI
YFZ	450 S Right	04 - 05	611 SI	
YFZ	450 S Left/Rear	06 - 09	638 SI	709 SI
YFZ	450 S Right	06 - 09	611 SI	
YXR	450 Rhino Left/Rear	06 - 09	611 SI	816 SI
YXR	450 Rhino Right	06 - 09	638 SI	
YZ	450 F	03 - 07	694 RSI	790 RSI
YZ	450 F	08 - 09	840 RSI	790 RSI
YZ	450 F Efi	10 - 17	840 RSI	790 RSI
YZ	450 F Efi	18 -	840 RSI	790 RSI
YZ	450 FX Efi	16	840 SI	790 SI
IT	465	81 - 82	2036	2037
YZ	465	80	2036	2035
YZ	465	81	2036	2037
IT	490	84	2036	2037
YZ	490	81 - 82	2036	2037
YZ	490	83	2036	2034
YZ	490	84	2036	2037
YZ	490	85 - 90	580 SI	2037
IT	500 G, H.	80 - 81	2033	2035
SR	500	78 - 84	507 HF	2037
TX	500 A, B	74 - 77	504 HF	2063
WR	500 B	91	611 SI	575 SI
WR	500 ZD,ZE	92 - 93	611 SI	632 SI
XP	500 TMAX	01 - 03	170 MS	169 MS
XP	500 TMAX	04 - 07	128 MS*	185 MS
XP	500 TMAX	08 - 11	198 MS*	185 MS
XP	500 TMAX Tech Max	11	198 MS*	185 MS
XS	500	75 - 77	504 HF*	2063
XS	500	77 - 81	507 HF	507 HF
XT	500	76 - 80	2035	2037
XV	500 K, Virago	83	550 HF	2063
XV	500 SE	83	550 HF	2063
XP	530 TMAX	12 - 18	198 MS*	169 MS
XP	530 TMAX DX	17 - 18	198 MS*	169 MS



**RECOMMENDED**

1xx = Scooter Pads  
5xx = Street, Off Road & Racing Pads  
2xxx = Brake Shoes



YAMAHA				
XP	530 TMAX Iron Max	15 - 18	198 MS*	169 MS
XP	530 TMAX SX	17 - 18	198 MS*	169 MS
XV	535 DX Virago	98 - 03	663 HS	2065
XV	535 S Virago	96 - 03	663 HS	2065
XV	535 Virago	87 - 94	616 HF	2065
XV	535 Virago	95 - 97	663 HS	2065
XJ	550 Maxim	81 - 83	547 HF	2063
XJ	550 Seca	81 - 83	547 HF	2066
XT	550	82 - 83	2037	2037
XZ	550	82	547 HF*	2063
XZ	550	83 - 84	550 HF*	2063
XZ	550 Rj, RK	82 - 83	550 HF	2063
XZ	550 S	83 - 84	550 HF*	2063
YFM	550 FGPW Grizzly Left	09 - 16	850 SI	852 SI
YFM	550 FGPW Grizzly Right	09 - 16	849 SI	851 SI
FJ	600	84 - 85	555 HF*	555 HF
FZ	600	86 - 87	555 HF*	555 HF
FZ	600 S, SC	86 - 89	555 HF*	570 HF
FZ6	600	04 - 08	691 HS*	657 LS
FZ6	600 Fazer	04 - 08	691 HS*	657 LS
FZ6	600 Fazer S2	07 - 09	634 HS*	657 LS
FZ6	600 Fazer S2 ABS	07 - 09	634 HS*	657 LS
FZ6	600 S2	07 - 09	634 HS*	657 LS
FZ6	600 S2 ABS	07 - 09	634 HS*	657 LS
FZ6R	600	09 - 14	691 HS*	614 LS
FZR	600	89	555 HF*	555 HF
FZR	600 R	90 - 91	645 HS*	555 LS
FZR	600 R	92 - 95	665 HS*	555 LS
FZS	600 Fazer	98 - 03	634 HS*	570 LS
FZS	600 S Fazer	01 - 03	634 HS*	570 LS
SRX	600	86 - 87	570 HF*	570 HF
TT	600	85 - 88	575 HF	2034
TT	600 K,L	83 - 84	2036	2034
XJ	600 SECA II	92 - 96	663 HS	570 LS
XT	600	83 - 86	550 HF	2037
YFM	600 4x4 Grizzly	98 - 01	592 SI*	2066
YX	600 Radian	87 - 90	555 HF*	2063
YZF	600 R	94 - 96	645 HS*	555 LS
YZF	600 R Thunder Cat	96 - 03	634 HS*	555 LS
YZF	600 R6	99 - 02	634 HS*	728 LS
YZF	600 R6	03 - 16	634 HS*	657 LS
YZF	600 R6	17 - 18	634 HS*	834 LS
TX	650	72 - 73	504 HF	
XJ	650	80 - 82	507 HF*	2065
XJ	650	83	550 HF	2065
XJ	650 G, H, SH Left/Rear	80 - 83	545 HF	2065
XJ	650 G, H, SH Right	80 - 83	528 HF	
XJ	650 Seca	81 - 83	547 HF*	2065
XJ	650 Turbo	81 - 82	550 HF*	2065
XS	650	75 - 77	504 HF*	2064
XS	650	75 - 85	507 HF*	507 HF
XS	650	77 - 79	507 HF*	2064
XS	650	80 - 82	545 HF	507 HF
XS	650 SE	80 - 82	507 HF	507 HF
XS	650 SJ, SK	82	507 HF*	2064
XS	650 SK, Heritage	83	507 HF*	507 HF
XVS	650 V-Star	09 - 14	663 HS	769 LS
XVS	650 V-Star Classic	98 - 06	663 HS	2065
XVS	650 V-Star Custom	98 - 06	663 HS	2065
XVS	650 V-Star Tourer	09 - 14	663 HS	769 LS
	660 Rhino Left/Rear	05 - 08	611 SI	816 SI
	660 Rhino Right	05 - 08	638 SI	
XT	660 R	04 - 11	674 HS	675 LS
XT	660 X	04 - 13	706 HS	675 LS
XT	660 Z Tenere	08 - 14	671 HS*	675 LS
XT	660 Z Tenere ABS	11 - 14	671 HS*	675 LS
YFM	660 FWAP 4x4 Grizzly	02 - 08	592 SI*	799 SI
YFM	660 RN Raptor	01 - 09	592 SI*	592 SI

\* = 2 sets required / 2 jeux pour l'Avant.

Full compound selection, see under "Brake pad 1:1 Drawings" / Sélection complète de composés, voir "1:1 Schémas Plaquettes de frein".  
For ABE type approvals, see page 1 / Pour les homologations de type ABE, voir page 2.

**RECOMMENDED**

1xx = Scooter Pads  
5xx = Street, Off Road & Racing Pads  
2xxx = Brake Shoes



YAMAHA					
FZ	700	87 - 88	555 HF*	555 HF	
FZ-07	700	14 - 17	634 HS*	657 LS	
FZX	700 Fazer	87 - 88	555 HF	555 HF	
MT-07	700	18 -	634 HS*	657 LS	
XJ	700	86 - 89	555 HF	2065	
XJ	700 Maxim	85 - 89	555 HF	555 HF	
XV	700 L, LC	84 - 87	555 HF*	2065	
XV	700 Virago	87	555 HF	2065	
YFM	700 FGPW Grizzly Left	07 - 17	850 SI	852 SI	
YFM	700 FGPW Grizzly Right	07 - 17	849 SI	851 SI	
YFM	700 R Raptor Left/Rear	06 - 08	611 SI	816 SI	
YFM	700 R Raptor Right	06 - 08	638 SI		
YFM	700 Raptor	09 - 12	611 SI	816 SI	
YFM	700 Raptor	09 - 12	638 SI		
YFM	700 Raptor	13 - 14	611 SI	709 SI	
YFM	700 Raptor	13 - 14	638 SI		
YXR	700 Rhino Left	08 - 14	638 SI	638 SI	
YXR	700 Rhino Right	08 - 14	611 SI	611 SI	
	750 Maxim	81	547 HF	555 HF	
FZ	750	85 - 86	555 HF*	555 HF	
FZ	750 Genesis	86	555 HF*	570 HF	
FZ	750 Genesis	87 - 88	555 HF*	555 HF	
FZ	750 Genesis	89 - 92	590 HS*	555 LS	
FZR	750 R	89 - 92	624 HS*	555 LS	
FZR	750 R Genesis	87 - 88	613 HF*	555 HF	
FZX	750 Fazer	86 - 90	555 HF*	555 HF	
TX	750	73 - 74	504 HF*	2065	
TX	750 A	73 - 76	504 HF*	555 HF	
VF	750 Virago	88	555 HF	2065	
XJ	750	83 - 87	555 HF*	555 HF	
XJ	750 E	81 - 83	507 HF	2065	
XJ	750 Maxim	82	550 HF*	2065	
XJ	750 Seca	81 - 83	547 HF*	2065	
XS	750	77 - 80	507 HF*	507 HF	
XS	750 H, J, K	81 - 82	545 HF	507 HF	
XS	750 SE Left/Rear	79 - 80	545 HF	507 HF	
XS	750 SE Right	79 - 80	528 HF		
XV	750	89 - 92	555 HS	2065	
XV	750 MK	83	528 HF	2063	
XV	750 SE	81 - 83	545 HF	2063	
XV	750 Virago	93 - 97	555 HS*	2065	
YZF	750 R, SP	93 - 97	683 HS*	555 LS	
YZF	750 R7 OW02	99 - 02	634 HS*	733 LS	
YZF	750 R7 OW02 Race kit	99 - 01	729 HS*		
	800 Fazer 8	10 - 15	634 HS*	657 LS	
FZ8	800	10 - 14	634 HS*	657 LS	
FJ-09	850	15 - 17	634 HS*	657 LS	
FZ-09	850	14 - 17	634 HS*	657 LS	
MT-09	850	18 -	634 HS*	657 LS	
TDM	850	91 - 95	590 HS*	555 LS	
XS	850	80 - 81	507 HF*	507 HF	
XS	850 Left/Rear	81	545 HF	507 HF	
XS	850 Right	81	528 HF		
	900 Niken	18 -	634 HS*		
XJ	900	83 - 84	555 HF*	555 HF	
XSR	900	16 - 18	634 HS*	657 LS	
XSR	900 Abarth	17 - 18	634 HS*	657 LS	
XV	920	81 - 82	507 HF		
XV	920 J	82	547 HF	2065	
XV	920 K, MK, Virago	83	545 HF	550 HF	
SCR	950 Scrambler	17 - 18	663 HS	769 LS	
XV	950 Bolt	14 - 18	663 HS	769 LS	
XV	950 Bolt C-Spec	15 - 18	663 HS	769 LS	
XV	950 Bolt Racer	17 - 18	663 HS	769 LS	
XV	950 Bolt R-Spec	14 - 18	663 HS	769 LS	
XVS	950 A Midnight Star	09 - 13	663 HS	769 LS	
FZ1	1000 Fazer	06 - 16	634 HS*	657 LS	
FZ-10	1000	16 - 17	634 HS*	657 LS	

**RECOMMENDED**

1xx = Scooter Pads  
5xx = Street, Off Road & Racing Pads  
2xxx = Brake Shoes



YAMAHA					
FZR	1000	94 - 95	683 HS*	555 LS	
FZR	1000 EX UP	90 - 91	645 HS*	555 LS	
FZR	1000 EX UP	92 - 93	665 HS*	555 LS	
FZR	1000 Genesis	87 - 89	613 HF*	555 HF	
FZS	1000 Fazer	01 - 05	634 HS*	770 LS	
GTS	1000	93 - 99	682 HF	555 HF	
MT-10	1000	18 -	634 HS*	657 LS	
XV	1000 L, C	84 - 85	555 HF*	555 HF	
YZF	1000 R Thunder Ace	96 - 99	634 HS*	555 LS	
YZF	1000 R1	98 - 01	634 HS*	733 LS	
YZF	1000 R1	02 - 03	634 HS*	728 LS	
YZF	1000 R1	04 - 06	634 HS*	657 LS	
YZF	1000 R1(4-pad)	07 - 14	839 SP*	657 LS	
YZF	1000 R1(4-pad) ABS	12 - 14	839 SP*	657 LS	
YZF	1000 R1	15 - 18	634 SP*	834 LS	
YZF	1000 R1 LE	06	634 HS*	657 LS	
YZF	1000 R1M	15 - 18	634 SP*	834 LS	
YZF	1000 R1S	16	634 SP*	834 LS	
	1100 SE, Maxim	81	547 HF		
BT	1100 Bulldog	02 - 06	634 HS*	555 LS	
FJ	1100	83 - 85	555 HF*	555 HF	
XJ	1100	81	547 HF*	528 HF	
XS	1100 E,F,G,H	78 - 81	507 HF*	507 HF	
XS	1100 LH Midnight	81	547 HF*	528 HF	
XS	1100 SF, SG, SH, LG				
	Left/Rear	79 - 81	545 HF	507 HF	
XS	1100 SF, SG, SH, LG Right	79 - 81	528 HF		
XV	1100	94 - 97	555 HS*	2065	
XV	1100 Virago	86 - 93	555 HF*	2065	
XVS	1100 V-Star	99 - 06	691 HS*	555 LS	
XVS	1100 V-Star Classic	00 - 06	691 HS*	555 LS	
FJ	1200	86 - 87	555 HF*	555 HF	
FJ	1200	88 - 90	613 HF*	555 HF	
FJ	1200 ABS	91 - 93	613 HS*	555 LS	
V-MAX	1200	85 - 89	555 HF*	555 HF	
V-MAX	1200	90 - 92	555 HS*	555 LS	
V-MAX	1200	93 - 03	645 HS*	555 LS	
XT	1200 Z Super Tenere	14 - 18	634 SP*	769 LS	
XT	1200 ZE Super Tenere	14 - 18	634 SP*	769 LS	
XT	1200 ZE Super Tenere				
	Raid Ed.	18 -	634 SP*	769 LS	
XTZ	1200 Super Tenere	10 - 13	634 HS*	769 LS	
XV	1200	84 - 87	555 HF*	555 HF	
XV	1200 Venture Royale	85	555 HF*	555 HF	
XV	1200 Z12T	84 - 87	555 HF*	555 HF	
XVT	1200 T, Vent. Royale	84 - 85	555 HF*	555 HF	
FJR	1300	01 - 03	634 HS*	769 LS	
FJR	1300 A	13 - 18	740 HS*	769 LS	
FJR	1300 ABS	03 - 05	634 HS*	769 LS	
FJR	1300 ABS	06 - 12	740 HS*	769 LS	
FJR	1300 AE	16 - 18	740 HS*	769 LS	
FJR	1300 AS	13 - 18	740 HS*	769 LS	
XJR	1300	02 - 18	634 HS*	770 LS	
XJR	1300 Racer	15 - 18	634 HS*	770 LS	
XJR	1300 SP	01	634 HS*	555 LS	
XVS	1300 A Midnight Star	07 - 11	691 HS*	769 LS	
XVS	1300 Custom	14 - 16	691 HS	769 LS	
XVS	1300 Stryker	11 - 14	663 HS	769 LS	
XVS	1300 Stryker Bullet Cowl	15	663 HS	769 LS	
XVS	1300 V-Star	07 - 14	691 HS*	769 LS	
XVS	1300 V-Star Deluxe	07 - 14	691 HS*	769 LS	
XVS	1300 V-Star Tourer	07 - 14	691 HS*	769 LS	
XVZ	1300 A Royal Star	96 - 07	613 HS*	590 LS	
XVZ	1300 AT Royal Star Tour				
	Classic	97 - 07	613 HS*	590 LS	
XVZ	1300 Royal Star Boulevard	99 - 01	613 HS*	590 LS	
XVZ	1300 Royal Star Venture S	08 - 13	663 HS*	590 LS	
XVZ	1300 TF Royal Star Venture	99 - 01	663 HS*	590 LS	

\* = 2 sets required / 2 jeux pour l'Avant.

Full compound selection, see under "Brake pad 1:1 Drawings" / Sélection complète de composés, voir "1:1 Schémas Plaquettes de frein".  
For ABE type approvals, see page 1 / Pour les homologations de type ABE, voir page 2.







# MOTOCROSS



Photographer: Ray Archer



## COMPOUND CHOICE

## COMPOUND CHOICE



APRILIA					RSI	SI	CS		RSI	SI	CS
MXV	450	09 - 13	694	△	△	△		790	△	△	△
<b>BENELLI</b>											
BX	449 Cross	07 - 09	671	△	△	△		675	△	△	△
<b>CCM</b>											
	450 MX	08 - 10	671	△	△	△		790	△	△	△
<b>GAS GAS</b>											
MC	125	03 - 13	694	△	△	△		604	△	△	△
MC	250	97 - 99	671	△	△	△		675	△	△	△
<b>HONDA</b>											
CR	80 R, RB	92 - 02	584	△	△			604	△	△	△
CR	85 R, R Expert	03 - 12	592	△	△	△		604	△	△	△
CR	125 R	95 - 01	694	△	△	△		604	△	△	△
CR	125 R	02 - 07	694	△	△	△		777	△	△	△
CR	125 RH, RJ, RK	87 - 94	603	△	△			604	△	△	△
CRF	150 R	07 - 18	592	△	△	△		777	△	△	△
CRF	250 R	04 - 09	694	△	△	△		777	△	△	△
CRF	250 R Efi	10 - 17	694	△	△	△		777	△	△	△
CRF	250 R Efi	18 -	694	△	△	△		777	△	△	△
CR	250 R	87 - 94	603	△	△			604	△	△	△
CR	250 R	95 - 01	694	△	△	△		604	△	△	△
CR	250 R	02 - 07	694	△	△	△		777	△	△	△
CRF	450 R	02 - 08	694	△	△	△		777	△	△	△
CRF	450 Efi	09 - 12	694	△	△	△		777	△	△	△
CRF	450 R Efi	13 - 18	694	△	△	△		777	△	△	△
CRF	450 RX Efi	17 - 18	694	△	△	△		777	△	△	△
CR	500 R	87 - 94	603	△	△			604	△	△	△
CR	500 R	95 - 01	694	△	△	△		604	△	△	△
<b>HUSABERG</b>											
FC	400	99 - 02	671	△	△	△		675	△	△	△
FC	450	03 - 08	671	△	△	△		675	△	△	△
FC	470 , e	01 - 02	671	△	△	△		675	△	△	△
FC	501	99 - 01	671	△	△	△		675	△	△	△
FC	550	01 - 05	671	△	△	△		675	△	△	△
FC	600	99 - 01	671	△	△	△		675	△	△	△
<b>HUSQVARNA</b>											
CR	65	12 - 13	783	△	△	△		872	△	△	△
TC	65	17 - 18	783	△	△	△		783	△	△	△
TC	85	14 - 18	885	△	△	△		872	△	△	△
TC	125	14 - 18	671	△	△	△		791	△	△	△
CR	125	05 - 13	671	△	△	△		791	△	△	△
CR	250	96 - 04	671	△	△	△		675	△	△	△
CR	250	05	671	△	△	△		791	△	△	△
FC	250	14 - 18	671	△	△	△		791	△	△	△
TC	250	02 - 03	671	△	△	△		675	△	△	△
TC	250	04 - 13	671	△	△	△		791	△	△	△
TC	250	14 - 18	671	△	△	△		791	△	△	△
TC	300	14 - 15	671	△	△	△		791	△	△	△
FC	350	14 - 18	671	△	△	△		791	△	△	△
TC	449	11 - 13	671	△	△	△		791	△	△	△
TC	450	02 - 03	671	△	△	△		675	△	△	△
TC	450	04 - 10	671	△	△	△		791	△	△	△
FC	450	14 - 18	671	△	△	△		791	△	△	△
TC	510	02 - 03	671	△	△	△		675	△	△	△
TC	510	04 - 10	671	△	△	△		791	△	△	△
TC	570	01 - 13	671	△	△	△		675	△	△	△
TC	610	96 - 13	671	△	△	△		675	△	△	△
<b>KAWASAKI</b>											
KX	65	00 - 15	752	△	△	△		536	△	△	
KX	80	88 - 96	544	△	△	△		592	△	△	△
KX	80	97 - 00	726	△	△	△		592	△	△	△
KX	85	01 - 18	726	△	△	△		592	△	△	△

△ = Available quality / Qualité disponible.

To select compound for off-road front/rear - see page 23-25 / Pour sélectionner vos plaquettes off-road avant/arrière - voir page 23-25.





KAWASAKI			COMPOUND CHOICE				COMPOUND CHOICE			
				RSI	SI	CS		RSI	SI	CS
KX 85 II	01 - 13	726	△	△	△	592	△	△	△	
KX 100	88 - 96	544	△	△	△	592	△	△	△	
KX 100	97 - 18	726	△	△	△	592	△	△	△	
KX 125	86	546	△	△		586	△	△		
KX 125	89 - 93	611	△	△		632	△	△		
KX 125	94	694	△	△	△	632	△	△		
KX 125	95 - 08	694	△	△	△	604	△	△	△	
KX 250	86	546	△	△		586	△	△		
KX 250	89 - 93	611	△	△		632	△	△		
KX 250	94	694	△	△	△	632	△	△		
KX 250	95 - 08	694	△	△	△	604	△	△	△	
KX-F 250	04 - 10	694	△	△	△	790	△	△	△	
KX-F 250 DFI	11 - 18	694	△	△	△	790	△	△	△	
KX-F 450	06 - 08	694	△	△	△	790	△	△	△	
KX-F 450 DFI	09 - 18	694	△	△	△	790	△	△	△	
KX 500	86	546	△	△		586	△	△		
KX 500	89 - 93	611	△	△		632	△	△		
KX 500	94 - 95	694	△	△	△	632	△	△		
KX 500	96 - 04	694	△	△	△	604	△	△	△	
<b>KTM</b>										
SX 60	99	559	△	△	△					
SX 65	00 - 01	559	△	△	△	574	△	△	△	
SX 65	02 - 03	783	△	△	△	574	△	△	△	
SX 65	04 - 08	783	△	△	△	794	△	△		
SX 65	09 - 18	783	△	△	△	783	△	△	△	
SX 85 (19"/16" wheels)	13 - 18	885	△	△	△	872	△	△	△	
SX 85	04 - 10	783	△	△	△	783	△	△	△	
SX 85	11	783	△	△	△	872	△	△	△	
SX 85	12 - 18	885	△	△	△	872	△	△	△	
SX 125	96 - 03	671	△	△	△	675	△	△	△	
SX 125	04 - 18	671	△	△	△	791	△	△	△	
SX 144	07 - 08	671	△	△	△	791	△	△	△	
SX 150	09 - 18	671	△	△	△	791	△	△	△	
SX 200	03 - 04	671	△	△	△	791	△	△	△	
SX 250	96 - 02	671	△	△	△	675	△	△	△	
SX 250	03 - 18	671	△	△	△	791	△	△	△	
SX-F 250	06 - 18	671	△	△	△	791	△	△	△	
SX-F 350	11 - 18	671	△	△	△	791	△	△	△	
SX 360	96 - 97	671	△	△	△	675	△	△	△	
SX 380	98 - 02	671	△	△	△	675	△	△	△	
SX 400 Racing	00 - 02	671	△	△	△	675	△	△	△	
XC-F 450	06 - 17	671	△	△	△	791	△	△	△	
SX-F 450	03 - 18	671	△	△	△	791	△	△	△	
XC-F 505	08 - 09	671	△	△	△	791	△	△	△	
SX 505 Racing	07 - 09	671	△	△	△	791	△	△	△	
SX-F 520 Racing	00 - 02	671	△	△	△	675	△	△	△	
SX-F 525 Racing	03	671	△	△	△	675	△	△	△	
SX-F 525 Racing	04 - 06	671	△	△	△	791	△	△	△	
SX 620	95 - 99	671	△	△	△	675	△	△	△	
<b>LEM</b>										
RX 65	05 - 10	794	△	△		794	△	△		
<b>POLINI</b>										
X5 65 RP	05 - 06	794	△	△		794	△	△		
<b>SHERCO</b>										
SX 250 2.5i-F	09 - 11	671	△	△	△	790	△	△	△	
<b>SUZUKI</b>										
RM 65	03 - 06	752	△	△	△	536	△	△		
RM 80	96 - 01	702	△	△	△	544	△	△	△	
RM 85 , L	02 - 04	702	△	△	△	544	△	△	△	
RM 85 , L	05 - 18	726	△	△	△	820	△	△	△	
RM 100	03	726	△	△	△	592	△	△	△	
RM 125	88	611	△	△		584	△	△		
RM 125	89 - 90	611	△	△		632	△	△		

△ = Available quality / Qualité disponible.

To select compound for off-road front/rear - see page 23-25 / Pour sélectionner vos plaquettes off-road avant/arrière - voir page 23-25.



## COMPOUND CHOICE

## COMPOUND CHOICE



SUZUKI					RSI	SI	CS		RSI	SI	CS
RM 125		91 - 95	611	△	△			648	△	△	
RM 125		96 - 09	694	△	△	△		604	△	△	△
RM 250		87 - 88	611	△	△			584	△	△	
RM 250		89 - 90	611	△	△			632	△	△	
RM 250		91 - 95	611	△	△			648	△	△	
RM 250		96 - 09	694	△	△	△		604	△	△	△
RMX 250		89 - 95	611	△	△			648	△	△	
RMX 250		96 - 98	694	△	△	△		648	△	△	
RM-Z 250		04 - 09	694	△	△	△		790	△	△	△
RM-Z 250 Efi		10 - 18	694	△	△	△		790	△	△	△
RM-Z 450		05 - 07	694	△	△	△		790	△	△	△
RM-Z 450 Efi		08 - 17	694	△	△	△		790	△	△	△
RM-Z 450 Efi		18 -	694	△	△	△		790	△	△	△
RM 500		87 - 89	611	△	△			592	△	△	△
<b>TM</b>											
	80 Cross	96 - 00	671	△	△	△		675	△	△	△
	80 Junior	96 - 00	544	△	△	△		592	△	△	△
MX	85	01 - 12	671	△	△	△		604	△	△	△
MX	85	13 - 18	777	△	△	△		777	△	△	△
	125	96 - 00	671	△	△	△		675	△	△	△
	125	01 - 04	671	△	△	△		604	△	△	△
	125	05 - 17	671	△	△	△		790	△	△	△
	250	01 - 04	671	△	△	△		604	△	△	△
	250	05	671	△	△	△		790	△	△	△
	250 E	95 - 00	671	△	△	△		675	△	△	△
	250 F	01 - 04	671	△	△	△		604	△	△	△
	250 F	05 - 17	671	△	△	△		790	△	△	△
	300	98 - 00	671	△	△	△		675	△	△	△
	300	01 - 04	671	△	△	△		604	△	△	△
	300	05	671	△	△	△		790	△	△	△
	320	96 - 97	671	△	△	△		675	△	△	△
	400 F	00	671	△	△	△		675	△	△	△
	400 F	01	671	△	△	△		604	△	△	△
	450 F	02 - 04	671	△	△	△		604	△	△	△
	450 F	05 - 17	671	△	△	△		790	△	△	△
	530 F	01 - 04	671	△	△	△		604	△	△	△
	530 F	05	671	△	△	△		790	△	△	△
<b>YAMAHA</b>											
YZ 80		93 - 01	589	△	△	△		592	△	△	△
YZ 85 , LW		02 - 18	589	△	△	△		592	△	△	△
YZ 125		88	580	△	△			575	△	△	
YZ 125		89	611	△	△			584	△	△	
YZ 125		90 - 95	611	△	△			632	△	△	
YZ 125		96 - 97	611	△	△			648	△	△	
YZ 125		98 - 02	694	△	△	△		604	△	△	△
YZ 125		03 - 07	694	△	△	△		790	△	△	△
YZ 125		08 - 18	840	△	△	△		790	△	△	△
YZ 250		88	580	△	△			575	△	△	
YZ 250		89	611	△	△			584	△	△	
YZ 250		98 - 02	694	△	△	△		604	△	△	△
YZ 250		03 - 07	694	△	△	△		790	△	△	△
YZ 250		08 - 18	840	△	△	△		790	△	△	△
YZ 250 A		90	611	△	△			632	△	△	
YZ 250 B1-J1		91 - 97	611	△	△			648	△	△	
YZ 250 F		01 - 02	694	△	△	△		604	△	△	△
YZ 250 F		03 - 06	694	△	△	△		790	△	△	△
YZ 250 F		07 - 13	840	△	△	△		790	△	△	△
YZ 250 F Efi		14 - 18	840	△	△	△		790	△	△	△
YZ 250 WRA,WRB		90 - 91	611	△	△			632	△	△	
YZ 400		98	694	△	△	△		648	△	△	
YZ 400 F		99	694	△	△	△		604	△	△	△
YZ 426 F		00 - 02	694	△	△	△		604	△	△	△
YZ 450 F		03 - 07	694	△	△	△		790	△	△	△
YZ 450 F		08 - 09	840	△	△	△		790	△	△	△
YZ 450 F Efi		10 - 17	840	△	△	△		790	△	△	△
YZ 450 F Efi		18 -	840	△	△	△		790	△	△	△

△ = Available quality / Qualité disponible.

# ATV / UTV







## COMPOUND CHOICE

## COMPOUND CHOICE



ADLY				HF	ATS	SI	RSI		HF	ATS	SI	RSI
	150 ATV	05 - 07	544*	△		△	△	544	△		△	△
	150 Interceptor	05 - 07	544*	△		△	△	544	△		△	△
	300 ATV	05 - 11	544*	△		△	△	544	△		△	△
	300 Cross X Over	07 - 11	810*			△	△					
	300 Cross X Road	07 - 11	810*			△	△					
ATV	300 Sport	07 - 13	810*			△	△	848	△		△	
	320 S	07 - 13	810*			△	△					
	320 U	07 - 13	810*			△	△					
ARCTIC CAT												
	50 2WD	04 - 06	2048*									
	50 DVX	06 - 08	2048*					638	△		△	△
	90 2WD	02 - 04	2048*									
	90 DVX	06 - 14	2048*					638	△		△	△
	250 2x4	05 - 06	822*		△	△	△	822		△	△	△
	250 2x4 (Man. Hand Brake)	99 - 04						827		△		
	250 2x4/4x4	99 - 04	758*		△	△	△	758		△	△	△
	250 4x4 (Man. Hand Brake)	00 - 04						827		△		
	250 DVX	06 - 09	810*	△		△	△	775	△		△	△
	300 2x4	10 - 13	822*		△	△	△	822		△	△	△
	300 2x4 (Man. Hand Brake)	98 - 04						827		△		
	300 2x4/4x4	98 - 04	758*		△	△	△	758		△	△	△
	300 4x4	05	822*		△	△	△	822		△	△	△
	300 4x4 (Man. Hand Brake)	98 - 05						827		△		
	300 DVX	09 - 16	810*	△		△	△	775	△		△	△
	375 2x4/4x4	02	758*		△	△	△	758		△	△	△
	375 2x4/4x4 (Man. Hand Brake)	02						827		△		
	400 2x4 (Man. Hand Brake)	98 - 02						827		△		
	400 2x4/4x4	98 - 04	758*		△	△	△	758		△	△	△
	400 2x4/4x4 (FIS)	02 - 04	758*		△	△	△	758		△	△	△
	400 2x4/4x4 (FIS)	05 - 07	822*		△	△	△	822		△	△	△
	400 2x4/4x4 (FIS) Aut.(Man. Hand Brake)	03 - 04						827		△		
	400 2x4/4x4 (FIS)(Man. Hand Brake)	02 - 04						827		△		
	400 2x4/4x4 (FIS)(Man. Hand Brake)	05 - 08						758		△	△	△
	400 4x4 (Man. Hand Brake)	98 - 04						827		△		
	400 DVX	04 - 08	592*	△		△	△	649	△		△	△
	400 TBX 4x4	04	758*		△	△	△	758		△	△	△
	400 TBX 4x4 (Man. Hand Brake)	04						827		△		
TRV	400	09 - 13	822*		△	△	△	822		△	△	△
	440 Bear Cat	96 - 97						758		△	△	△
	450 H1	10	822*		△	△	△	822		△	△	△
XC	450	11 - 14	822*		△	△	△	822		△	△	△
	454 Arctic Cat 4x4	98	758*		△	△	△	758		△	△	△
	454 Bear Cat 2x4/4x4	96 - 98	758*		△	△	△	758		△	△	△
	454 Bear Cat 2x4/4x4 (Man. Hand Brake)	98						827		△		
	500 2x4 (FIS)(Man. Hand Brake)	02						827		△		
	500 2x4 (Man. Hand Brake)	02						827		△		
	500 2x4/4x4	98 - 04	758*		△	△	△	758		△	△	△
	500 2x4/4x4 (FIS)	02 - 04	758*		△	△	△	758		△	△	△
	500 2x4/4x4 (FIS)	05 - 09	822*		△	△	△	822		△	△	△
	500 4x4 (FIS) Aut.(Man. Hand Brake)	02 - 03						827		△		
	500 4x4 (FIS)(Man. Hand Brake)	02 - 03						827		△		
	500 4x4 (Man. Hand Brake)	98 - 02						827		△		
	500 TBX 4x4	02 - 04	758*		△	△	△	758		△	△	△
	500 TBX 4x4	05 - 06	822*		△	△	△	822		△	△	△
	500 TBX 4x4 (Man. Hand Brake)	03 - 04						827		△		
	500 TBX 4x4 Aut.(Man. Hand Brake)	02						827		△		
	500 TRV 4x4	03 - 04	758*		△	△	△	758		△	△	△
	500 TRV 4x4	05 - 06	822*		△	△	△	822		△	△	△
	500 TRV 4x4 (Man. Hand Brake)	03 - 04						827		△		
	550 H1	09 - 13	822*		△	△	△	822		△	△	△
	550 LTD	09 - 12	822*		△	△	△	822		△	△	△
	550 Prowler	09 - 14	822*		△	△	△	822		△	△	△
TRV	550	09 - 14	822*		△	△	△	822		△	△	△
	650 H1 4x4 Aut.	05 - 11	822*		△	△	△	822		△	△	△
	650 Prowler	06 - 08	822*		△	△	△	822		△	△	△
	650 V2 4x4 Aut.	05 - 06	822*		△	△	△	822		△	△	△
	650 V2 4x4 Aut. LE	05 - 06	822*		△	△	△	822		△	△	△

\* = 2 sets required / 2 jeux pour l'Avant.

△ = Available quality / Qualité disponible.

To select compound for off-road front/rear - see page 23-25 / Pour sélectionner vos plaquettes off-road avant/arrière - voir page 23-25.



		COMPOUND CHOICE					COMPOUND CHOICE				
		HF	ATS	SI	RSI	HF	ATS	SI	RSI		
<b>ARCTIC CAT</b>											
	700 Diesel	06 - 14	822*	△	△	△	822	△	△	△	
	700 H1	09 - 10	822*	△	△	△	822	△	△	△	
	700 Prowler	08	822*	△	△	△	822	△	△	△	
	700 Wildcat Sport	15 - 18	946*	△	△	△	822	△	△	△	
	700 Wildcat Sport LTD.	16 - 18	946*	△	△	△	822	△	△	△	
	700 Wildcat Sport LTD. EPS	17 - 18	946*	△	△	△	822	△	△	△	
	700 Wildcat Sport XT	15 - 18	946*	△	△	△	822	△	△	△	
	700 Wildcat Sport XT EPS	16 - 18	946*	△	△	△	822	△	△	△	
TBX	700	12 - 14	822*	△	△	△	822	△	△	△	
TRV	700	09 - 12	822*	△	△	△	822	△	△	△	
	1000 Prowler	09	822*	△	△	△	822	△	△	△	
	1000 Thundercat	09 - 14	822*	△	△	△	822	△	△	△	
	1000 Wildcat 4X	16 - 18	912*	△	△	△	822	△	△	△	
	1000 Wildcat X	16 - 18	912*	△	△	△	822	△	△	△	
	1000 Wildcat X Ltd.	17 - 18	912*	△	△	△	822	△	△	△	
	1000 Wildcat X SE	17 - 18	912*	△	△	△	822	△	△	△	
TRV	1000	09 - 14	822*	△	△	△	822	△	△	△	
<b>ATK</b>											
ATK	604 Quadracer	90	601	△			607	△			
<b>BOMBARDIER</b>											
	50 Quest	03 - 04	2048*				2041				
DS	50	02 - 06	2048*				2041				
	90 Quest	03 - 04	2048*				2041				
DS	90	02 - 06	2048*				2041				
	200 Rally 2x4	03 - 04	544*		△	△					
	200 Rally 2x4	05 - 06	544*		△	△	546		△	△	
DS	250 Left/Rear	06	754		△	△	754		△	△	
DS	250 Right	06	767		△	△					
	330 Outlander Left/Rear	03 - 06	754		△	△	754		△	△	
	330 Outlander Right	03 - 06	767		△	△					
	400 Outlander Left/Rear	03 - 06	754		△	△	754		△	△	
	400 Outlander Max Left/Rear	03 - 06	754		△	△	754		△	△	
	400 Outlander Max Right	03 - 06	767		△	△					
	400 Outlander Right	03 - 06	767		△	△					
	500 Quest Left/Rear	02 - 06	754		△	△	754		△	△	
	500 Quest Right	02 - 06	767		△	△					
	500 Traxter 4x4	99 - 00	730*	△			730	△			
	500 Traxter 4x4 Left/Rear	01 - 06	754		△	△	767		△	△	
	500 Traxter 4x4 Right	01 - 06	767		△	△					
	500 Traxter Max Left/Rear	03 - 05	754		△	△	767		△	△	
	500 Traxter Max Right	03 - 05	767		△	△					
	650 Quest Left/Rear	02 - 06	754		△	△	754		△	△	
	650 Quest Right	02 - 06	767		△	△					
	650 Quest Max Left/Rear	03 - 06	754		△	△	767		△	△	
	650 Quest Max Right	03 - 06	767		△	△					
	650 Traxter Max Left/Rear	03 - 05	754		△	△	767		△	△	
	650 Traxter Max Right	03 - 05	767		△	△					
DS	650 Left/Rear	01 - 06	754		△	△	754		△	△	
DS	650 Right	01 - 06	767		△	△					
	800 Outlander Left/Rear	06	754		△	△	754		△	△	
	800 Outlander Right	06	767		△	△					
	800 Outlander XT Left/Rear	06	754		△	△	754		△	△	
	800 Outlander XT Right	06	767		△	△					
<b>CAN-AM</b>											
DS	50	07 - 11	2048*				2041				
DS	70	08 - 14	2048*				2041				
DS	90	07 - 18	2048*				2041				
DS	90 X	08 - 18	544*		△	△	544		△	△	
DS	250	08 - 18	810*		△	△	810		△	△	
	400 Outlander EFi Left/Rear	09 - 14	754		△	△	754		△	△	
	400 Outlander EFi Right	09 - 14	767		△	△					
	400 Outlander MAX STD Left/Rear	07 - 13	754		△	△	754		△	△	
	400 Outlander MAX STD Right	07 - 13	767		△	△					
	400 Outlander MAX XT Left/Rear	07 - 13	754		△	△	754		△	△	
	400 Outlander MAX XT Right	07 - 13	767		△	△					

Applications  
ATV/UTV

\* = 2 sets required / 2 jeux pour l'Avant.

△ = Available quality / Qualité disponible.

To select compound for off-road front/rear - see page 23-25 / Pour sélectionner vos plaquettes off-road avant/arrière - voir page 23-25.



## COMPOUND CHOICE

## COMPOUND CHOICE



CAN-AM				HF	ATS	SI	RSI		HF	ATS	SI	RSI
400	Outlander STD Left/Rear	07 - 14	754			△	△	754			△	△
400	Outlander STD Right	07 - 14	767			△	△					
400	Outlander XT Left/Rear	07 - 14	754			△	△	754			△	△
400	Outlander XT Right	07 - 14	767			△	△					
450	Outlander Left	15 - 18	911			△	△					
450	Outlander Right/Rear	15 - 18	910			△	△	910			△	△
450	Outlander MAX Left	15 - 18	911			△	△					
450	Outlander MAX Right/Rear	15 - 18	910			△	△	910			△	△
DS	450	08 - 12	907*			△	△	908			△	△
	500 Outlander Left	13 - 14	911			△	△					
	500 Outlander Right/Rear	13 - 14	910			△	△	910			△	△
	500 Outlander MAX Left	13 - 14	911			△	△					
	500 Outlander MAX Right/Rear	13 - 14	910			△	△	910			△	△
	500 Outlander MAX STD Left/Rear	07 - 12	754			△	△	754			△	△
	500 Outlander MAX STD Right	07 - 12	767			△	△					
	500 Outlander MAX XT Left/Rear	07 - 12	754			△	△	754			△	△
	500 Outlander MAX XT Right	07 - 12	767			△	△					
	500 Outlander STD Left/Rear	07 - 12	754			△	△	754			△	△
	500 Outlander STD Right	07 - 12	767			△	△					
	500 Outlander XT Left/Rear	07 - 12	754			△	△	754			△	△
	500 Outlander XT Right	07 - 12	767			△	△					
	500 Renegade Left/Rear	08 - 11	754			△	△	754			△	△
	500 Renegade Right	08 - 11	767			△	△					
	500 Renegade Left/Rear	12 - 13	911			△	△	911			△	△
	500 Renegade Right/Rear	12 - 13	910			△	△	910			△	△
	500 Renegade Left/Rear	14	911			△	△	911			△	△
	500 Renegade Right/Rear	14	910			△	△	910			△	△
	650 Outlander 6x6 Left/Rear	14 - 18	911			△	△	911			△	△
	650 Outlander 6x6 Right/Rear	14 - 18	910			△	△	910			△	△
	650 Outlander Left	13 - 15	911			△	△					
	650 Outlander Right/Rear	13 - 15	910			△	△	910			△	△
	650 Outlander MAX Left	13 - 15	911			△	△					
	650 Outlander MAX Right/Rear	13 - 15	910			△	△	910			△	△
	650 Outlander MAX STD Left/Rear	07 - 12	754			△	△	754			△	△
	650 Outlander MAX STD Right	07 - 12	767			△	△					
	650 Outlander MAX XT Left/Rear	07 - 12	754			△	△	754			△	△
	650 Outlander MAX XT Right	07 - 12	767			△	△					
	650 Outlander STD Left/Rear	07 - 12	754			△	△	754			△	△
	650 Outlander STD Right	07 - 12	767			△	△					
	650 Outlander XT Left/Rear	07 - 12	754			△	△	754			△	△
	650 Outlander XT Right	07 - 12	767			△	△					
	800 Commander Left/Rear	11 - 14	638			△	△	611			△	△
	800 Commander Right	11 - 14	611			△	△					
	800 Outlander Left	12 - 15	911			△	△					
	800 Outlander Right/Rear	12 - 15	910			△	△	910			△	△
	800 Outlander MAX Left	13 - 14	911			△	△					
	800 Outlander MAX Right/Rear	13 - 14	910			△	△	910			△	△
	800 Outlander MAX LTD Left/Rear	07 - 11	754			△	△	754			△	△
	800 Outlander MAX LTD Right	07 - 11	767			△	△					
	800 Outlander MAX STD Left/Rear	07 - 11	754			△	△	754			△	△
	800 Outlander MAX STD Right	07 - 11	767			△	△					
	800 Outlander MAX XT Left/Rear	07 - 11	754			△	△	754			△	△
	800 Outlander MAX XT Right	07 - 11	767			△	△					
	800 Outlander STD Left/Rear	07 - 11	754			△	△	754			△	△
	800 Outlander STD Right	07 - 11	767			△	△					
	800 Outlander XT Left/Rear	07 - 11	754			△	△	754			△	△
	800 Outlander XT Right	07 - 11	767			△	△					
	800 Renegade EFi Left/Rear	07 - 11	754			△	△	754			△	△
	800 Renegade EFi Right	07 - 11	767			△	△					
	800 Renegade Left/Rear	08 - 11	754			△	△	754			△	△
	800 Renegade Right	08 - 11	767			△	△					
	800 Renegade Left/Rear	12 - 13	911			△	△	911			△	△
	800 Renegade Right/Rear	12 - 13	910			△	△	910			△	△
	800 Renegade Left/Rear	14 - 15	911			△	△	911			△	△
	800 Renegade Right/Rear	14 - 15	910			△	△	910			△	△
	800 Renegade X Left/Rear	08 - 11	754			△	△	754			△	△
	800 Renegade X Right	08 - 11	767			△	△					
	1000 Commander Left/Rear	11 - 14	638			△	△	611			△	△

\* = 2 sets required / 2 jeux pour l'Avant.

△ = Available quality / Qualité disponible.

To select compound for off-road front/rear - see page 23-25 / Pour sélectionner vos plaquettes off-road avant/arrière - voir page 23-25.





			COMPOUND CHOICE				COMPOUND CHOICE			
CAN-AM			HF	ATS	SI	RSI	HF	ATS	SI	RSI
1000 Commander Right	11 - 14	611			△	△				
1000 Commander MAX Left	14 - 18	638			△	△	754		△	△
1000 Commander MAX Right	14 - 18	611			△	△	767		△	△
1000 Maverick Left	13 - 18	638			△	△	754		△	△
1000 Maverick Right	13 - 18	611			△	△	767		△	△
1000 Outlander 6x6 Left/Rear	14 - 18	911			△	△	911		△	△
1000 Outlander 6x6 Right/Rear	14 - 18	910			△	△	910		△	△
1000 Outlander Left	12 - 15	911			△	△				
1000 Outlander Right/Rear	12 - 15	910			△	△	910		△	△
1000 Outlander MAX Left	12 - 18	911			△	△				
1000 Outlander MAX Right/Rear	12 - 18	910			△	△	910		△	△
1000 Renegade Left/Rear	12 - 13	911			△	△	911		△	△
1000 Renegade Right/Rear	12 - 13	910			△	△	910		△	△
1000 Renegade Left/Rear	14 - 18	911			△	△	911		△	△
1000 Renegade Right/Rear	14 - 18	910			△	△	910		△	△
<b>CANNONDALE</b>										
440 Blaze Left/Rear	03	754			△	△	754		△	△
440 Blaze Right	03	767			△	△				
440 Cannibal Left/Rear	03	754			△	△	754		△	△
440 Cannibal Right	03	767			△	△				
440 Glamis Left/Rear	03	754			△	△	754		△	△
440 Glamis Right	03	767			△	△				
440 Moto Left/Rear	03	754			△	△	754		△	△
440 Moto Right	03	767			△	△				
440 Speed Left/Rear	03	754			△	△	754		△	△
440 Speed Right	03	767			△	△				
<b>CECTEK</b>										
500 EFI Gladiator	09 - 13	810*	△		△	△	544	△	△	△
500 EFI King Cobra	09 - 13	878*	△		△	△	544	△	△	△
500 EFI Quadrift	09 - 11	878*	△		△	△	544	△	△	△
500 i Estoc	10	878*	△		△	△	544	△	△	△
<b>CF MOTO</b>										
450 C-Force L	16 - 17	914*			△	△	799		△	△
450 G-Force L	16 - 17	914*			△	△	799		△	△
CF 500 Terralander	13 - 15	914*			△	△	799		△	△
550 C-Force	16 - 17	914*			△	△	799		△	△
550 U-Force Left	15 - 16	638			△	△				
550 U-Force Right	15 - 16	611			△	△				
550 Z-Force Left	15 - 16	638			△	△				
550 Z-Force Right	15 - 16	611			△	△				
CF 625 Terralander	11 - 15	914*			△	△	799		△	△
800 Z-Force EX Left	15	638			△	△				
800 Z-Force EX Right	15	611			△	△				
CF 800 Terralander	12 - 14	914*			△	△	799		△	△
<b>CPI</b>										
250 XS ATV	07 - 08	810*	△		△	△				
XS 250 Quad	06 - 08	544*	△		△	△	848	△	△	
<b>DERBI</b>										
DXR 200 Quad (Front disc)	04 - 07	544*	△		△	△	586	△	△	△
DXR 200 Quad (Front drum)	04 - 05	2028*					586	△	△	△
DXR 200 Quad (Front drum)	04 - 05	2028*					611	△	△	△
DXR 250 Quad (Front disc)	04 - 07	544*	△		△	△	586	△	△	△
DXR 250 Quad (Front drum)	04 - 05	2028*					586	△	△	△
DXR 250 Quad (Front drum)	04 - 05	2028*					611	△	△	△
<b>E-TON</b>										
RXL 150 Viper	07	2012*					847	△	△	△
VXL 250 Vector, ST Vector	06 - 07	544*	△		△	△	847	△	△	△
VTX 300 Vortex, ST Vortex	07	544*	△		△	△	847	△	△	△
VXL 300 Vector, ST Vector	07 - 13	544*	△		△	△	847	△	△	△
<b>GAS GAS</b>										
50 Wild HP	04 - 07	671*	△		△	△	671	△	△	△

Applications  
ATV/UTV

\* = 2 sets required / 2 jeux pour l'Avant.

△ = Available quality / Qualité disponible.

To select compound for off-road front/rear - see page 23-25 / Pour sélectionner vos plaquettes off-road avant/arrière - voir page 23-25.



## COMPOUND CHOICE

## COMPOUND CHOICE



GAS GAS				HF	ATS	SI	RSI		HF	ATS	SI	RSI
200	Wild HP	08 - 09	671*	△		△	△	671	△		△	△
240	Wild HP	04 - 06	671*	△		△	△	671	△		△	△
250	Wild HP	08	671*	△		△	△	671	△		△	△
300	Wild HP	03 - 05	671*	△		△	△	671	△		△	△
450	Wild HP	03 - 09	671*	△		△	△	671	△		△	△
515	Wild HP	09	671*	△		△	△	671	△		△	△
GOES												
360	Max	08 - 14	914*			△	△					
520	Max	07 - 12	914*			△	△	799			△	△
G	520	07 - 12	914*			△	△	799			△	△
G	525	12 - 14	914*			△	△	799			△	△
G	620	11 - 14	914*			△	△	799			△	△
G	625 A	12 - 14	914*			△	△	799			△	△
HISUN												
HS	400 UTV Left/Rear	15 - 17	638			△	△	767			△	△
HS	400 UTV Right	15 - 17	611			△	△					
HS	500 UTV Left/Rear	15 - 17	638			△	△	767			△	△
HS	500 UTV Right	15 - 17	611			△	△					
HS	700 UTV Left (2 cal.rear)	15 - 17	638			△	△	638			△	△
HS	700 UTV Left/Rear	15 - 17	638			△	△	767			△	△
HS	700 UTV Right	15 - 17	611			△	△					
HS	700 UTV Right (2 cal.rear)	15 - 17	611			△	△	611			△	△
HS	800 UTV Left (2 cal.rear)	15 - 17	638			△	△	638			△	△
HS	800 UTV Right (2 cal.rear)	15 - 17	611			△	△	611			△	△
HONDA												
ATC	70 all models	78 - 85						2069				
ATC	70 K1	76 - 77						2012				
TRX	70	86 - 87	2048*					2041				
ATC	80	76 - 78						2019				
ATC	90 K1, K2, K3	73 - 78						2019				
TRX	90	93 - 01	2012*					2019				
ATC	110 all models	79 - 85						2019				
ATC	125 ME, MF, MG, MH	84 - 87	2012					2019				
TRX	125	85 - 88	2012*					2019				
ATC	185 A, S, SB	80 - 83	2012					2019				
ATC	200	81 - 83	2012					2019				
ATC	200 E Big Red	82 - 83	2012					2019				
ATC	200 ES Big Red	84	2012					2019				
ATC	200 M	84 - 85	2012					2019				
ATC	200 S	84 - 86	2012					2019				
ATC	200 X	83 - 85	592	△		△	△	562	△		△	△
ATC	200 X	86 - 87	592	△		△	△	592	△		△	△
TLR	200 Fatcat	86 - 87	2013					2013				
TLR	200 G, H	86 - 87	2013					2057				
TR	200	86 - 87	2013					2013				
TRX	200	84	2044*					2019				
TRX	200	90 - 91	2083*					2019				
TRX	200 D Type II	91 - 97	2083*					2019				
TRX	200 SX	86 - 88	2083*					2019				
ATC	250 ES, SX	85 - 87	2019					2024				
ATC	250 R	81	536	△		△	△	2014				
ATC	250 R	82 - 84	584	△		△	△	562	△		△	△
ATC	250 R	85 - 86	558	△		△	△	558	△		△	△
ATC	250 X	85	558	△		△	△	562	△		△	△
FL	250 Odyssey	77 - 84	525	△				2019				
FL	250 Odyssey	84	529	△				2019				
MT	250 K1	74 - 76	2023					2023				
MTX	250 R	86	558	△		△	△					
TL	250	75 - 76	2013					2013				
TRX	250	85 - 87	2044*					2024				
TRX	250 EX Sportrax	01 - 08	592*	△		△	△	2055				
TRX	250 R	86 - 89	603*	△		△	△	558	△		△	△
TRX	250 R Fourtrax	88	603*	△		△	△	558	△		△	△
TRX	250 Recon	97 - 14	2083*					2055				
TRX	250 X	08 - 13	592*			△	△	2055				

\* = 2 sets required / 2 jeux pour l'Avant.

△ = Available quality / Qualité disponible.

To select compound for off-road front/rear - see page 23-25 / Pour sélectionner vos plaquettes off-road avant/arrière - voir page 23-25.



HONDA				COMPOUND CHOICE				COMPOUND CHOICE					
				HF	ATS	SI	RSI		HF	ATS	SI	RSI	
TRX	250	X Fourtrax	87	603*	△		△	△	558	△		△	△
TRX	250	X Fourtrax	88 - 92	584*	△		△	△	584	△		△	△
TRX	300		88 - 00						2024				
TRX	300	4WD	88 - 00	2085*					2024				
TRX	300	EX	93 - 00	592*	△		△	△	562	△		△	△
TRX	300	EX Sportrax	01 - 08	592*	△		△	△	592	△		△	△
TRX	300	X	09	592*			△	△	592			△	△
ATC	350	Odyssey	85	558	△		△	△	562	△		△	△
ATC	350	X	85	558	△		△	△	562	△		△	△
ATC	350	X	86 - 89	603	△		△	△	562	△		△	△
FL	350	R Odyssey	85 - 87	2044*					610	△			
TRX	350	all models	86 - 89	2045					2046				
TRX	350	Rancher /ES 2x4, 4x4	00 - 09	2085*					2207				
FL	400	R Pilot	89 - 90	2044*					610	△			
TRX	400	AT	04 - 11	2085*					2207				
TRX	400	EX Sportrax	01 - 08	592*	△		△	△	592	△		△	△
TRX	400	Fourtrax EX	99 - 00	592*	△		△	△	592	△		△	△
TRX	400	FW Fourtrax Foreman	95 - 02	2085*					2207				
TRX	400	X	09 - 12	592*			△	△	592			△	△
TRX	420	FA / FPA	09 - 13	592*			△	△	813			△	△
TRX	420	FPE / FPM 4x4	09 - 14	592*			△	△					
TRX	450	EX Sportrax	01 - 05	592*	△		△	△	592	△		△	△
TRX	450	Foreman ES, Foreman S	98 - 04	2085*					2207				
TRX	450	R	04 - 09	694*	△		△	△	813			△	△
TRX	500	all models	05 - 14	829*			△		2046				
TRX	500	Foreman, Rubicon	00 - 09	2085*					2072				
TRX	650	FA Rincon	03 - 05	2085*					813			△	△
TRX	650	FGA Rincon	04 - 05	2085*					813			△	△
TRX	680	FA6 Rincon	06 - 15	829*			△		813			△	△
TRX	680	FGA6 Rincon	06 - 15	829*			△		813			△	△
TRX	700	XX	08 - 12	694*			△	△	829			△	
<b>HYOSUNG</b>													
TE	400		05 - 06	536*	△		△	△	649	△		△	△
TE	450		07 - 11	536*	△		△	△	649	△		△	△
<b>JOHN DEERE</b>													
HPX	350	Gator	10 - 14	908*			△	△	908*			△	△
	500	Buck EX, EXT Left/Rear	05	754			△	△	767			△	△
	500	Buck EX, EXT Right	05	767			△	△					
	500	Buck Left/Rear	05	754			△	△	767			△	△
	500	Buck Right	05	767			△	△					
	500	Trail Buck Left/Rear	05	754			△	△	767			△	△
	500	Trail Buck Right	05	767			△	△					
XUV	625	Gator	11	912*			△	△					
	650	Trail Buck EX, EXT Left/Rear	05	754			△	△	767			△	△
	650	Trail Buck EX, EXT Right	05	767			△	△					
	650	Trail Buck Left/Rear	05	754			△	△	767			△	△
	650	Trail Buck Right	05	767			△	△					
XUV	825	Gator	11	912*			△	△					
XUV	855	D Gator	11	912*			△	△					
<b>KAWASAKI</b>													
KLF	110	Mojave	87 - 88	2015*					2183				
KLT	110		84 - 86	2015					2183				
KLT	160		85	2015					2183				
KLF	185	Bayou	85						2038				
KLF	185	Bayou	86 - 88	2040*					2038				
KLT	185		86 - 87	2015					2183				
KLT	200		81 - 84	2015					2040				
KLF	220	Bayou	88 - 02	2040*					2038				
KLT	250		82 - 83	2015					2040				
KLT	250	Police	84	2015					2040				
KLT	250	Prairie	83 - 85	2015					2040				
KSF	250	Mojave	87 - 02	591*	△		△	△	592	△		△	△
KXF	250	Tecate	87 - 88	591*	△		△	△	592	△		△	△
KXT	250	Tecate	84	2040					544	△			
KXT	250	Tecate	85 - 86	546	△		△	△	586	△		△	△

Applications  
ATV/UTV

\* = 2 sets required / 2 jeux pour l'Avant.  
△ = Available quality / Qualité disponible.





## COMPOUND CHOICE

## COMPOUND CHOICE



KAWASAKI					HF	ATS	SI	RSI		HF	ATS	SI	RSI
KXT	250 Tecate	87 - 88	591		△		△	△	592	△		△	△
KAF	300 Mule 500	92 - 95	2053*										
KAF	300 Mule 550	03 - 05	2053*										
KEF	300 Lakota	95 - 04	591*		△		△	△	592	△		△	△
KLF	300 A1, A2 Bayou	86 - 87	2054*						2038*				
KLF	300 Bayou	88 - 04	546*		△		△	△	2038*				
KLF	300 Bayou Left/Rear	89 - 05	611		△		△	△	2197				
KLF	300 Bayou Right	89 - 05	638		△		△	△					
KVF	300 Brute Force	13 - 17	536*		△		△	△	810			△	△
KVF	300 Prairie	99 - 02	536*		△		△	△					
KVF	300 Prairie 4x4	99 - 05	536*		△		△	△					
KVF	360 Prairie 2x4, 4x4	03 - 08	536*		△		△	△					
KFX	400	02 - 05	592*		△		△	△	649	△		△	△
KLF	400 Bayou Left	93 - 99	611		△		△	△	2197				
KLF	400 Bayou Right	93 - 99	638		△		△	△					
KVF	400 Prairie	97 - 98	536*		△		△	△	2197				
KVF	400 Prairie 2x4	99 - 01	536*		△		△	△					
KVF	400 Prairie 4x4	99 - 02	536*		△		△	△					
KFX	450 Left/Rear	07 - 15	801				△	△	592			△	△
KFX	450 Right	07 - 15	798				△	△					
KVF	650 Brute Force 4x4 Left	05 - 11	801				△	△					
KVF	650 Brute Force 4x4 Right	05 - 11	798				△	△					
KVF	650 Brute Force 4x4i Left	05 - 11	611		△		△	△					
KVF	650 Brute Force 4x4i Right	05 - 11	638		△		△	△					
KVF	650 Prairie Left	01 - 03	801				△	△					
KVF	650 Prairie Right	01 - 03	798				△	△					
KFX	700 V-Force Left	04 - 13	801				△	△					
KFX	700 V-Force Right	04 - 13	798				△	△					
KSV	700 V-Force Left	04 - 11	801				△	△					
KSV	700 V-Force Right	04 - 11	798				△	△					
KVF	700 Prairie Left	04 - 13	801				△	△					
KVF	700 Prairie Right	04 - 13	798				△	△					
KRF	750 Teryx 4x4 Left	08 - 13	611				△	△					
KRF	750 Teryx 4x4 Right	08 - 13	638				△	△					
KVF	750 Brute Force 4x4i Left	05 - 15	611		△		△	△					
KVF	750 Brute Force 4x4i Right	05 - 15	638		△		△	△					
	800 Mule Pro FX Left	15 - 17	611				△	△					
	800 Mule Pro FX Right	15 - 17	638				△	△					
KRF	800 Teryx BEF/CEF/DEF Left	14 - 17	611				△	△					
KRF	800 Teryx BEF/CEF/DEF Right	14 - 17	638				△	△					
KRT	800 Teryx 4 BEF/CEF/DEF Left	14 - 17	611				△	△					
KRT	800 Teryx 4 BEF/CEF/DEF Right	14 - 17	638				△	△					
<b>KTM</b>													
SX	450 ATV	08 - 10	866*				△	△	867			△	△
XC	450 ATV	08 - 10	866*				△	△	867			△	△
SX	505 ATV	08 - 12	866*				△	△	867			△	△
XC	505 ATV	08 - 12	866*				△	△	867			△	△
<b>KYMCO</b>													
	50 MXU	05 - 10	2012*						749	△			
	150 MXU	05 - 17	2012*						749	△			
	250 MXU	06 - 14	810*		△		△	△	775			△	△
	250 Urban Quad	06	810*		△		△	△	775			△	△
KXR	250	04 - 14	810*		△		△	△	775			△	△
	300 Maxxer	06 - 13	810*		△		△	△	775			△	△
	300 Maxxer Supermoto	15	810*		△		△	△	775			△	△
	300 MXU	06 - 17	810*		△		△	△	810*			△	△
	400 Maxxer	08 - 10	822*			△	△	△	822		△	△	△
	400 Maxxer (Parking Brake)	08 - 10							921	△			
	400 MXU	08 - 11	822*			△	△	△	822		△	△	△
	400 MXU (Parking Brake)	08 - 11							921	△			
	450 i Maxxer	10 - 14	822*			△	△	△	822		△	△	△
	450 i Maxxer (Parking Brake)	10 - 14							921	△			
	450 i MXU	11 - 14	822*		△	△	△	△	822		△	△	△
	450 i MXU (Parking Brake)	11 - 14							921	△			
	500 MXU	06 - 08	810*		△		△	△	810*			△	△
	500 MXU	09 - 14	945*				△	△					

\* = 2 sets required / 2 jeux pour l'Avant.

△ = Available quality / Qualité disponible.

To select compound for off-road front/rear - see page 23-25 / Pour sélectionner vos plaquettes off-road avant/arrière - voir page 23-25.





## COMPOUND CHOICE

## COMPOUND CHOICE



POLARIS				HF	ATS	SI	RSI		HF	ATS	SI	RSI
400 Scrambler 2x4, 4x4	00 - 03	716*	△	△	△	△	755		△	△	△	△
400 Scrambler 4x4	98	716*	△	△	△	△	717	△	△	△	△	△
400 Scrambler 4x4	99 - 03	716*	△	△	△	△	755		△	△	△	△
400 Scrambler L 4x4	95 - 97	716*	△	△	△	△	717	△	△	△	△	△
400 Sport	99 - 00	716*	△	△	△	△	755		△	△	△	△
400 Sport L	94 - 98	716*	△	△	△	△	717	△	△	△	△	△
400 Sportsman	01 - 13	716*	△	△	△	△	755		△	△	△	△
400 Sportsman L 4x4	94 - 97	716*	△	△	△	△	717	△	△	△	△	△
400 Trail Blazer	03 - 04	716*	△	△	△	△	755		△	△	△	△
400 Xplorer L 4x4	95 - 99	716*	△	△	△	△	717	△	△	△	△	△
400 Xplorer L 4x4	00 - 02	716*	△	△	△	△	755		△	△	△	△
400 Xpress L	96 - 97	716*	△	△	△	△	717	△	△	△	△	△
425 2x4, 4x4 Magnum	95 - 98	716*	△	△	△	△	717	△	△	△	△	△
425 Magnum 6x6	96	716*	△	△	△	△	717		△	△	△	△
425 Magnum 6x6 Middle Axle Brake	96	756		△	△	△						
425 Xpedition 4x4	00 - 03	716*	△	△	△	△	755		△	△	△	△
450 Outlaw MXR	09 - 11	898*		△	△	△	642		△	△	△	△
450 Outlaw S	08	898*		△	△	△	642		△	△	△	△
450 Sportsman	06 - 09	716*	△	△	△	△	787		△	△	△	△
455 Diesel EBS 4x4	99 - 01	716*	△	△	△	△	755		△	△	△	△
500 ATP HO	04 - 05	716*	△	△	△	△	716*		△	△	△	△
500 Big Boss 6x6	98 - 99	716*	△	△	△	△	717	△	△	△	△	△
500 Big Boss 6x6 Middle Axle Brake	98 - 99	717		△	△	△						
500 E Scrambler 2x4, 4x4	08 - 11	642*	△	△	△	△	787		△	△	△	△
500 Magnum 2x4, 4x4	02 - 07	716*	△	△	△	△	787		△	△	△	△
500 Magnum 4x4	00 - 01	716*	△	△	△	△	755		△	△	△	△
500 Outlaw	06 - 09	716*	△	△	△	△	716		△	△	△	△
500 Predator	03 - 13	716*	△	△	△	△	716		△	△	△	△
500 Predator e	06 - 13	716*	△	△	△	△	787		△	△	△	△
500 Ranger 2x4	08 - 07	897*		△	△	△	800		△	△	△	△
500 Ranger 2x4 EFi	08 - 13	897*		△	△	△	800		△	△	△	△
500 Ranger 2x4, 4x4, 6x6	02 - 13	800*		△	△	△	800*		△	△	△	△
500 Ranger 4x4	12 - 13	897*		△	△	△	800		△	△	△	△
500 Ranger 6x6	00 - 02	716*	△	△	△	△						
500 Ranger XP	06 - 09	800*		△	△	△	800		△	△	△	△
500 Revolver	06	642*	△	△	△	△	642		△	△	△	△
500 Scrambler 2x4	01 - 02	716*	△	△	△	△	755		△	△	△	△
500 Scrambler 4x4	97	716*	△	△	△	△	717	△	△	△	△	△
500 Scrambler 4x4	98 - 13	716*	△	△	△	△	755		△	△	△	△
500 Sportsman 4x4	96 - 14	716*	△	△	△	△	717	△	△	△	△	△
500 Sportsman 6x6	00 - 11	716*	△	△	△	△	757		△	△	△	△
500 Sportsman EBS 4x4	98 - 02	716*	△	△	△	△	755		△	△	△	△
500 Sportsman HO (from 16.12.2008)	09 - 14	642*		△	△	△	899		△	△	△	△
500 Sportsman HO (to 15.12.2008)	03 - 08	642*		△	△	△	787		△	△	△	△
500 Xplorer 4x4	97	716*	△	△	△	△	717	△	△	△	△	△
525 Outlaw	07 - 13	898*		△	△	△	642		△	△	△	△
525 Outlaw IRS	08 - 13	898*		△	△	△	642		△	△	△	△
525 Outlaw S	08 - 11	898*		△	△	△	642		△	△	△	△
550 Sportsman	11 - 14	899*		△	△	△	899		△	△	△	△
550 Sportsman EPS	10 - 14	899*		△	△	△	899		△	△	△	△
550 Sportsman EPS X2	14	899*		△	△	△	899		△	△	△	△
550 Sportsman Touring EPS	10 - 12	899*		△	△	△	899		△	△	△	△
550 Sportsman X2	10 - 14	899*		△	△	△	899		△	△	△	△
550 Sportsman XP	09 - 12	899*		△	△	△	899		△	△	△	△
550 Sportsman XP EPS	09 - 14	899*		△	△	△	899		△	△	△	△
550 Sportsman XP Touring EPS	12 - 14	899*		△	△	△	899		△	△	△	△
570 Ranger RZR EFi	12 - 13	898*		△	△	△	642		△	△	△	△
600 Sportsman	03 - 06	642*		△	△	△	787*		△	△	△	△
700 MVRS 4x4	08	897*		△	△	△	897		△	△	△	△
700 Ranger 4x4 EFi	08	897*		△	△	△	800		△	△	△	△
700 Ranger 6x6 EFi	12 - 13	897*		△	△	△	800		△	△	△	△
700 Sportsman	02 - 09	642*		△	△	△	787*		△	△	△	△
700 Sportsman MV 700	05 - 06	642*		△	△	△	787		△	△	△	△
800 MVRS 4x4	08	897*		△	△	△	897		△	△	△	△
800 Ranger 4x4 EFi	10	897*		△	△	△	897		△	△	△	△
800 Ranger 6x6 EFi	12 - 15	897*		△	△	△	897		△	△	△	△
800 Ranger Crew	12 - 15	897*		△	△	△	897		△	△	△	△
800 Ranger RZR EFi	08 - 14	898*		△	△	△	642		△	△	△	△

\* = 2 sets required / 2 jeux pour l'Avant.

△ = Available quality / Qualité disponible.

To select compound for off-road front/rear - see page 23-25 / Pour sélectionner vos plaquettes off-road avant/arrière - voir page 23-25.





POLARIS			COMPOUND CHOICE				COMPOUND CHOICE				
			HF	ATS	SI	RSI		HF	ATS	SI	RSI
800 Ranger RZR S EFi	09 - 15	898*		△	△	△	642		△	△	△
800 Ranger RZR4 EFi	12 - 14	897*		△	△	△	800		△	△	△
800 Ranger XP	12 - 13	897*		△	△	△	800		△	△	△
800 RZR	08 - 15	898*		△	△	△	642		△	△	△
800 RZR-4	10 - 14	897*		△	△	△	800		△	△	△
800 Sportsman (from 16.12.2008)	09 - 14	642*		△	△	△	899		△	△	△
800 Sportsman (to 15.12.2008)	05 - 08	642*		△	△	△	787		△	△	△
850 Forest	15	899*		△	△	△	899		△	△	△
850 Scrambler	15	899*		△	△	△	899		△	△	△
850 Scrambler HO EPS	13 - 15	899*		△	△	△	899		△	△	△
850 Scrambler MD	15	899*		△	△	△	899		△	△	△
850 Scrambler XP HO EPS	14 - 15	899*		△	△	△	899		△	△	△
850 Sportsman	11 - 13	899*		△	△	△	899		△	△	△
850 Sportsman MV	12	899*		△	△	△	899		△	△	△
850 Sportsman Touring	14 - 15	899*		△	△	△	899		△	△	△
850 Sportsman Touring EPS	10 - 13	899*		△	△	△	899		△	△	△
850 Sportsman Touring HO EPS	13 - 14	899*		△	△	△	899		△	△	△
850 Sportsman Touring MD	15	899*		△	△	△	899		△	△	△
850 Sportsman X2	11	899*		△	△	△	899		△	△	△
850 Sportsman XP	09 - 14	899*		△	△	△	899		△	△	△
850 Sportsman XP EPS	09 - 14	899*		△	△	△	899		△	△	△
850 Sportsman XP HO EPS	13 - 14	899*		△	△	△	899		△	△	△
850 Sportsman XP HO EPS MD	15	899*		△	△	△	899		△	△	△
850 Sportsman XP Touring EPS	15	899*		△	△	△	899		△	△	△
900 Ranger 4x4 Diesel	10 - 14	897*		△	△	△	897		△	△	△
900 Ranger RZR4 XP EFi	12 - 15	897*		△	△	△	897		△	△	△
900 Ranger RZR4 XP4 EFi	12 - 14	897*		△	△	△	897		△	△	△
1000 Forest	15	899*		△	△	△	899		△	△	△
1000 General EPS	16 - 18	897*		△	△	△	898		△	△	△
1000 Ranger RZR XP	14	897*		△	△	△	897		△	△	△
1000 Scrambler MD	15 - 18	899*		△	△	△	899		△	△	△
1000 Scrambler XP	15 - 18	899*		△	△	△	899		△	△	△
1000 Scrambler XP HO EPS	14	899*		△	△	△	899		△	△	△
1000 Sportsman MD	15 - 18	899*		△	△	△	899		△	△	△
1000 Sportsman Touring	15 - 18	899*		△	△	△	899		△	△	△
1000 Sportsman XP	15 - 18	899*		△	△	△	899		△	△	△
1050 MV Diesel Crew	13 - 18	897*		△	△	△	897		△	△	△
<b>SUZUKI</b>											
ALT 50	83 - 84						2020				
LT 50	84 - 02						2020				
LT-A 50 Quadmaster	01 - 05	2101					2017				
LT-Z 50 QuadSport	06 - 17	2101*					2017				
LT 80	87 - 06	2101*					2104				
LT-Z 90 QuadSport	07 - 14	2017*					2104				
ALT 125	84 - 86						2016				
ALT 125 D	83						2107				
LT 125 D	83						2107				
LT 125 E-H	84 - 87						2016				
LT 160	89 - 92	2181*					2016				
LT-F 160	91 - 04	2181*					2016				
ALT 185	85 - 87						2016				
LT 185	84 - 87						2016				
LT 230	85 - 86	2051*					2016				
LT 230	85 - 88	591*	△		△	△	584	△		△	△
LT 230	86 - 93	591*	△		△	△	592	△		△	△
LT-F 230	86 - 87	2051*					2016				
LT 250	85 - 86	2051*					2098				
LT 250	85 - 87	591*	△		△	△	584	△		△	△
LT 250	88 - 94	591*	△		△	△	649	△		△	△
LT 250	89 - 90	591*	△		△	△	592	△		△	△
LT 250 4WD	87 - 98	2053*					2110				
LT-F 250	88 - 01	2053*					2110				
LT-F 250 4WD V, W Quadrunner	97 - 98	2053*					2098				
LT-F 250 Ozark	03 - 13	536*	△		△	△					
LT-Z 250 Quad Sport	04 - 11	536*	△		△	△					
LT-F 280 4WD	91 - 98						2052				
LT 300	87 - 89	2051*					2098				

Applications  
ATV/UTV

\* = 2 sets required / 2 jeux pour l'Avant.

△ = Available quality / Qualité disponible.

To select compound for off-road front/rear - see page 23-25 / Pour sélectionner vos plaquettes off-road avant/arrière - voir page 23-25.



## COMPOUND CHOICE

## COMPOUND CHOICE



SUZUKI				HF	ATS	SI	RSI		HF	ATS	SI	RSI
LT-F	300	88 - 90	2051					2052				
LT-F	300 King Quad	91 - 01						2052				
LT-F	300 King Quad Left/Rear	02	611	△		△	△	2052				
LT-F	300 King Quad Right	02	638	△		△	△					
KLT-A	400 King Quad Left	08 - 14	835			△	△					
KLT-A	400 King Quad Right	08 - 14	836			△	△					
KLT-F	400 King Quad Left	08 - 14	835			△	△					
KLT-F	400 King Quad Right	08 - 14	836			△	△					
LT-A	400 Eiger 2WD/4WD	02 - 07	536*	△		△	△	2018				
LT-A	400 King Quad Left	08 - 14	835			△	△					
LT-A	400 King Quad Right	08 - 14	836			△	△					
LT-F	400 Eiger 2WD/4WD	02 - 07	536*	△		△	△	2018				
LT-F	400 King Quad Left	08 - 14	835			△	△					
LT-F	400 King Quad Right	08 - 14	836			△	△					
LT-Z	400 Quad Sport	02 - 15	592*	△		△	△	649	△		△	△
LT-A	450 King Quad Left	08 - 14	835			△	△					
LT-A	450 King Quad Right	08 - 14	836			△	△					
LT-R	450 Left/Rear	06 - 12	611	△		△	△	649	△		△	△
LT-R	450 Right	06 - 12	638	△		△	△					
LT	500	87 - 95	591*	△		△	△	649	△		△	△
LT-A	500 F Vinson	02	536*	△		△	△					
LT-A	500 FY Quadmaster Left	00 - 08	611	△		△	△					
LT-A	500 FY Quadmaster Right	00 - 08	638	△		△	△					
LT-A	500 King Quad Left	11 - 14	835			△	△					
LT-A	500 King Quad Right	11 - 14	836			△	△					
LT-F	500 F Left	98 - 07	638	△		△	△					
LT-F	500 F Right	98 - 07	611	△		△	△					
LT-A	700 King Quad Left	05 - 11	835			△	△					
LT-A	700 King Quad Right	05 - 11	836			△	△					
LT-V	700 Quadrunner Twin Peaks Left	04 - 06	801			△	△					
LT-V	700 Quadrunner Twin Peaks Right	04 - 06	798			△	△					
LT-A	750 King Quad Left	08 - 14	835			△	△					
LT-A	750 King Quad Right	08 - 14	836			△	△					
<b>SYM</b>												
	200 Quadlander	12 - 13	810*	△		△	△	847	△		△	△
	200 Trackrunner	05 - 08	810*	△		△	△	847	△		△	△
	250 Quadlander	06 - 07	810*	△		△	△	847	△		△	△
	300 City Max	06 - 07	810*	△		△	△	847	△		△	△
	300 Quadlander	06 - 13	810*	△		△	△	810			△	△
	600 Quad Raider	08 - 15	810*	△		△	△	810			△	△
<b>TGB</b>												
	50 Buffalo	03						688	△			
<b>YAMAHA</b>												
YFM	50 Raptor	04 - 11	2028*					2034				
YF	60 S Moto 4	86						2050				
YT	60 Tri Zinger	84 - 85						2050				
YFM	80	87 - 88	2050*					2034				
YFM	80	92 - 94	2028*					2034				
YFM	80 Badger	95 - 07	2028*					2034				
YFM	80 Grizzly	05 - 08	2028*					2034				
YFM	80 N, S Moto 4	85 - 86						2034				
YFM	80 Raptor	02 - 08	2028*					2034				
YFM	90 RY Raptor	09 - 15	2028*					586	△		△	△
YFM	100 Champ	87 - 88	2050*					2034				
YFM	100 Champ	89 - 91	2028*					2034				
YFA	125 1 D, E Breeze	92 - 93	2028*					2034				
YFA	125 1 F Breeze	94	2028*					2034				
YFA	125 1 G-M Breeze	95 - 07	2028*					2034				
YFA	125 1 W, A, B Breeze	89 - 91	2028*					2034				
YFM	125 Grizzly	04 - 13	2028*					2034				
YT	125 Tri Moto	80 - 81						617	△			
YT	125 Tri Moto	82 - 85						576	△			
YT	175 Tri Moto	82 - 83	2028					576	△			
YFM	200 DXS-DXW Moto 4	86 - 87	2028*					576	△			
YFM	200 N Moto 4	85 - 89	2028*					576	△			

\* = 2 sets required / 2 jeux pour l'Avant.

△ = Available quality / Qualité disponible.

To select compound for off-road front/rear - see page 23-25 / Pour sélectionner vos plaquettes off-road avant/arrière - voir page 23-25.



## COMPOUND CHOICE

## COMPOUND CHOICE



YAMAHA				HF	ATS	SI	RSI		HF	ATS	SI	RSI
YFS	200 R Blaster	03 - 06	536*	△		△	△	592	△		△	△
YFS	200 U-P Blaster	88 - 02	2028					637	△		△	△
YTM	200 EK, EL Tri Moto	83 - 84	2028					576	△			
YTM	200 ERN Tri Moto	85	2028					576	△			
YTM	200 K-N Tri Moto	83 - 85	2028					576	△			
YFM	225 Moto 4	86 - 88	2028*					576	△			
YTM	225 DRN, DRS Tri Moto	85 - 86	2028					576	△			
YTM	225 DXK, DXN Tri Moto	83 - 85	2028					576	△			
YFB	250 Timberwolf	92 - 94	2028*					2035				
YFB	250 Timberwolf	95 - 96	2035*					2035				
YFB	250 Timberwolf 4WD	94 - 03	2035*					2035				
YFM	250	89 - 91	2035*					576	△		△	
YFM	250 AN Bruin 2x4	05 - 07	536*	△		△	△					
YFM	250 Bear Tracker	01 - 04	536*	△		△	△					
YFM	250 Raptor Left/Rear	09 - 14	850			△	△	592	△		△	△
YFM	250 Raptor Right	09 - 14	849			△	△					
YFM	250 Timberwolf (YFB 250 G)	95	2035*					2035				
YFU1TW	250 Pro Hauler	89	2035*					2177				
YFU1W	250 Pro Hauler	89 - 90	2035*					2177				
YTZ	250 Tri Moto	85 - 86	575	△		△	△	575	△		△	△
YFM	300 Warrior	89	536	△		△	△	584	△		△	△
YFM	350 Big Bear Special Edition	99	2178*					2066				
YFM	350 Bruin 2x4, 4x4	04 - 07	536*	△		△	△					
YFM	350 ERT, ERU	87 - 88	2028*					576	△			
YFM	350 ERW, ERA-G	89 - 95	2035*					576	△			
YFM	350 FWB L, LC Big Bear	99	536*	△		△	△	2066				
YFM	350 FWH, FWJ, FWK Big Bear	96 - 98	2178*					2066				
YFM	350 FWT, FWU Big Bear	87 - 88	2114*					576	△			
YFM	350 FWW, FWA-G Big Bear	89 - 95	2178*					576	△			
YFM	350 FXG-FXM Wolverine	95 - 11	536*	△		△	△	592	△		△	△
YFM	350 R Raptor	04 - 14	592*	△		△	△	592	△		△	△
YFM	350 UH, UJ, UK	96 - 98	2178*					2066				
YFM	350 XG,XH Warrior	95 - 96	536*	△		△	△	592	△		△	△
YFM	350 XT, XU Warrior	87 - 88	575*	△		△	△	592	△		△	△
YFM	350 XW, XA-M Warrior	89 - 07	536*	△		△	△	536	△		△	△
YFP	350 U Terrapro	88	2035*					2177				
YFZ	350 Banshee	87 - 89	575*	△		△	△	592	△		△	△
YFZ	350 Banshee	90 - 06	536*	△		△	△	592	△		△	△
YFM	400 FAM Kodiak	00 - 02	536*	△		△	△	754	△		△	△
YFM	400 FAR Kodiak Automatic	03	536*	△		△	△	2066				
YFM	400 FWN Big Bear 4WD	00 - 11	536*	△		△	△	754	△		△	△
YFM	400 FWNH Big Bear-Buckmaster 4WD	00 - 11	536*	△		△	△	754	△		△	△
YFM	400 Kodiak	93 - 99	2178*					2066				
YFM	400 N Big Bear 2WD	00 - 11	536*	△		△	△	754	△		△	△
YFM	450 FA_ Kodiak	03 - 07	536*	△		△	△	754	△		△	△
YFM	450 Wolverine	06 - 10	536*	△		△	△	754	△		△	△
YFZ	450 S Left/Rear	04 - 05	638	△		△	△	592	△		△	△
YFZ	450 S Right	04 - 05	611	△		△	△					
YFZ	450 S Left/Rear	06 - 09	638	△		△	△	709	△		△	△
YFZ	450 S Right	06 - 09	611	△		△	△					
YXR	450 Rhino Left/Rear	06 - 09	611			△	△	816			△	△
YXR	450 Rhino Right	06 - 09	638			△	△					
YFM	550 FGPW Grizzly Left	09 - 16	850			△	△	852			△	△
YFM	550 FGPW Grizzly Right	09 - 16	849			△	△	851			△	△
YFM	600 4x4 Grizzly	98 - 01	592*	△		△	△	2066				
	660 Rhino Left/Rear	05 - 08	611			△	△	816			△	△
	660 Rhino Right	05 - 08	638			△	△					
YFM	660 FWAP 4x4 Grizzly	02 - 08	592*	△		△	△	799			△	△
YFM	660 RN Raptor	01 - 09	592*	△		△	△	592	△		△	△
YFM	700 FGPW Grizzly Left	07 - 17	850			△	△	852			△	△
YFM	700 FGPW Grizzly Right	07 - 17	849			△	△	851			△	△
YFM	700 R Raptor Left/Rear	06 - 08	611			△	△	816			△	△
YFM	700 R Raptor Right	06 - 08	638			△	△					
YFM	700 Raptor	09 - 12	611			△	△	816			△	△
YFM	700 Raptor	09 - 12	638			△	△					
YFM	700 Raptor	13 - 14	611			△	△	709	△		△	△
YFM	700 Raptor	13 - 14	638			△	△					
YXR	700 Rhino Left	08 - 14	638			△	△	638			△	△

Applications  
ATV/UTV

\* = 2 sets required / 2 jeux pour l'Avant.

△ = Available quality / Qualité disponible.

To select compound for off-road front/rear - see page 23-25 / Pour sélectionner vos plaquettes off-road avant/arrière - voir page 23-25.





# ROAD RACING





## COMPOUND CHOICE

## COMPOUND CHOICE



APRILIA				DS	DC	RS		RQ	LS	
RS	250		97 - 02	706*	△	△	△	519	△	△
RS	250 Pista		04	706*	△	△	△	519	△	△
RSV	1000 Factory Pista		04	762*	△	△	△	730	△	△
RSV	1000 Mille		97 - 01	706*	△	△	△	730	△	△
RSV	1000 Mille		02 - 03	762*	△	△	△	730	△	△
RSV	1000 Mille Nera		04	762*	△	△	△	730	△	△
RSV	1000 Mille R		00	706*	△	△	△	730	△	△
RSV	1000 Mille R		01 - 02	762*	△	△	△	730	△	△
RSV	1000 Mille R		04	762*	△	△	△	730	△	△
RSV	1000 Mille R		03	762*	△	△	△	730	△	△
RSV	1000 Mille R		05 - 07	762*	△	△	△	730	△	△
RSV	1000 Mille R Factory		04 - 05	762*	△	△	△	730	△	△
RSV	1000 Mille SP		00	706*	△	△	△	730	△	△
RSV4	1000 , ABS		09 - 13	841*	△	△	△	730	△	△
RSV4-R	1000 , ABS APRC		10	841*	△	△	△	730	△	△
RSV4-RF	1000		15 - 18	901*	△	△	△	730	△	△
RSV4-RR	1000		15 - 18	901*	△	△	△	730	△	△
<b>BENELLI</b>										
	900 Tornado TRE RS		04 - 06	762*	△	△	△	730	△	△
<b>BIMOTA</b>										
BB3	1000		14 - 18	901*	△	△	△	730	△	△
DB5	1000 Mille		05 - 11	762*	△	△	△	730	△	△
DB5	1000 S		07 - 11	762*	△	△	△	730	△	△
SB8	1000 R		98 - 00	706*	△	△	△	519	△	△
SB8K	1000		06	706*	△	△	△	519	△	△
SB8K	1000 Santamonica		07 - 09	762*	△	△	△	519	△	△
YB11	1000		97 - 00	566*		△	△	519	△	△
DB7	1098		08	762*	△	△	△	730	△	△
DB7	1099		09	901*	△	△	△	519	△	△
3D	1100 Tesi		07 - 11	762*	△	△	△	730	△	△
SB6	1100		97 - 00	566*		△	△	519	△	△
DB8	1198		10 - 14	901*	△	△	△	730	△	△
<b>BMW</b>										
S	1000 RR		09 - 18	870*	△	△	△	675	△	△
S	1000 RR HP4		12 - 14	901*	△	△	△	675	△	△
R	1100 S With Integral ABS		01 - 05	778*			△	742	△	△
R	1100 S Without Integral ABS		01 - 05	796*			△	742	△	△
	1200 HP2 Sport		08 - 10	901*	△	△	△	671	△	△
K	1200 R		05 - 08	778*			△	742	△	△
K	1300 R		09 - 15	778*			△	742	△	△
K	1300 R Dynamic		11 - 15	778*			△	742	△	△
<b>DUCATI</b>										
	748 R		00	706*	△	△	△	519	△	△
	748 R		01 - 02	762*	△	△	△	519	△	△
	748 SP		95 - 97	566*		△	△	519	△	△
	748 SPS		98 - 99	706*	△	△	△	519	△	△
	749 , S		03 - 07	762*	△	△	△	730	△	△
	749 R		04 - 07	762*	△	△	△	730	△	△
	848		08 - 10	706*	△	△	△	730	△	△
	848 EVO		11 - 12	841*	△	△	△	730	△	△
	899 Panigale		14 - 15	900*	△	△	△	730	△	△
	900 SS Supersport		95 - 97	566*		△	△	519	△	△
	916 Biposto		94	566*		△	△	519	△	△
	916 SPS		97 - 98	706*	△	△	△	519	△	△
	959 Panigale		16 - 18	900*	△	△	△	730	△	△
	959 Panigale Corse		18 -	900*	△	△	△	730	△	△
D16RR	990 Desmosedici RR		07 - 08	841*	△	△	△	730	△	△
	996 , SPS		99 - 01	706*	△	△	△	519	△	△
	996 R		01	762*	△	△	△	519	△	△
	998 , S		02	706*	△	△	△	519	△	△
	998 R		02	762*	△	△	△	519	△	△
	999 , S		03 - 07	762*	△	△	△	730	△	△
	999 R		03 - 07	762*	△	△	△	730	△	△
	1098		07 - 08	841*	△	△	△	730	△	△

\* = 2 sets required / 2 jeux pour l'Avant.

△ = Available quality / Qualité disponible.

To select compound for racing front/rear - see page 19-22 / Pour sélectionner vos plaquettes racing avant/arrière - voir page 19-22.





COMPOUND CHOICE



COMPOUND CHOICE



DUCATI				DS	DC	RS		RQ	LS
1098 R		08 - 10	841*	△	△	△	730	△	△
1098 R Bayliss LE		09 - 10	841*	△	△	△	730	△	△
1098 S		07 - 08	841*	△	△	△	730	△	△
1100 Panigale V4		18 -	841*	△	△	△	730	△	△
1100 Panigale V4 S		18 -	841*	△	△	△	730	△	△
1100 Panigale V4 Speciale		18 -	841*	△	△	△	730	△	△
1198		09 - 13	841*	△	△	△	730	△	△
1198 S		09 - 12	841*	△	△	△	730	△	△
1198 SP		11 - 12	841*	△	△	△	730	△	△
1199 Panigale		12 - 14	841*	△	△	△	730	△	△
1199 Panigale R		13 - 15	841*	△	△	△	730	△	△
1199 Panigale S		12 - 14	841*	△	△	△	730	△	△
1199 Superleggera		14	841*	△	△	△	730	△	△
1299 Panigale		15 - 17	841*	△	△	△	730	△	△
1299 Panigale R		15 - 17	841*	△	△	△	730	△	△
1299 Panigale R Final Edition		17 - 18	841*	△	△	△	730	△	△
1299 Panigale S		15 - 17	841*	△	△	△	730	△	△
1299 Panigale S Anniversario		17	841*	△	△	△	730	△	△
1299 Superleggera		17	841*	△	△	△	730	△	△
<b>EBR</b>									
1190 RS		12 - 15	856	△		△	857		△
<b>HARLEY DAVIDSON</b>									
XR 1200		08 - 10	860*	△		△	808		△
<b>HONDA</b>									
NSF 100		06	688			△	604	△	
RS 125		95 - 03	566		△	△	618	△	
CBR 250 R (Nissin cal)		11 - 13	627		△	△	881		△
RS 250 R		91 - 92	622*		△	△	614	△	△
RS 250 R		93	566*		△	△	618	△	△
RVF 400 RR (NC35)		90 - 96	622*		△	△	623	△	△
CBR 500 R		13 - 18	700	△	△	△	881	△	△
CB 600 Hornet		07 - 12	627*		△	△	834	△	△
CBR 600 F3		95 - 98	627*		△	△	657	△	△
CBR 600 F4, F4 Sport		99 - 06	734*		△	△	657	△	△
CBR 600 RR		03 - 04	734*		△	△	657	△	△
CBR 600 RR		05 - 06	809*	△	△	△	657	△	△
CBR 600 RR		07 - 08	809*	△	△	△	834	△	△
CBR 600 RR ABS		09 - 18	809*	△	△	△	834	△	△
CBR 650 F		14 - 18	700*	△	△	△	881	△	△
CBR 650 F ABS		14 - 18	700*	△	△	△	881	△	△
CBR 900 RR		98 - 99	734*		△	△	657	△	△
CBR 900 RR Fireblade		92 - 97	622*		△	△	657	△	△
919		02	622*		△	△	657	△	△
CBR 929 RR		00 - 01	734*		△	△	657	△	△
CBR 954 RR		02 - 03	734*		△	△	657	△	△
CBR 1000 RR Fireblade		04 - 05	809*	△	△	△	657	△	△
CBR 1000 RR Fireblade		06 - 08	809*	△	△	△	834	△	△
CBR 1000 RR Fireblade ABS		09 - 16	809*	△	△	△	834	△	△
CBR 1000 RR Fireblade		17 - 18	947*		△	△	834	△	△
CBR 1000 RR SP		14 - 18	901*	△	△	△	834	△	△
CBR 1000 RR SP2		17 - 18	901*	△	△	△	834	△	△
RC213V-S 1000		16 - 18	901*	△	△	△	730	△	△
RVT 1000 RC51		00 - 06	734*		△	△	657	△	△
VTR 1000 SP-1, SP-2		00 - 06	734*		△	△	657	△	△
VTR 1000 Super Hawk		97 - 07	622*		△	△	657	△	△
<b>KAWASAKI</b>									
EX 250 R Ninja		08 - 12	638	△	△	△	638	△	△
EX 300 R Ninja, ABS		13 - 17	638	△	△	△	638	△	△
Z 400 Ninja		18 -	638*	△	△	△	638	△	△
Z 400 Ninja KRT		18 -	638*	△	△	△	638	△	△
ZX-6R 600 (Ninja ZX6)		93 - 97	631*		△	△	687	△	△
ZX-6R 600 (Ninja ZX6R)		95 - 97	631*		△	△	687	△	△
ZX-6R 600 Ninja		98 - 01	686*		△	△	687	△	△
ZX-6R 600 Ninja		07 - 12	838*	△	△	△	687	△	△

Applications  
Racing

\* = 2 sets required / 2 jeux pour l'Avant.

△ = Available quality / Qualité disponible.

To select compound for racing front/rear - see page 19-22 / Pour sélectionner vos plaquettes racing avant/arrière - voir page 19-22.



## COMPOUND CHOICE



## COMPOUND CHOICE



KAWASAKI				DS	DC	RS		RQ	LS	
ZX-6RR	600	Ninja	03 - 06	788*	△	△	△	687	△	△
ZX-6R	636	Ninja	02	686*		△	△	687	△	△
ZX-6R	636	Ninja	03 - 06	788*	△	△	△	687	△	△
ZX-6R	636	Ninja	13 - 18	894*		△	△	834	△	△
ZX-6R	636	Ninja ABS	13 - 18	894*		△	△	834	△	△
ZX-6R	636	Ninja KRT ABS	13 - 18	894*		△	△	834	△	△
ZX-7R	750	Ninja	96 - 03	686*		△	△	556	△	△
ZX-7RR	750	Ninja	96 - 02	676*		△	△	715	△	△
ZX-9R	900	Ninja	96 - 01	686*		△	△	687	△	△
ZX-9R	900	Ninja	02 - 03	782*		△	△	687	△	△
Z	1000		03 - 06	782*		△	△	687	△	△
Z	1000		07 - 09	838*		△	△	657	△	△
ZX	1000	H2 Carbon Ninja	17 - 18	841*	△	△	△	730	△	△
ZX	1000	H2 Ninja	15 - 18	841*	△	△	△	730	△	△
ZX	1000	H2R Ninja	15 - 18	841*	△	△	△	730	△	△
ZX-10R	1000	Ninja	04 - 07	788*	△	△	△	687	△	△
ZX-10R	1000	Ninja	08 - 10	806*	△	△	△	687	△	△
ZX-10R	1000	Ninja	11 - 15	806*	△	△	△	834	△	△
ZX-10R	1000	Ninja	16 - 18	841*	△	△	△	834	△	△
ZX-10R	1000	Ninja ABS	12 - 15	806*	△	△	△	834	△	△
ZX-10R	1000	Ninja KRT	16 - 18	841*	△	△	△	834	△	△
ZX-10R	1000	Ninja SE	18 -	841*	△	△	△	834	△	△
ZX-10RR	1000	Ninja	17 - 18	841*	△	△	△	834	△	△
ZX-12R	1200	Ninja	00 - 03	686*		△	△	556	△	△
ZX-12R	1200	Ninja	04 - 06	788*		△	△	556	△	△
<b>KTM</b>										
RC	250		14 - 15	877		△	△	675	△	△
RC	390		14 - 18	877		△	△	675	△	△
	690	Duke R	14 - 17	841*	△	△	△	675	△	△
RC8	1190		08 - 11	841*	△	△	△	730	△	△
RC8	1190	R	09 - 15	841*	△	△	△	730	△	△
RC8	1190	R Track	11 - 15	841*	△	△	△	730	△	△
<b>MORIWAKI</b>										
MD	250		09	782		△	△	618	△	
<b>MOTO-GUZZI</b>										
	1200	MGS-01 Corsa	05 - 13	762*	△	△	△	730	△	△
<b>MV AGUSTA</b>										
	675	F3	11 - 12	706*	△	△	△	763	△	△
	675	F3	13 - 14	706*	△	△	△	730	△	△
	675	F3	15 - 17	901*	△	△	△	730	△	△
	675	F3 RC	16 - 17	901*	△	△	△	730	△	△
	750	F4 SPR	01 - 03	676*		△	△	763	△	△
	750	F4/F4S	99 - 02	676*		△	△	763	△	△
	800	F3	14 - 17	901*	△	△	△	763	△	△
	800	F3 RC	16 - 17	901*	△	△	△	730	△	△
	1000	F4 LH44	18 -	841*	△	△	△	763	△	△
	1000	F4 R	06 - 07	762*	△	△	△	763	△	△
	1000	F4 R	12 - 15	841*	△	△	△	763	△	△
	1000	F4 RC	15 - 18	841*	△	△	△	763	△	△
	1000	F4 RR	12 - 17	841*	△	△	△	763	△	△
	1000	F4S	04 - 06	676*		△	△	763	△	△
	1078	F4 CC	08 - 11	841*	△	△	△	763	△	△
	1078	F4 RR	08 - 11	841*	△	△	△	763	△	△
<b>SUZUKI</b>										
GSX-R	250		17 - 18	627		△	△	657	△	△
GSX-R	600		04 - 05	806*	△	△	△	765	△	△
GSX-R	600		06 - 10	806*	△	△	△	833	△	△
GSX-R	600		11 - 18	841*	△	△	△	834	△	△
GSX-R	600		97 - 03	631*		△	△	556	△	△
SV	650	,S ABS	07 - 10	705			△	657	△	△
SV	650	,S ABS	15 - 18	705			△	657	△	△
SV	650	,S Left/Rear	03 - 12	705			△	657	△	△
SV	650	,S Right	03 - 12	704			△			

\* = 2 sets required / 2 jeux pour l'Avant.

△ = Available quality / Qualité disponible.

To select compound for racing front/rear - see page 19-22 / Pour sélectionner vos plaquettes racing avant/arrière - voir page 19-22.

**COMPOUND CHOICE****COMPOUND CHOICE**

<b>SUZUKI</b>				<b>DS</b>	<b>DC</b>	<b>RS</b>		<b>RQ</b>	<b>LS</b>
SV	650 ,S Left/Rear	99 - 02	705			△	556	△	△
SV	650 ,S Right	99 - 02	704			△			
GSX-R	750	04 - 05	806*	△	△	△	765	△	△
GSX-R	750	06 - 10	806*	△	△	△	833	△	△
GSX-R	750	11 - 18	841*	△	△	△	834	△	△
GSX-R	750	94 - 99	686*		△	△	556	△	△
GSX-R	750 Y	00 - 03	631*		△	△	556	△	△
GSX-R	1000	03	788*		△	△	765	△	△
GSX-R	1000	04 - 06	806*	△	△	△	765	△	△
GSX-R	1000	07 - 08	806*	△	△	△	833	△	△
GSX-R	1000	09 - 11	806*	△	△	△	834	△	△
GSX-R	1000	12 - 18	841*	△	△	△	834	△	△
GSX-R	1000	01 - 02	686*		△	△	765	△	△
GSX-R	1000 R	17 - 18	841*	△	△	△	834	△	△
SV	1000 , S	03 - 07	631*		△	△	657	△	△
TL	1000 RW	98 - 02	686*		△	△	556	△	△
TL	1000 S V-Twin	97 - 01	631*		△	△	556	△	△
GSX-R	1100	93 - 97	686*		△	△	556	△	△
<b>TRIUMPH</b>									
	600 Daytona	03 - 04	624*		△	△	614	△	△
TT	600	00 - 03	624*		△	△	614	△	△
	675 Daytona	06 - 08	782*		△	△	614	△	△
	675 Daytona R Triple	11 - 12	901*	△	△	△	614	△	△
	675 Daytona R Triple	13 - 18	901*	△	△	△	675	△	△
	675 Daytona Triple	09 - 12	864*		△	△	614	△	△
	675 Daytona Triple	13 - 18	864*		△	△	675	△	△
<b>YAMAHA</b>									
TZ	125	97 - 00	624		△	△	659	△	
TZ	250	02 - 05	624*		△	△	659	△	
TZ	250	90 - 01	624*		△	△	659	△	
YZF	321 R3	15 - 18	931	△	△	△	932	△	
YZF	600 R6	99 - 02	634*	△	△	△	728	△	△
YZF	600 R6	03 - 04	634*	△	△	△	657	△	△
YZF	600 R6	05 - 16	634*	△	△	△	657	△	△
YZF	600 R6	17 - 18	634*	△	△	△	834	△	△
YZF	750 R, SP	93 - 97	683*			△	555	△	△
YZF	750 R7 OW02	99 - 02	634*		△	△	733	△	△
YZF	750 R7 OW02 Race kit	99 - 01	729*		△	△			
YZF	1000 R1	98 - 01	634*	△	△	△	733	△	△
YZF	1000 R1	02 - 03	634*	△	△	△	728	△	△
YZF	1000 R1	04 - 06	634*	△	△	△	657	△	△
YZF	1000 R1(4-pad)	07 - 14	839*	△	△	△	657	△	△
YZF	1000 R1(4-pad) ABS	12 - 14	839*	△	△	△	657	△	△
YZF	1000 R1	15 - 18	634*	△	△	△	834	△	△
YZF	1000 R1 LE	06	634*	△	△	△	657	△	△
YZF	1000 R1M	15 - 18	634*	△	△	△	834	△	△
YZF	1000 R1S	16	634*	△	△	△	834	△	△

Applications  
Racing

\* = 2 sets required / 2 jeux pour l'Avant.

△ = Available quality / Qualité disponible.

To select compound for racing front/rear - see page 19-22 / Pour sélectionner vos plaquettes racing avant/arrière - voir page 19-22.





# CALIPERS



**ACCOSSATO**

AGPZ01, 108 mm CNC Monoblock, 4 Piston/4 Pad	805
AGPZ02, 108 mm Forged Monoblock, 4 Piston/4 Pad	805
AGPZ03, 108 mm Forged Monoblock, 4 Piston/4 Pad	805
AGPZ04, 108 mm Forged Monoblock, 4 Piston/4 Pad	805
AGPZ05, 100 mm CNC Monoblock, 4 Piston/2 Pad	845
AGPZ06, 60 mm CNC Moto 3, 2 Piston/2 Pad	805
AGPZ07, 100 mm Forged Monoblock, 4 Piston/2 Pad	845

**A.P. RACING CALIPERS**

6 Piston 3366/3367 Series	660
6 Piston 4466/4477 Series	707
CP-2382/2383	569
CP-2696-36E0/38E0	523
CP-2868-8E0/9E0	698
CP-3369-2E0/3E0	599
CP-3385-2E0/3E0	599
CP-3386-2E0/3E0	599
CP-3485-8S0/9S0	661
CP-3548	718
CP-3569-2S0/3S0	599
CP-3569-4S0/5S0	661
CP-3586-4S0/5S0	661
CP-3696-2E0	523
CP-3697-2E0	523
CP-3769-2S0/3S0	599
CP-4226-2S0/3S0	719
CP-4484-2S0/3S0	720
CP-4485	751
CP-4488 Two Pad Radial 4 Piston Monoblock	785
CP-4638-2E0	523
CP-4679-2S0/3S0	751
CP-6688 Four Pad Radial 4 Piston Monoblock	805

**BERINGER**

2 Piston Classic Billet Caliper	506
4 Piston Caliper	631
6 Piston Caliper	771
6 Piston Endurance Caliper	779

**BRAKING**

Front cross	694
Front Harley Davidson	676
Rear cross (1 piston)	777
Rear cross (2 piston)	604
Street, Supermotard	706

**BREMBO RACING CALIPERS**

100 mm Motard Radial XA78910, P4 30/34	706
100 mm Radial 220A16810, P4 30/34	706
100 mm Radial 220A80310, P4 30/34	706
100 mm Radial Caliper .484, 220B47310, P4 32	841
100 mm Radial Monoblock 220988530, P4 34	841
100 mm Radial Monoblock XA7G210/11, P4 32/36	711
100 mm Radial Monoblock XA7G240/41, P4 32/36	711
108 mm Motard Radial XA69510, P4 30/34	706
108 mm Radial 220A01610, P4 30/34	706
108 mm Radial 220A80210, P4 30/34	706
108 mm Radial Caliper .484, 220B47310, P4 32	841
108 mm Radial Monoblock 220A39710, P4 34	841
108N, P2 38	506
Billet 20.4756.52/62, racing	566
Billet P2.24 X20.60.01, racing	732
F08	506
Floating Motocross Caliper 22.5930.62	671
Goldline 20.5161.42/51, road	519
Goldline 20.6951.50, road	730
Goldline 4 pad 20.7850.11/21, road	762
Goldline single pin 20.5165.55/65, road	566

**BREMBO RACING CALIPERS**

Goldline two pin 20.6800, road	706
GP X10.48.13/14, racing	695
Monoblock X101740/41, P4 32/36	711
Motard Axial XA32950, P4 34	762
Moto3/SBK XA88810/11, P2 34	887
Moto3/SBK XA88820/21, P2 34	887
Motocross Caliper 22.2180.20	675
Off Road 122A99021, P2 24	671
Off Road XQ21361, P2 28	671
Off Road XQ21390, PF 26	791
Racing rear X206001, P2 24	759
Racing rear X206101, P4 24 (24 mm disc height)	942
Racing rear X206101, P4 24 (30 mm disc height)	941
Racing rear X206121, P4 24 (24 mm disc height)	942
Racing rear X206121, P4 24 (30 mm disc height)	941
Racing rear X988870, P2 34 (24 mm disc height)	942
Racing rear X988870, P2 34 (30 mm disc height)	941
Racing rear XA1J040, P2 30 (24 mm disc height)	942
Racing rear XA1J040, P2 30 (30 mm disc height)	941
Radial 220A16820, P4 30/34	706
Radial GP4 RX 220B01010	841
Radial Monoblock X973760/61, P4 32/36	711
Radial Monoblock X99C460/61, P4 34	805
Radial Monoblock XA8Y310/11	845
Radial Monoblock XA93310/11	711
Radial XA3B830/31, P4 32/36	711
Radial XA3B860/61, P4 32/36	711
SBK Racing DX XB0.B1.31, P4 30/34	889
SBK Racing DX XB0.B1.31, P4 30/34 (for Radiators X93.12.50)	909
SBK Racing SX XB0.B1.30, P4 30/34	889
SBK Racing SX XB0.B1.30, P4 30/34 (for Radiators X93.12.50)	909
Supersport 120A44110, P2 34	730

**GMA**

2 Piston Caliper, large Model A	512
2 Piston Caliper, small Model B	560
4 Piston front Model F	559

**HARRISON/BILLET CALIPERS**

4 Piston Billet	737
Big-6	737
Mini-6	656

**HHI**

4 Piston Caliper	678
6 Piston Caliper	676

**ISR CALIPERS**

2 Piston (22-023/026)	504
2 Piston (22-027/028/029)	519
2 Piston (22-030/033)	523
2 Piston (22-036)	655
4 Piston (22-025)	519
4 Piston (22-043)	655
6 Piston Racing Caliper, large	656
6 Piston Racing Caliper, small	655

**JAYBRAKE**

2 Piston Caliper ADC/ADCS	560
2 Piston Dual Series Caliper	559
4 Piston Caliper A4 P/L	686
4 Piston J-Four Caliper	686
4 Piston Quad Series Caliper	559

**MOTO-MASTER**

Supermoto Racing Caliper	631
--------------------------	-----

\* = 2 sets required / 2 jeux pour l'Avant.

Compound selection, see under "Brake pad drawings" / Sélection de composés, voir sous les schémas des plaquettes de frein.







# BRAKE PADS

1:1 DRAWINGS, COMPOUNDS, FITMENTS

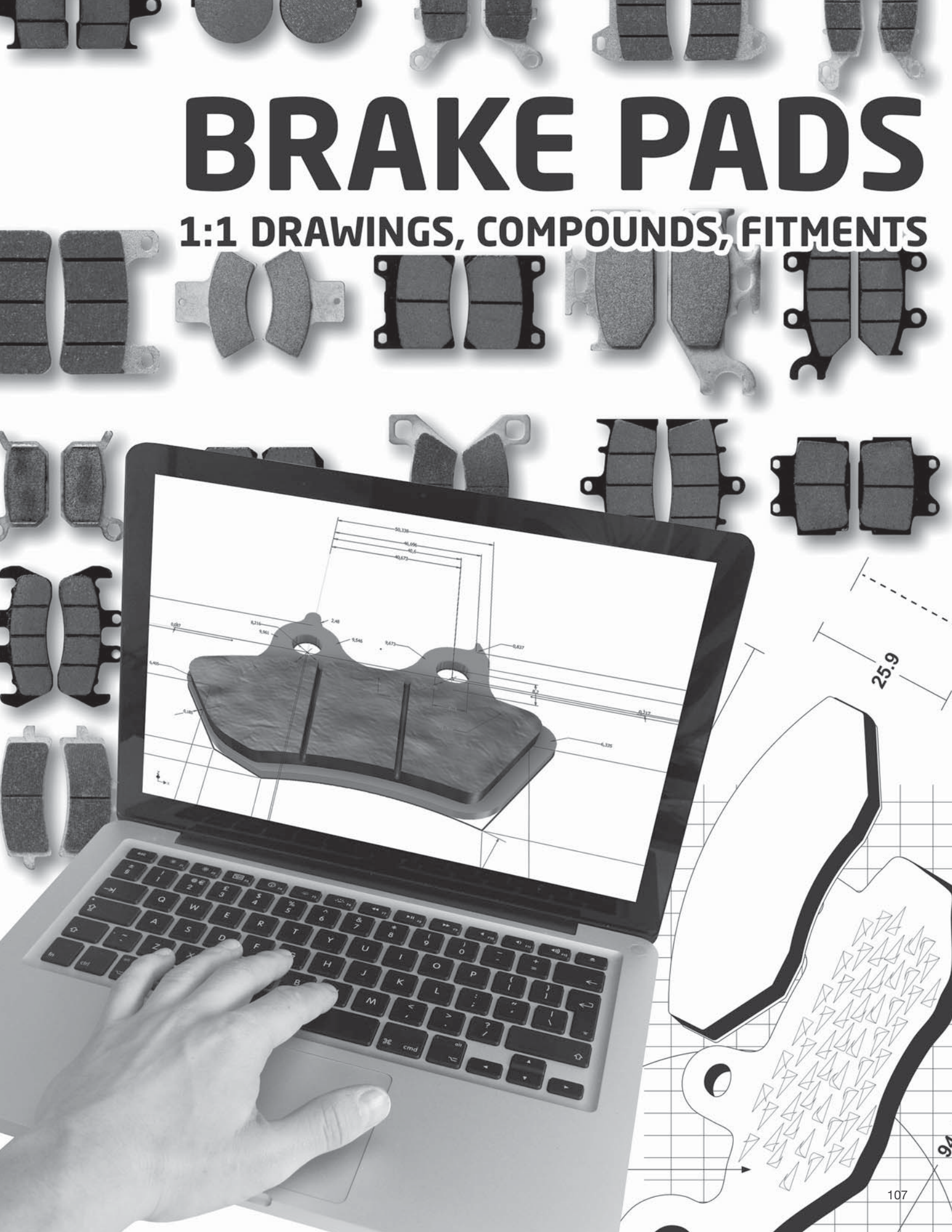





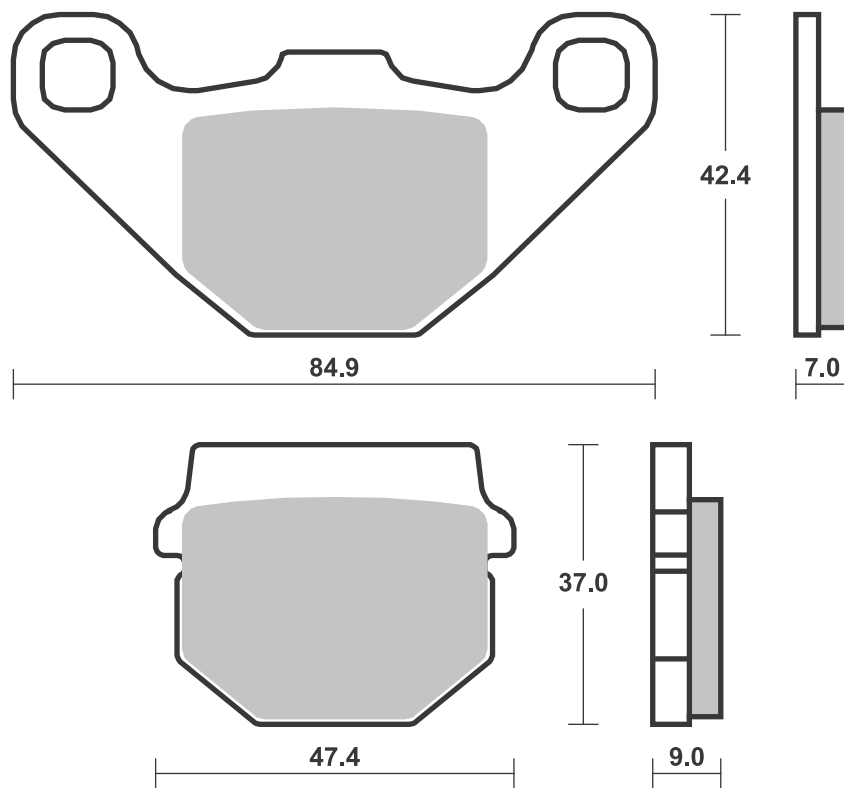
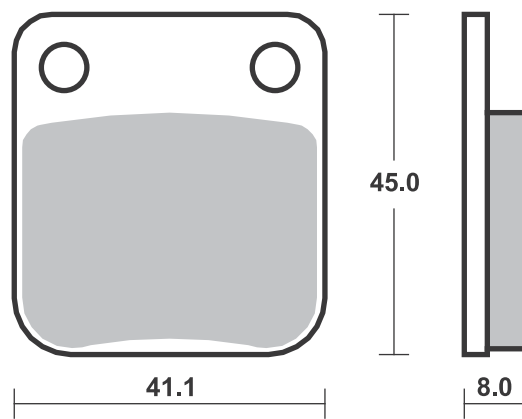





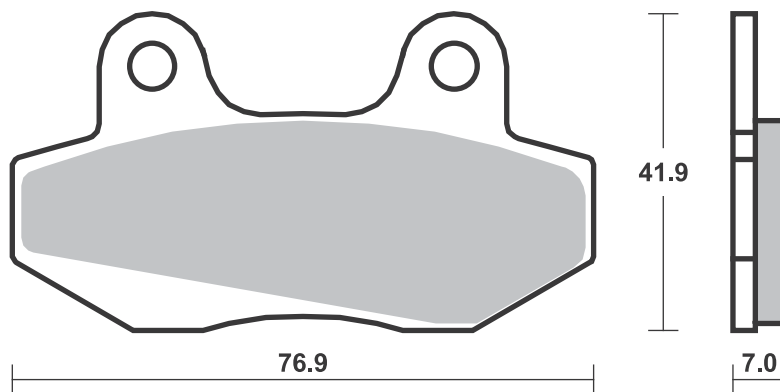
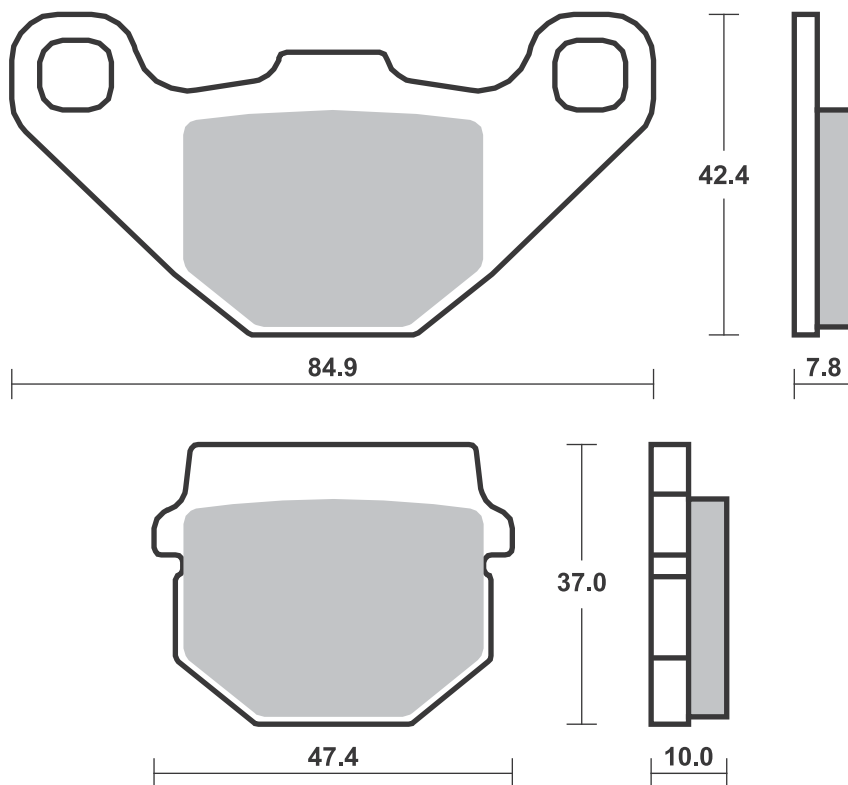



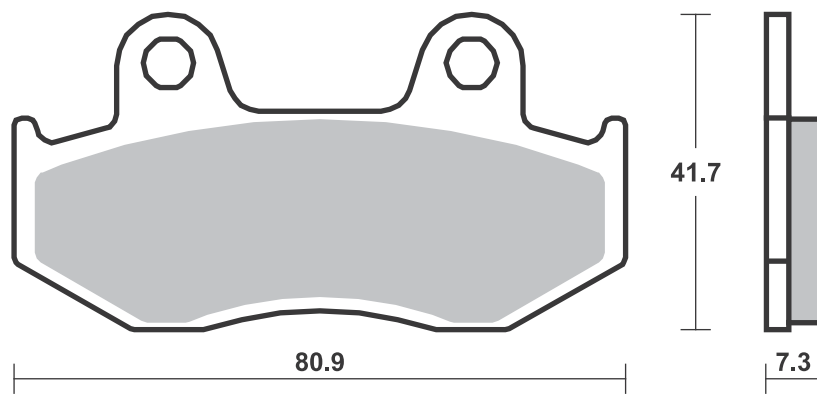

*If required with springs - see SBS 188*

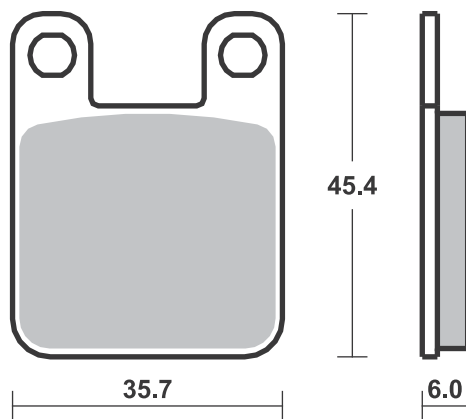





*If required with springs -  
see SBS 188*

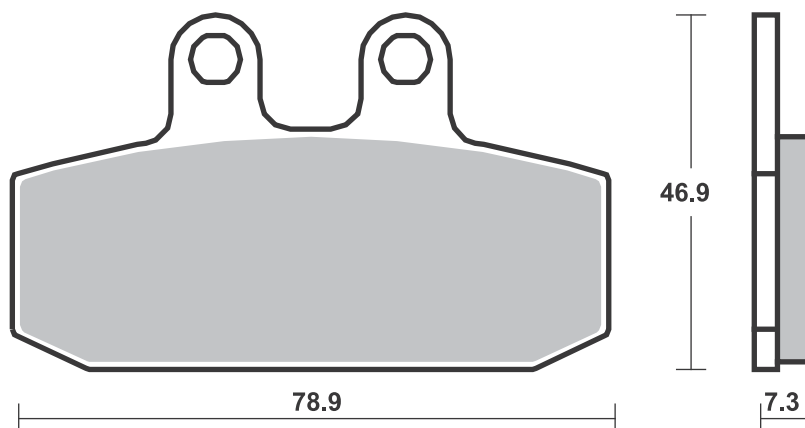
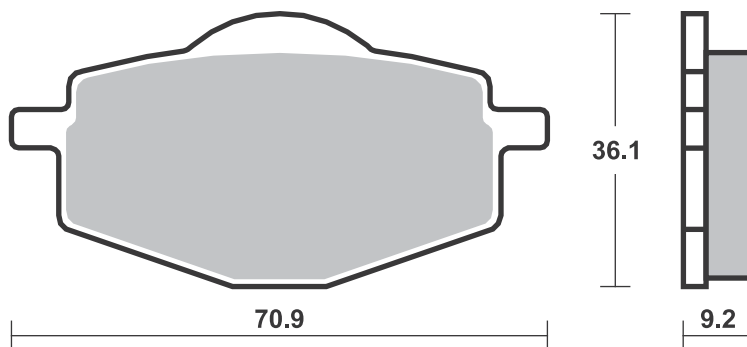
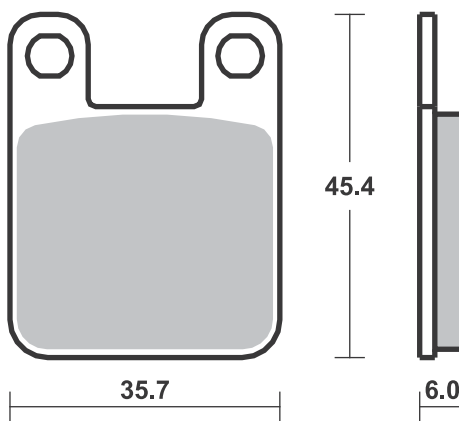





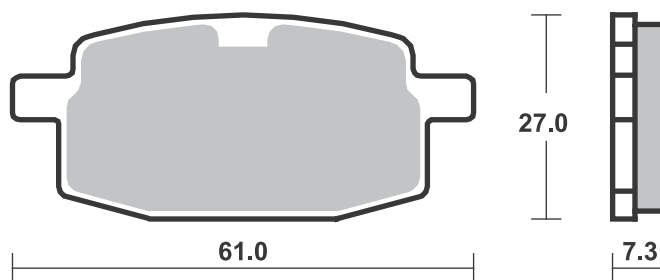
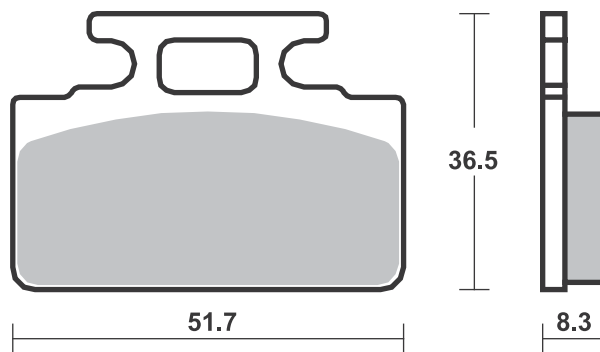
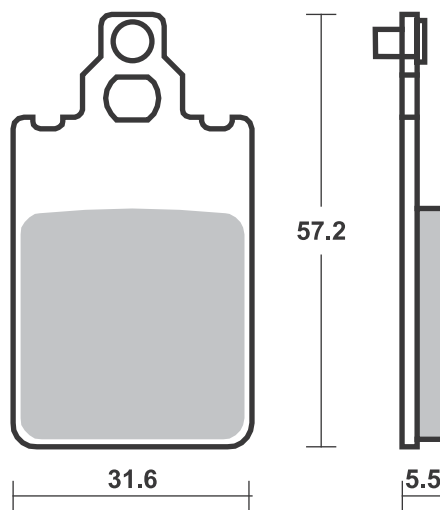



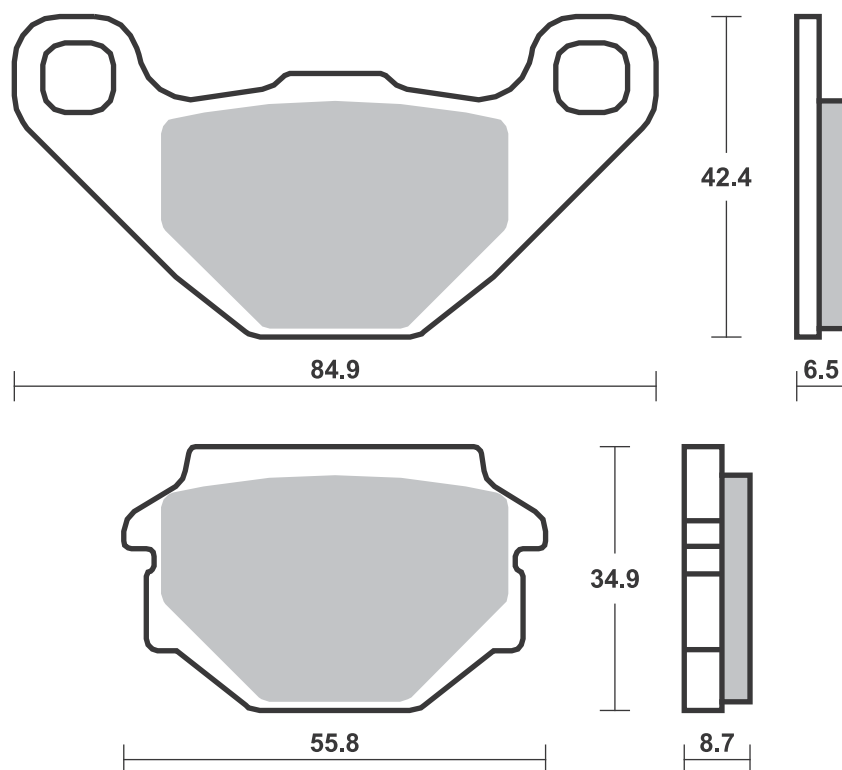
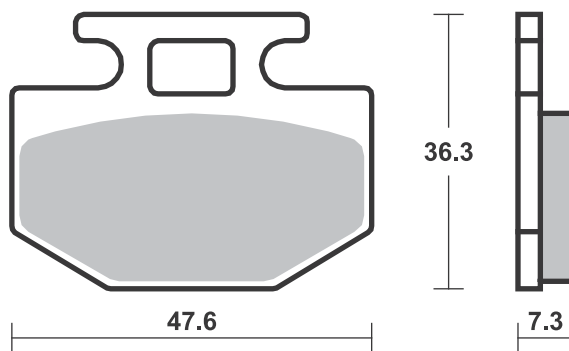





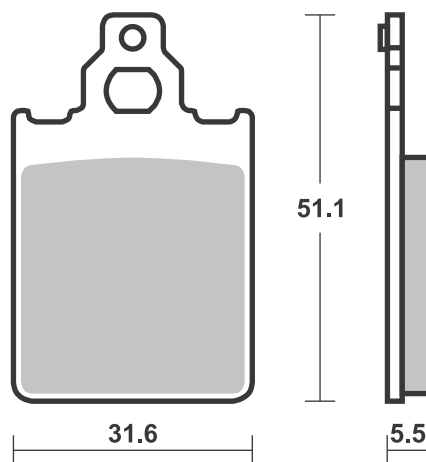
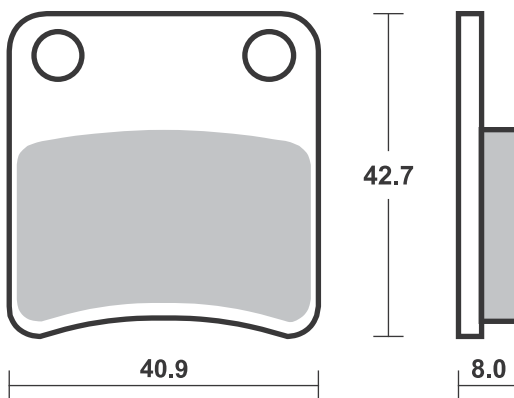
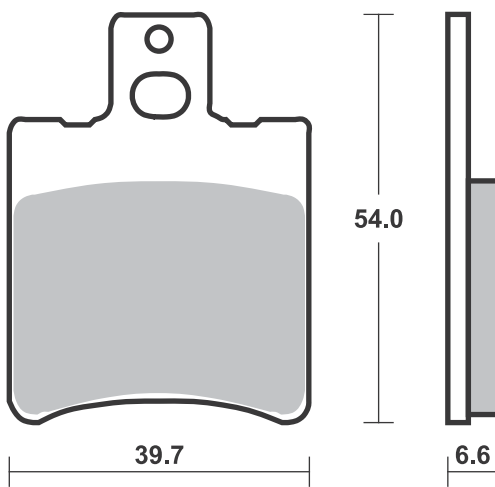





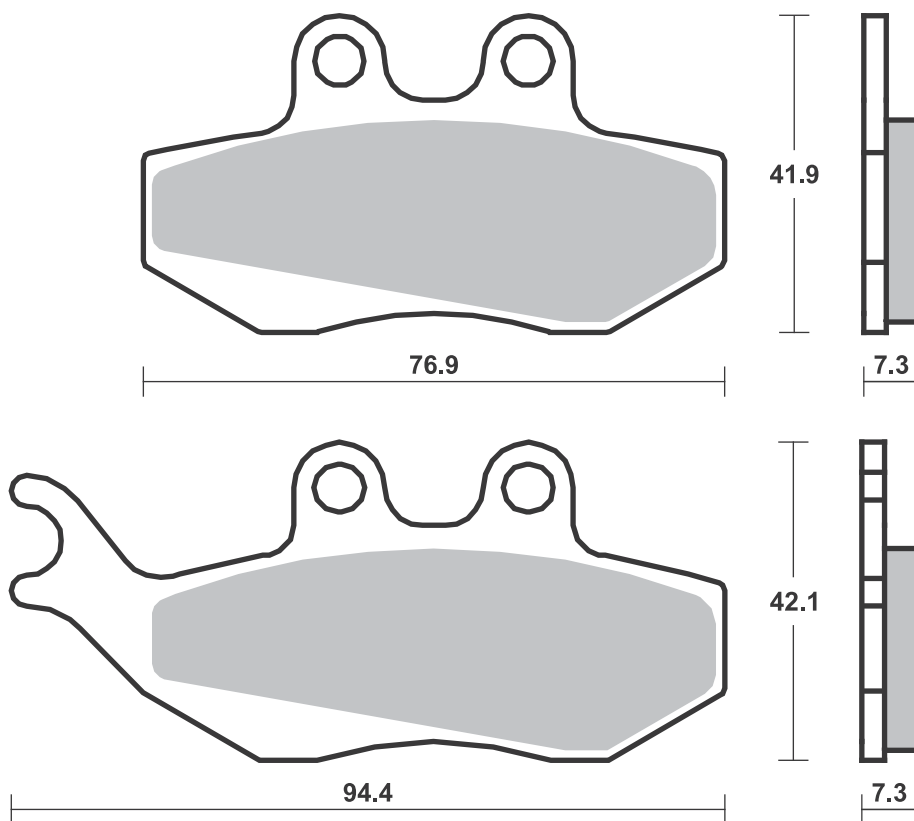
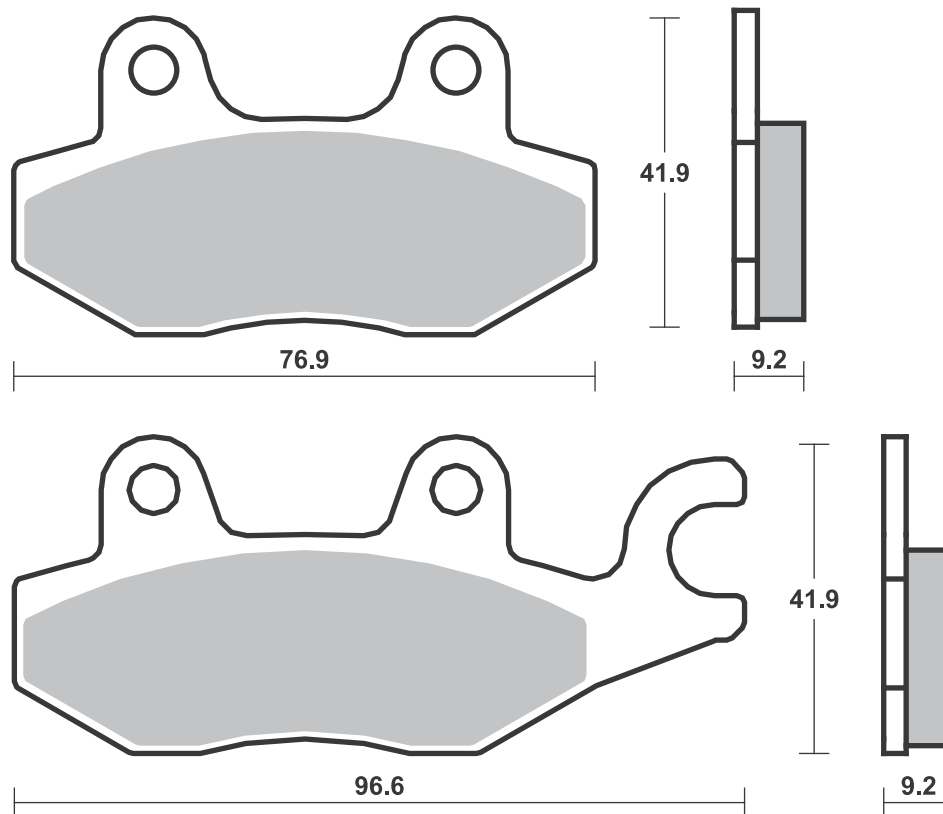



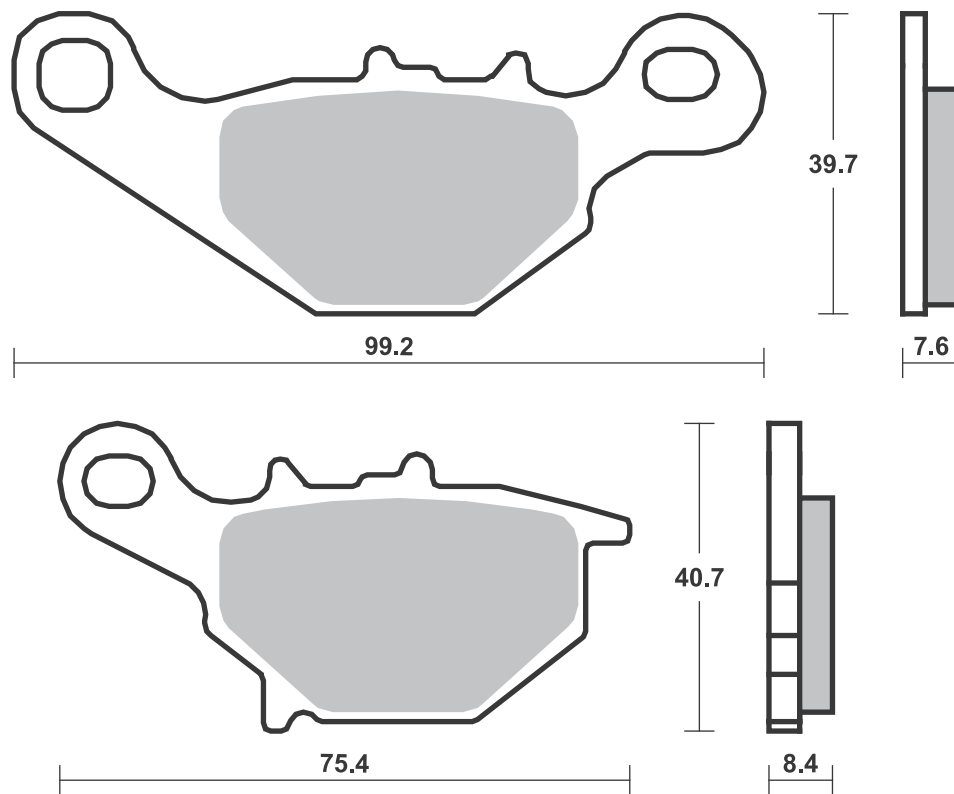
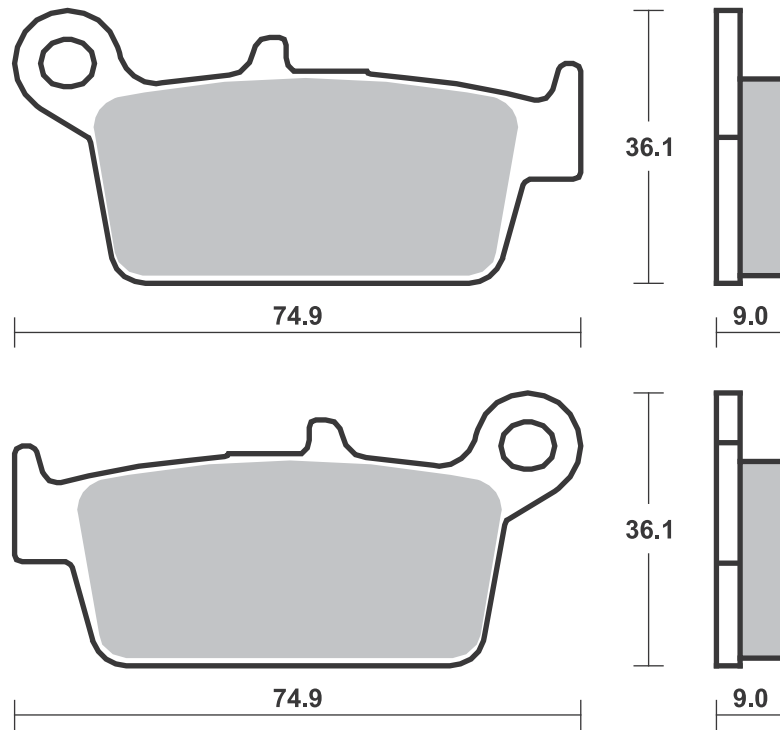





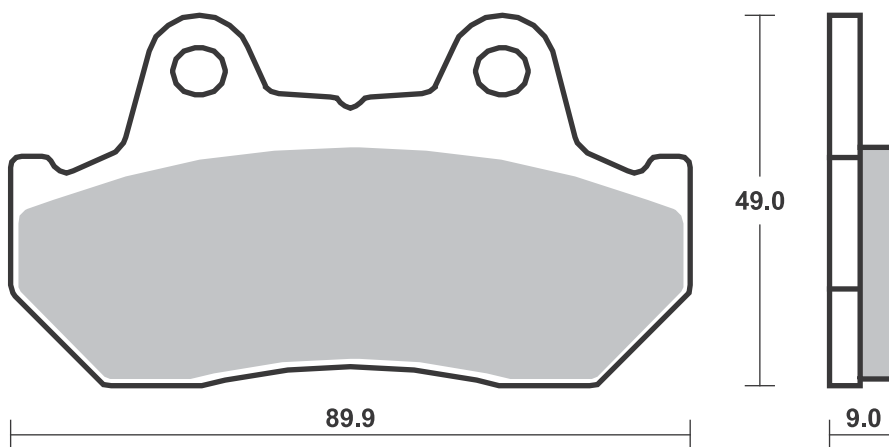
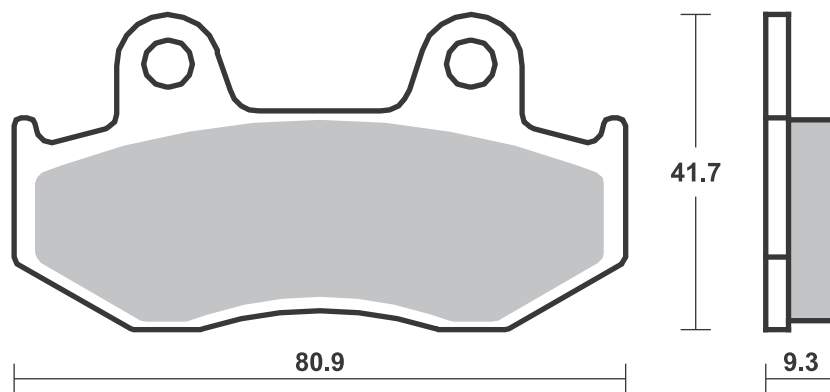
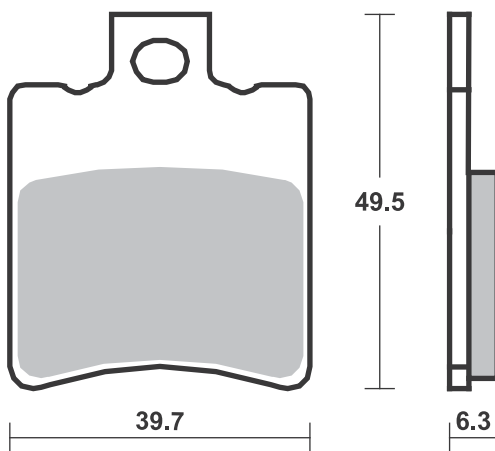

**SBS 128** Recommended compound

<b>ITALJET</b>			
	125 Jupiter	02-03	<b>CT</b>
	150 Jupiter	02-03	<b>CT</b>
	250 Jupiter	01-03	<b>CT</b>
<b>YAMAHA</b>			
YP	250 D Majesty DX	98-00	<b>MS</b>
YP	250 Majesty	96-04	<b>MS</b>
YP	250 Majesty DX/ABS	99-14	<b>MS</b>
YP	400 Majesty	05-13	<b>MS</b>
XP	500 TMAX	04-07	<b>MS</b>

**SBS 129** Recommended compound

<b>SYM</b>			
	50 Jet Sport X SR	06-14	<b>HF</b>

**SBS 132** Recommended compound

<b>KEEWAY</b>				
	125 Speed	06-12	<b>CT</b>	
	150 Speed	06-09	<b>CT</b>	
<b>MALAGUTI</b>				
	50 Enduro Dune	87-88	<b>HF</b>	<b>HF</b>
CR-1	50 Crosser	95-96	<b>HF</b>	
F-12	50 Phantom	94-98	<b>HF</b>	
F-15	50 Fire Fox	96-99	<b>HF</b>	
RST	50 Sport	87	<b>HF</b>	<b>HF</b>
<b>TGB</b>				
	50 Corona	03-05	<b>HF</b>	
R	50 X	06-14	<b>HF</b>	

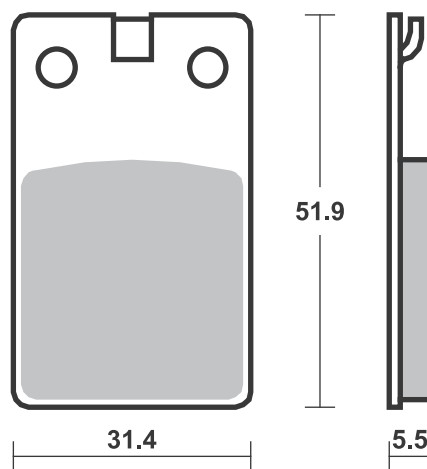
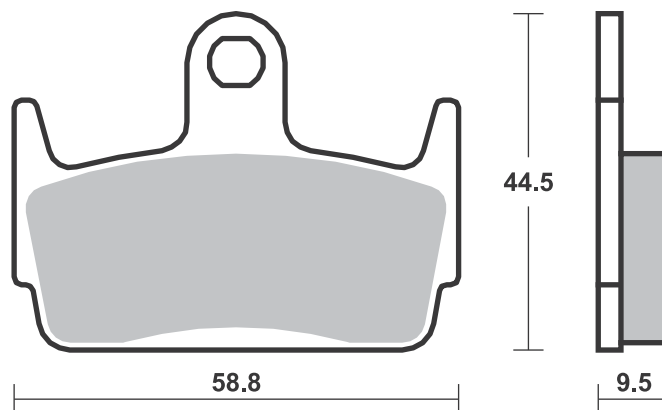
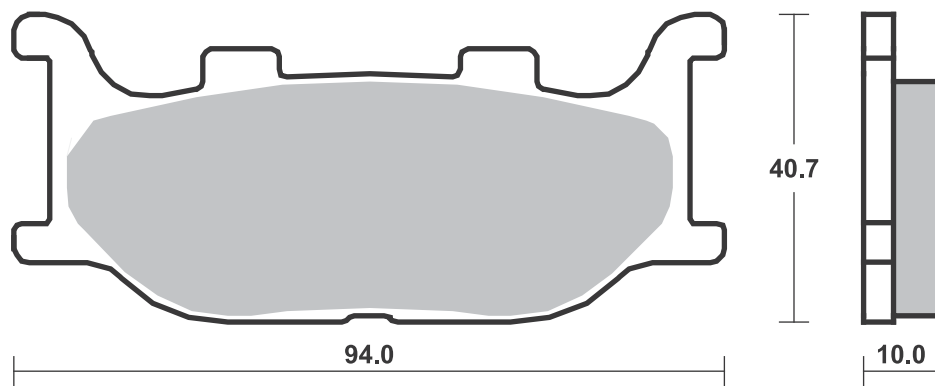





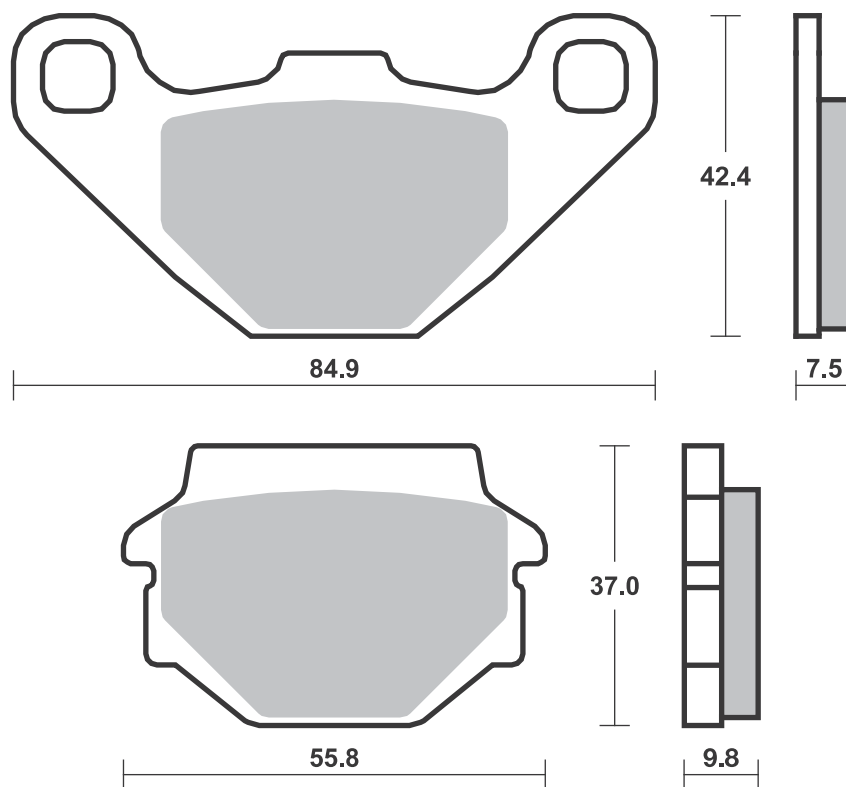
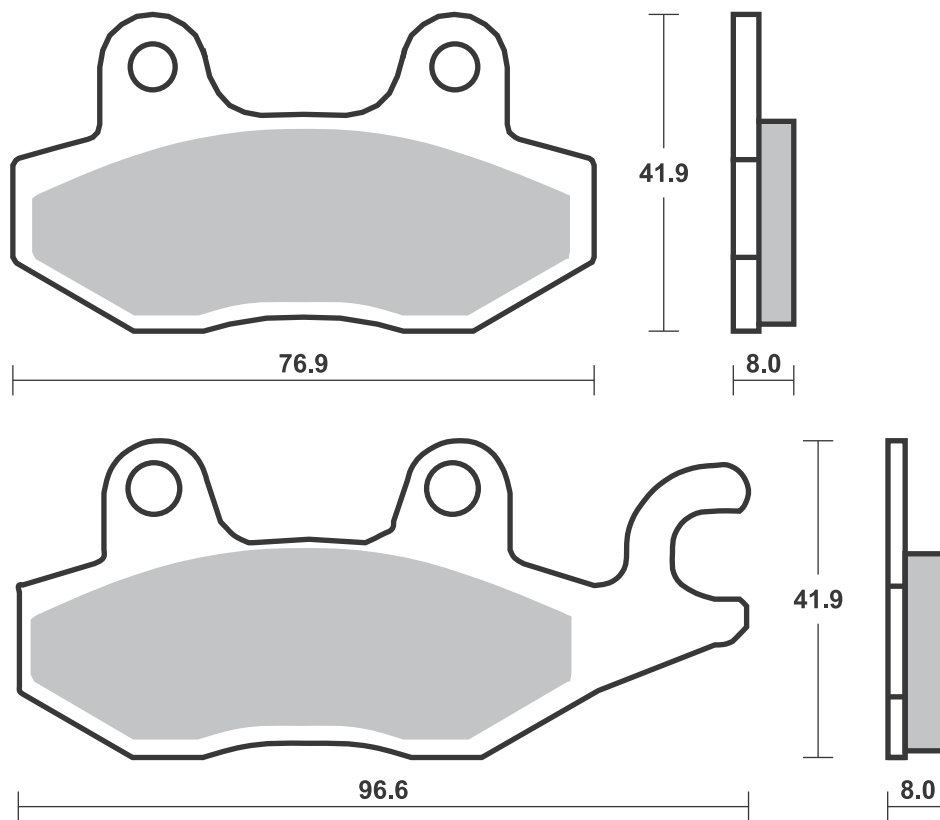



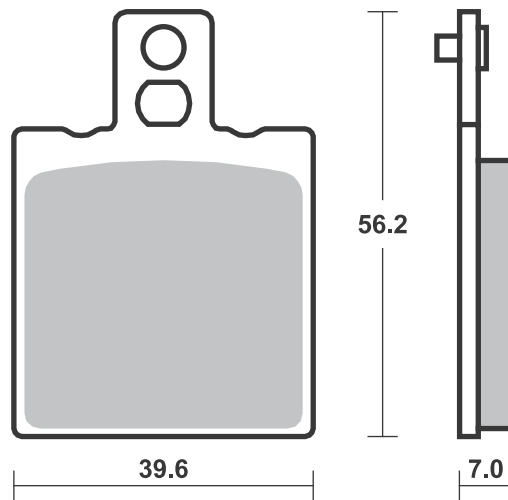
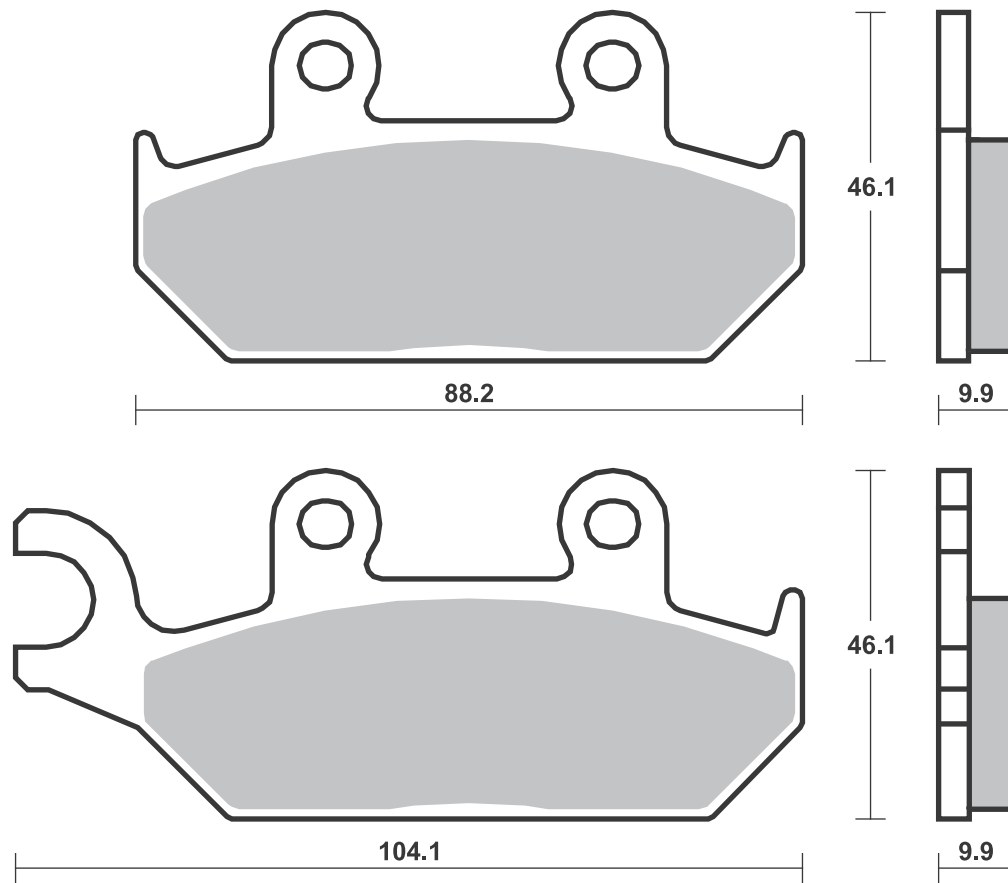



**SBS 140** Recommended compound

SYM			
50 Allo	11-15	HF	
50 Crox	14-15	CT	
50 Fiddle	09-14	HF	
50 Fiddle III	16-18	CT	
50 Jet 4 Naked	11-13	HF	
50 Jet 4 R	11-13	HF	
50 Jet BasiX	07-09	HF	
50 Jet Euro X	05-12	HF	
50 Jet Sport X	06-14	HF	
50 Jet Sport X SR	06-14	HF	
50 Jet, Alpha	95-97	HF	
50 Jungle	96-02	HF	
50 Mask	00-05	HF	
50 Mask LC	00-05	HF	
50 Orbit II	12-13	HF	
50 Red Devil	97-09	HF	
50 Super Fancy	95-97	HF	
50 Symphony	09-15	HF	
50 Symphony SR	11-15	HF	
50 Symphony ST	15	CT	
50 Symply	08-14	HF	
50 X'Pro	13-17	HF	
100 Jet	00	HF	
100 Jet Euro X	05	HF	
100 Jet Sport X	05	HF	
100 Party	97-00	HF	
100 Super Fancy	95-00	HF	
110 Star	03	HF	
125 Allo	11-15	CT	
125 Citycom	09-14	CT	



SYM			
125 Crox	14-15	CT	
125 Fiddle	09-16	CT	
125 Fiddle III	16-18	CT	
125 Jet 14	17-18	CT	
125 Jet 4	11-13	HF	
125 Megalo	02-05	CT	
125 New Duke	02-07	CT	
125 Super Duke	95-01	CT	
125 Symphony	09-15	CT	
125 Symphony EX	17	CT	
125 Symphony S	11-17	CT	
125 Symphony SR	11-17	CT	
125 Symphony ST	15-18	CT	
125 Symply	08-14	CT	
125 X'Pro	14-16	CT	
HD 125 Evo DT	10	CT	
HD2 125 Evo	14	CT	
150 Attila	00-03	CT	
150 Crox	14-16	CT	
150 Jet 4	11-14	HF	
150 Super Duke	96-01	CT	
150 Symphony S	11-15	CT	
150 Symphony SR	11-15	CT	
200 Fiddle II	11-13	CT	
200 Fiddle III	16-18	CT	
200 Joyride Evo	09-15	CT	
HD 200 Evo	07-13	CT	
HD2 200 Evo	14	CT	
300 Citycom	09-15	CT	CT
300 Citycom S	15-17	CT	CT

**SBS 141** Recommended compound

GPI			
50 Aragon Club	07-09	HF	
50 Aragon GP	06-09	HF	
50 Aragon SP	07-09	HF	
50 Freaky	07	HF	
50 Hussar	03-06	HF	
50 Oliver	03-12	HF	
50 Oliver City	03-12	HF	
50 Oliver Sport	03-12	HF	
50 Popcorn	03-06	HF	
125 Aragon GP	07-12	CT	

ITALJET			
SX1 50	08-10	HF	

KEEWAY			
50 Flash Electric	10-12	HF	
50 Focus	06-15	HF	
50 Matrix	06-15	HF	
50 Matrix Electric	10-15	HF	
50 Matrix Racing			
Sport	10-16	HF	
F-NKD 50	10-11	HF	
RY8 50	07-16	HF	
125 Focus	06-08	CT	
125 Matrix	06-08	CT	
125 Matrix Racing			
Sport	10-16	CT	
150 Focus	06-09	CT	
150 Matrix	06-08	CT	



KEEWAY			
150 Matrix Racing			
Sport	10-12	CT	

PEUGEOT			
e-Vivacity	11-15	HF	
50 Vivacity			
Sportline	11	HF	

TGB			
GT 50 Veloce	09-12	HF	

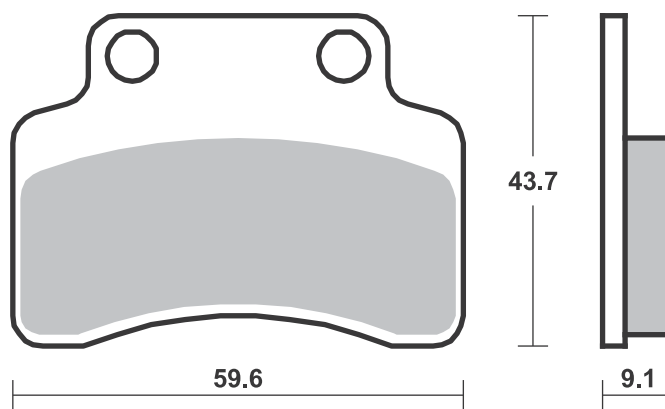
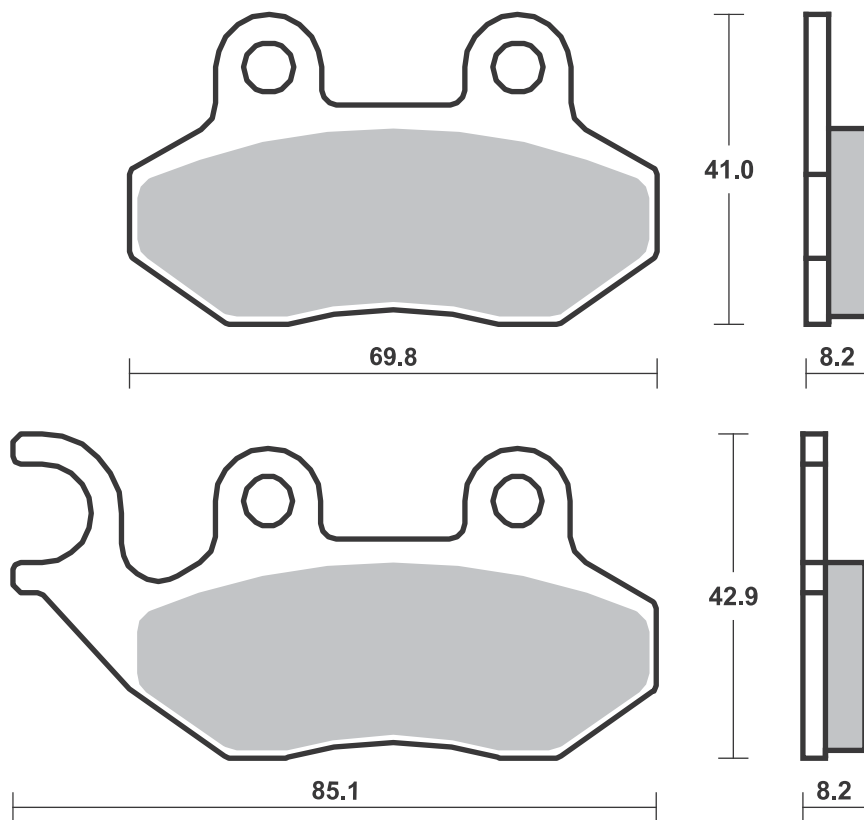



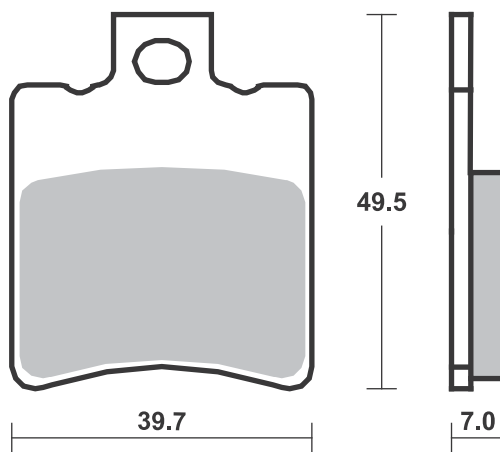
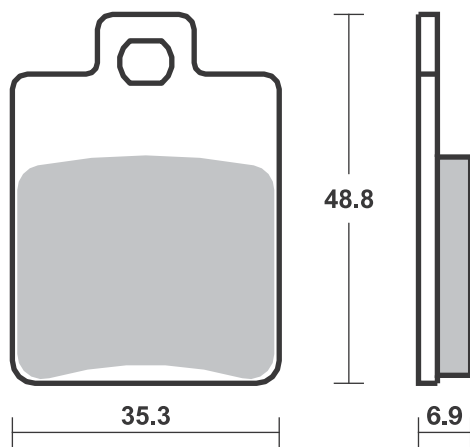





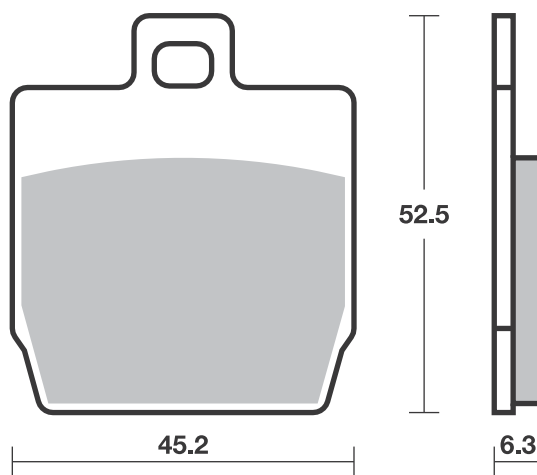
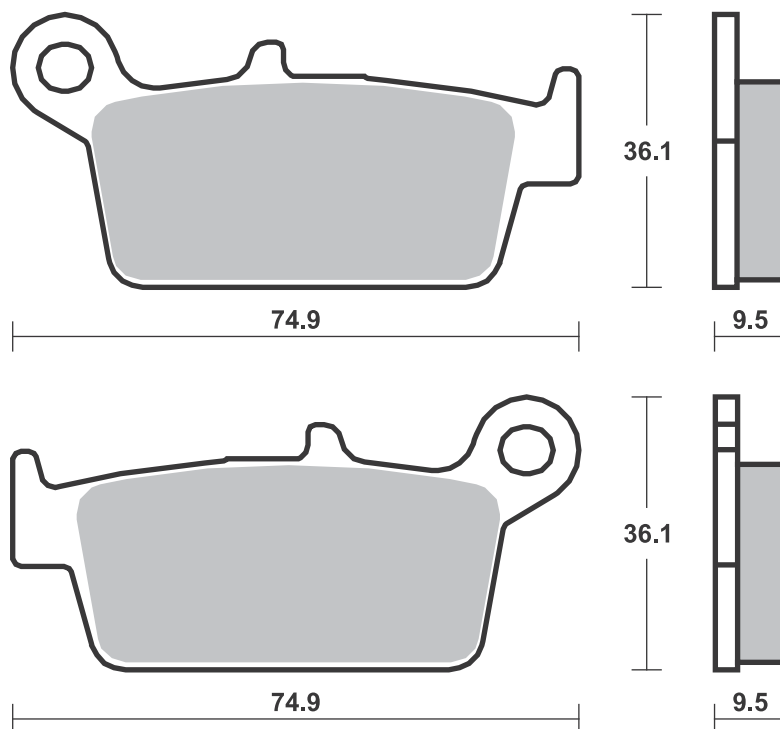



Available compounds

HF • CT • MS

SBS 146

1 set = 4 pcs.

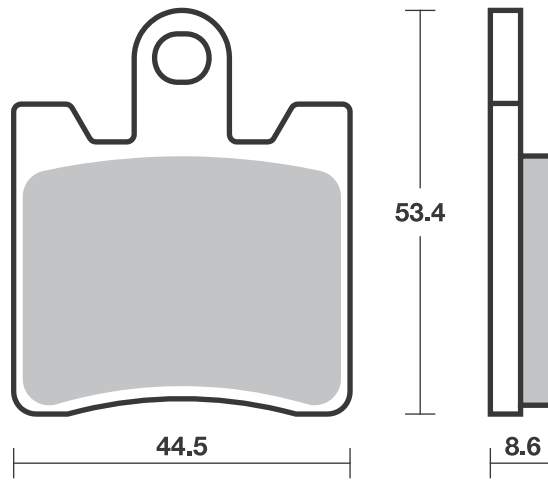

Available compounds

HF • CT

SBS 148

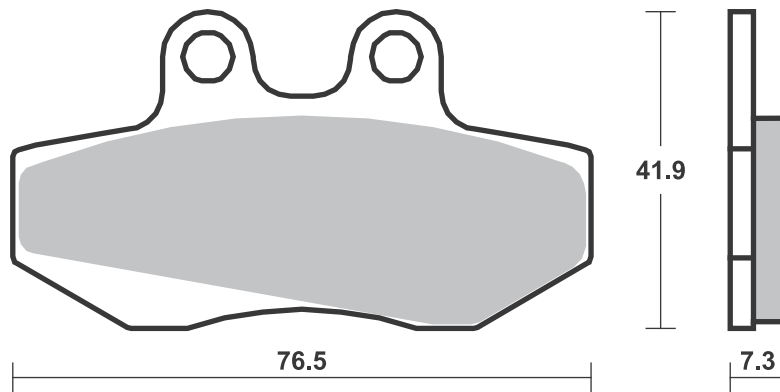

Available compounds

HF • CT

SBS 149

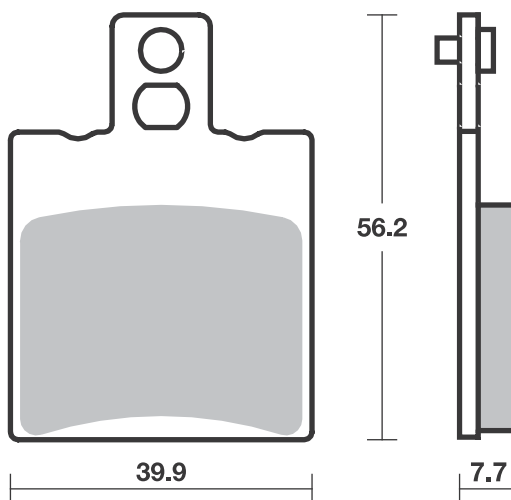





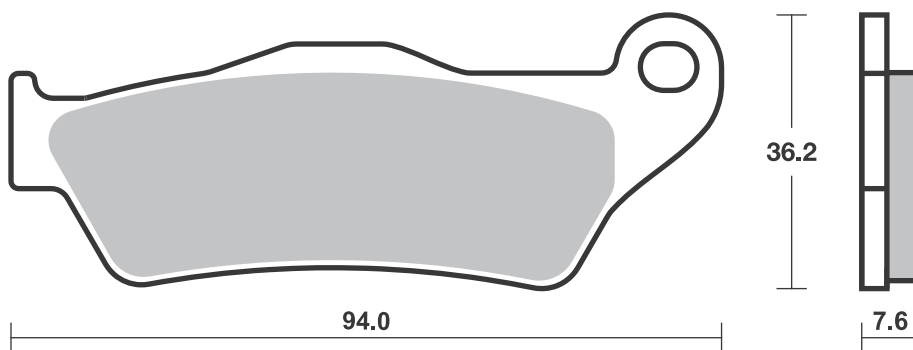
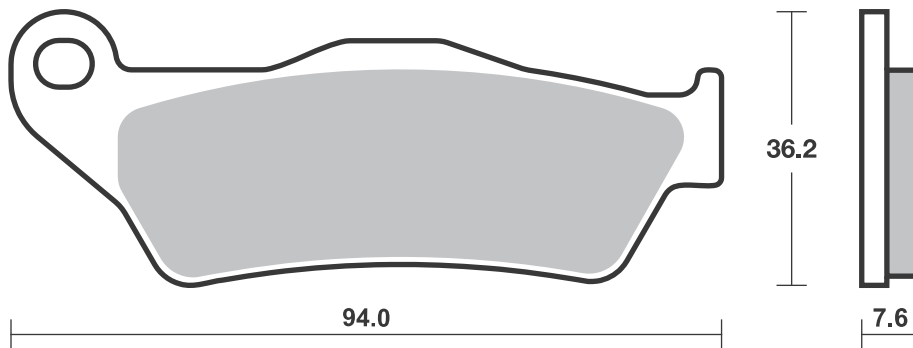
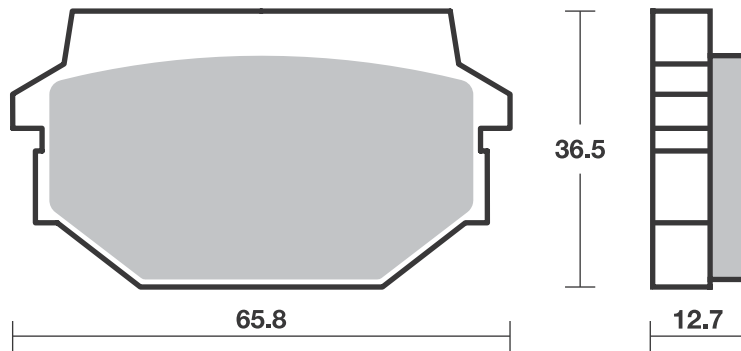
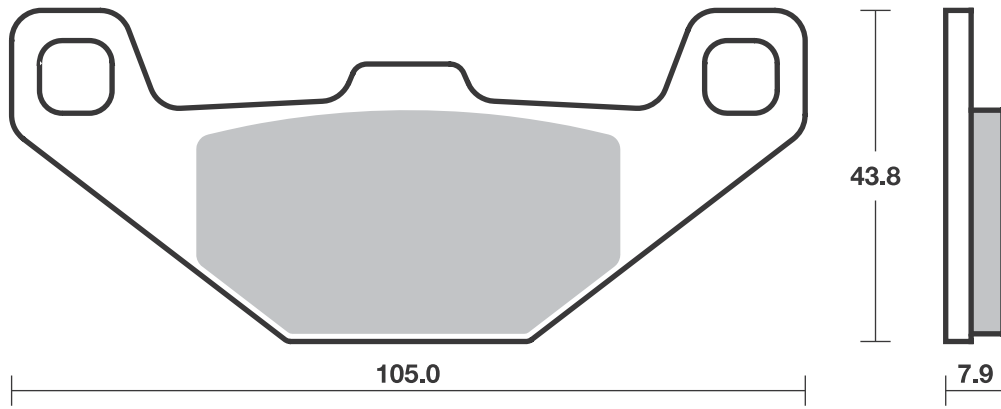



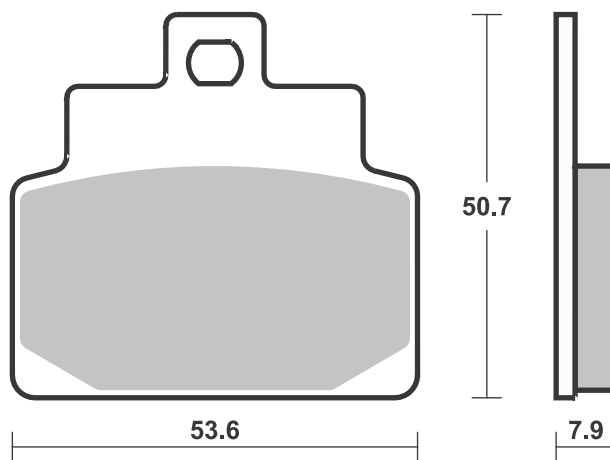
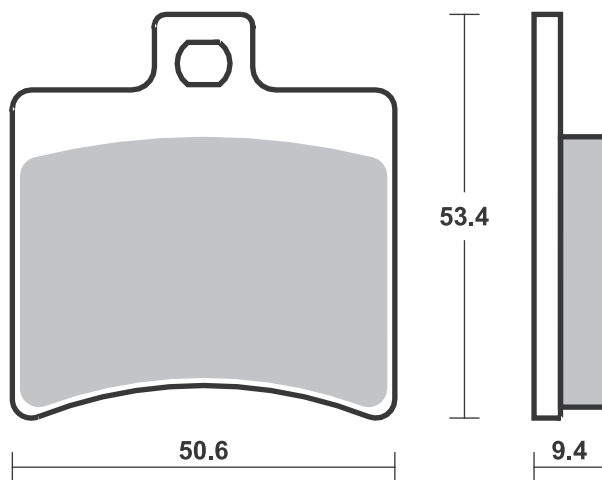





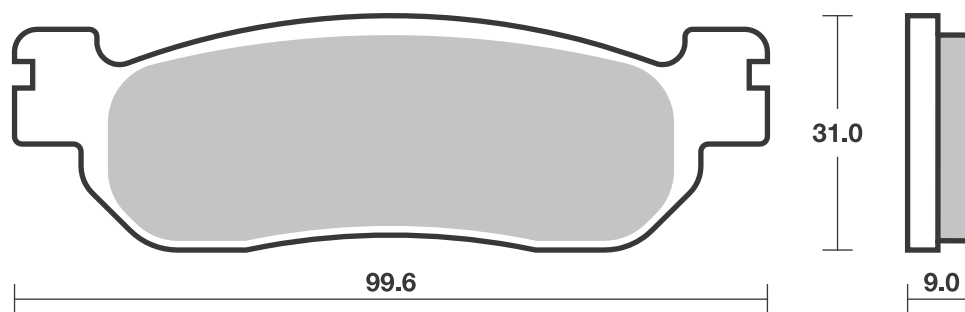
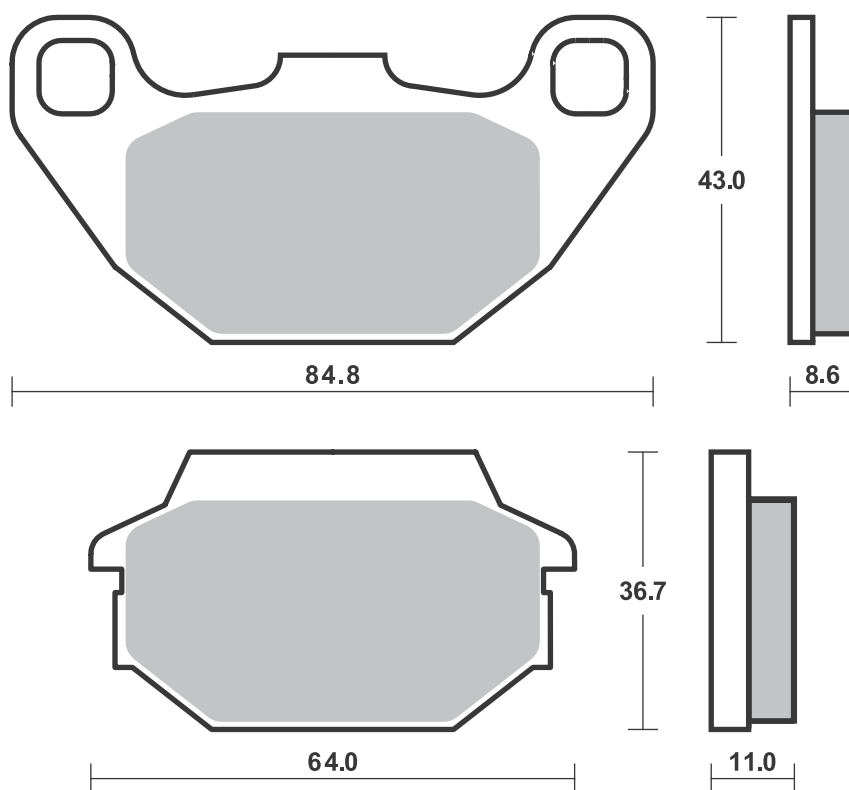



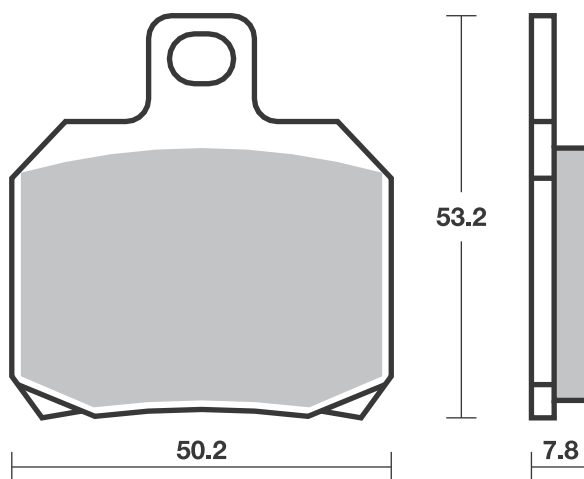
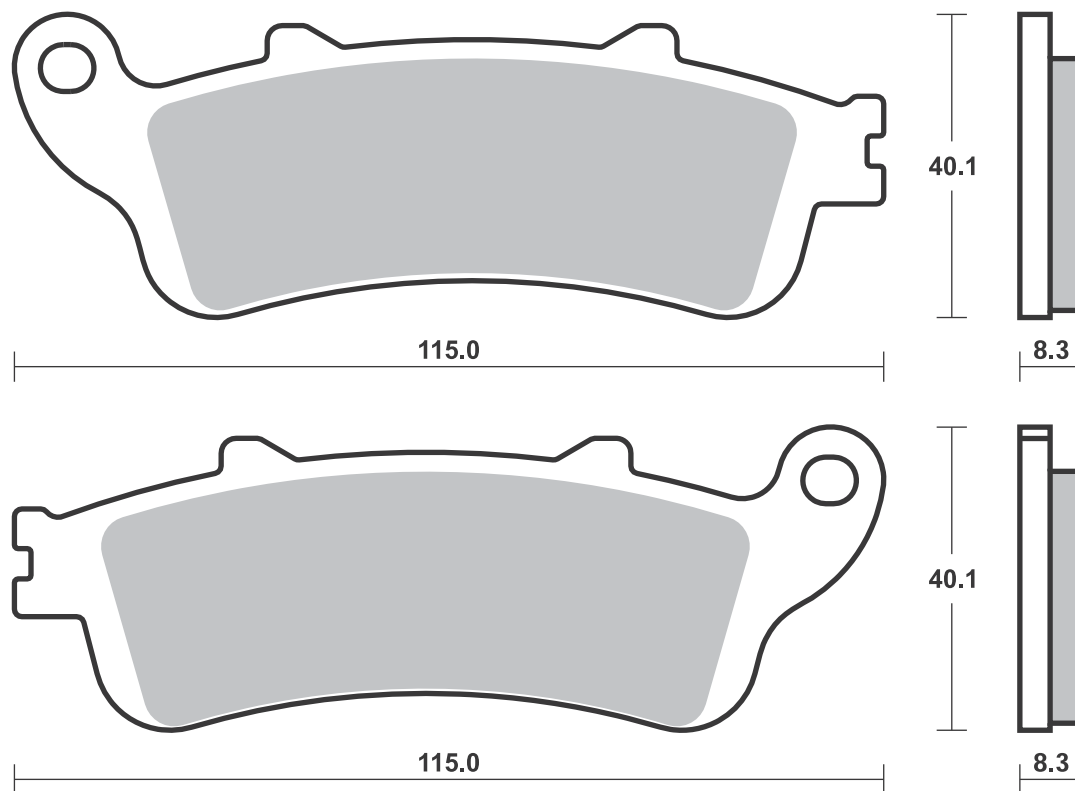





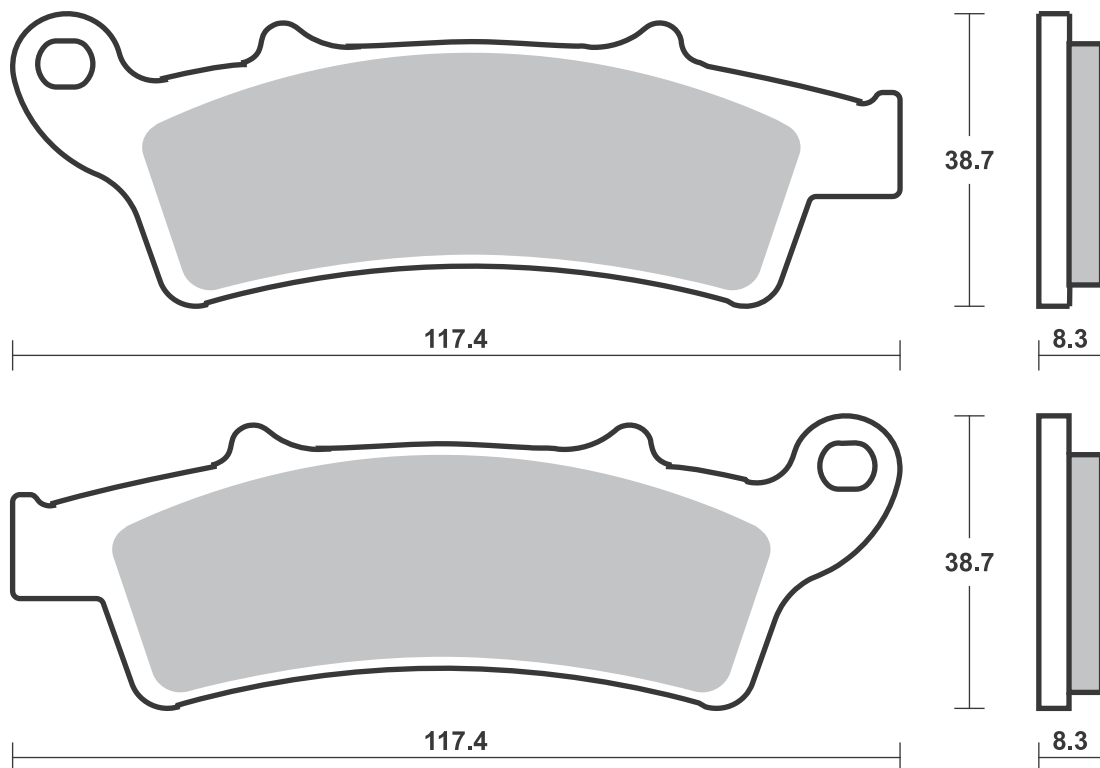
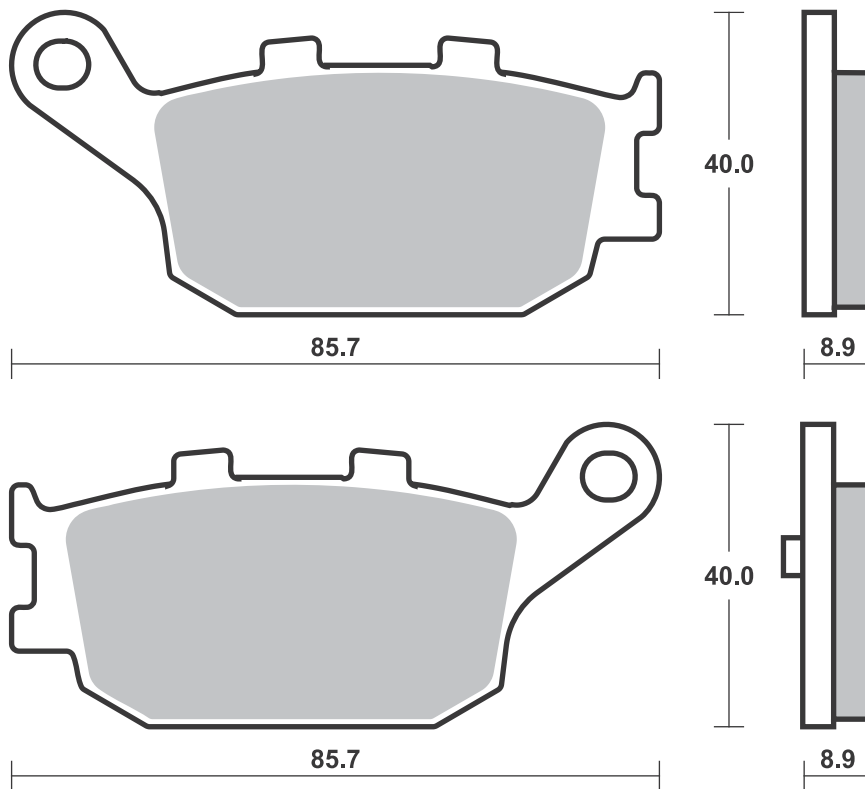



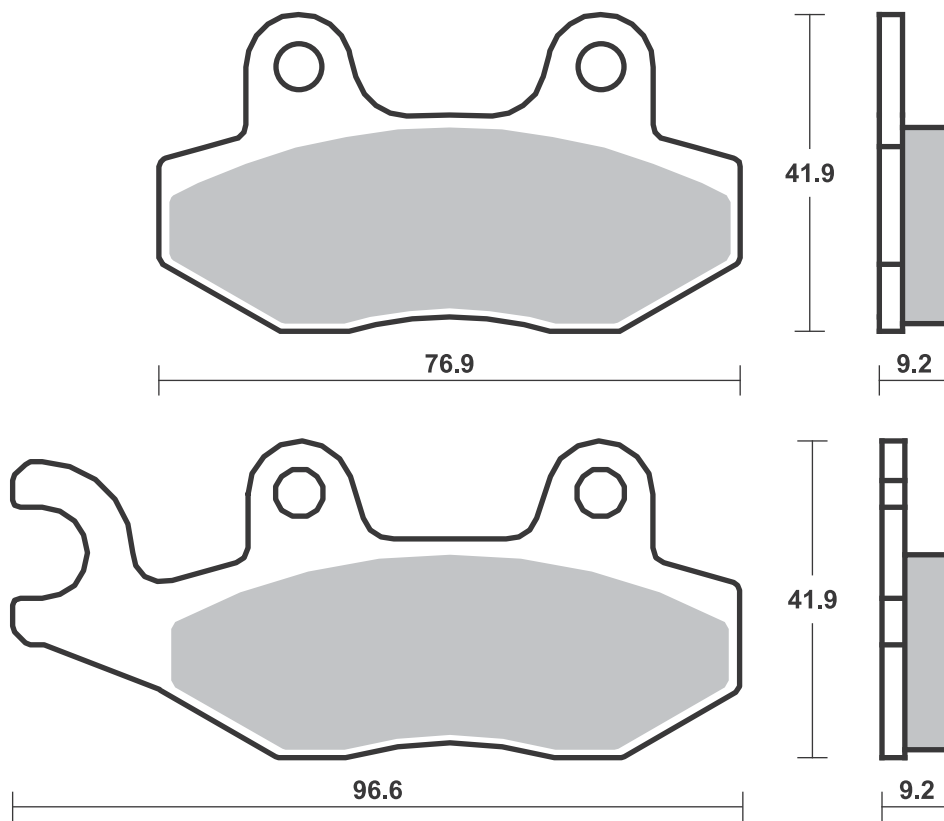
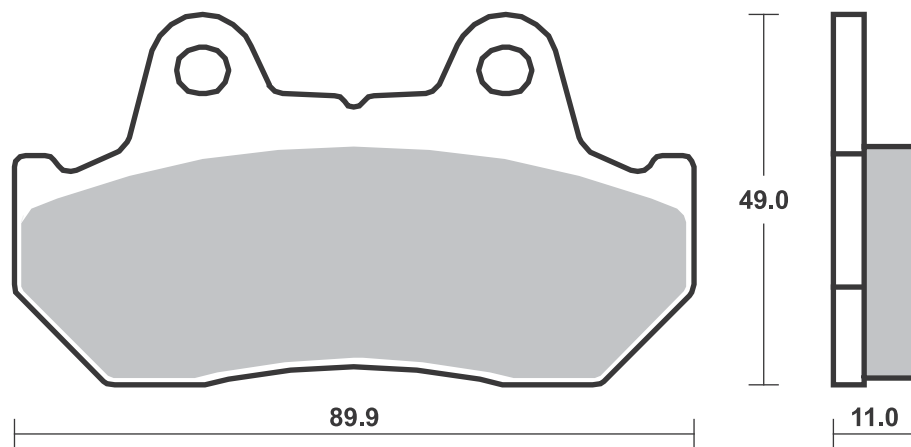





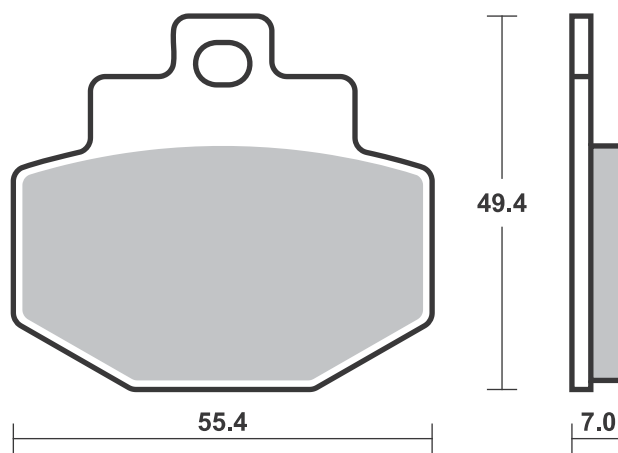
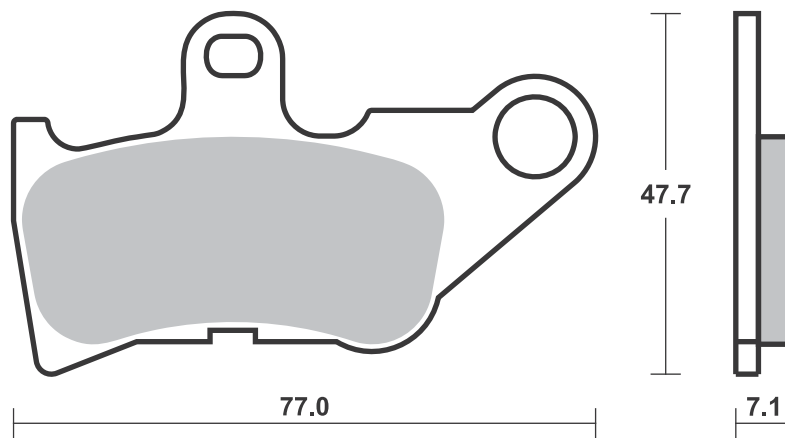
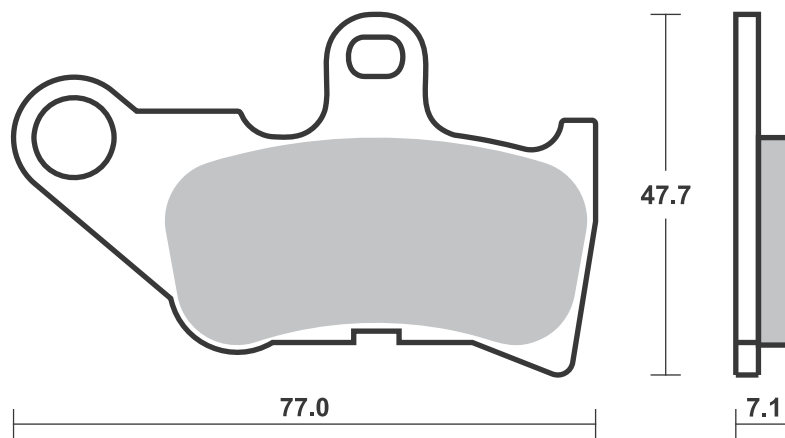



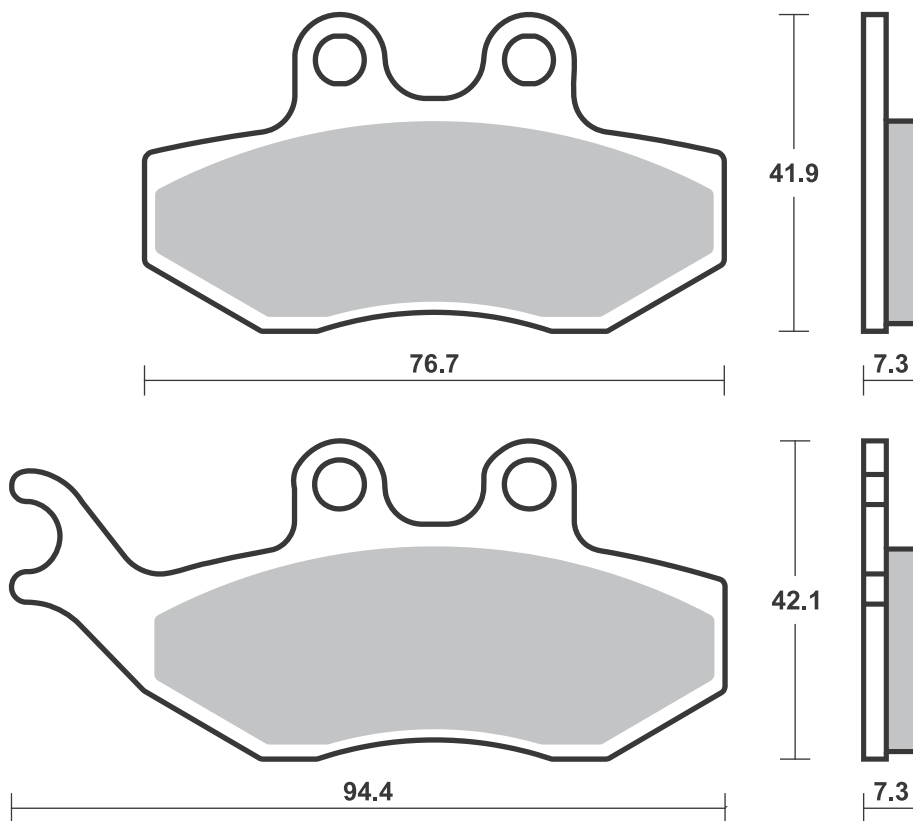
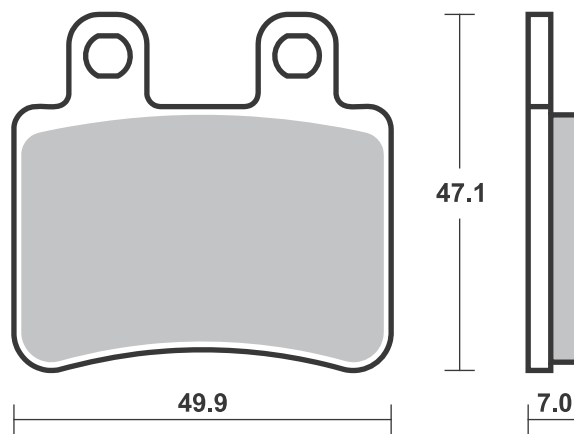





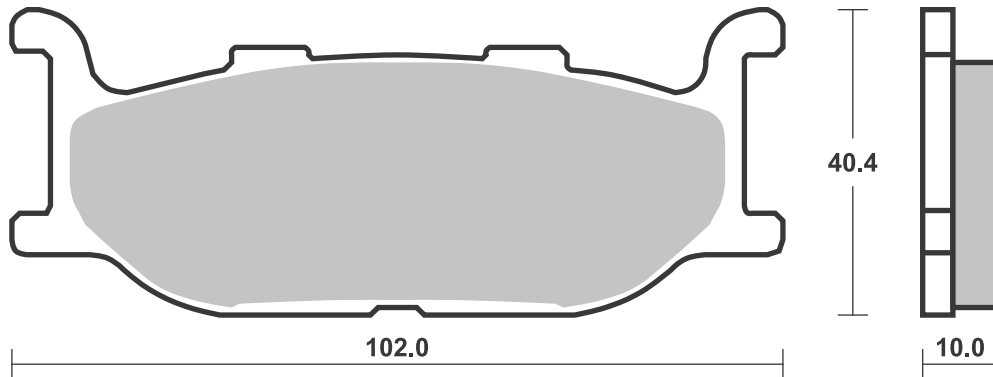
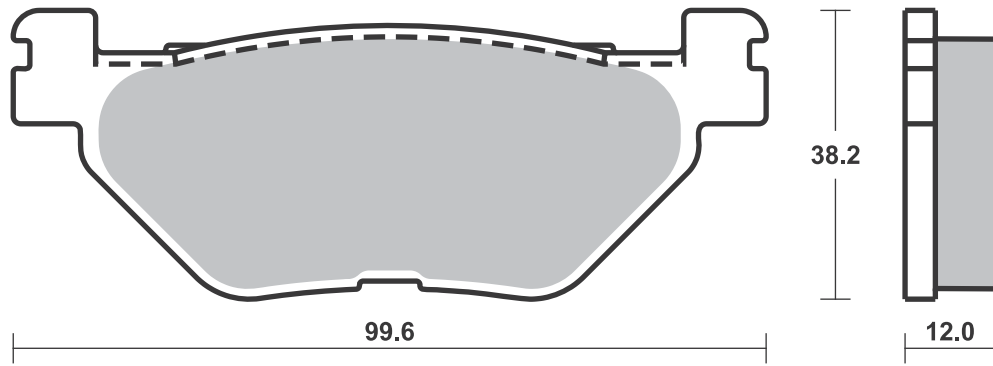

1 set = 4 pcs.

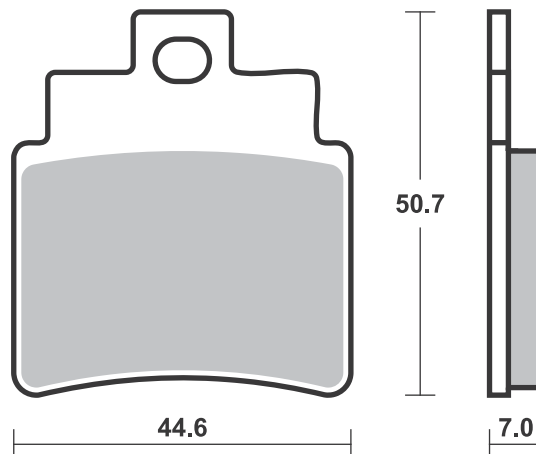

Brake Pad 1:1 Drawings,  
Compounds, Fitments



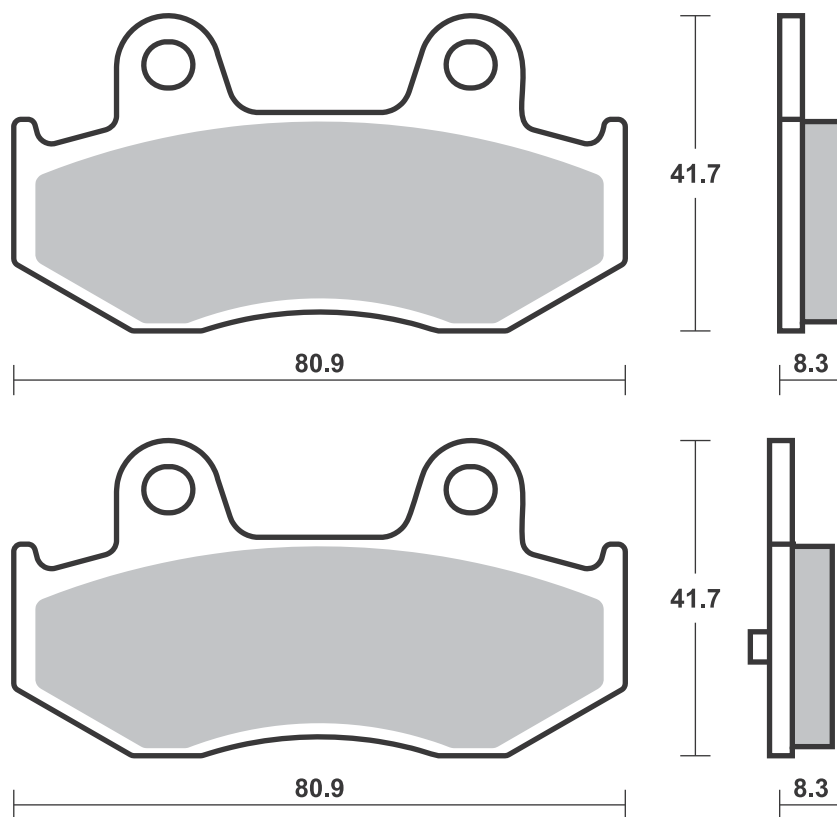
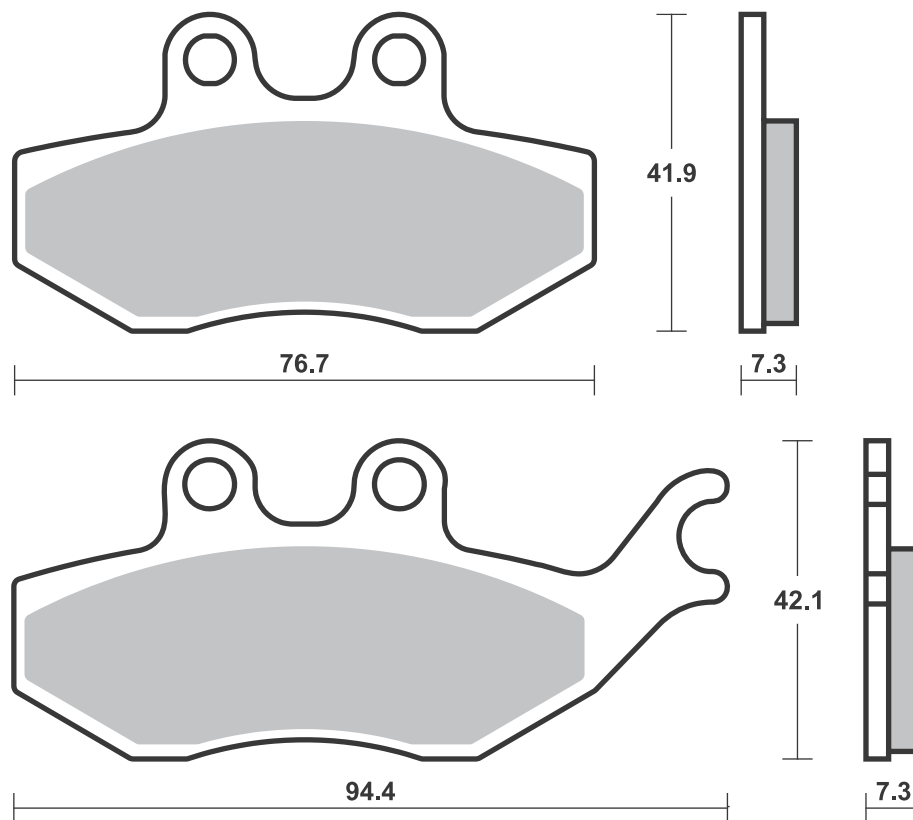



**SBS 175** Recommended compound



<b>BMW</b>			
	125 C1	00-03	<b>CT</b>
	200 C1	02-04	<b>CT</b>
<b>C</b>	400 X	18-	<b>MS</b>

<b>YAMAHA</b>			
<b>XC</b>	155 S-Max	15-18	<b>CT</b>

**SBS 176** Recommended compound



<b>BMW</b>			
	125 C1	00-03	<b>CT</b>
	200 C1	02-04	<b>CT</b>

Brake Pad 1:1 Drawings,  
Compounds, Fitments

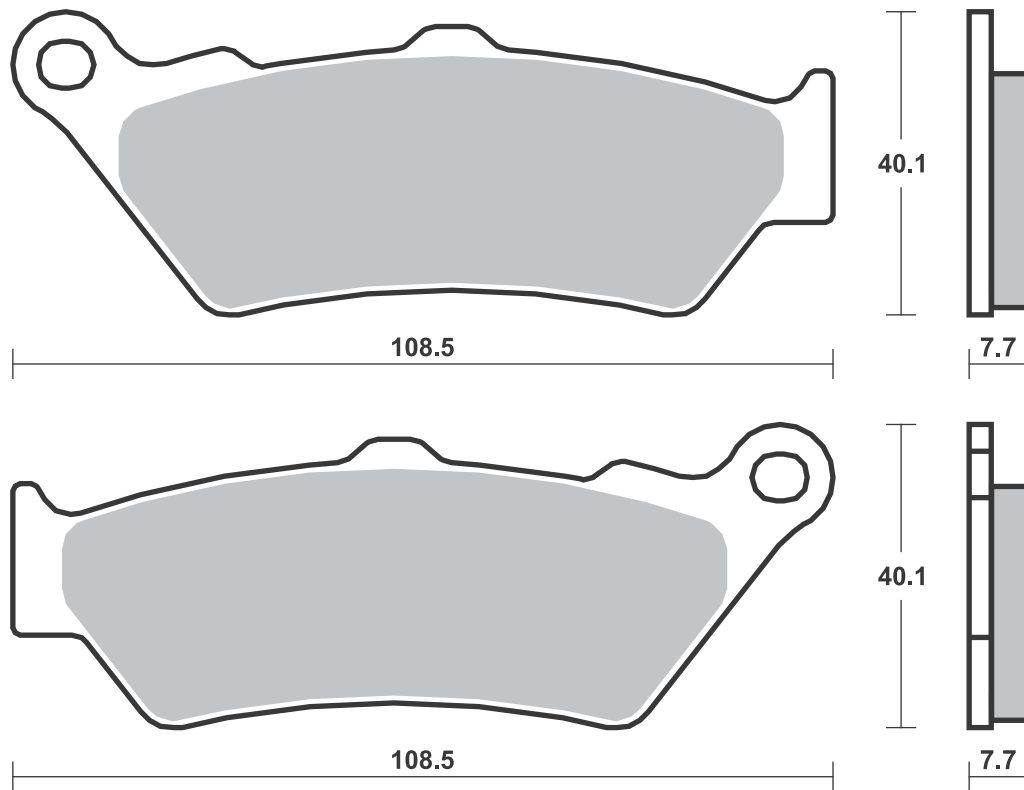
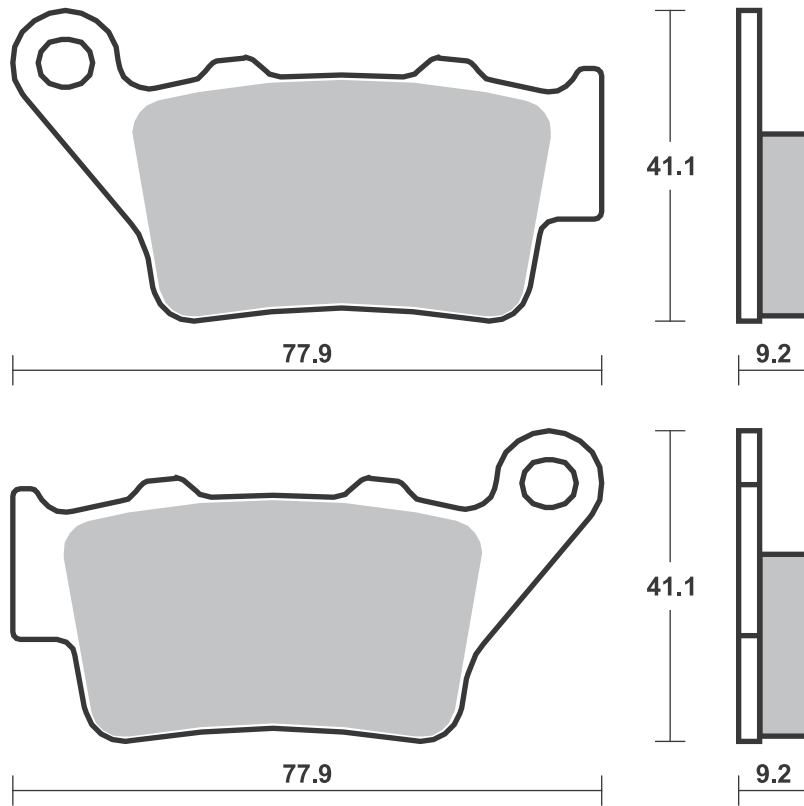



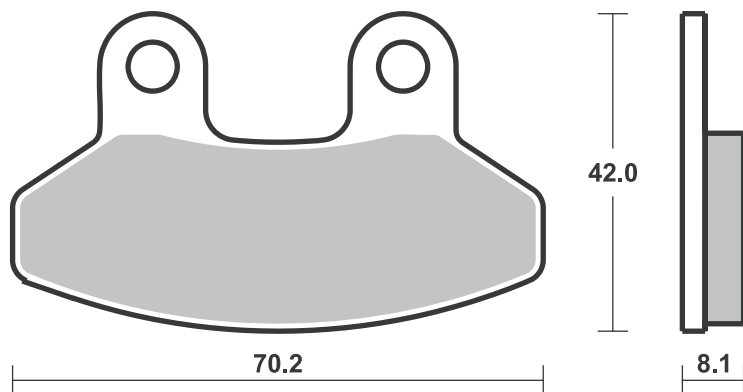
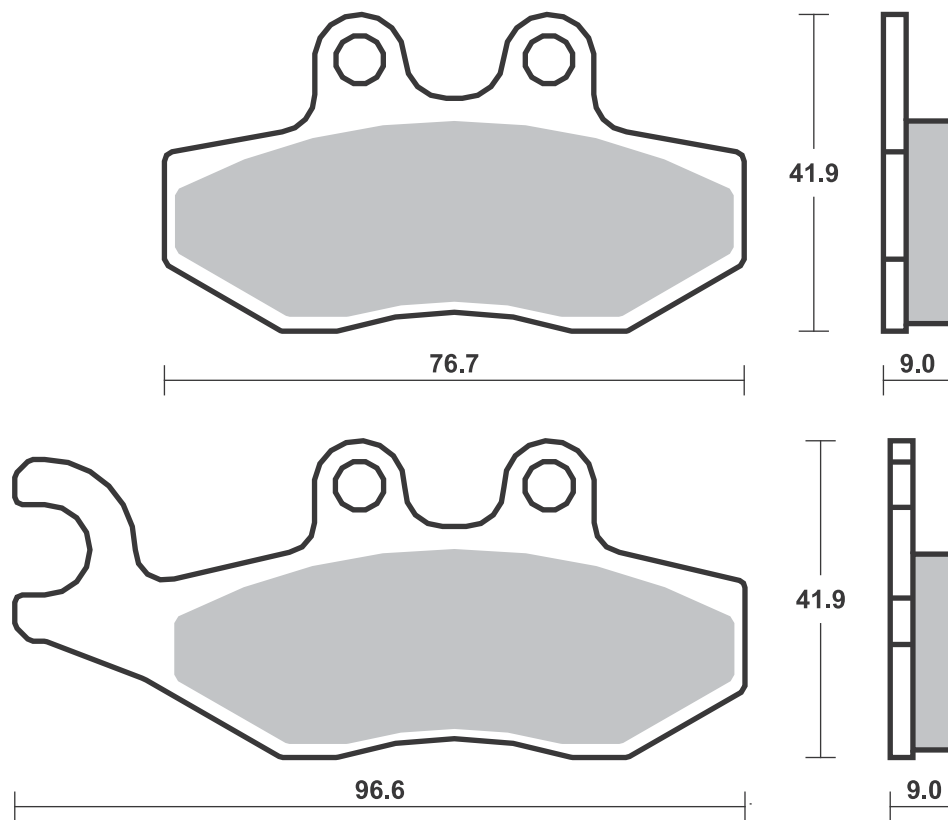





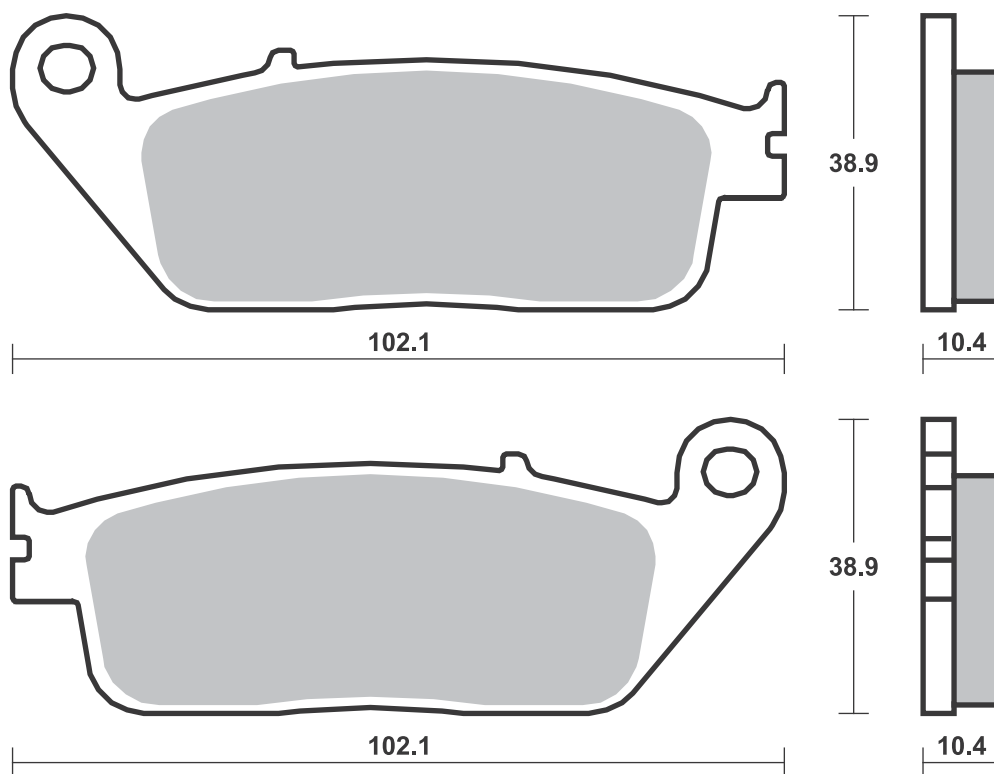
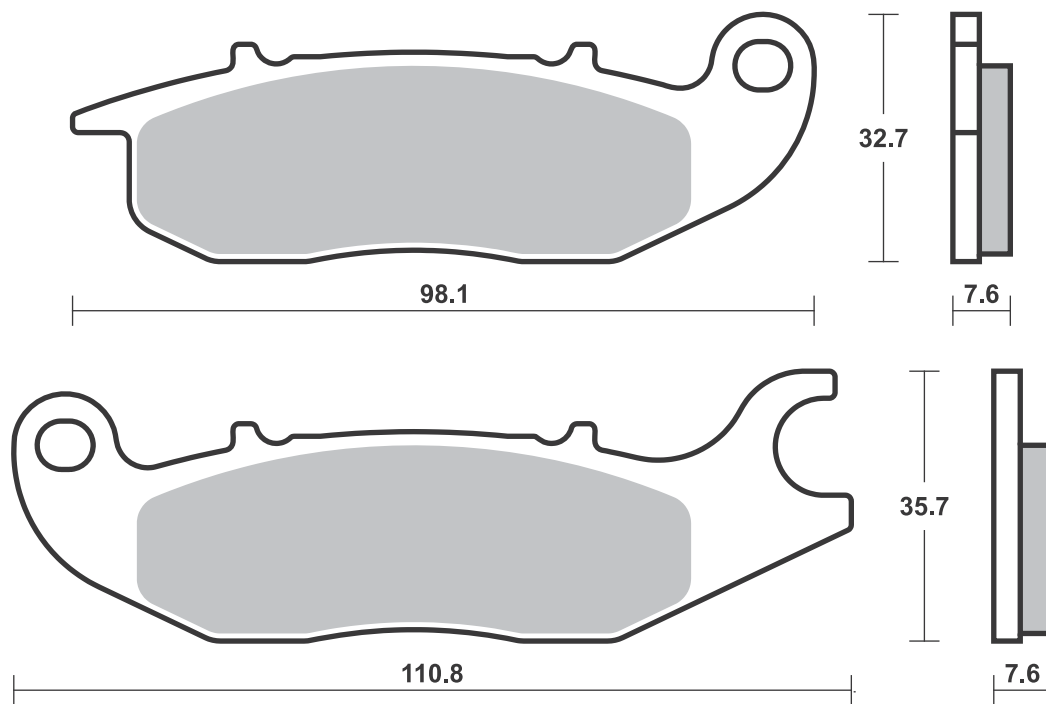



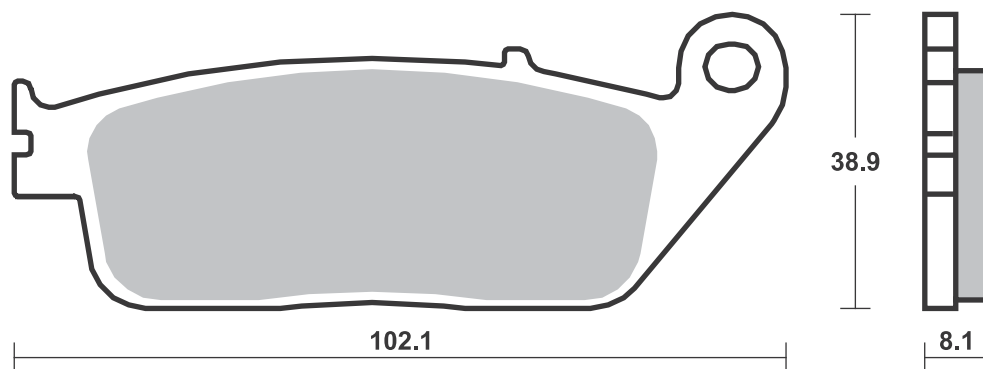
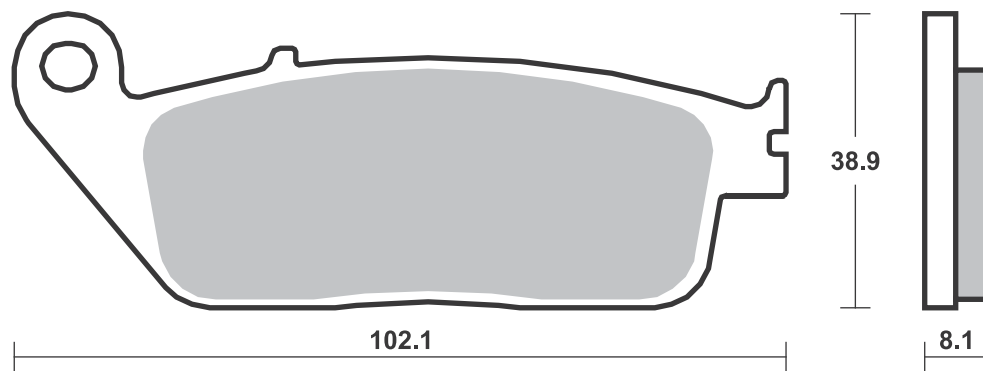
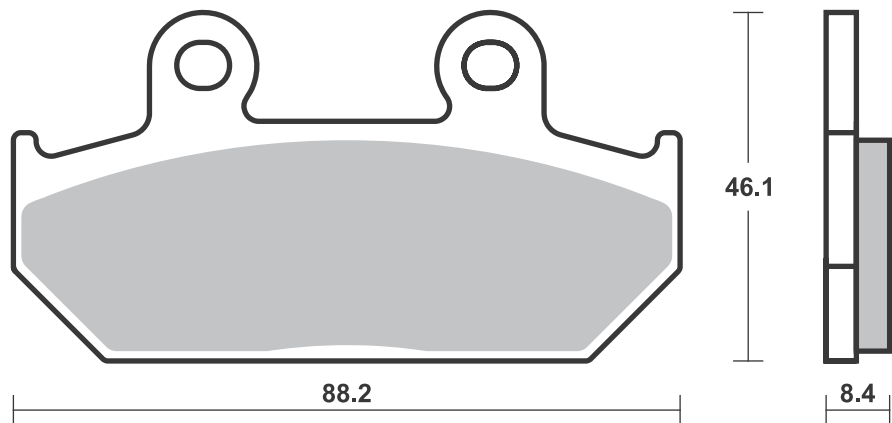
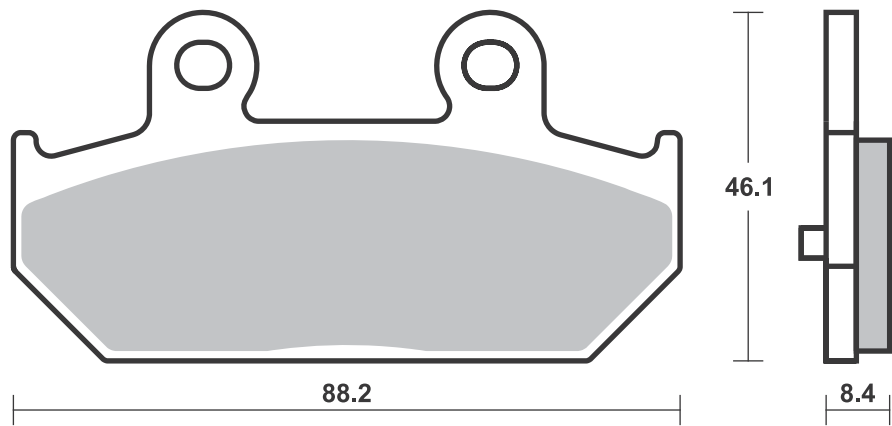





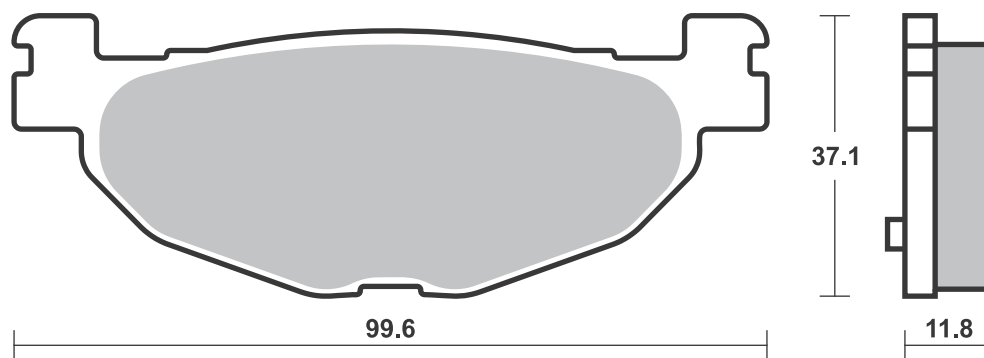
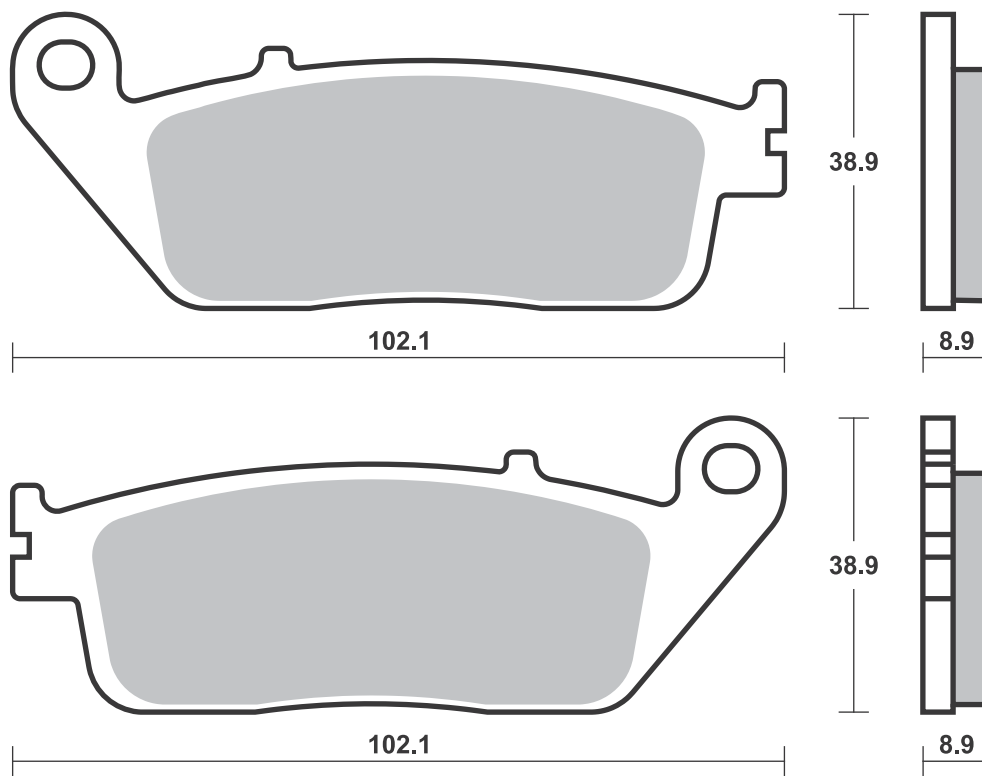

**SBS 187** Recommended compound

<b>PIAGGIO VESPA</b>		
125 Medley	16- 18	<b>CT</b>
125 Medley S	17- 18	<b>CT</b>
125 MP3 Efi	08- 11	<b>CT</b>
125 MP3 Hybrid	09- 12	<b>CT</b>
125 MP3 Yourban	11- 12	<b>CT</b>
150 Medley	16- 18	<b>CT</b>
250 MP3 Efi	08- 09	<b>MS</b>
250 MP3 LT iE	09	<b>MS</b>
300 MP3 Hybrid	11- 12	<b>MS</b>
300 MP3 Hybrid iE	11- 18	<b>MS</b>
300 MP3 iE	10- 18	<b>MS</b>
300 MP3 LT	13- 18	<b>MS</b>
300 MP3 LT		
Business	13- 18	<b>MS</b>
300 MP3 LT iE ABS	14- 18	<b>MS</b>
300 MP3 LT Sport		
ABS	14- 18	<b>MS</b>
300 MP3 LT		
Touring	11- 12	<b>MS</b>
300 MP3 Touring	11- 12	<b>MS</b>
300 MP3 Yourban		
iE	11- 18	<b>MS</b>
350 Beverly S	14- 18	<b>MS</b>
BV 350	12- 17	<b>MS</b>

**SBS 188** Recommended compound

<b>BETA</b>		
50 AJP Caliper		
incl. pin/spring	90- 18	<b>HF</b>
<b>CAGIVA</b>		
50 AJP Caliper		
incl. pin/spring	90- 18	<b>HF</b>
<b>DERBI</b>		
50 AJP Caliper		
incl. pin/spring	90- 18	<b>HF</b>
<b>ITALJET</b>		
50 AJP Caliper		
incl. pin/spring	90- 18	<b>HF</b>
<b>SHERCO</b>		
50 AJP Caliper		
incl. pin/spring	91- 18	<b>HF</b>
<b>YAMAHA</b>		
50 AJP Caliper		
incl. pin/spring	91- 18	<b>HF</b>

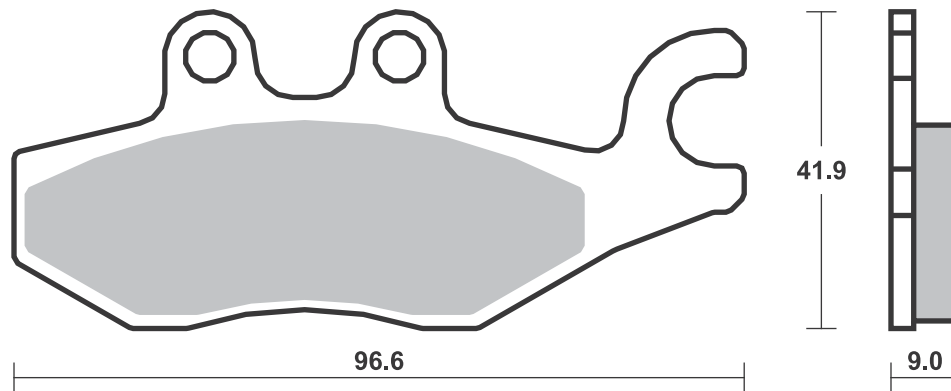
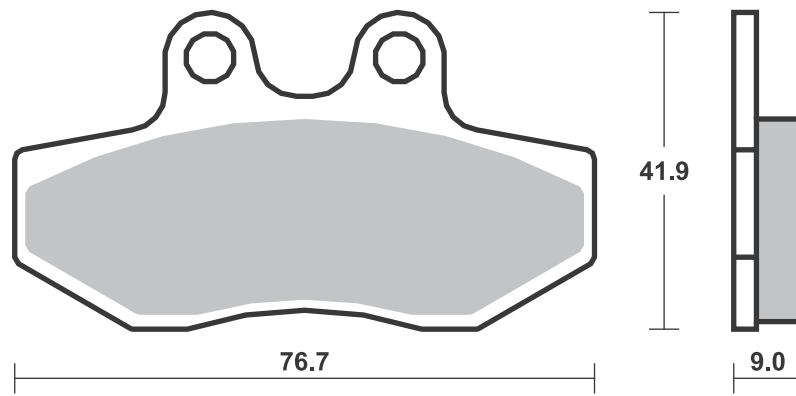

*If required without springs - see SBS 105*

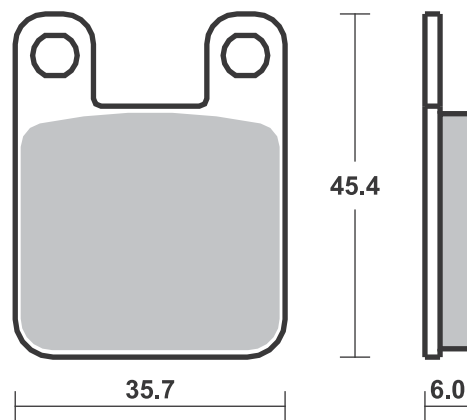



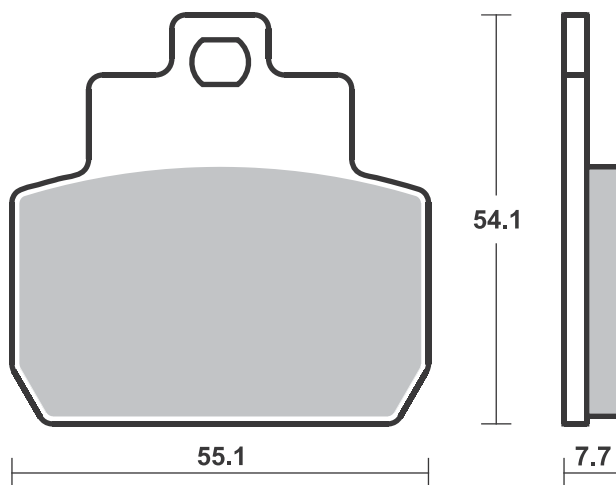
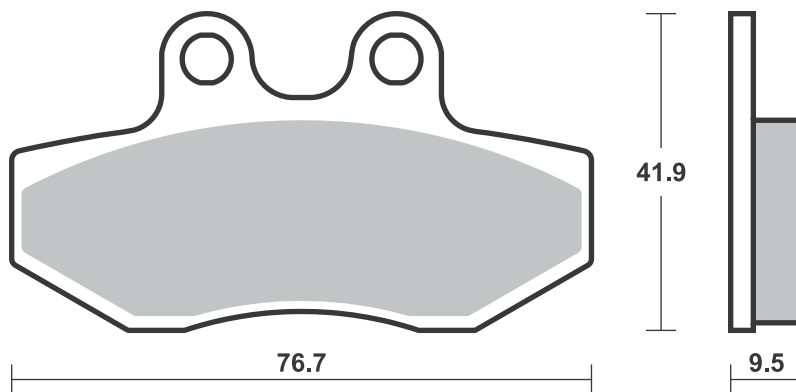
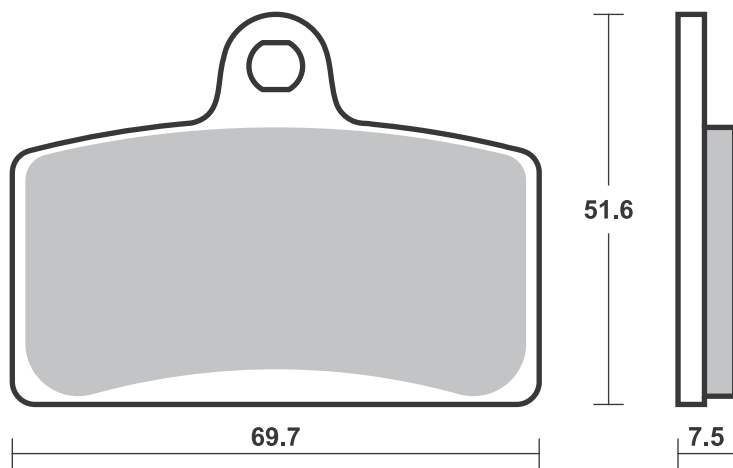



**SBS 192** Recommended compound



<b>HONDA</b>			
SH	125 i	09-12	<b>HF</b>
SH	150 i	09-12	<b>HF</b>
PS	250	05-06	<b>MS</b>
SH	300 i	07-18	<b>MS</b>
SW-T	400	09-13	<b>MS</b>
SW-T	400 ABS	09-14	<b>MS</b>
FSC	600 Silverwing	09-18	<b>MS</b>
SW-T	600	11-13	<b>MS</b>

<b>SUZUKI</b>			
UH	125 Burgman	07-18	<b>CT</b>
UH	200	07	<b>CT</b>
UH	200 Burgman	07-13	<b>CT</b>

**SBS 193** Recommended compound



<b>HONDA</b>			
NSS	125 Forza	15-18	<b>CT</b>
SH	125	13-18	<b>HF</b>
SH	125 i	09-12	<b>HF</b>
SH	150	13-18	<b>HF</b>
SH	150 i	09-12	<b>HF</b>
SH	300 i	07-18	<b>HF</b>
SH	300 i SH30	15-18	<b>MS</b>

Brake Pad 1:1 Drawings,  
Compounds, Fitments

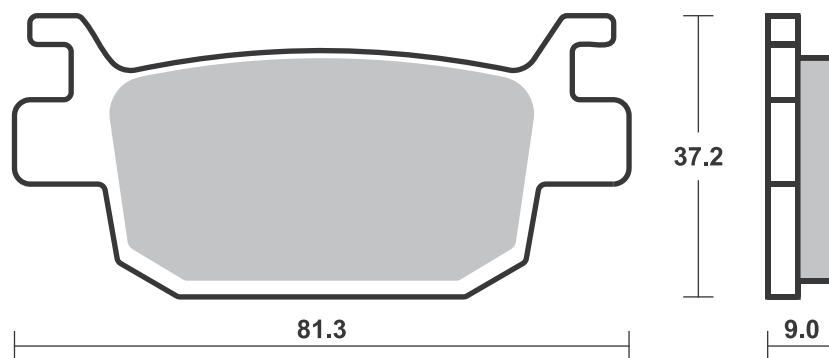
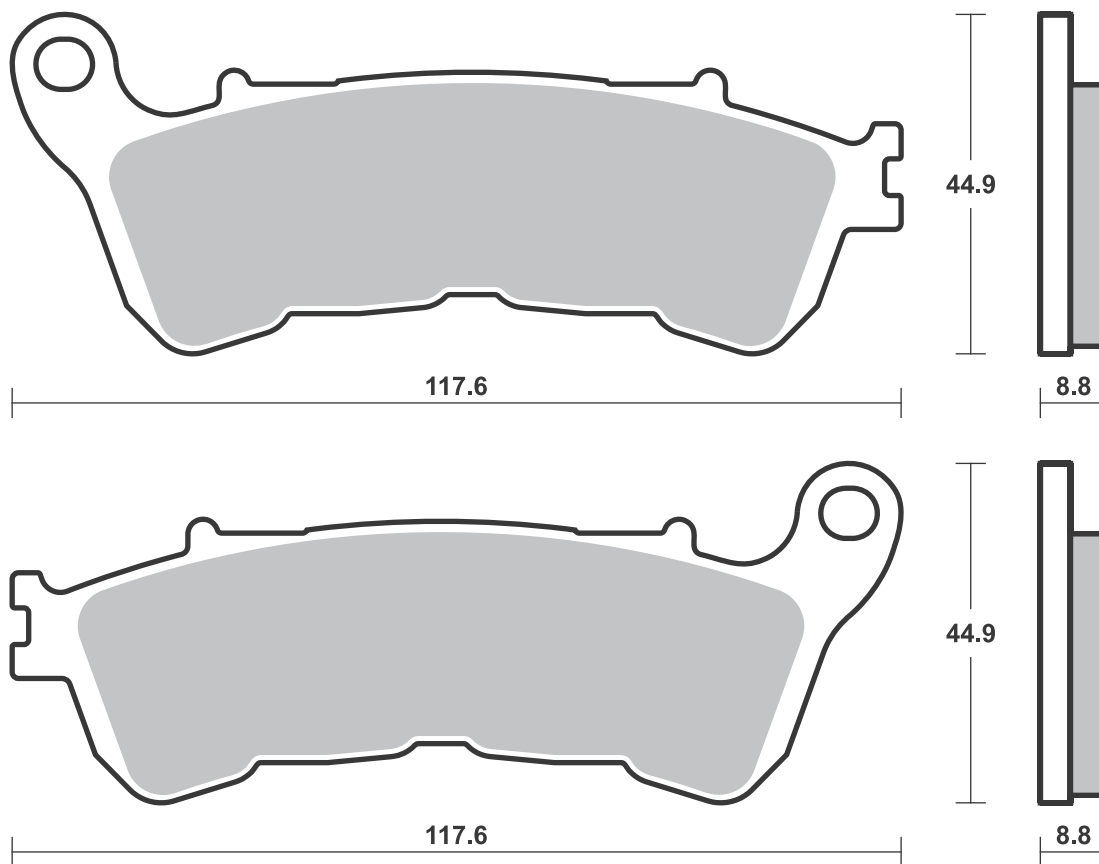



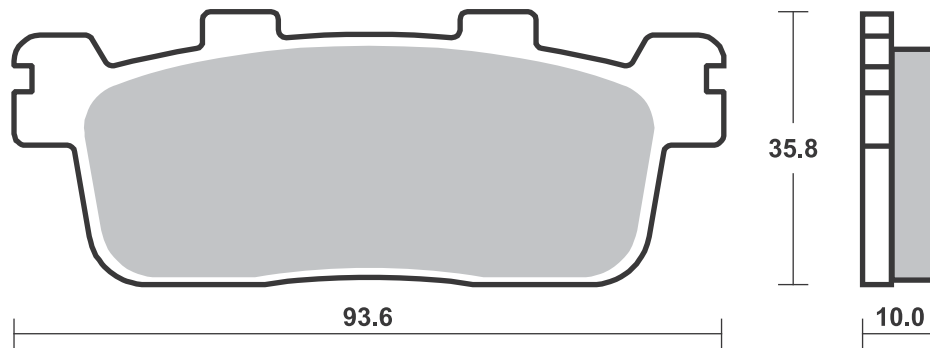
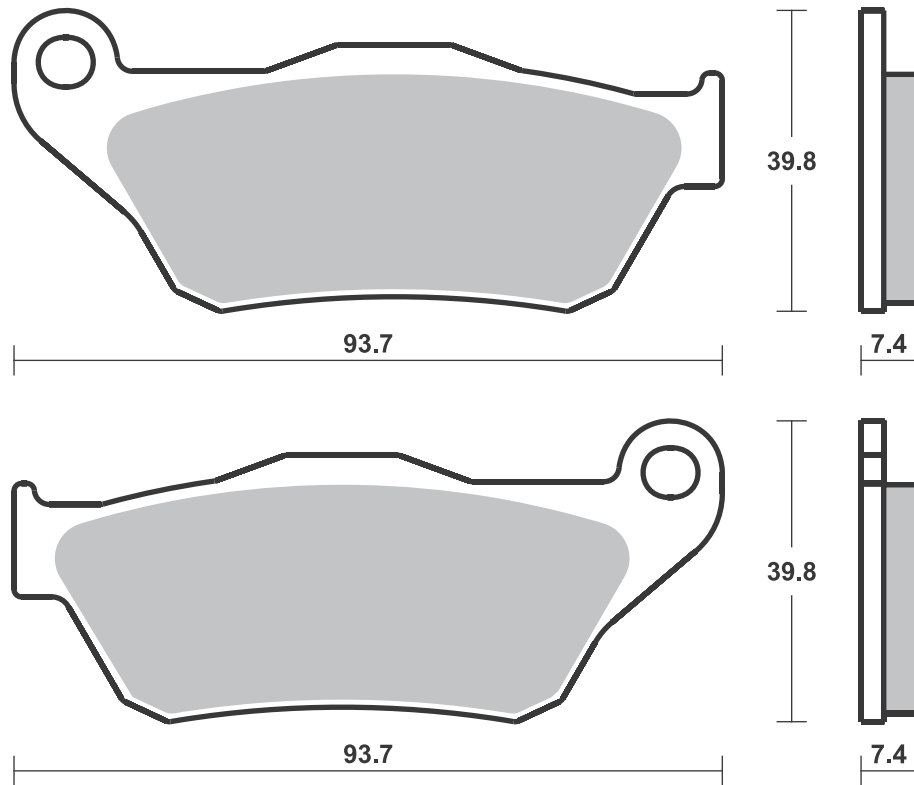





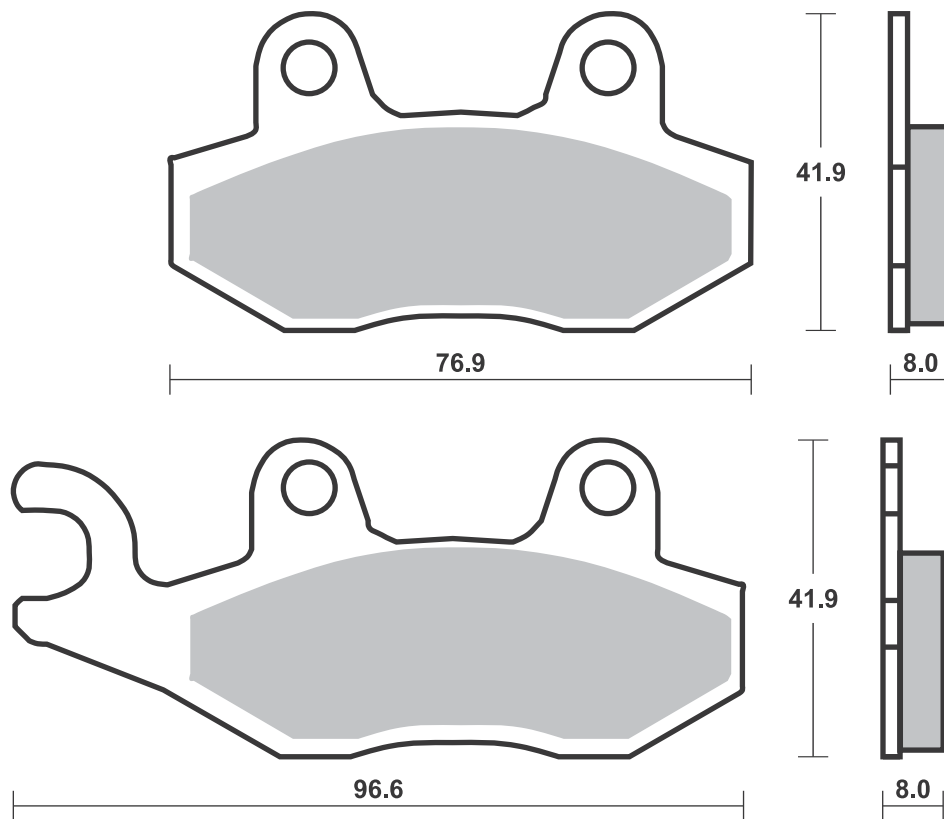
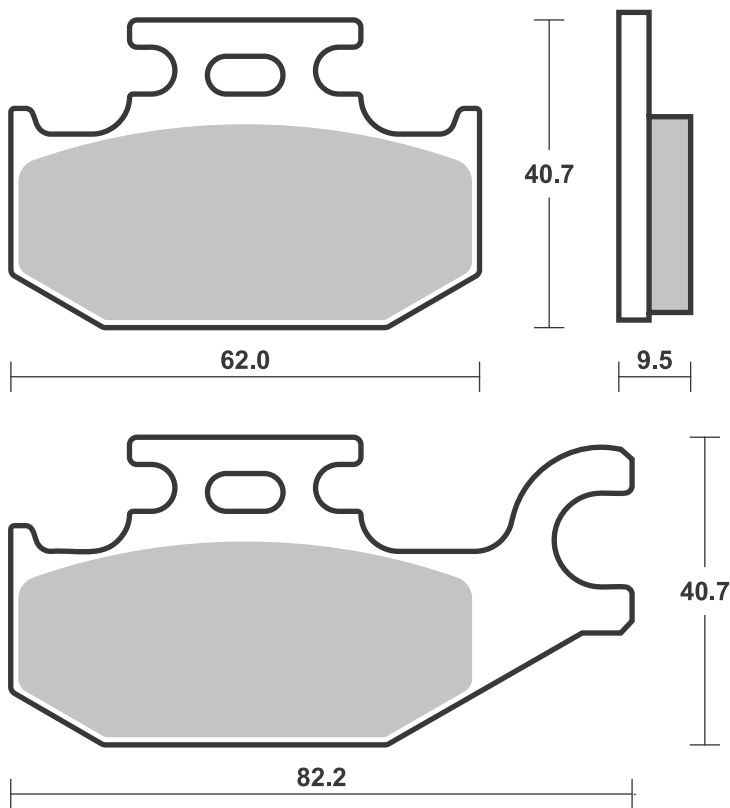



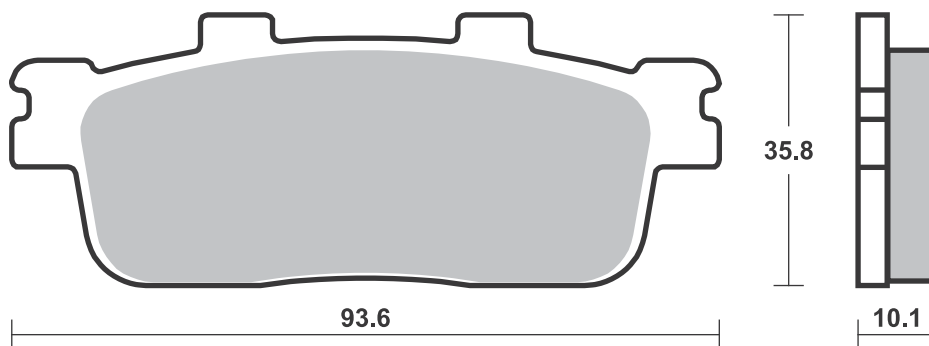
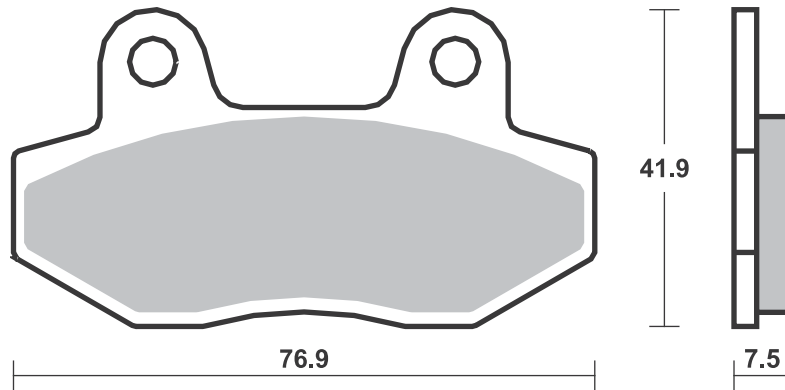
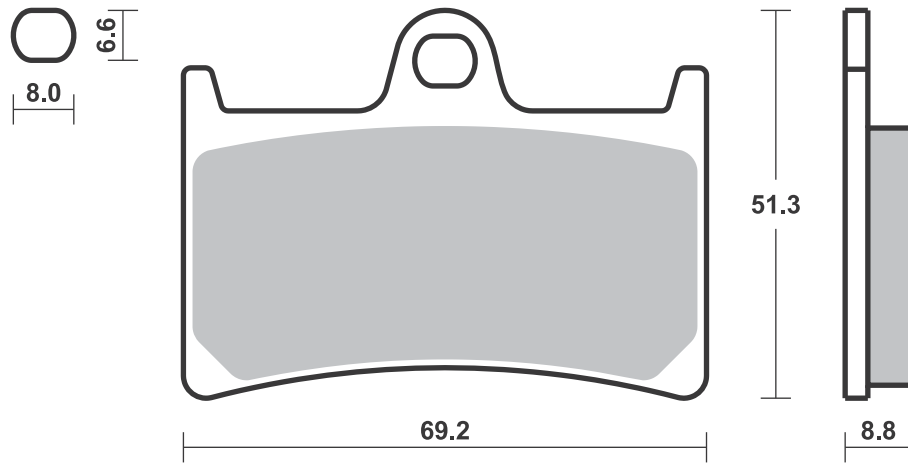



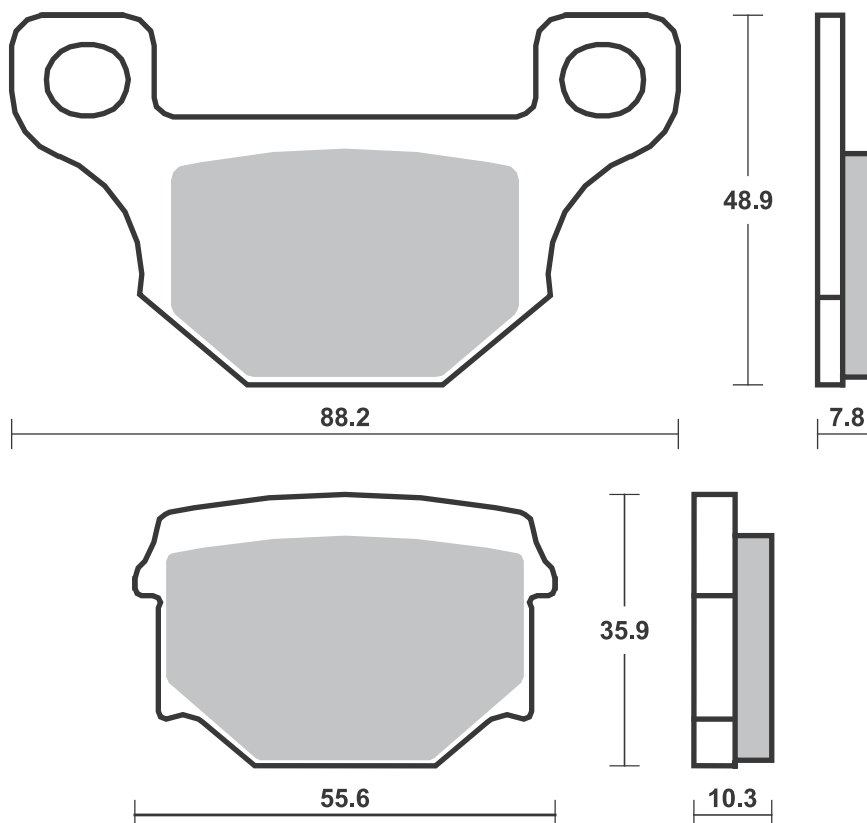
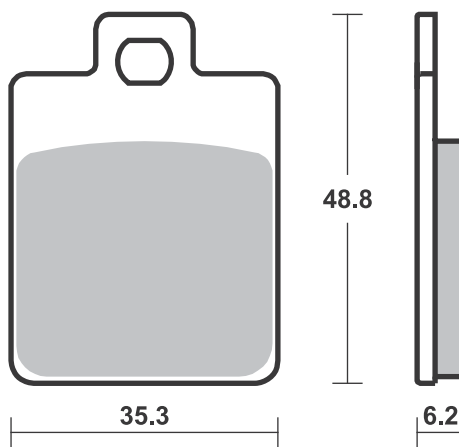





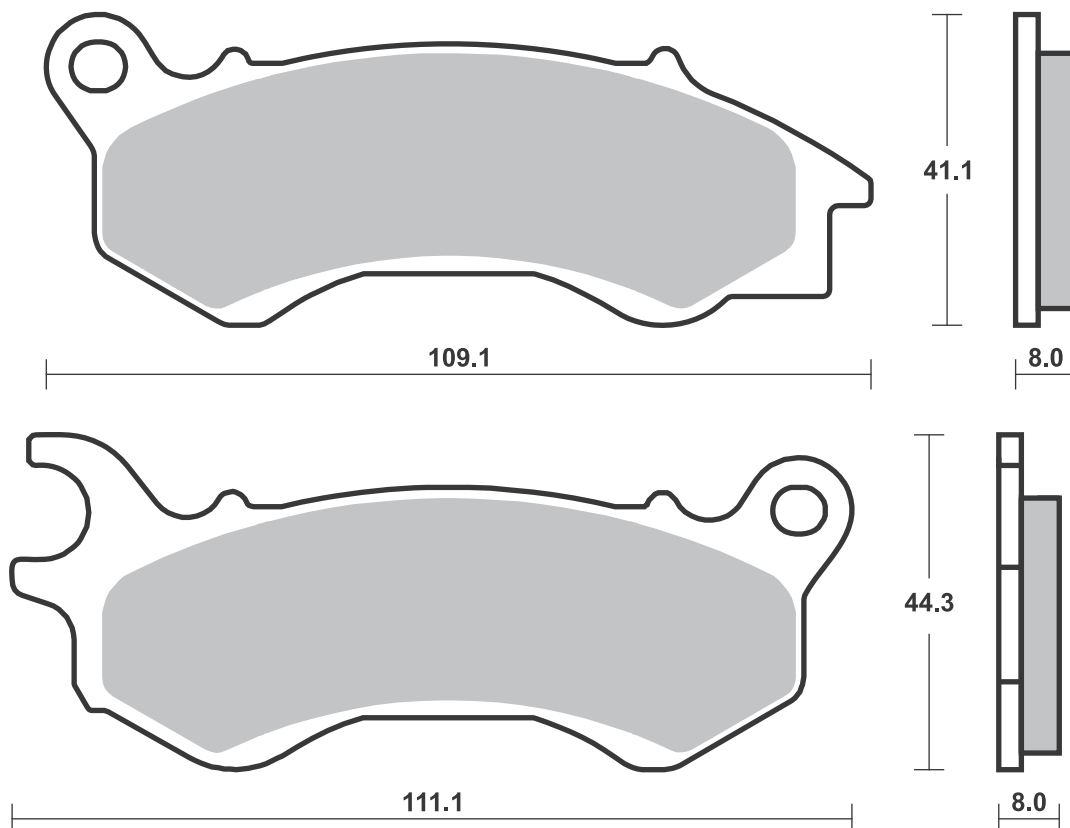
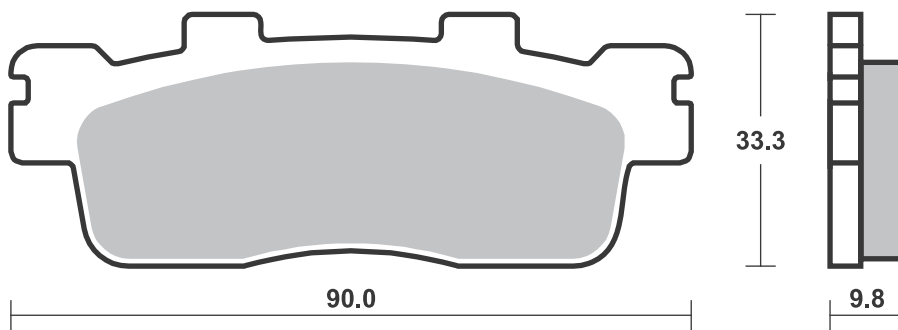



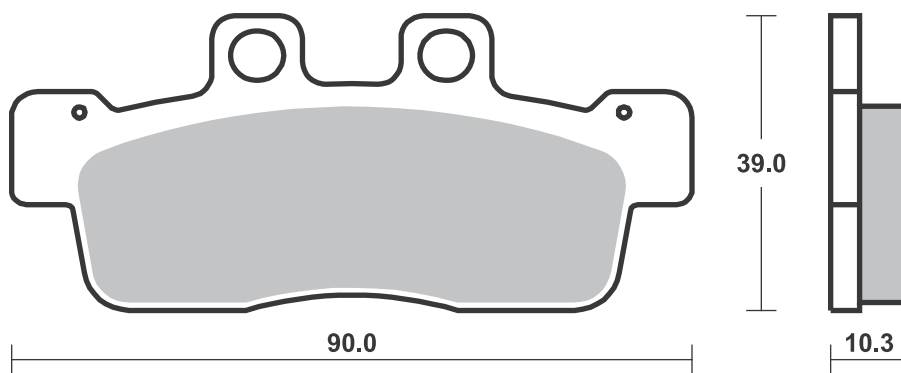
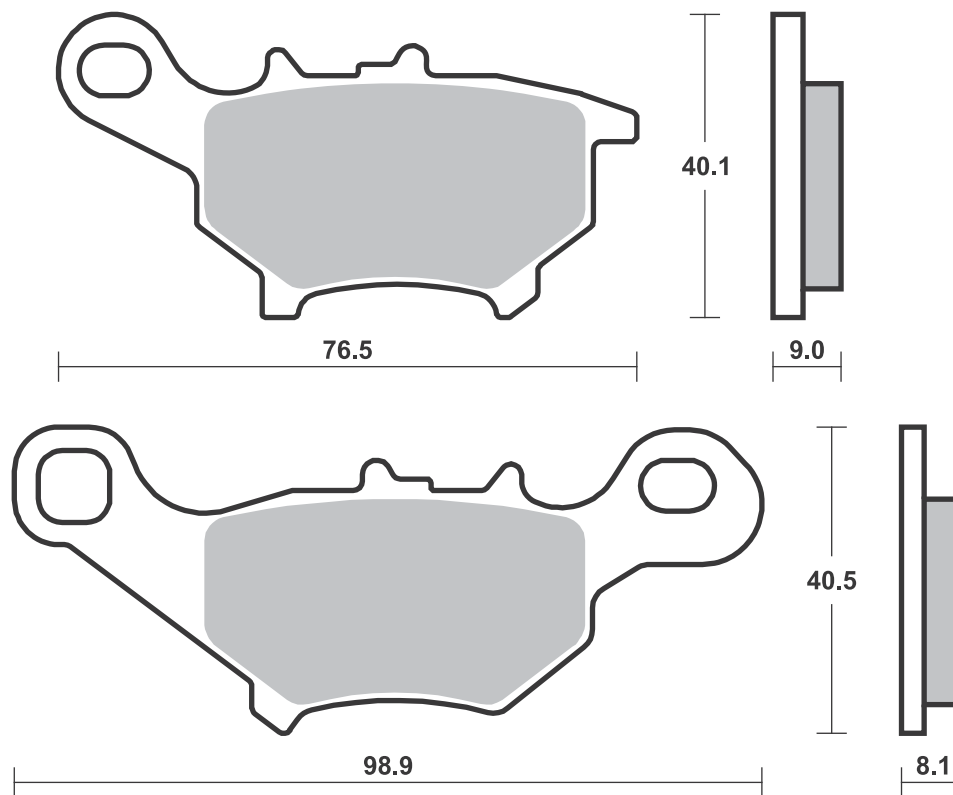





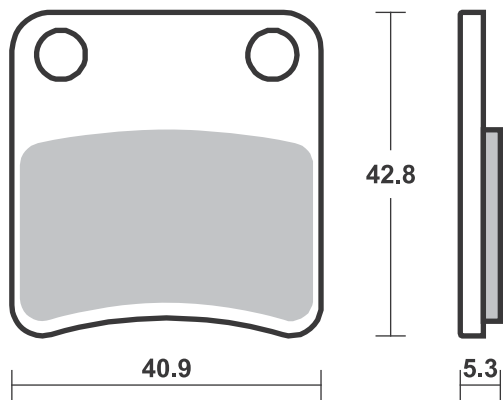
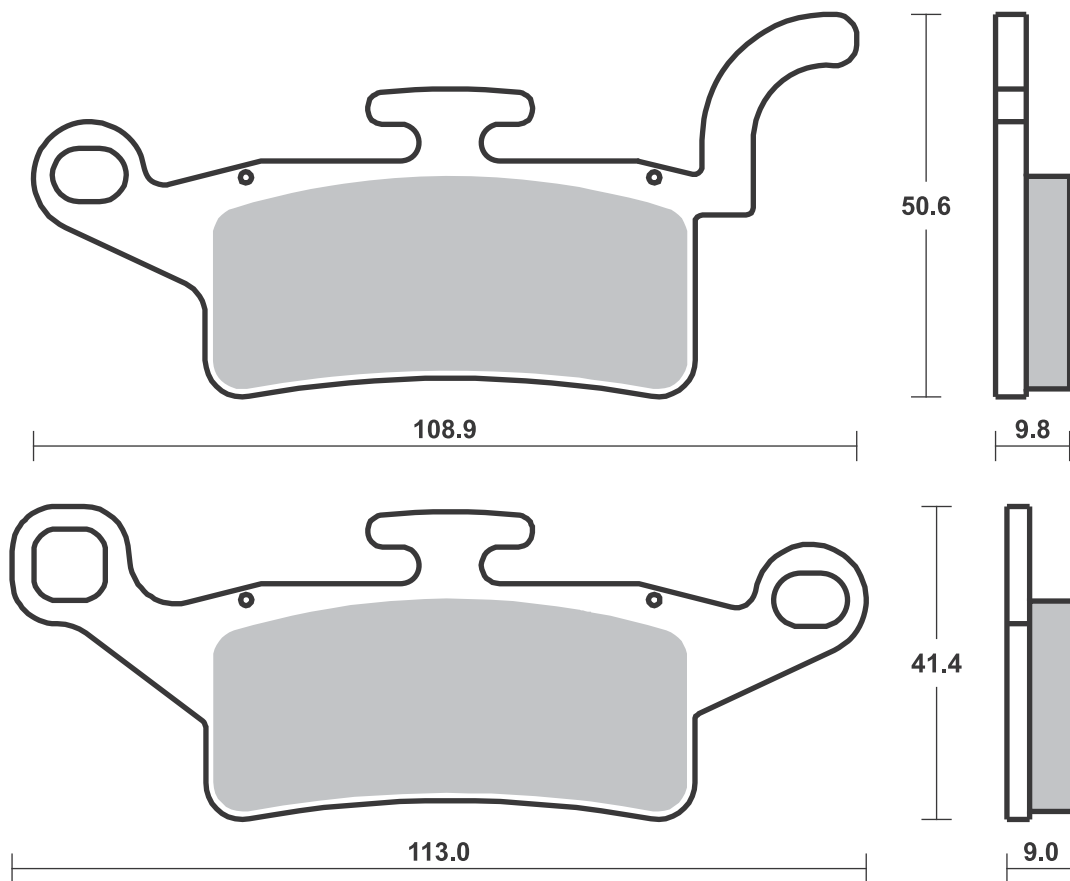



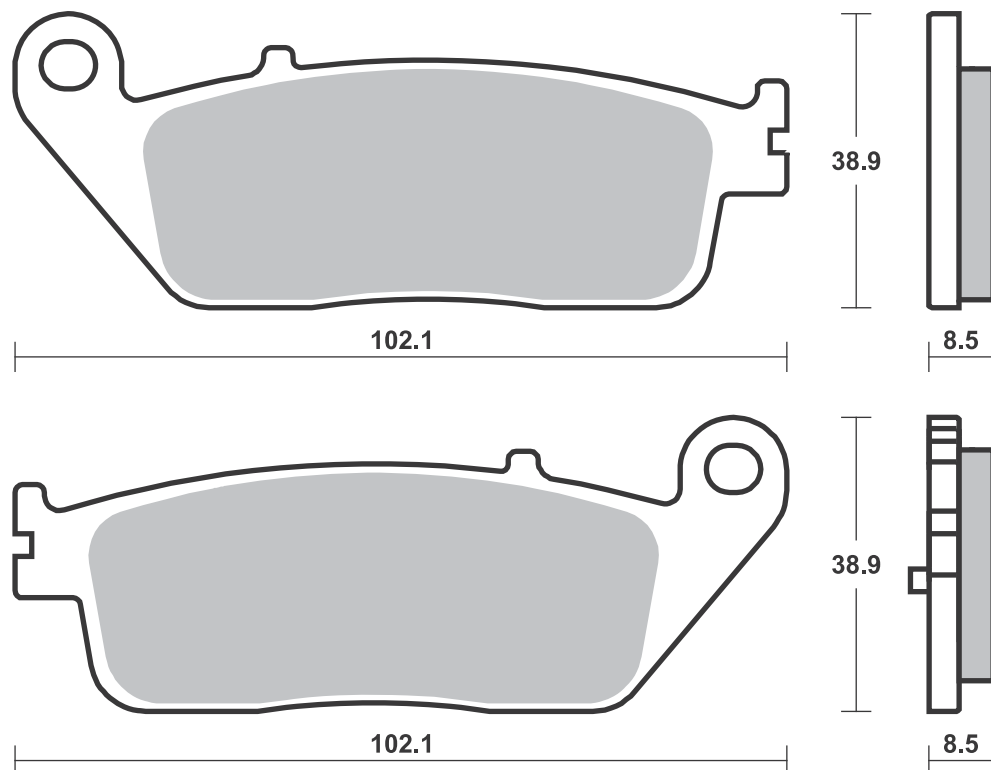
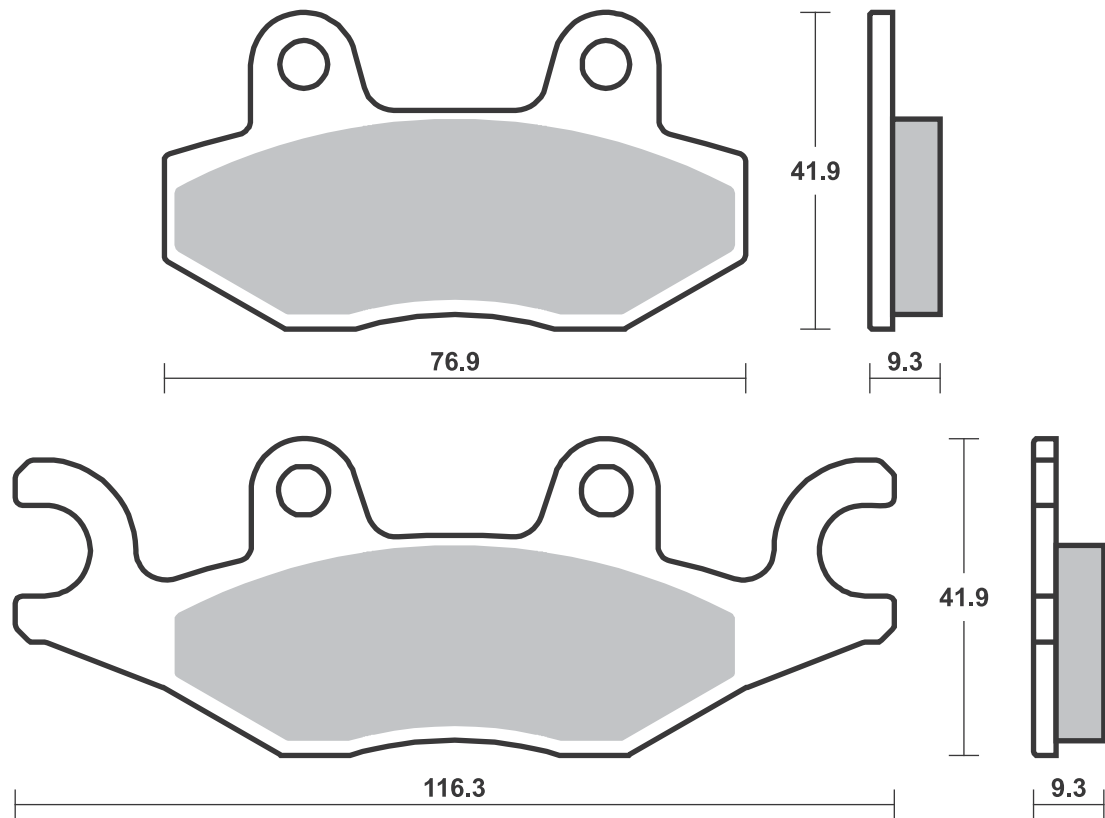



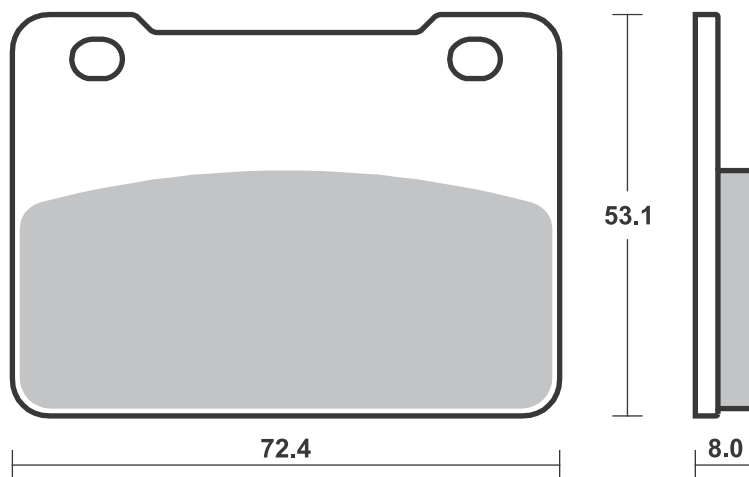
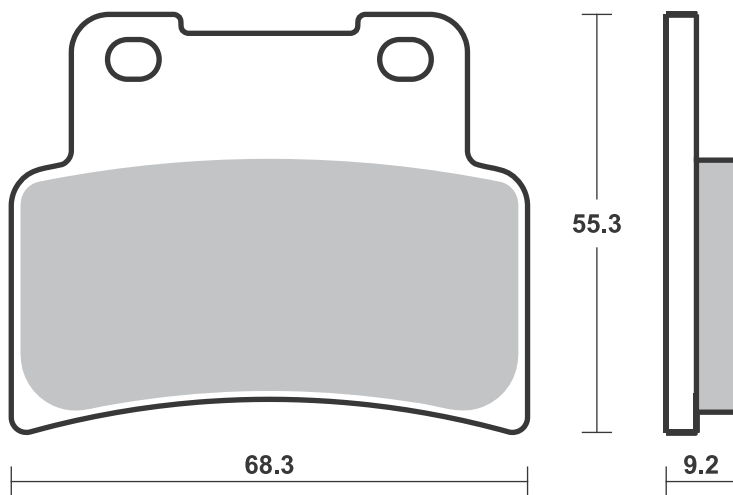





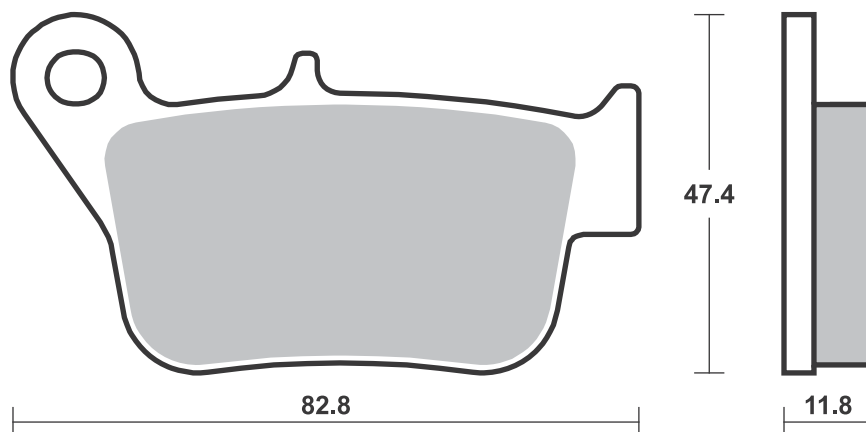
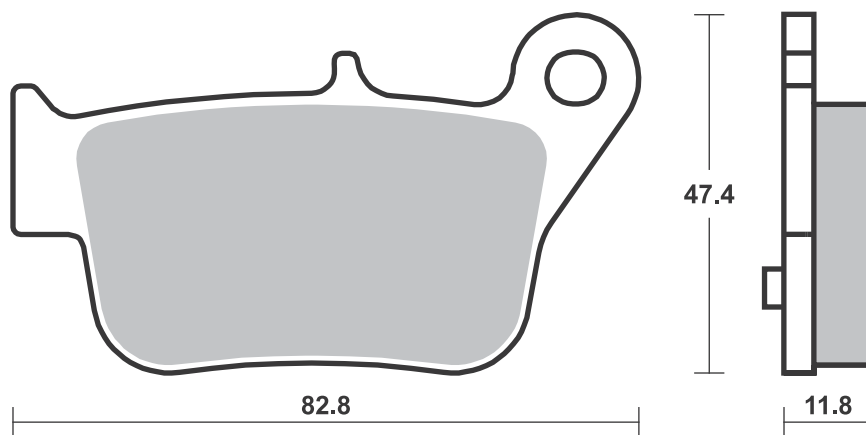
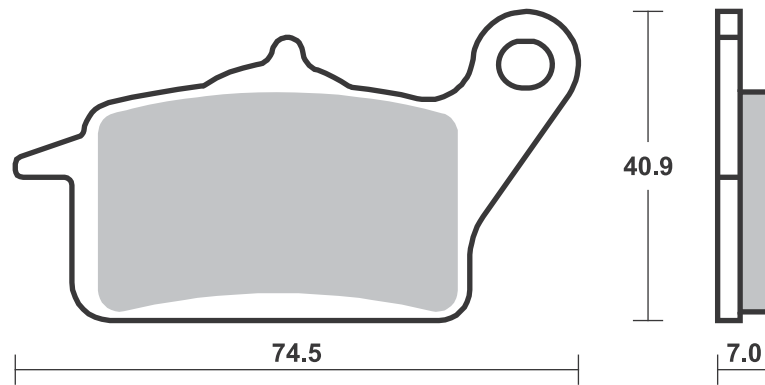
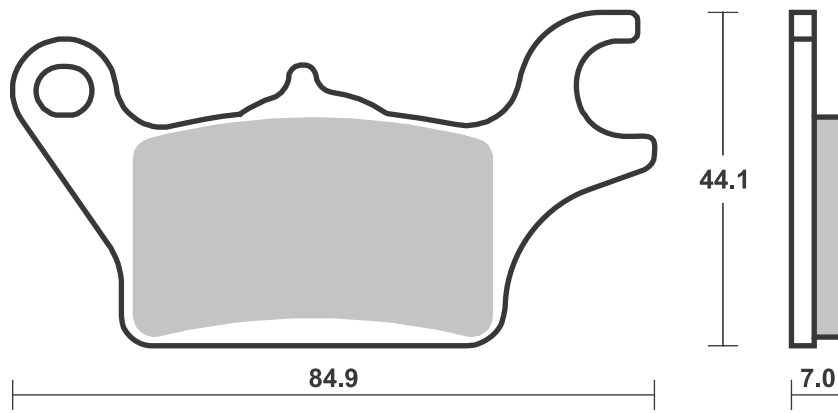



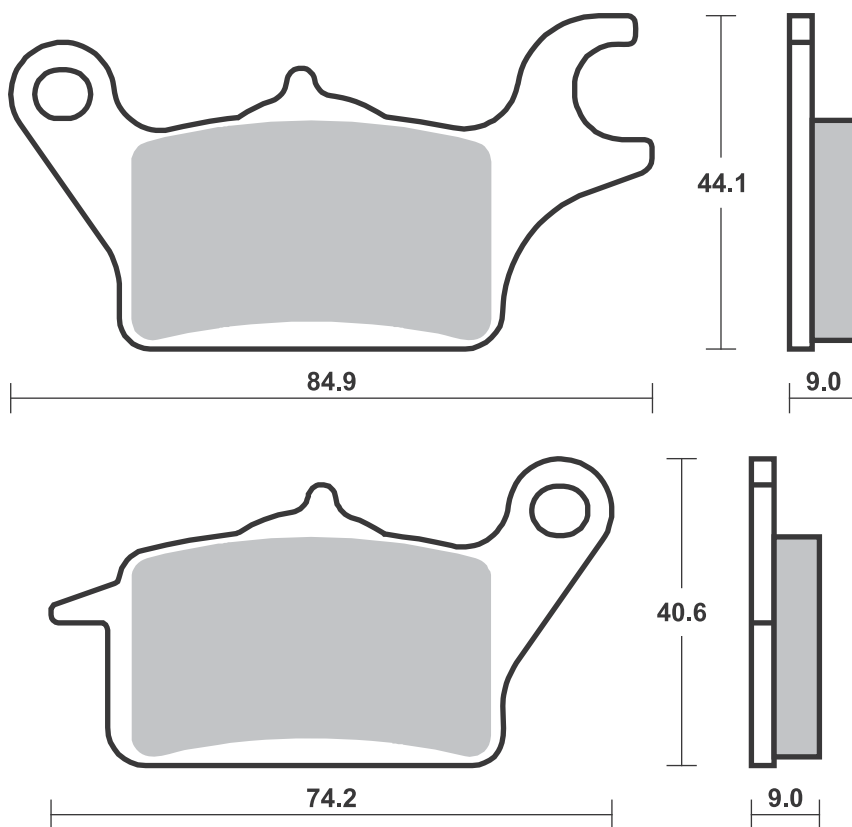
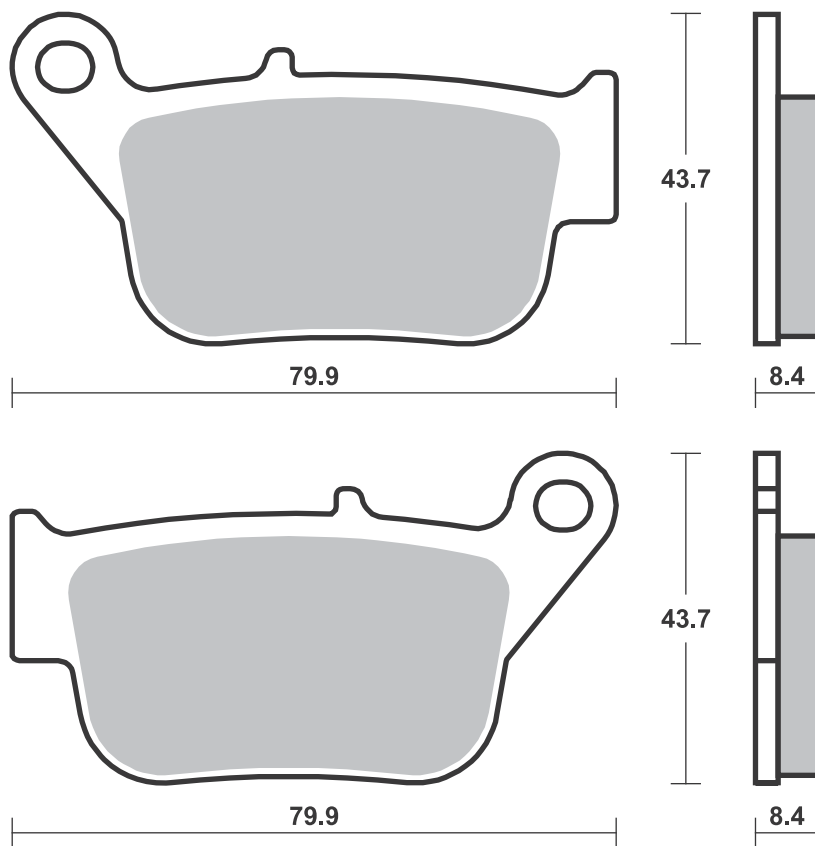





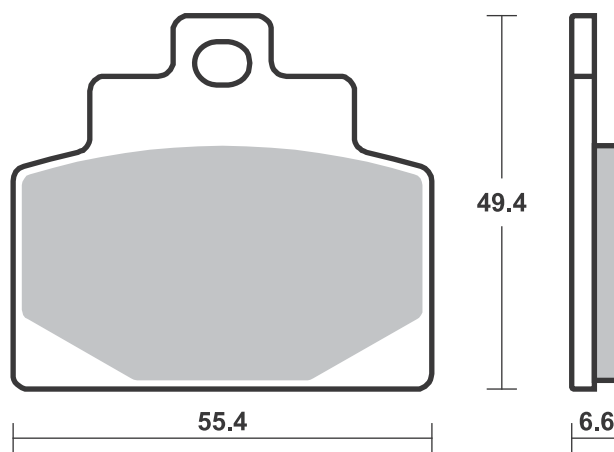
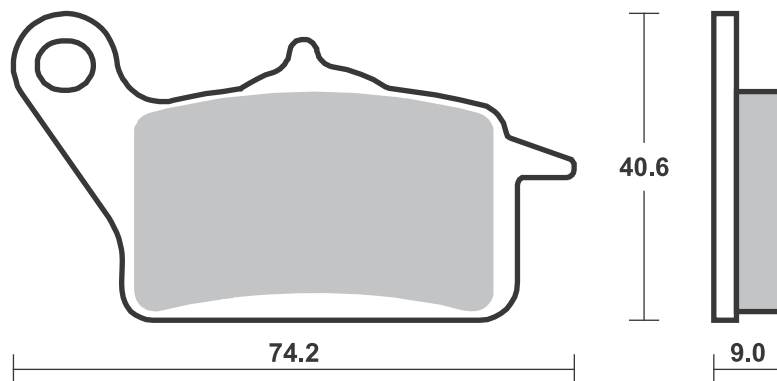
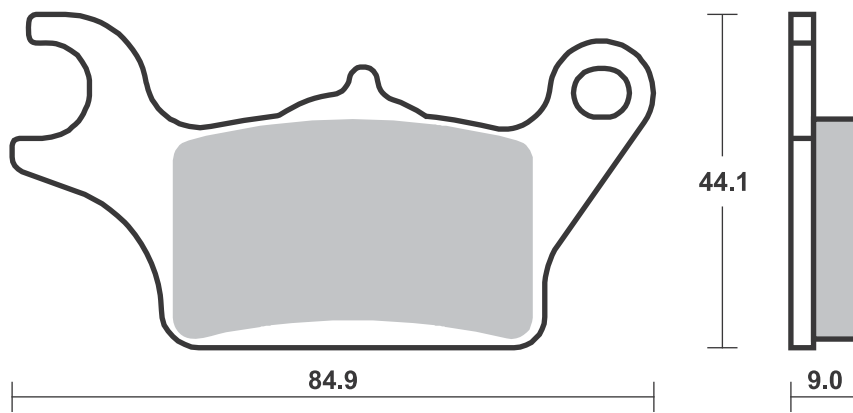



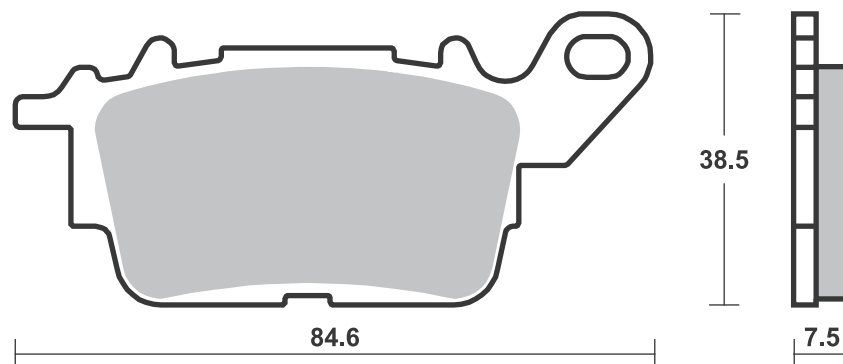
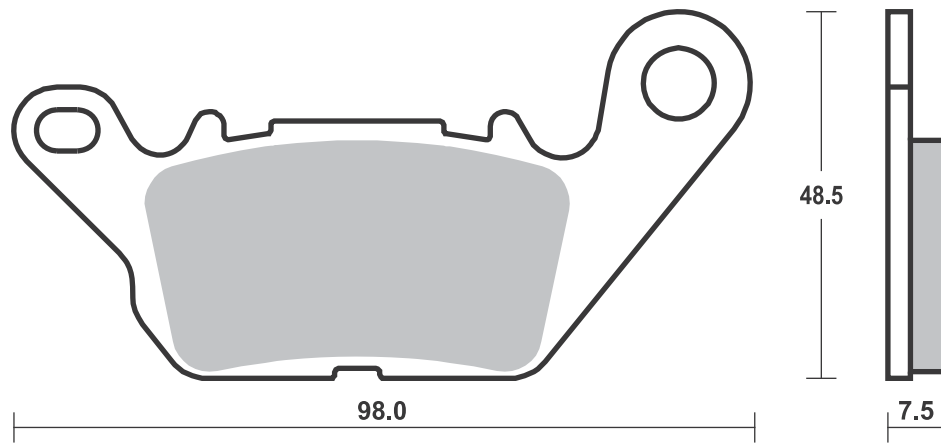
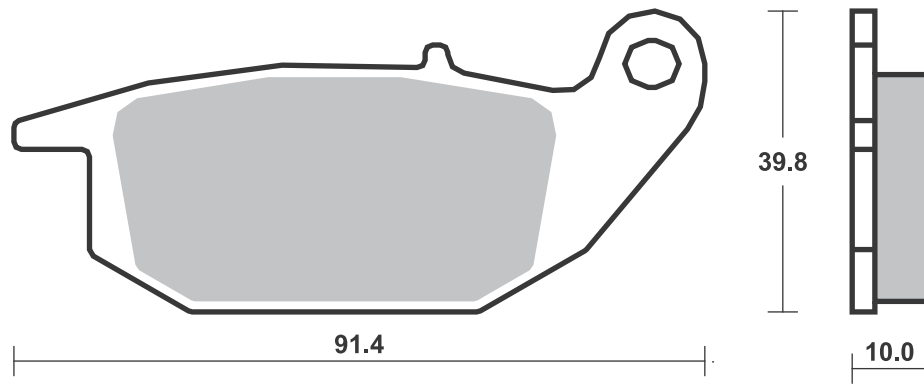
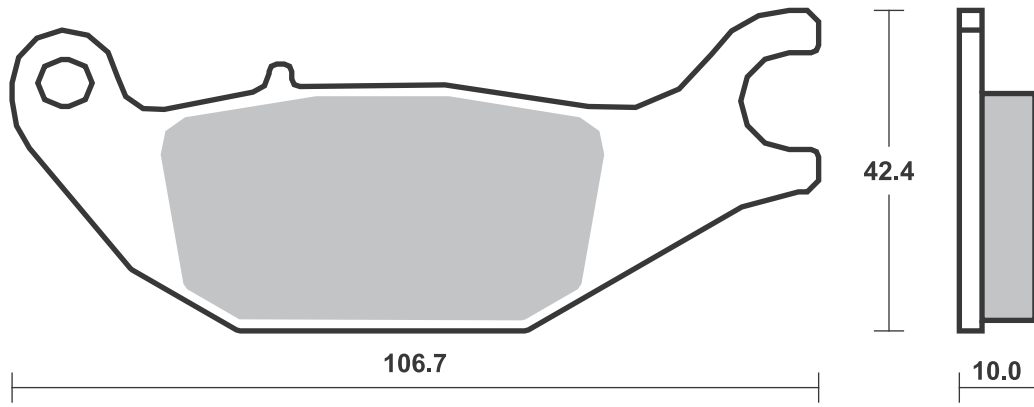



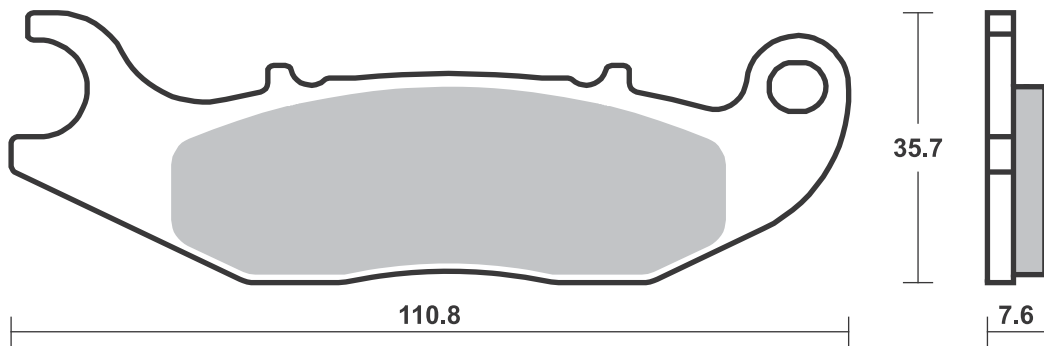
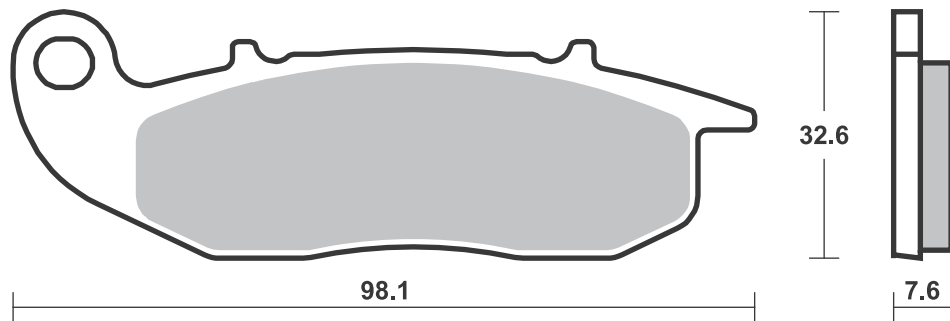
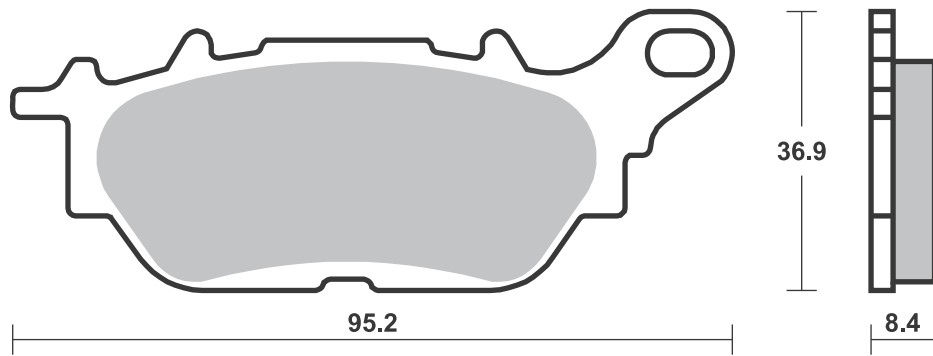
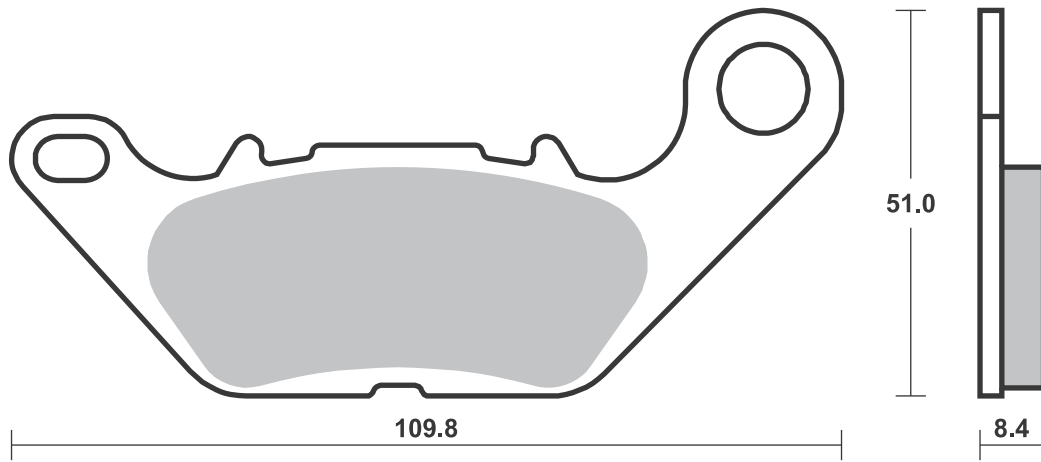





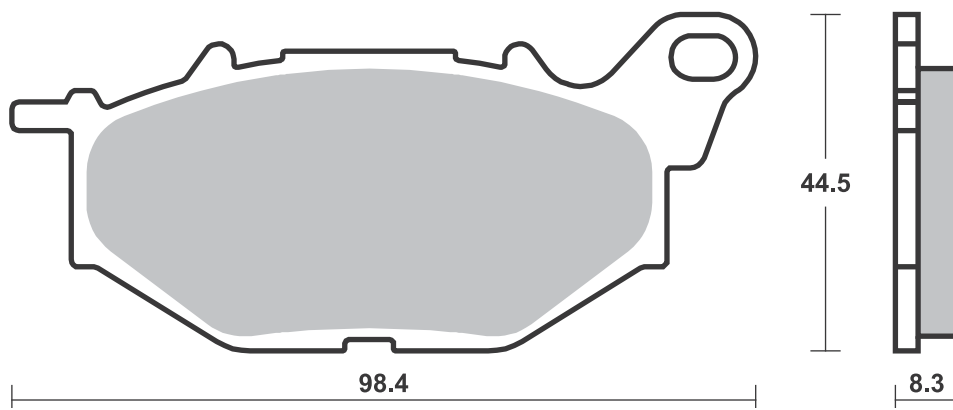
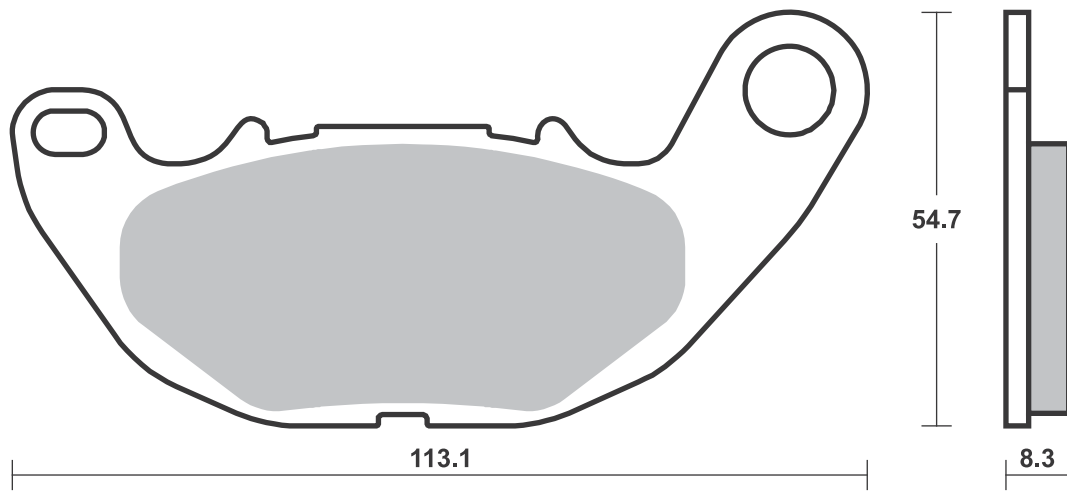



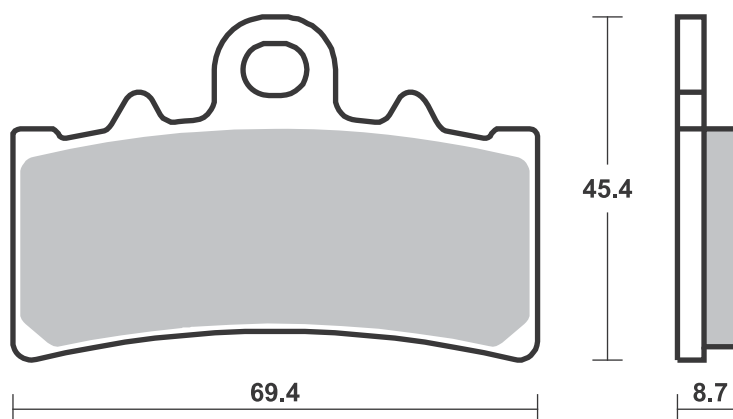
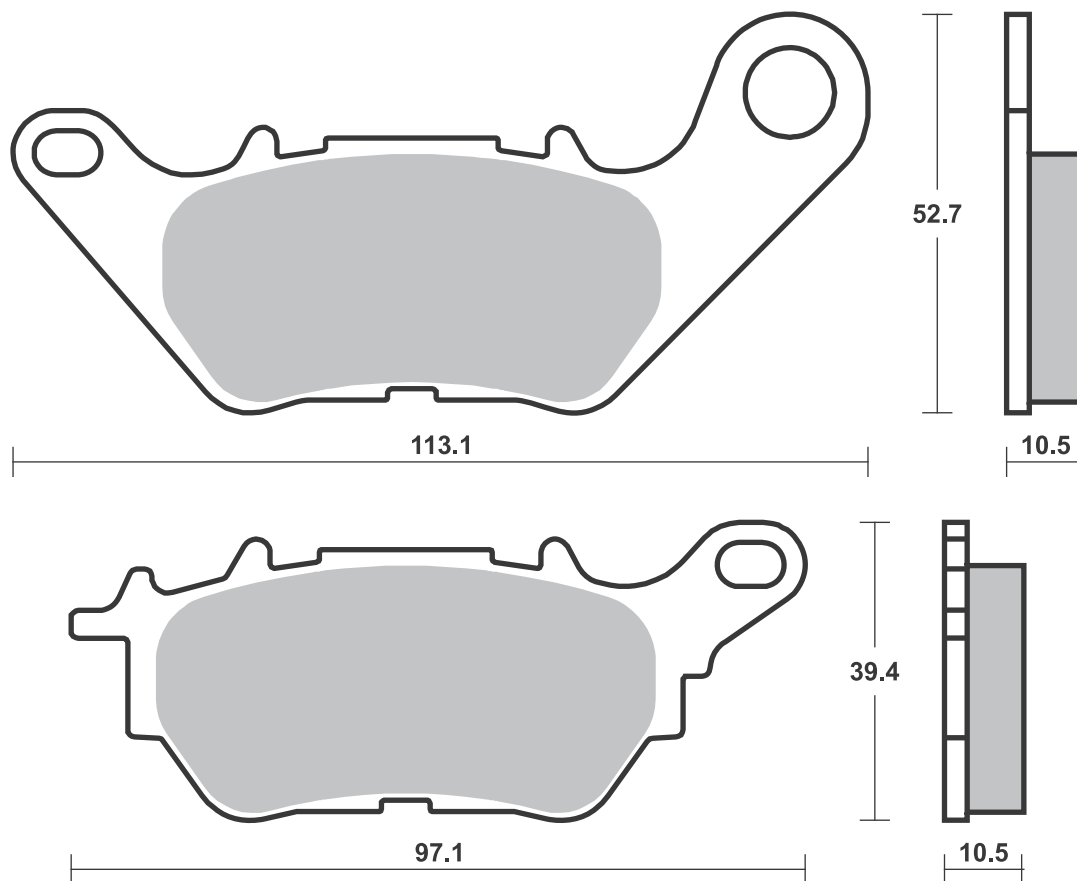





Available compounds **HF • DCC**

**SBS 501**

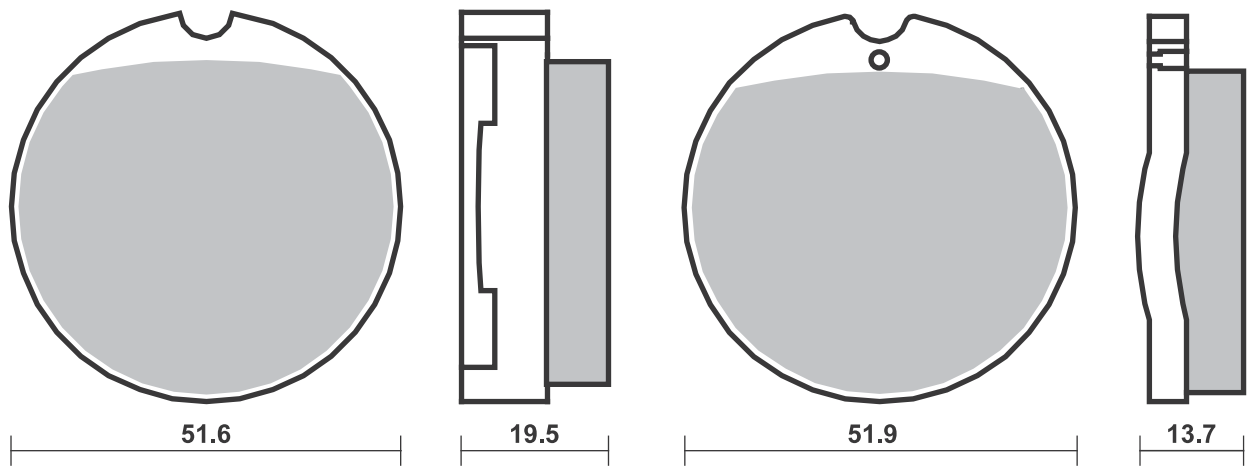

Available compounds **HF**

**SBS 502**

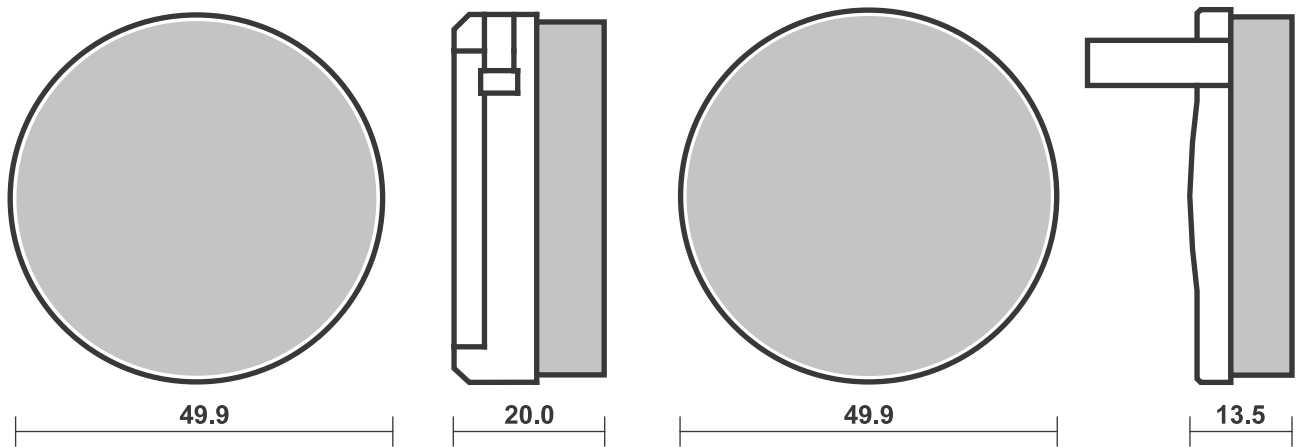

Available compounds **HF**

**SBS 503**

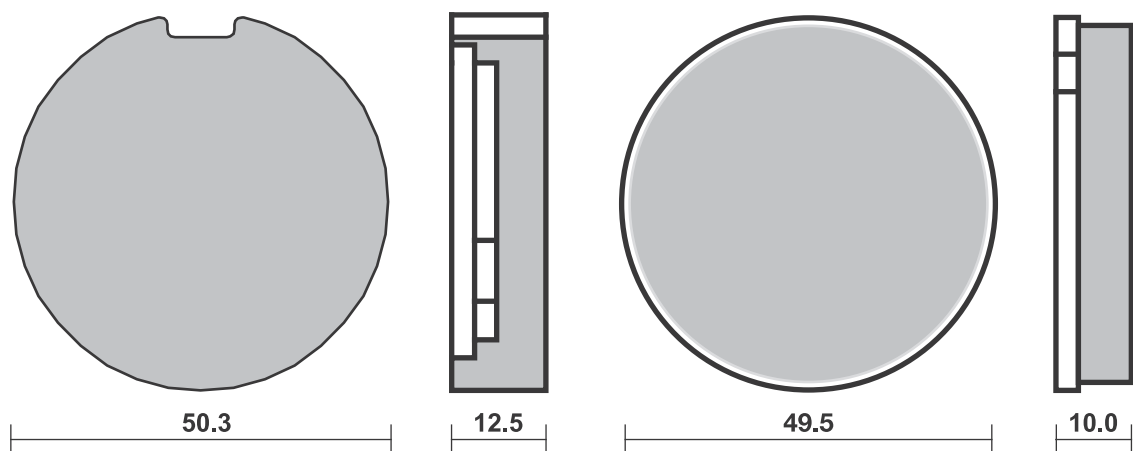

Brake Pad 1:1 Drawings,  
Compounds, Fitments

**SBS 504** Recommended compound



**ISR CALIPERS**

2 Piston (22-023/026)

**YAMAHA**

RD	250	73-77	HF	
TZ	250	82-85	HF	
RD	350	73-79	HF	
XS	360 B	76	HF	
RD	400	77	HF	HF
TX	500 A, B	74-77	HF	
XS	500	75-77	HF	
TX	650	72-73	HF	
XS	650	75-77	HF	
TX	750	73-74	HF	
TX	750 A	73-76	HF	

**SBS 505** Recommended compound



**NORTON**

MK2	850 Commando	73-75	HF	
MK3	850 Commando	75-77	HF	HF

**SBS 506** Recommended compound



**BENELLI**

	750 Sei	75-78	HF	
	900 Sei	84	HF	HF

**BERINGER**

2 Piston Classic Billet Caliper

**BIMOTA**

	all models	82-88	HF	HF
SB3	1000 D	83	HF	HF

**BMW**

R65	650 GS	87-92	HF	
R65	650 GS	91-92	HS	
R65	650 LS	82-85	HF	
R65/1	650	86		HF
K75	750	90		LS



**BMW**

K75	750 C	85-88	HF	
K75	750 RT	91-96		LS
K75	750 S, C	85-95	HF	HF
R80	800	77-85	HF	
R80	800 G/S P.-D.	86	HF	
R80	800 GS	81-87	HF	
R80	800 GS	91-92	HS	
R80	800 R	91-95		LS
R80	800 RT	83	HF	
R80/7	800	79-81		HF
K1	1000	89		LS
K100	1000 LT	87	HF	HF
K100	1000 LT	92-94		LS
K100	1000 LT ABS	89		LS
K100	1000 RS	90-92		LS
K100	1000 RS ABS	88-89		LS
K100	1000 RS, RT	83-89	HF	HF



**BMW**

R100	1000	81-84	HF	HF
R100	1000 CS,RS, RT	81-84	HF	HF
R100	1000 R	91-95		LS
R100	1000 RS	76-80		HF
R100	1000 RS	93-95		LS
R100	1000 S	78-80		HF
R100	1000 T	79-84		HF
K1100	1100 LT/SE	92-00		LS
K1100	1100 RS	93-96		LS
R1100	1100 RS	93-01		LS
K	1200 GT (K41)			
	With Integral ABS	02-05		LS
K	1200 RS	97-05		LS

**BREMBO RACING CALIPERS**

108N, P2 38

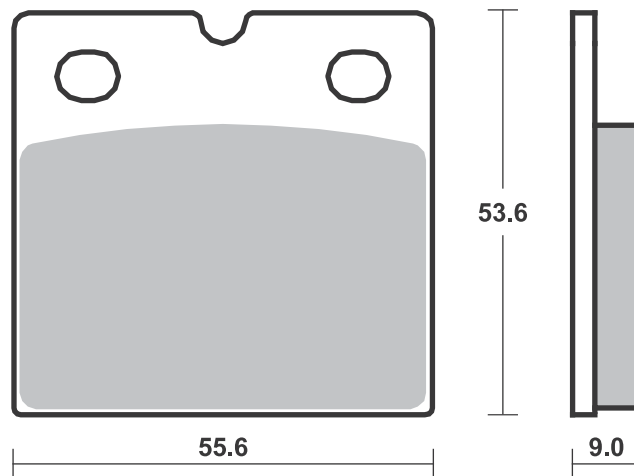
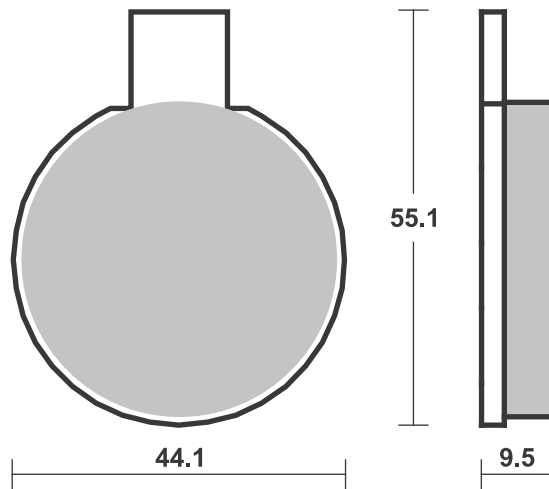
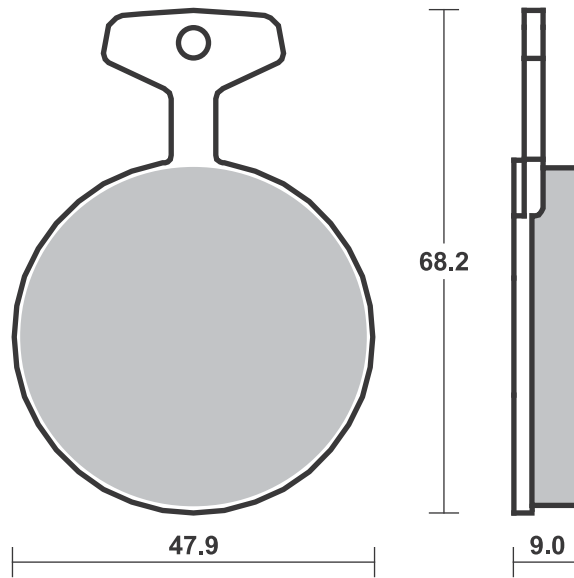

**SBS 506** Recommended compound

<b>BREMBO RACING CALIPERS</b>			
F08			
<b>DUCATI</b>			
250 Desmo	70-77	HF	
350 Desmo	70-77	HF	
350 F3	86-89	HF	HF
500 Sport	77-82	HF	HF
600 Pantah TL, SL	78-89	HF	HF
600 SL, TL Pantah	76-89	HF	
650 Pantah	84-89	HF	HF
750 F1	86-98	HF	HF
750 GT	74-76	HF	
750 Paso	87	HF	
750 Sport	90	HS	LS
750 SS	74-76	HF	HF
750 SS	91-98	HF	HF
851 Strada	91-92	HF	
860 GT	75-77	HF	
860 GT	85	HF	HF
888 Roche			
Replica	91		HF
900 GTS	77-79	HF	
900 Mike			
Hailwood			
Replica	85-86	HF	HF
900 S2 Desmo	85	HF	HF
900 Sport	77-78	HF	HF
900 SS	78-89	HF	HF
906 900 Paso	89	HF	
1000 /6 Mike			
Hailwood			
Replica	85	HF	HF
1000 Mille Replica	84-85	HF	HF
1000 S2 Desmo	85	HF	HF

<b>INDIAN</b>			
1700 Chief			
Blackhawk	11-13		H.L.S
1700 Chief Bomber	10-13		H.L.S
1700 Chief Classic	10-13		H.L.S
1700 Chief Dark			
Horse	10-13		H.L.S



<b>INDIAN</b>			
1700 Chief Deluxe	09-13		H.L.S
1700 Chief			
Roadmaster	09-13		H.L.S
1700 Chief			
Standard	09-13		H.L.S
1700 Chief Vintage	09-13		H.L.S
<b>JAWA</b>			
CZ 125 2T	95-00	HF	
CZ 125 MX	95-00	HF	
CZ 180	92	HF	
300 Trail	93	HF	
<b>LAVERDA</b>			
SFC 600	86-89	HF	HF
650 V-Six	93	HS	LS
1000 Jota	76-79	HF	HF
3C 1000 3CE, 3CL	74-75	HF	HF
RGS 1000	83	HF	HF
RGS 1000 Jota	86	HF	HF
SFC 1000	85-86	HF	HF
TGA 1000 Executive	84	HF	HF
1200 Mirage	78-80	HF	HF

<b>MOTO-GUZZI</b>			
NTX 350	90		HF
V35 350 C	82-86	HF	
V35 350 Florida	85-86	HF	
V35 350 GT	90	HF	
V35 350 III	87	HF	HF
V35 350 TT	86	HF	HF
NTX 650	90-02		HF
V65 650 Florida	86-94	HF	HF
V65 650 GT	90-94	HF	
NTX 750	90-93		LS
S3 750 Left	75-76	HF	
S3 750 Right	75-76	HF	
SP 750	91-92	HS	LS
V75 750	86-88	HF	HF
V75 750 Duna	86-90	HF	HF
V75 750 TT			
Paris-Dakar	86	HF	HF



<b>MOTO-GUZZI</b>			
850 Le Mans	76-79	HF	HF
T 850	74-76	HF	
T3 850	75-80	HF	HF
T4 850	75-82	HF	HF
T5 850	75-88	HF	HF
T5 850 N.T.	86-88	HF	HF
1000 California II	85-88	HF	HF
1000 California III C	91-95	HS	LS
1000 California III,			
Fuel Injection	89	HF	HF
1000 Daytona	91-02		HF
1000 Le Mans IV	85-89	HF	HF
1000 Le Mans, V	90-98	HS	LS
GT 1000 V	91	HS	LS
S 1000	90	HS	LS
SP 1000 III	91-94	HS	LS
SP 1000 Le Mans			
Left/Rear	79-83	HF	
SP 1000 Le Mans Right	79-83	HF	
V 1000 Strada	93-94	HF	
1100 California	96-99	HS	LS

<b>NORTON</b>			
600 Commander	90	HF	HF
600 Interpol	83-88	HF	HF
600 Wankel			
Classic	88-89	HF	HF
F-1 600	90		HF

<b>TRIUMPH</b>			
750 Bonneville			
U.K.	87	HF	HF

**SBS 507** Recommended compound

<b>YAMAHA</b>			
XS 250 C	77-78	HF	HF
XS 250 D, E	79-80	HF	
XS 360 C, D	77	HF	HF
RD 400	79	HF	
XS 400	77	HF	HF
SR 500	78-84	HF	
XS 500	77-81	HF	HF
XJ 650	80-82	HF	
XS 650	75-85	HF	HF
XS 650	77-79	HF	
XS 650	80-82		HF
XS 650 SE	80-82	HF	HF
XS 650 SJ, SK	82	HF	
XS 650 SK, Heritage	83	HF	HF
XJ 750 E	81-83	HF	
XS 750	77-80	HF	HF
XS 750 H, J, K	81-82		HF



<b>YAMAHA</b>			
XS 750 SE Left/Rear	79-80		HF
XS 850	80-81	HF	HF
XS 850 Left/Rear	81		HF
XV 920	81-82	HF	
XS 1100 E,F,G,H	78-81	HF	HF
XS 1100 SF, SG, SH,			
LG Left/Rear	79-81		HF

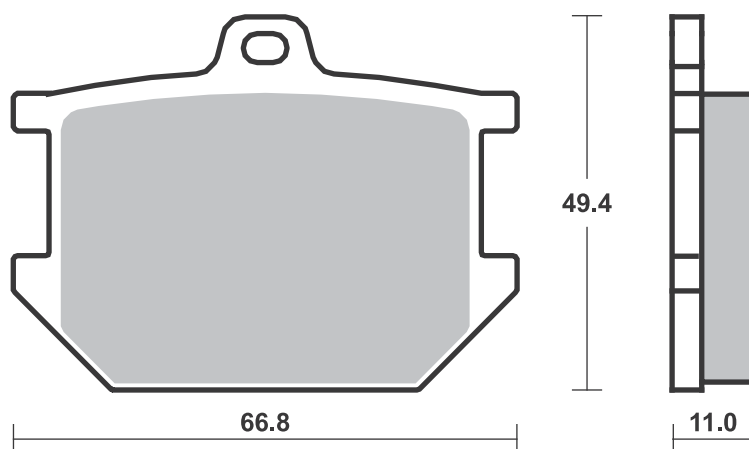
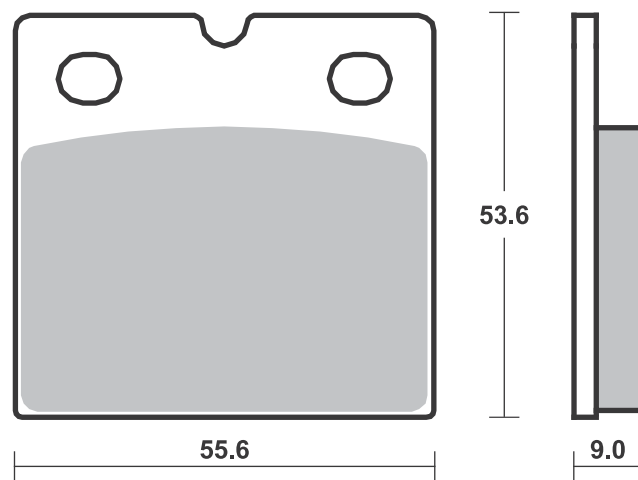





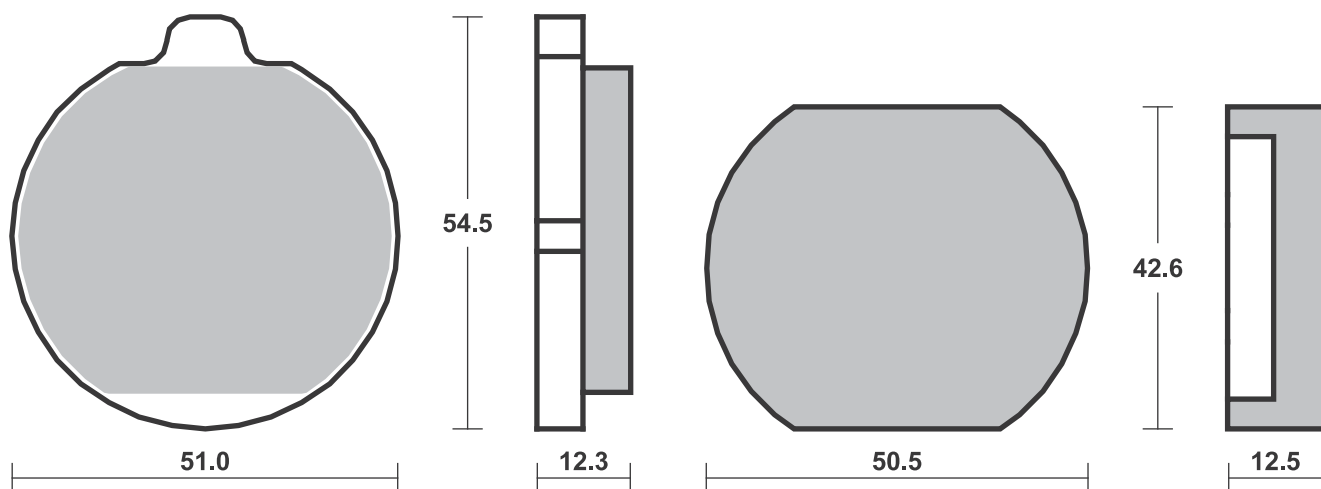
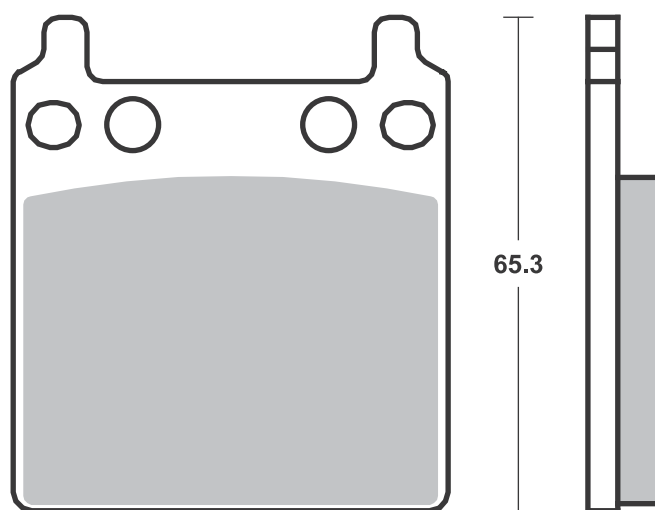
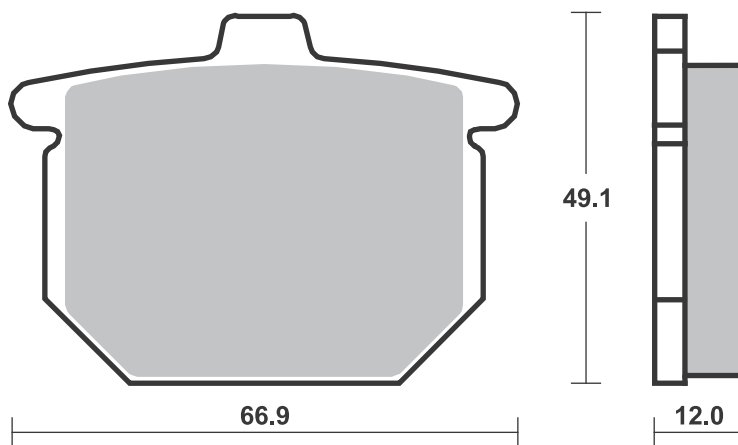



Available compounds **HF**

**SBS 511**

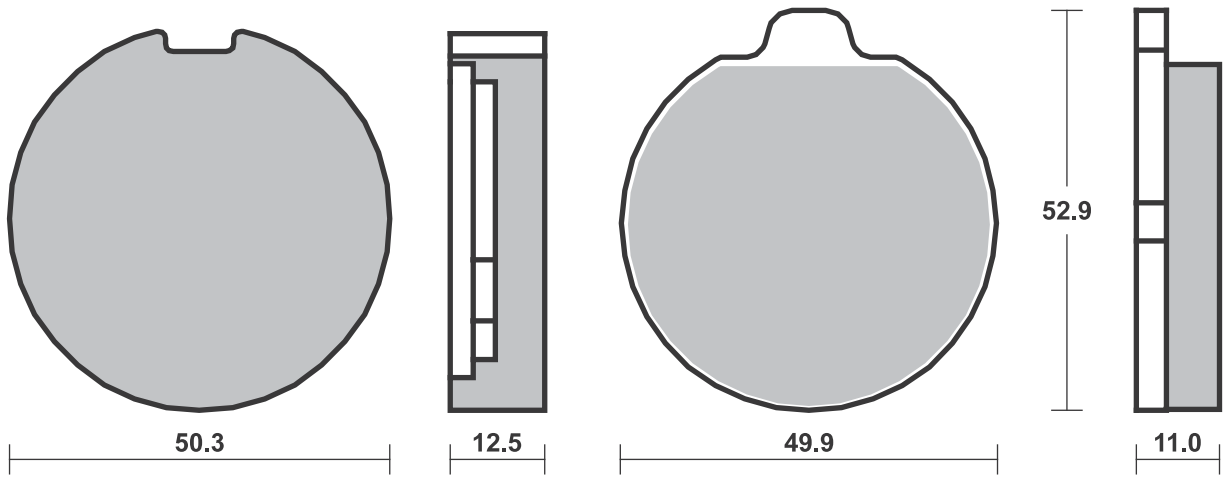

Available compounds **HF • H.HF • H.CT**

**SBS 512**

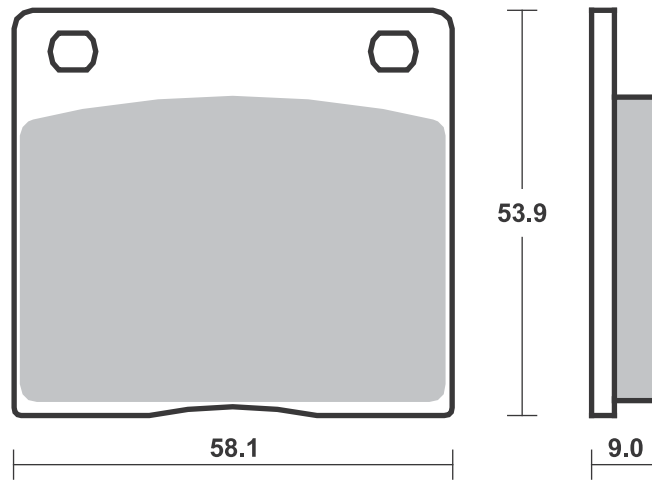

Available compounds **H.HF • H.CT**

**SBS 513**

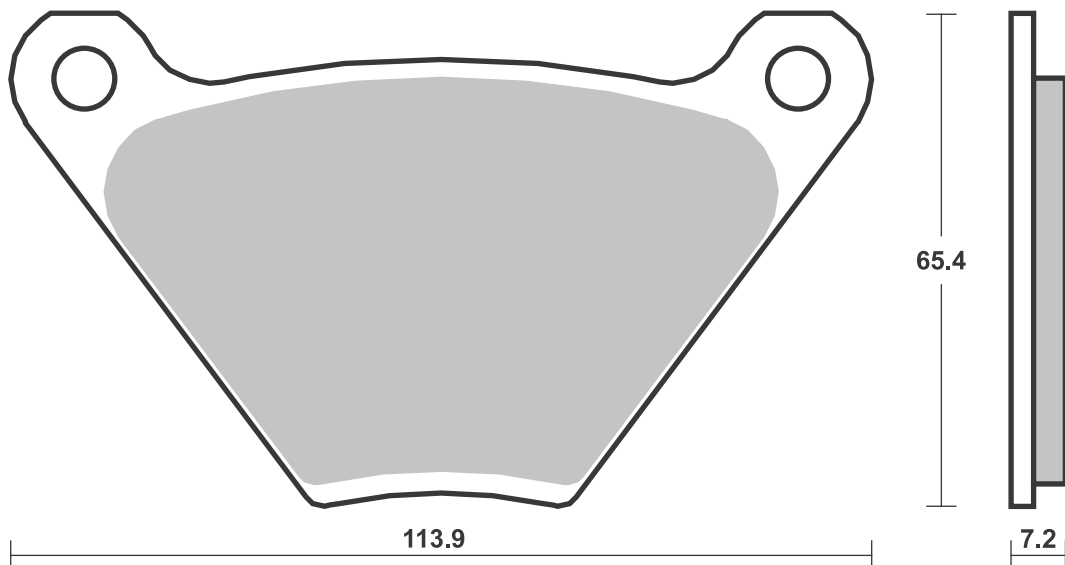



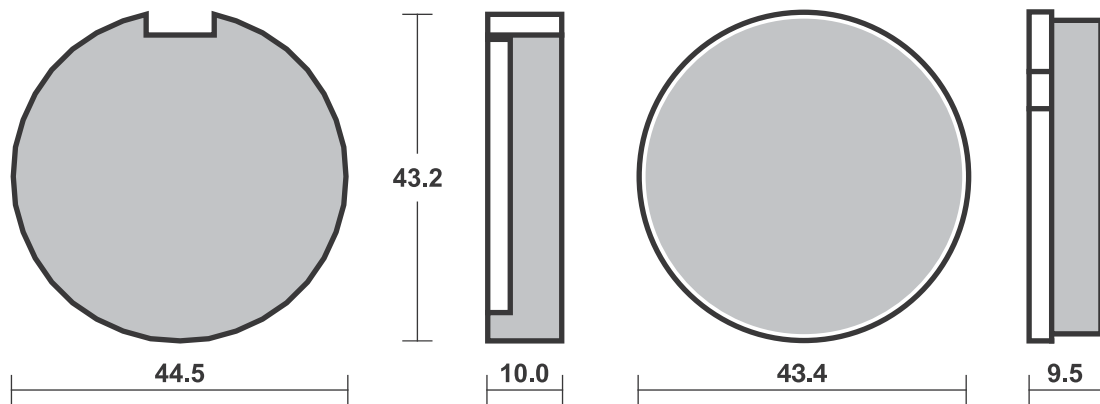
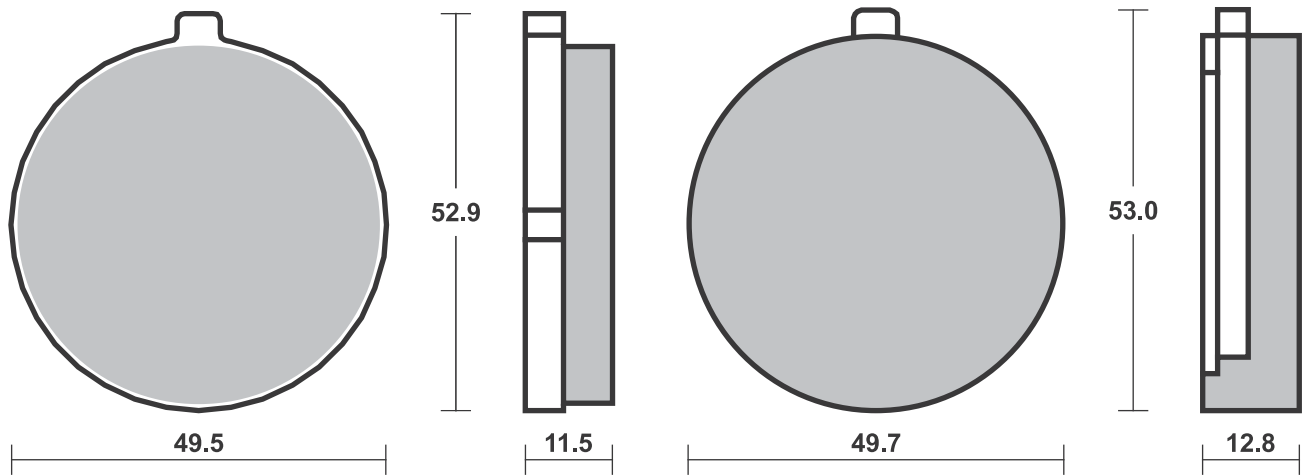
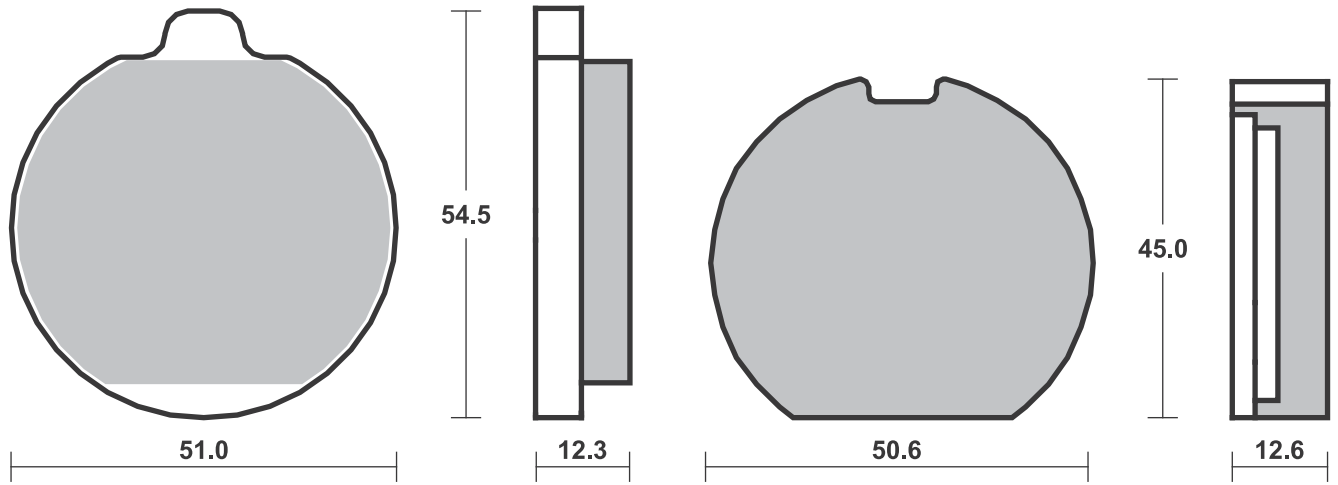

**SBS 517** Recommended compound

<b>HONDA</b>				
MT	125 R	78	<b>HF</b>	
CX	500	78-80	<b>HF</b>	
CB	750 F	77-80	<b>HF</b>	<b>HF</b>
CB	750 SS	77-79		<b>HF</b>
CB	900 F	78-80	<b>HF</b>	<b>HF</b>
CBX	1000	78-80	<b>HF</b>	<b>HF</b>
GL	1000 Gold Wing	81	<b>HF</b>	<b>HF</b>
GL	1000 Gr. Tour.			
	Gold Wing	81-82	<b>HF</b>	<b>HF</b>
GL	1000 K3 Gold Wing	78-79	<b>HF</b>	
GL	1100 A Gold Wing	79-83	<b>HF</b>	<b>HF</b>

**SBS 519** Recommended compound

<b>APRILIA</b>				
RS	250	97-02		<b>HF</b>
RS	250 Pista	04		<b>HF</b>
<b>ARMSTRONG</b>				
MX	500	86	<b>SI</b>	
MX	600	86	<b>SI</b>	
<b>ATK</b>				
ATK	250 CC,MX	91-92		<b>SI</b>
ATK	350 ES CC,MX,			
	STD	91-92		<b>SI</b>
ATK	350 GS	93	<b>SI</b>	<b>SI</b>
ATK	406 CC,MX	91-92		<b>SI</b>
ATK	560	84-88	<b>SI</b>	
ATK	604 ES CC,MX,			
	STD	91-92		<b>SI</b>
ATK	640	93	<b>SI</b>	<b>SI</b>
<b>BENELLI</b>				
	654 Sport	83	<b>HF</b>	<b>HF</b>
	900 Tornado 3	00-06		<b>LS</b>
TnT	1100	04		<b>LS</b>
<b>BETA</b>				
ALP	240	96		<b>RSI</b>
ALP	260	96		<b>RSI</b>
	500 GS, RV	84	<b>HF</b>	
<b>BIMOTA</b>				
YB7	400	89		<b>HF</b>
	500 Vdue	97-00		<b>HF</b>
	600 Bellaria	91		<b>HF</b>
YB9	600 SRI	97		<b>HF</b>
BB1	650 Supermono	97-00		<b>HF</b>
SB7	750	96-88		<b>HF</b>
YB4	750	89		<b>HF</b>
1D	851 Tesi	91		<b>HF</b>
1D	900 Tesi	93		<b>HF</b>
DB2	900	92-00		<b>HF</b>
DB3	900 Mantra	97-00		<b>HF</b>
DB4	900	99-00		<b>LS</b>
1D	906 Tesi	91		<b>HF</b>

<b>BIMOTA</b>				
	1000 Furano	92-93		<b>HF</b>
2D	1000 Tesi	04-06		<b>LS</b>
SB8	1000 R	98-00		<b>LS</b>
SB8K	1000	06		<b>LS</b>
SB8K	1000 Santamonica	07-09		<b>LS</b>
YB11	1000	97-00		<b>HF</b>
YB6	1000	89		<b>HF</b>
YB8	1000	90		<b>HF</b>
	1002 Dieci	91		<b>HF</b>
DB7	1099	09		<b>LS</b>
SB6	1100	97-00		<b>HF</b>
<b>BREMBO RACING CALIPERS</b>				
	Goldline 20.5161.42/51,			
	road			
<b>CAGIVA</b>				
	125 Aletta Oro	86-89	<b>HF</b>	<b>HF</b>
	125 Blues	87-85		<b>HF</b>
	125 Cruiser	88-89		<b>HF</b>
	125 Enduro	86	<b>HF</b>	
	125 Raptor	03-10		<b>HF</b>
	125 Tamanaco	89		<b>HF</b>
WMX	125 GP-Replica	86-89	<b>SI</b>	
WRX	125	85	<b>HF</b>	
	200 Elefant	86	<b>HF</b>	
MXR	250	82	<b>HF</b>	
WMX	250 GP	82	<b>SI</b>	
	350 Alazzurra	85-87	<b>HF</b>	<b>HF</b>
	350 Elefant	86-89		<b>HF</b>
T4	350 R	87-99	<b>HF</b>	
	500 Mito	07		<b>LS</b>
T4	500 E	87-90	<b>HF</b>	
WMX	500	85-86	<b>SI</b>	
WMX	500 Cross	87	<b>SI</b>	<b>SI</b>
SP	525 Mito	08-10		<b>LS</b>
	650 Alazzurra	84	<b>HF</b>	<b>HF</b>
	650 Elefant	86-87		<b>HF</b>
<b>CAN-AM</b>				
	200 ASE	86	<b>SI</b>	
	250 ASE	86	<b>SI</b>	

<b>CAN-AM</b>				
	250 MX LC	86	<b>SI</b>	
	350 ASE	86	<b>SI</b>	
	406 ASE	87	<b>SI</b>	
	500 ASE	86	<b>SI</b>	
	500 MX	86	<b>SI</b>	
	560 Sonic	86-14	<b>SI</b>	
<b>DERBI</b>				
	125 Mulhacen	07		<b>HF</b>
	125 Terra	07		<b>HF</b>
	250 RC	85	<b>HF</b>	
<b>DUCATI</b>				
	350	75-78	<b>HF</b>	
	350 F3	86-90	<b>HF</b>	<b>HF</b>
	350 GTV	77	<b>HF</b>	<b>HF</b>
	350 Indiana	86-91		<b>HF</b>
	350 Paso	86	<b>HF</b>	<b>HF</b>
	350 Sport	77-80	<b>HF</b>	<b>HF</b>
	400 Monster			
	(Japan)	01-06		<b>LS</b>
	400 SS, Junior	92-97		<b>HF</b>
	400 SS, Nuda	92-96		<b>HF</b>
	500 GTV	77-82	<b>HF</b>	<b>HF</b>
	500 Pantah	85-89	<b>HF</b>	<b>HF</b>
	500 Sport Desmo	77-82	<b>HF</b>	
	500 Twin GTL	75-80	<b>HF</b>	
	502 Single	93		<b>HF</b>
	502 Supermono	93		<b>HF</b>
	600 Monster	00-01		<b>LS</b>
	600 SL, TL Pantah	76-89		<b>HF</b>
	600 SS			
	Supersport	95-00		<b>HF</b>
M	600 Monster	94-99		<b>HF</b>
	620 Monster			
	Dark i.e.	02-06		<b>LS</b>
	620 Monster i.e.,			
	s.i.e.	02-06		<b>LS</b>
	650 Indiana	86-89		<b>HF</b>
	695 Monster	07-12		<b>LS</b>
	748 , S	99-02		<b>LS</b>
	748 Biposto	95-98		<b>HF</b>



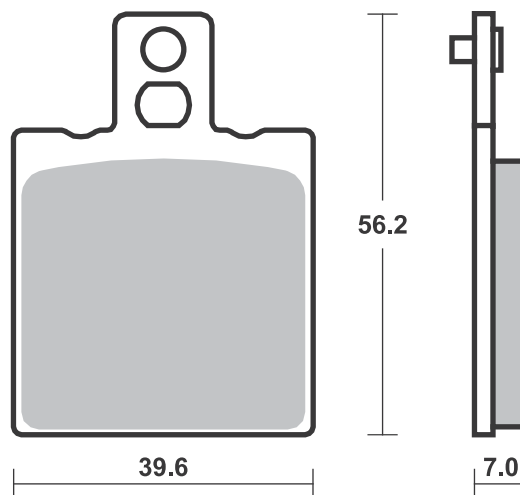
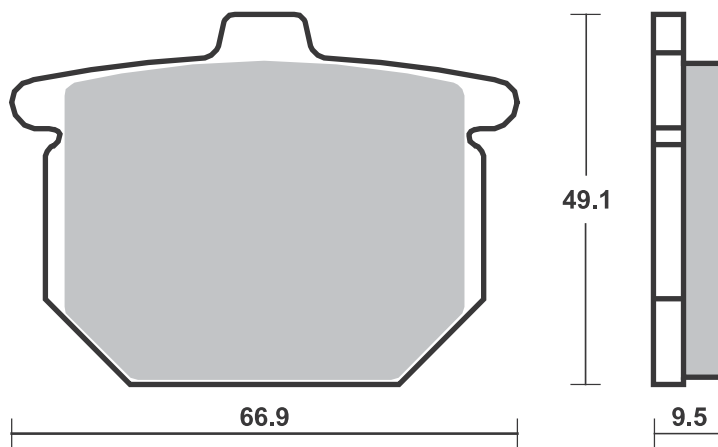



DUCATI		
748 R	00-02	LS
748 SP	95-97	HF
748 SPS	98-99	LS
750 Indiana	85-86	HF
750 Monster	96-99	HF
750 Monster	00-01	LS
750 Monster i.e.	02	LS
750 Paso	86	HF HF
750 Paso	87	HF
750 Paso	88	HF
750 SS		
Supersport	95-99	HF
750 SS, Carenara	92-98	HF
750 SS, Nuda	92	HF
750 Super Sport	92-94	HF
800 Monster		
Dark i.e., s i.e.	03-07	LS
800 Monster i.e., s i.e.	03-07	LS
800 Monster S2R	05-07	LS
800 Monster S2R		
ABS	05-07	LS
851 Strada	89	HF
851 Superbike	90	HF
888 SP V	93	HF
888 SP4	92-95	HF
888 SPO	93	HF
888 SPS	92-95	HF
888 Strada	93	HF
888 Superbike	93	HF
900 FE	97-98	HF
900 M, IL Monster	93-99	HF
900 Monster	00-01	LS
900 Monster i.e.	02	LS
900 SL	92-97	HF
900 SS	90-94	HF
900 SS		
Supersport	95-97	HF
900 SSR	92	HF
906 900 Paso	89	HF
907 900 I. E.	90-93	HF
M 900 Street		
Monster	94-99	HF
MH 900	00-01	LS
916 Biposto	94	HF
916 Monster S4	01-03	LS
916 SPS	97-98	LS
996 , SPS	99-01	LS
996 Monster S4R	04-06	LS
996 R	01	LS
998 , S	02	LS
998 R	02	LS
1000 Monster		
Dark i.e., s i.e.	03-06	LS
1000 Monster i.e., s i.e.	03-06	LS

FANTIC		
250 Coach	91-98	HF

GILERA		
50 Sioux	92	HF HF
125 Arizona Hawk	86-89	HF
125 Crono	92-95	HF
125 Freestyle	92-95	HF
125 HX, HE	83	HF
125 KK, KR, KZ	86-91	HF



GILERA		
125 MX1, MRX,		
SP01	89-93	HF
125 R1, R1S	90-92	HF
125 SP02	90-94	HF
CX 125	91-95	HF
MXR 125	90	HF
200 RX	83	HF
250 Arizona Hawk	86-91	HF
250 Arizona Rally	86-91	HF
250 Arizona Rally	08	HF
NGR 250	85	HF
350 Saturno		
Bialbero	90	HF
XRT 350	90	HF
500 Saturno		
Bialbero	90	HF
500 Saturno		
Piuma	90-94	HF
600 Nordwest	91-94	HF
RC 600	88	HF
XRT 600	89	HF

HUSQVARNA		
CR 125	85-90	SI
CX 125	84-85	SI
200 Prof	86	SI SI
CR 240	84-85	SI
CR 250	85-87	SI
CX 250	84-85	SI
400 Enduro	85-88	SI
430 Enduro	85-88	SI
CR 500	86-87	SI
CX/CR 500	84-85	SI
TC 500	86	SI
504	83	SI
TE 510	86-87	SI

ISR CALIPERS		
2 Piston (22-027/028/029)		
4 Piston (22-025)		

ITALJET		
350	83	HF

KEEWAY		
125 Enduro	07-08	HF
125 X-Ray	07-08	HF

KTM		
LC 125	85	SI
LC 125	86	SI SI
MX 125	85	SI
MX 125	86	SI SI
XC 125	85	SI
XC 125	86-89	SI SI
250 Baja	86-89	SI
250 Country,Baja	85	SI
LC 250	85	SI
LC 250	86	SI SI
MC 250	83-84	SI SI
MX 250	83-84	SI SI
MX 250	85	SI
MX 250	86	SI SI
XC 250	85	SI
XC 250	86-89	SI SI
XC 300	85	SI
XC 300	86-90	SI SI



KTM		
350 Country		
Cross	85	SI
350 GS	83-85	SI
GS4 350 500 K4	82-83	SI
K4 350 500 K4	82-83	SI
XC 350 , MC	81-83	SI
390 GS	83	SI
XC 390 , MC	81-83	SI
XC 420 , MC	81-83	SI
MC 495 Leleu	82-83	SI
MX 495 Leleu	82-83	SI
GS 500 500 K4		
Enduro	83	SI
LC 500	85	SI
LC 500	86-89	SI SI
MX 500	85	SI
MX 500	86	SI SI
XC 500 , MC	81-83	SI
4T 600 Enduro	84-86	SI
GS 600	85	SI
XC 600 Cross	85	SI
XCE 600 Cross	85	SI
620 Duke	96-98	HF
640 Duke	99-02	HF

LAVERDA		
GS 350 Lesmo	86-89	HF HF
500 Alpino, S	77-83	HF HF
OR 600 Atlas	86-90	HF
650	92	HF
668 668	96-97	HF
668 Ghost,		
Diamante	97	HF
750 Cup	98-01	HF
750 Diamante	97-01	HF
750 Ghost Strike	97-01	HF
750 S Formula	97-01	HF
750 S, S Carenata	97-01	HF
750 Sport	99-01	HF
750 Strike/		
Black Strike	99-01	HF
750 T8	98-01	HF
JOTA 1000	95	HF

MAICO		
GM 250 LC	85	SI
MD 250	83-85	SI SI
GM 500 LC	85-86	SI

MALAGUTI		
50 Enduro	85-87	HF
MRX 50	89	HF
RST 50	90	HF HF

MOTO-GUZZI		
125 Custom	85	HF
125 Enduro TT	85	HF
BX 125	92	HF HF
240 /4	77	HF
250 TS	75-76	HF
350	77-81	HF HF
350 Falco	88	HF HF
350 Imola	78-84	HF HF
350 Nevada	92-97	HF
NTX 350	88	HF HF
NTX 350	90	HF
V35 350 C	82-86	HF

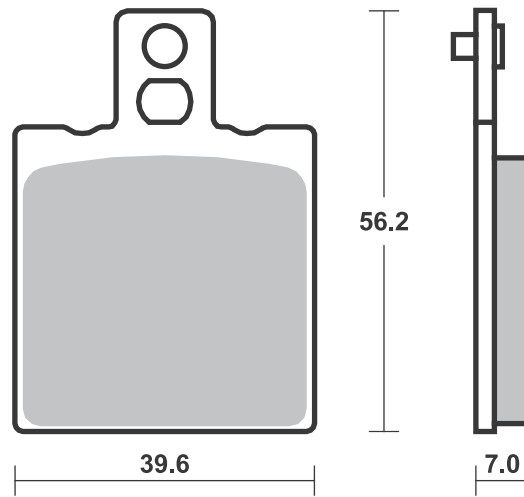



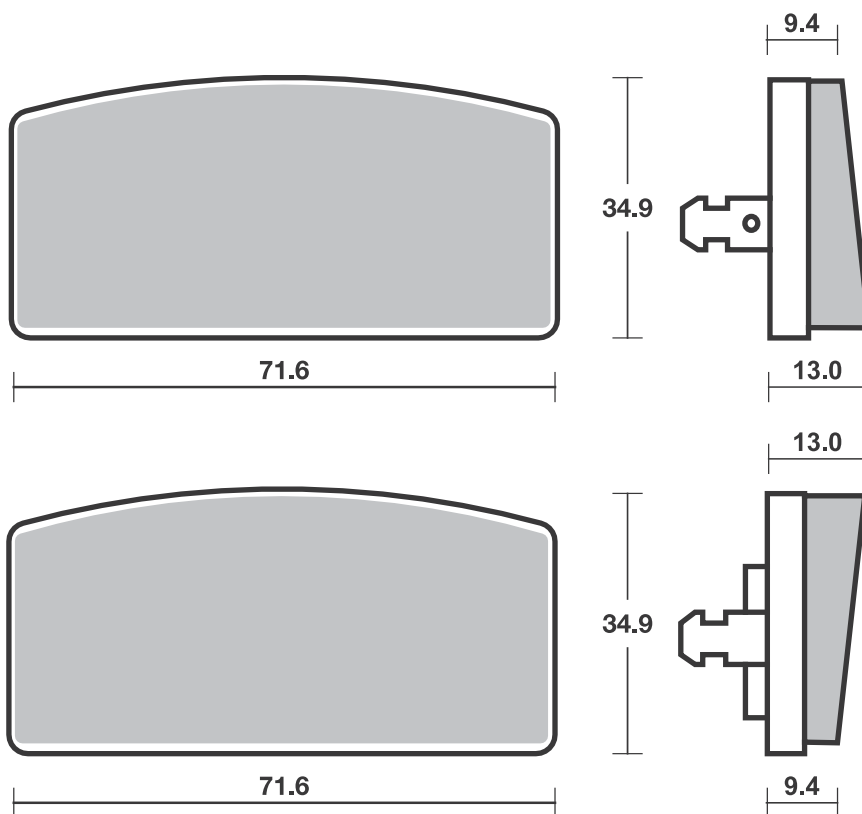
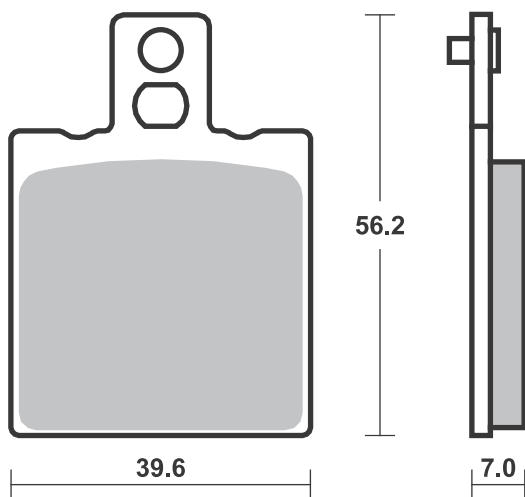





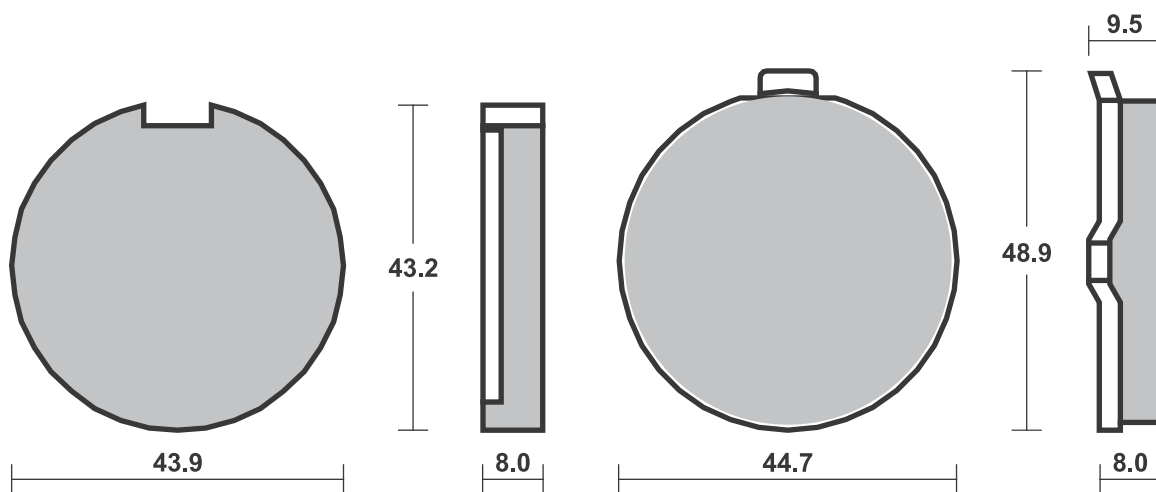
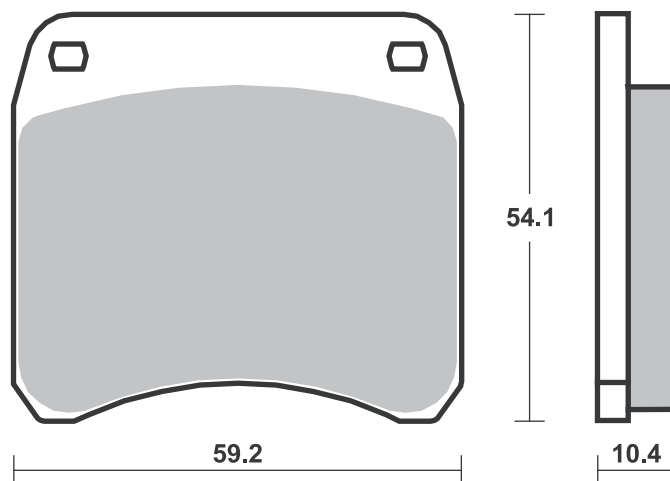
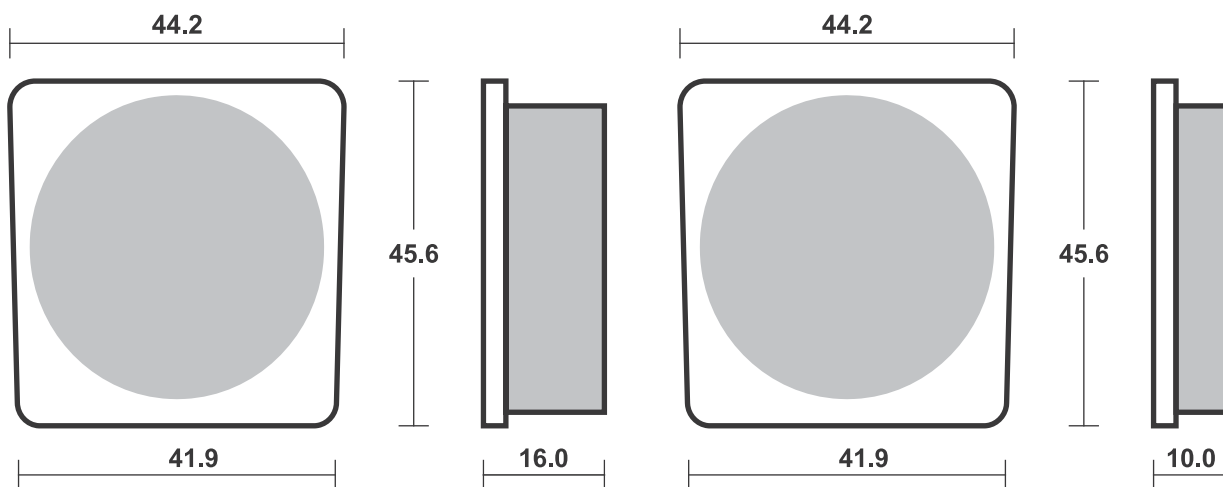



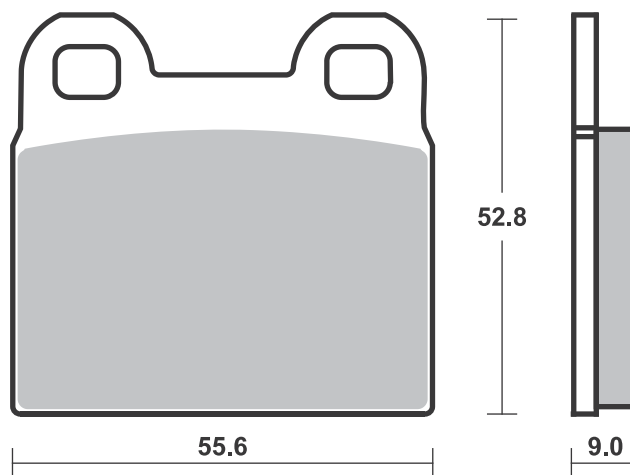
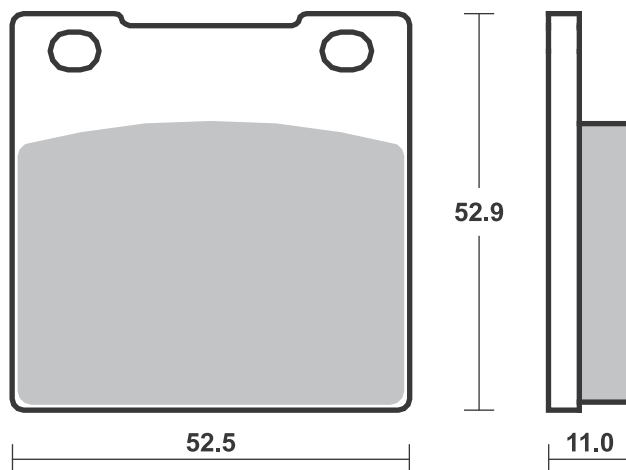
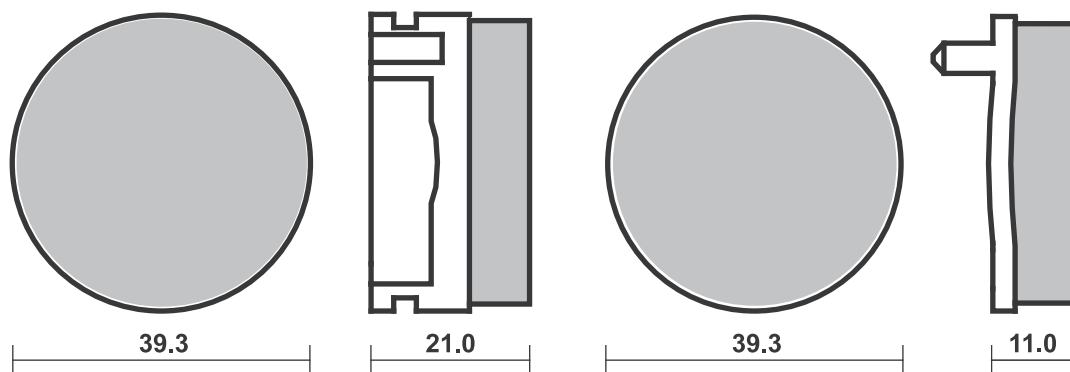



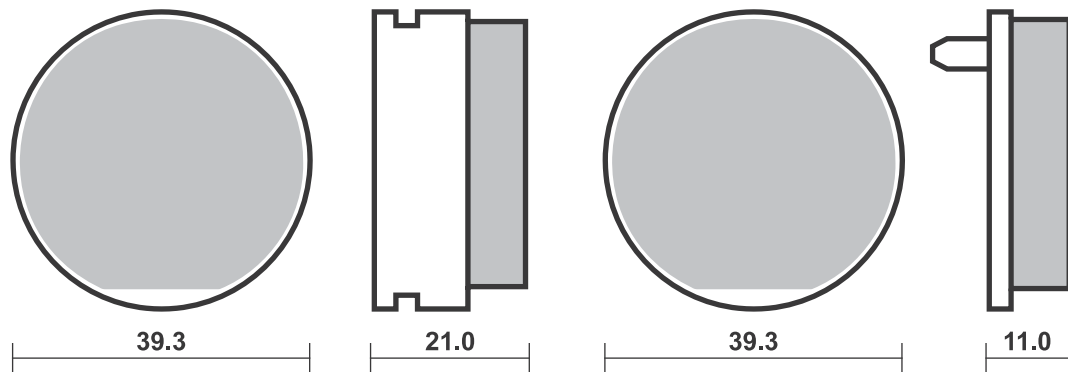
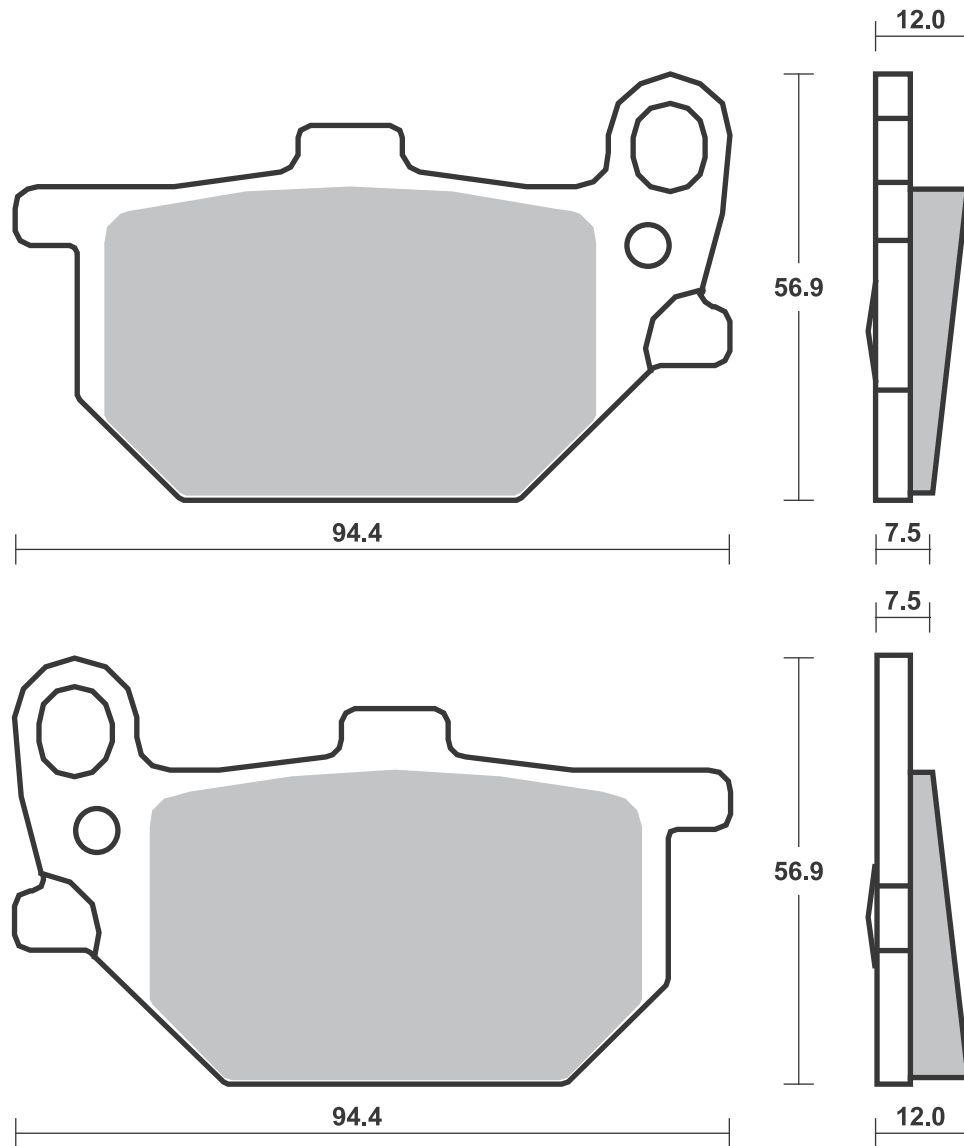

Brake Pad 1:1 Drawings,  
Compounds, Fitments





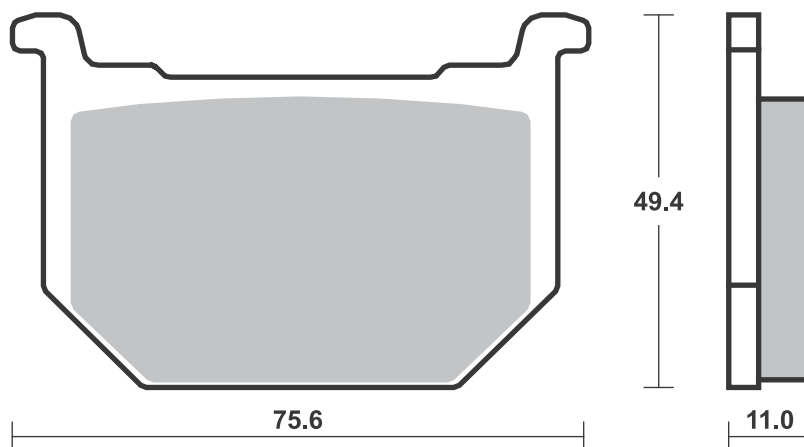
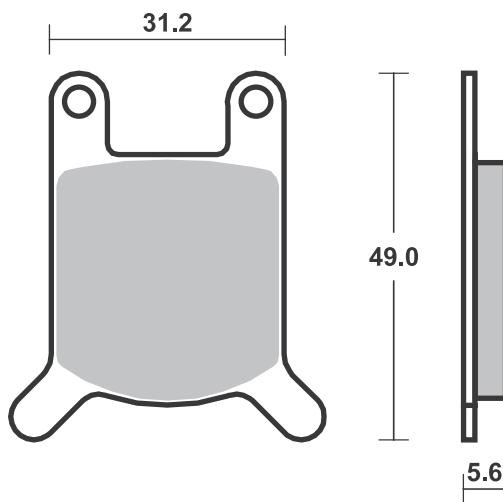
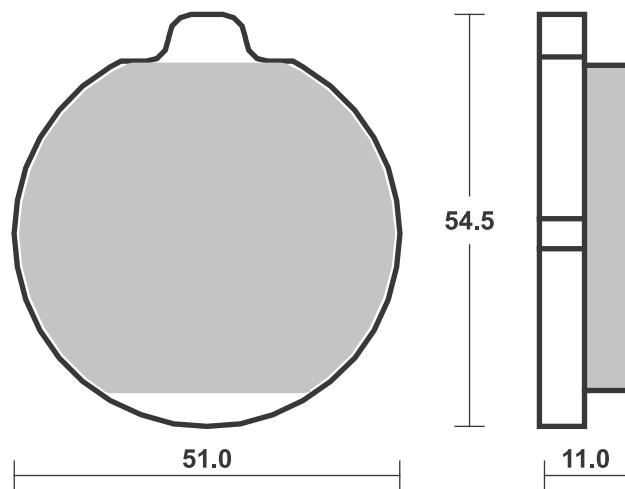



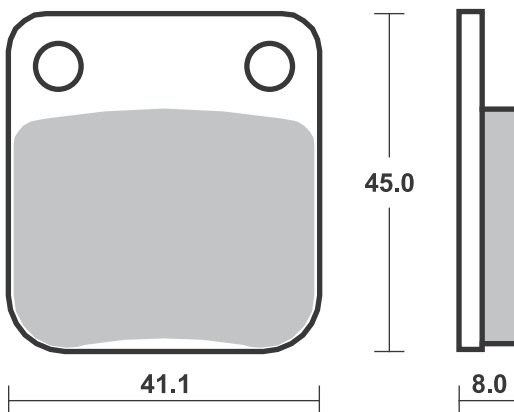
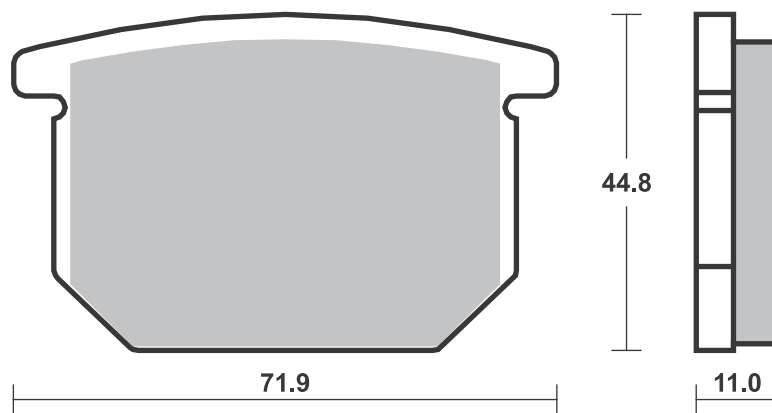

**SBS 537** Recommended compound



<b>HARLEY DAVIDSON</b>			
XLH	883	70-83	<b>H.HF</b>
XL	1000	78	<b>H.HF</b>
XLCH	1000	78-80	<b>H.HF</b>
XLH	1000 Sportster	79-85	<b>H.HF</b>
XLS	1000 Anniversary	82	<b>H.HF</b>
XLS	1000 Roadster	79-82	<b>H.HF</b>
XLS	1000 Sportster	83	<b>H.HF</b>
XLX	1000 61	83-84	<b>H.HF</b>
XR	1000	85	<b>H.HF</b>
FX	1200	74-80	<b>H.HF</b>
FXE	1200	74-80	<b>H.HF</b>
FXS	1200	78-79	<b>H.HF</b>
FLHT	1340 Tour Glide	84	<b>H.HF</b>
FXB	1340 80	80-81	<b>H.HF</b>
FXB	1340 Sturgis	82	<b>H.HF</b>
FXE	1340	82	<b>H.HF</b>
FXE	1340 80	78-81	<b>H.HF</b>



<b>HARLEY DAVIDSON</b>			
FXE	1340 Super Glide	83-84	<b>H.HF</b>
FXEF	1340 80 Fat Bob	79-81	<b>H.HF</b>
FXR	1340	78-81	<b>H.HF</b>
FXR	1340 Super Glide	82-83	<b>H.HF</b>
FXRS	1340 Low Glide	82-84	<b>H.HF</b>
FXRS	1340 Super Glide II	82-83	<b>H.HF</b>
FXRT	1340 Super Glide II	83	<b>H.HF</b>
FXS	1340 80	79-81	<b>H.HF</b>
FXS	1340 Low Rider	82	<b>H.HF</b>
FXSB	1340 Low Rider	83	<b>H.HF</b>
FXWG	1340 80	80-81	<b>H.HF</b>
FXWG	1340 Wide Glide	82-84	<b>H.HF</b>

**SBS 539** Recommended compound



<b>KAWASAKI</b>			
KZ	440 H	82-84	<b>HF</b>
KZ	650	81-84	<b>HF</b>
KZ	650 F	81-84	<b>HF</b>
KZ	700	83-88	<b>HF</b>
GPZ	750	82	<b>HF</b>
KZ	750 , LTD	80-81	<b>HF</b>
KZ	750	84-86	<b>HF</b>
KZ	750 E	80-81	<b>HF</b>
KZ	750 GT	82-85	<b>HF</b>
KZ	750 L	80-82	<b>HF</b>
KZ	750 LTD Belt Drive	83-85	<b>HF</b>
KZ	750 LTD Twin	82	<b>HF</b>
KZ	750 Sp.	83-84	<b>HF</b>
KZ	750 Y1, N, LTD	82-85	<b>HF</b>
KZ	1000	87-01	<b>HF</b>



<b>KAWASAKI</b>			
KZ	1000 F1	80-82	<b>HF</b>
KZ	1000 J	79-83	<b>HF</b>
KZ	1000 K, M, CSR	81-84	<b>HF</b>
KZ	1000 LTD	81-84	<b>HF</b>
KZ	1000 MKII	79-80	<b>HF</b>
KZ	1000 Police	82-01	<b>HF</b>
KZ	1000 ST	79-81	<b>HF</b>
GPZ	1100	81-82	<b>HF</b>
KZ	1100 , Spectre	82-83	<b>HF</b>
KZ	1100 GP	81	<b>HF</b>
KZ	1100 L1, LTD	83	<b>HF</b>

**SBS 540** Recommended compound



<b>KAWASAKI</b>			
KZ	305	81-82	<b>HF</b>
KZ	305	87-88	<b>HF</b>
KZ	440 , LTD	83-85	<b>HF</b>
KZ	440	83	<b>HF</b>
KZ	440 C, Twin	81-83	<b>HF</b>
KZ	440 H	82-84	<b>HF</b>
KZ	550	80-83	<b>HF</b>
KZ	550	81-83	<b>HF</b>
KZ	550	83-84	<b>HF</b>
KZ	650 , CSR	81-82	<b>HF</b>
KZ	700	83-88	<b>HF</b>
GPZ	750	82	<b>HF</b>
KZ	750 , LTD	80-81	<b>HF</b>
KZ	750	84-86	<b>HF</b>
KZ	750 E	80-81	<b>HF</b>
KZ	750 GT	82-85	<b>HF</b>
KZ	750 L	80-82	<b>HF</b>



<b>KAWASAKI</b>			
KZ	750 L	84-86	<b>HF</b>
KZ	750 L3	83	<b>HF</b>
KZ	750 LTD Belt Drive	83-85	<b>HF</b>
KZ	750 LTD Twin	82	<b>HF</b>
KZ	750 M1	82-85	<b>HF</b>
KZ	750 R1	82	<b>HF</b>
KZ	750 Sp.	83-84	<b>HF</b>
KZ	750 Y1, N, LTD	82-85	<b>HF</b>
KZ	1000	87-01	<b>HF</b>
KZ	1000 J	79-83	<b>HF</b>
KZ	1000 K, M, CSR	81-84	<b>HF</b>
KZ	1000 LTD	81-84	<b>HF</b>
KZ	1000 Police	82-01	<b>HF</b>
KZ	1000 RE1, R2	82-84	<b>HF</b>
GPZ	1100	81-82	<b>HF</b>
KZ	1100 , Spectre	82-83	<b>HF</b>
KZ	1100 GP	81	<b>HF</b>



<b>KAWASAKI</b>			
KZ	1100 L1, LTD	83	<b>HF</b>

Available compounds

**H.HF • H.CT**

**SBS 537**

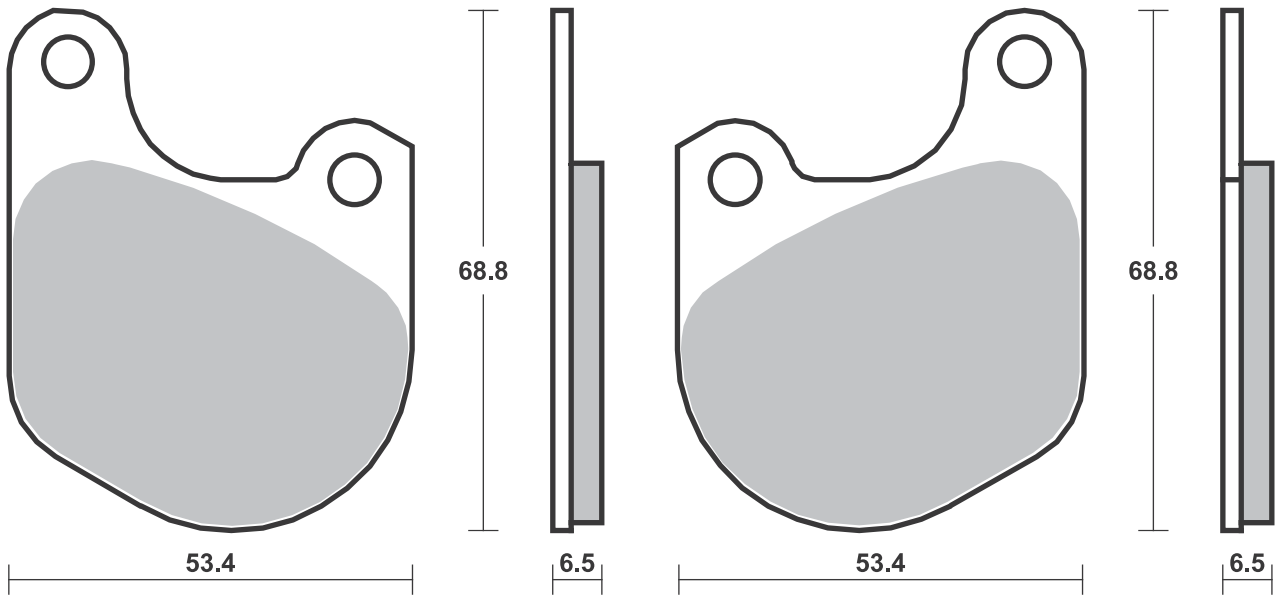

Available compounds

**HF • DCC**

**SBS 539**

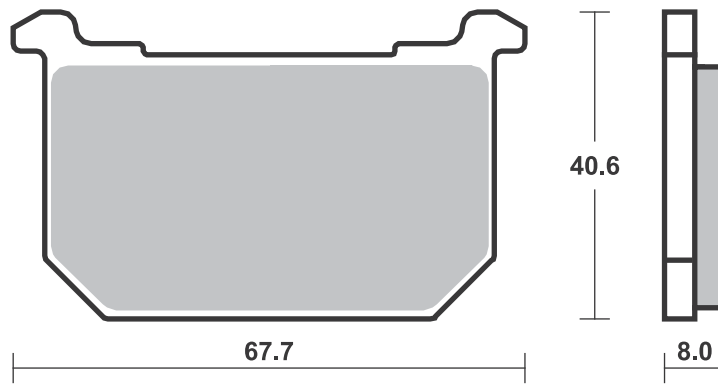

Available compounds

**HF**

**SBS 540**

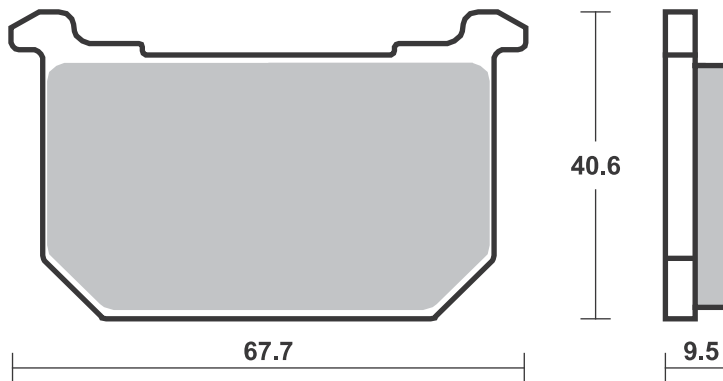





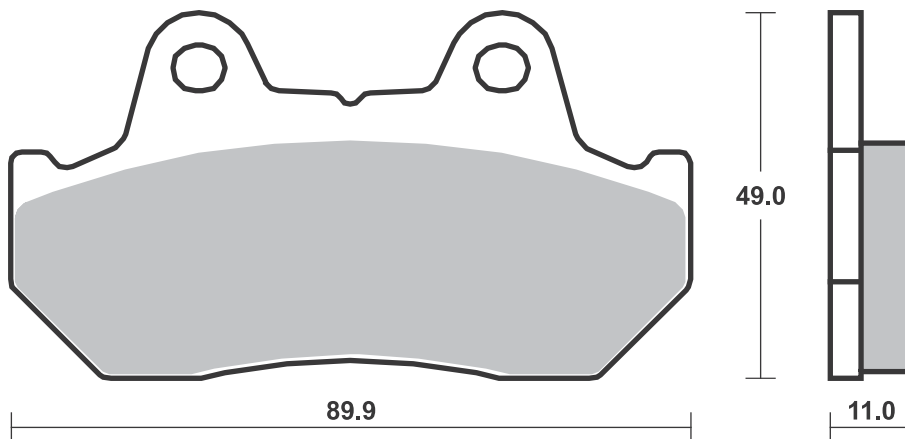
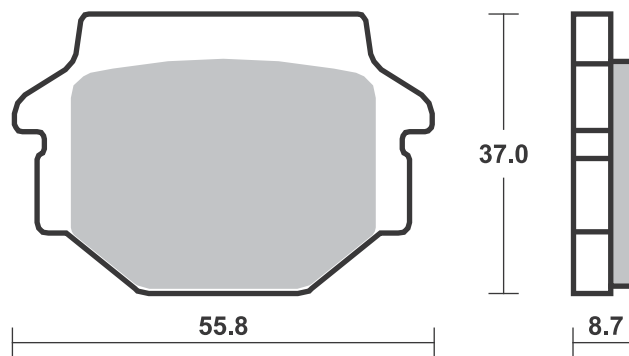
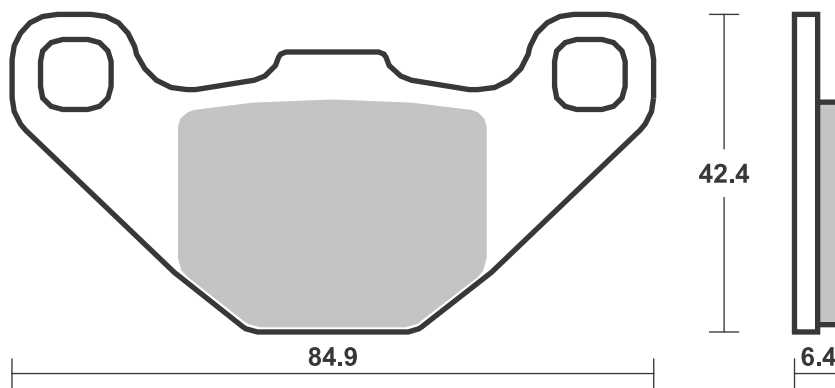



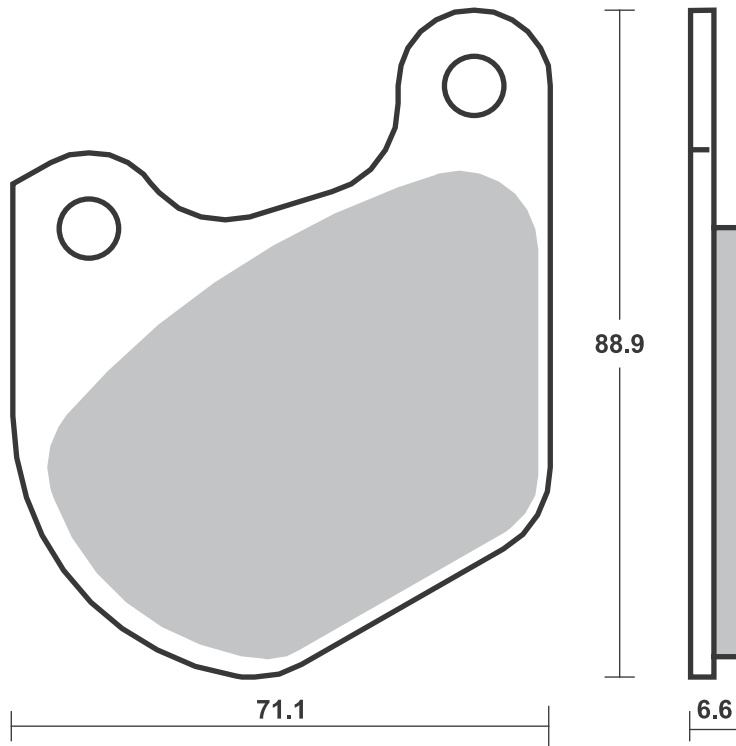
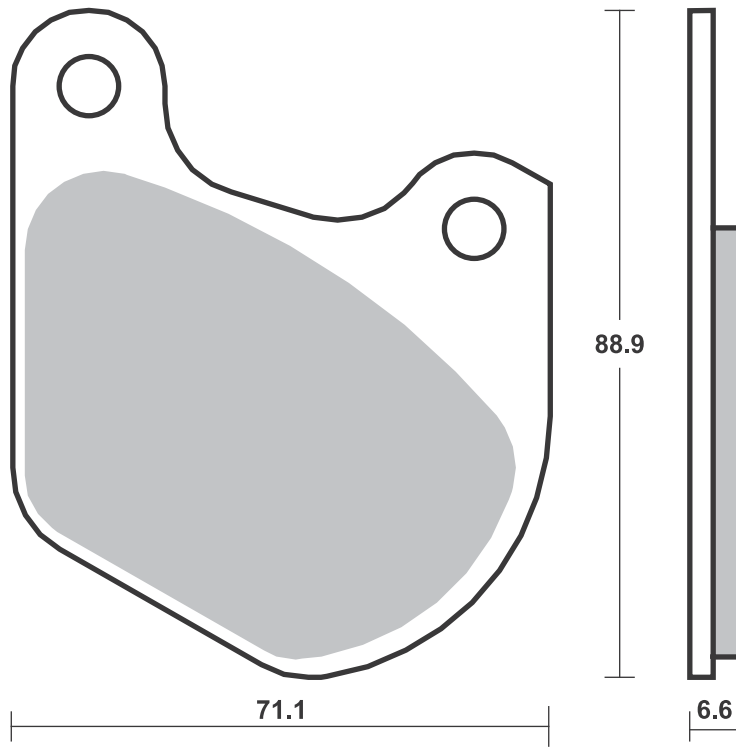

**SBS 544** Recommended compound

<b>ADLY</b>				<b>ZERO</b>			
	150 ATV	05-07	<b>SI</b>	<b>SI</b>	MX	10-12	<b>HF</b>
	150 Interceptor	05-07	<b>SI</b>	<b>SI</b>	S	ZF6.0 10-12	<b>HF</b>
	300 ATV	05-11	<b>SI</b>	<b>SI</b>	X	10-12	<b>HF</b>
					XU	11-12	<b>HF</b>
<b>APRILIA</b>							
	125 Tuono ABS	17-18					
RS-4	125 (J.Juan cal.)	11-18					<b>HF</b>
RS-4	125 Replica, ABS	16-18					<b>HF</b>
<b>BOMBARDIER</b>							
	200 Rally 2x4	03-06	<b>SI</b>				
<b>CAN-AM</b>							
DS	90 X	08-18	<b>SI</b>	<b>SI</b>			
<b>CECTEK</b>							
	500 EFI Gladiator	09-13					<b>HF</b>
	500 EFI King Cobra	09-13					<b>HF</b>
	500 EFI Quadrift	09-11					<b>HF</b>
	500 i Estoc	10					<b>HF</b>
<b>CPI</b>							
XS	250 Quad	06-08	<b>SI</b>				
<b>DERBI</b>							
DXR	200 Quad						
	(Front disc)	04-07	<b>SI</b>				
DXR	250 Quad						
	(Front disc)	04-07	<b>SI</b>				
<b>E-TON</b>							
VXL	250 Vector,						
	ST Vector	06-07	<b>SI</b>				
VTX	300 Vortex,						
	ST Vortex	07	<b>SI</b>				
VXL	300 Vector,						
	ST Vector	07-13	<b>SI</b>				
<b>HYOSUNG</b>							
GD	125 EXIV	12-16					<b>HF</b>
<b>KAWASAKI</b>							
AR	50	81-82	<b>HF</b>				
KD	80	88-90	<b>HF</b>				
KX	80	84-87	<b>SI</b>				
KX	80	88-96	<b>RSI</b>				
KX	100	88-92	<b>RSI</b>				
KX	100	95-96	<b>RSI</b>				
KX	125	82	<b>SI</b>				
KX	250	82	<b>SI</b>				
KXT	250 Tecate	84					<b>HF</b>
<b>POLARIS</b>							
	200 Phoenix	05-09	<b>ATS</b>				
	200 Sawtooth	06-07	<b>ATS</b>	<b>ATS</b>			
<b>SUZUKI</b>							
RM	80	90-95		<b>SI</b>			
RM	80	96-01		<b>RSI</b>			
RM	85 , L	02-04		<b>RSI</b>			
<b>TM</b>							
	80 Junior	96-00	<b>RSI</b>				
<b>ZERO</b>							
DS	ZF6.0	10-12					<b>HF</b>
DS	ZF9.0	10-12					<b>HF</b>

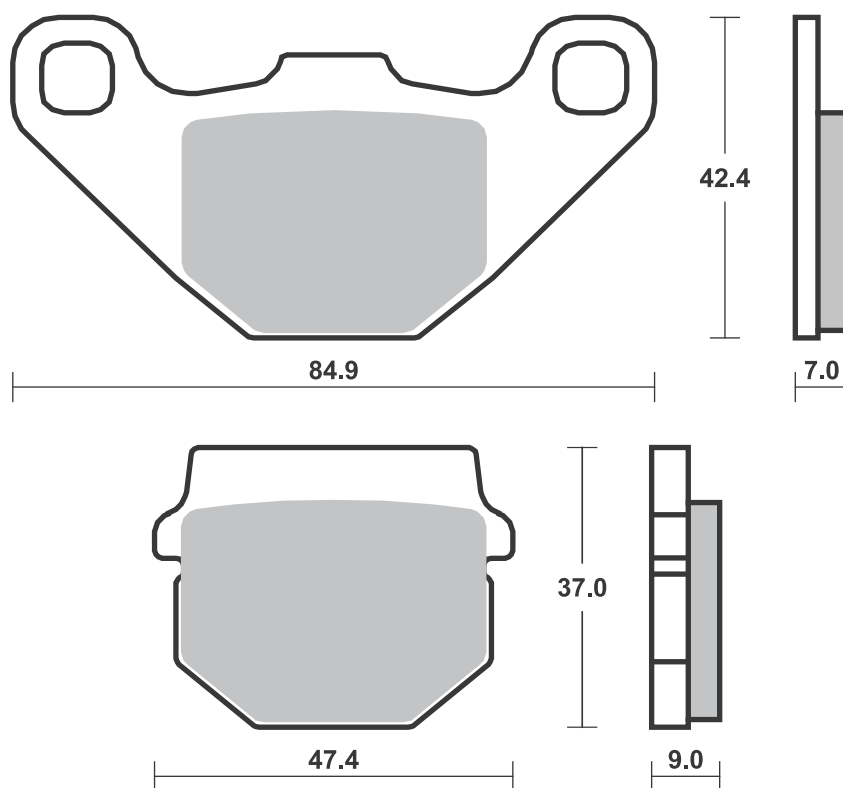





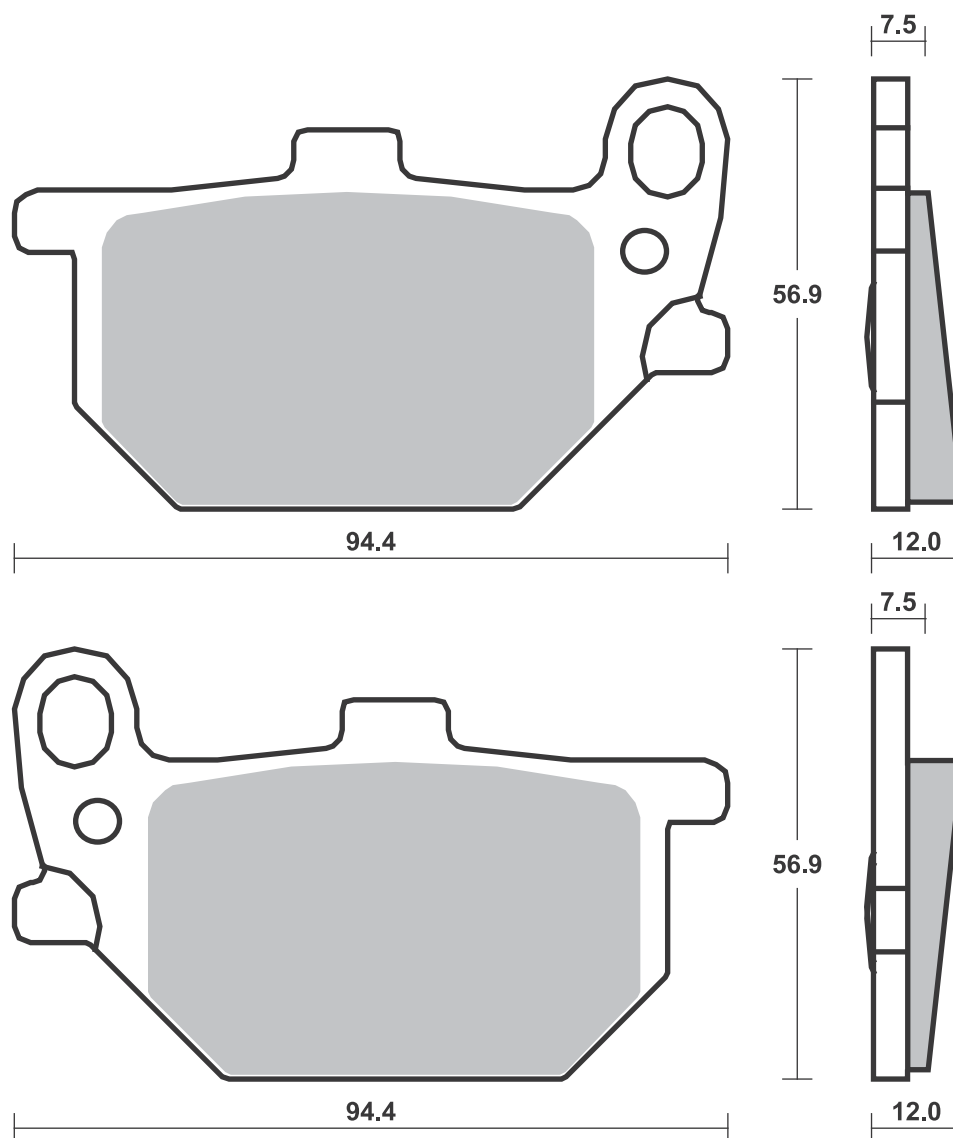



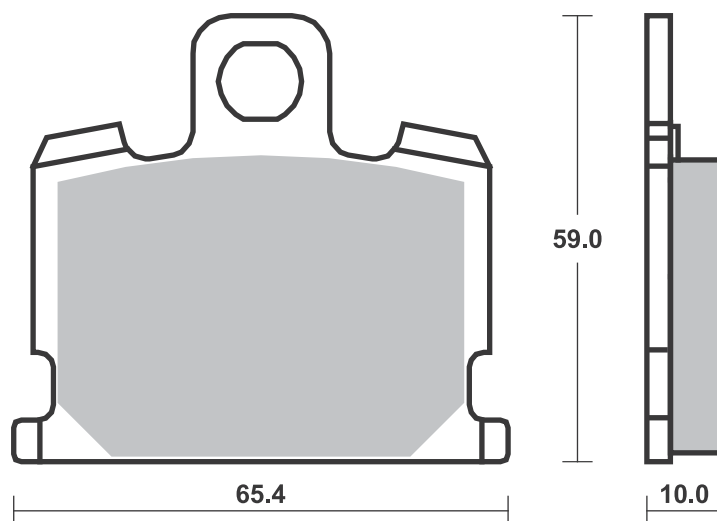
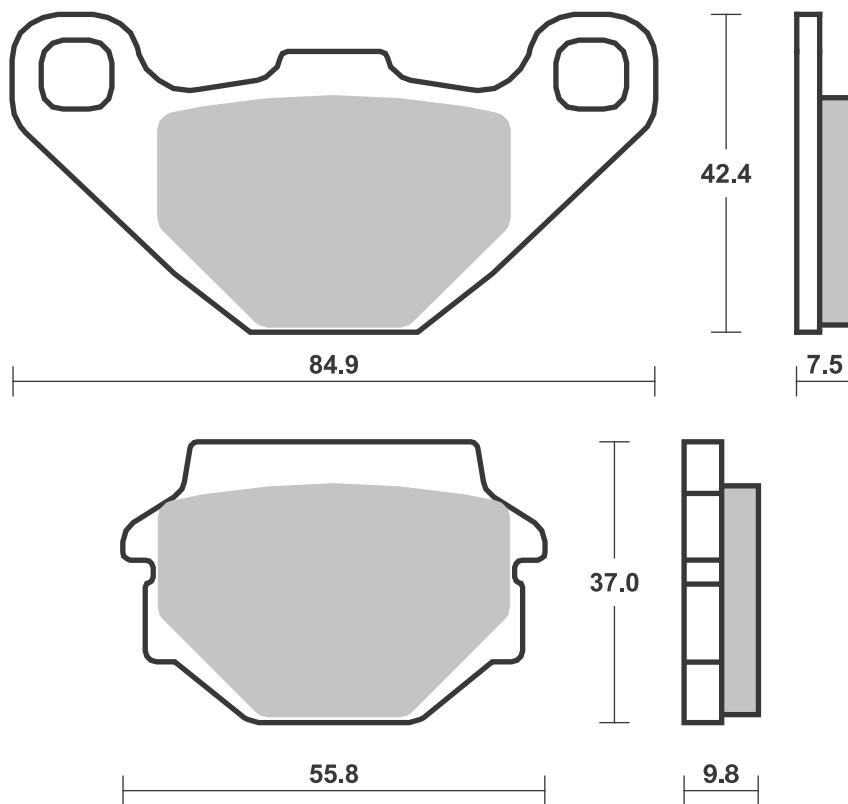



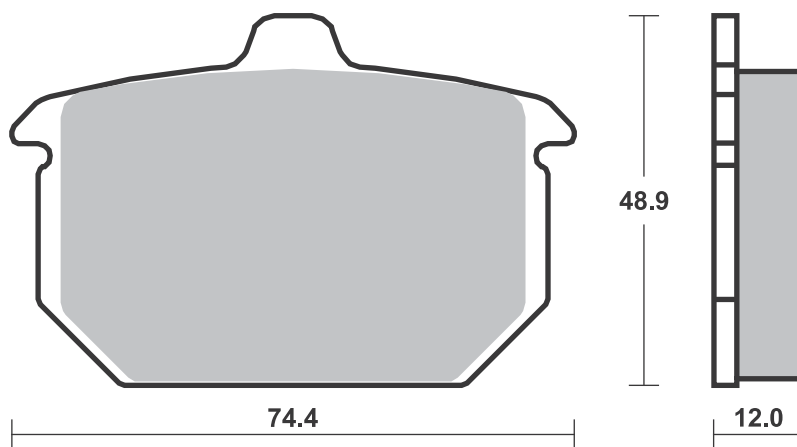
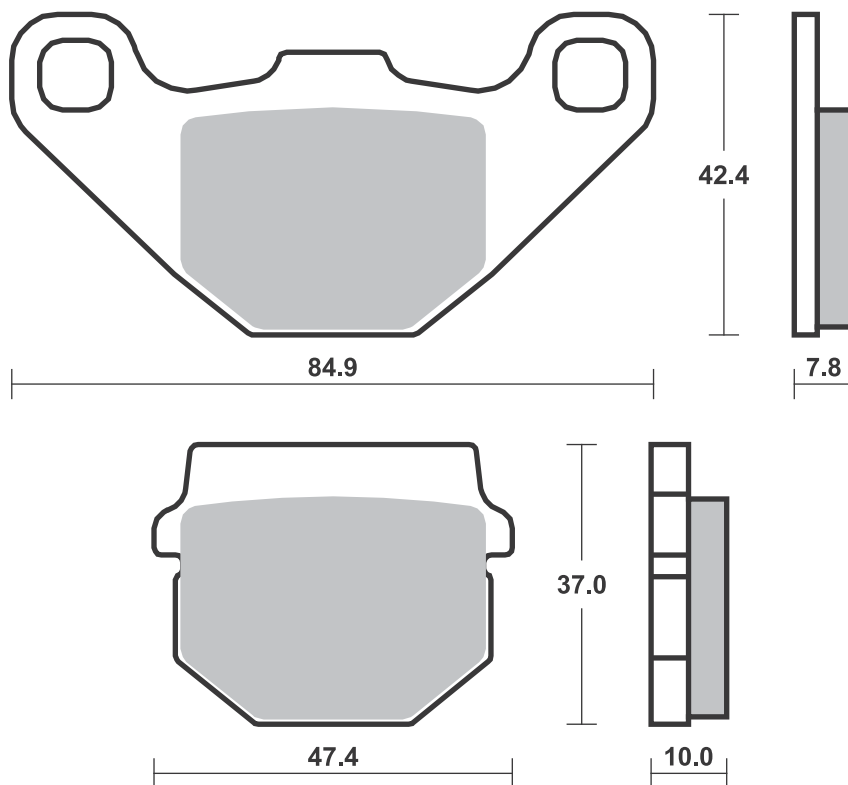





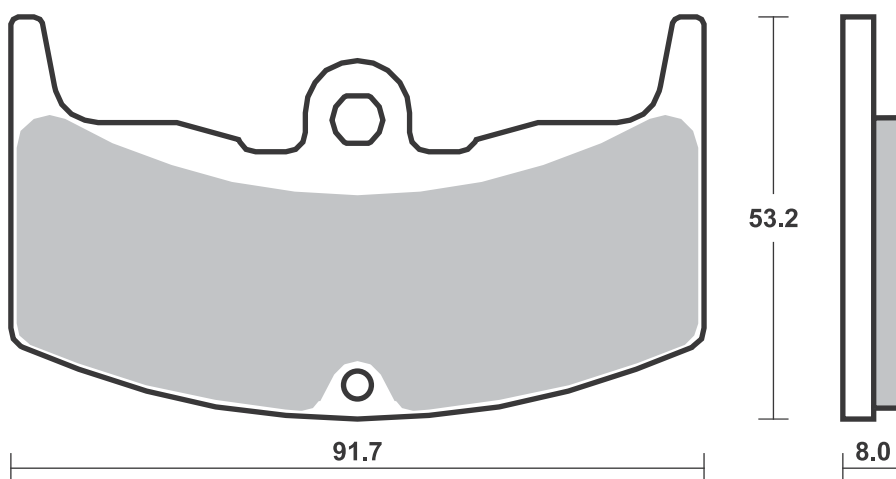
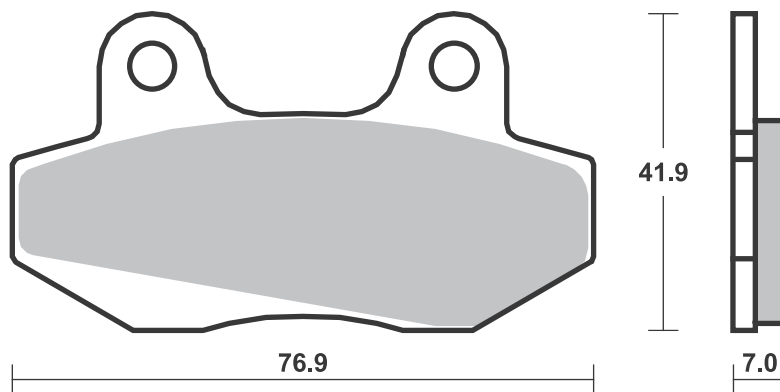
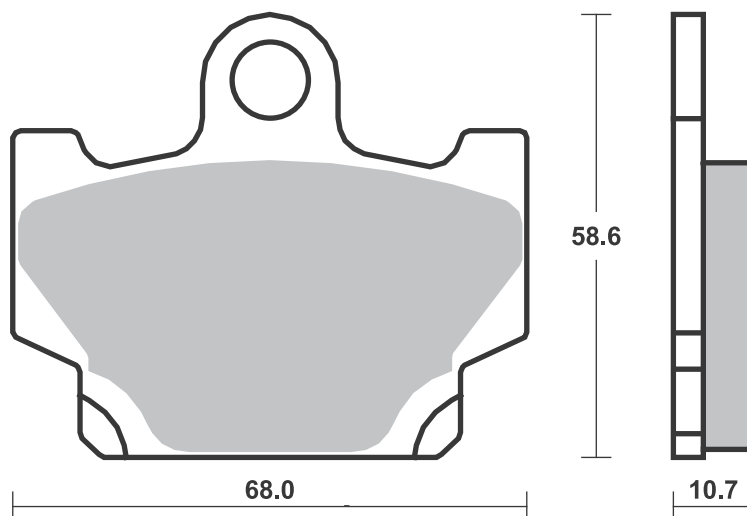



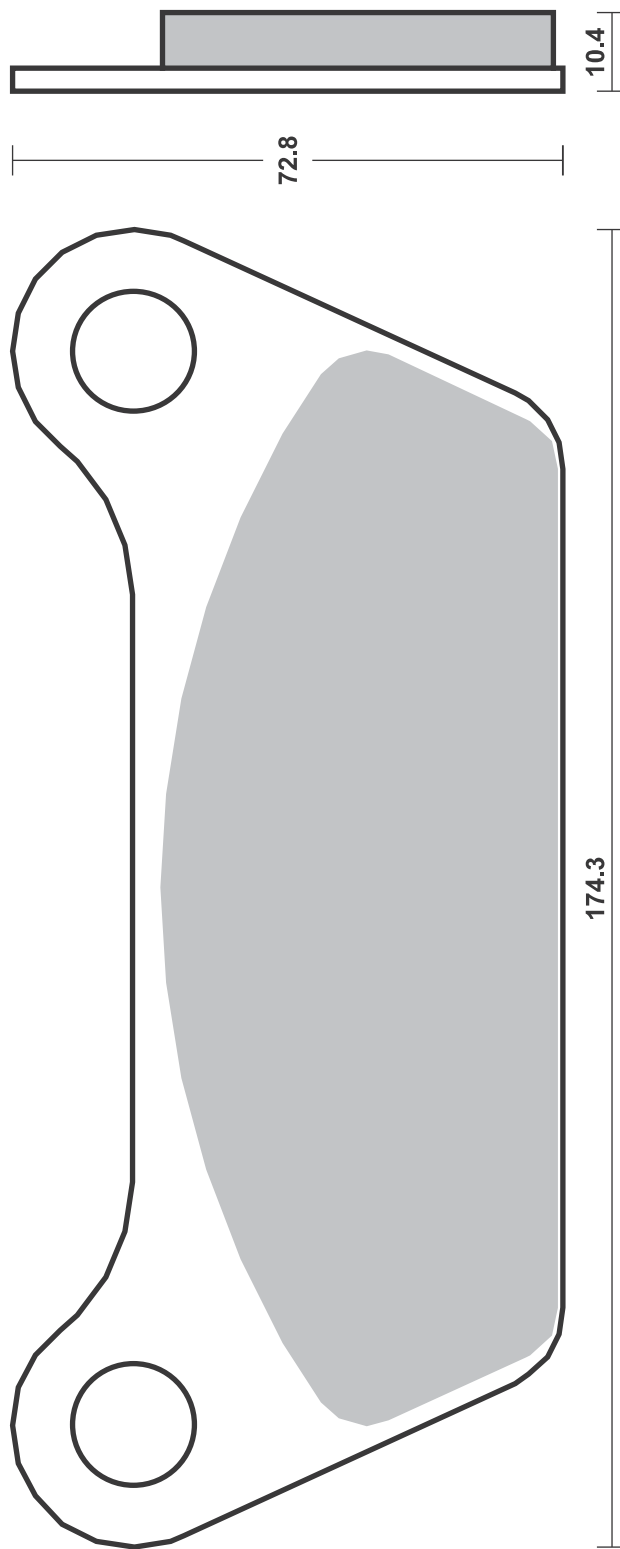



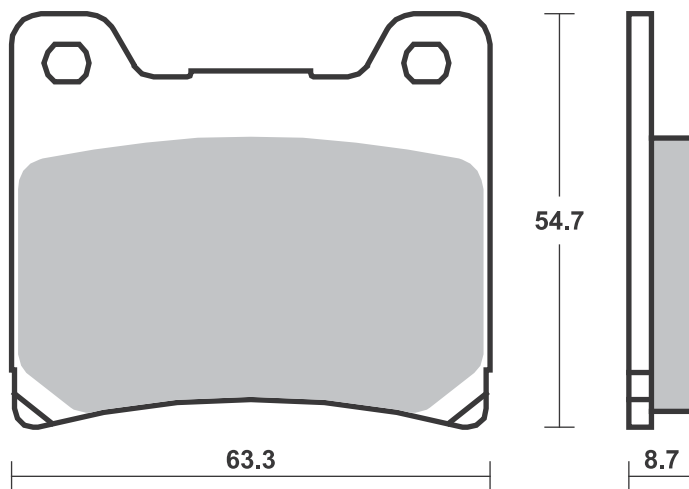
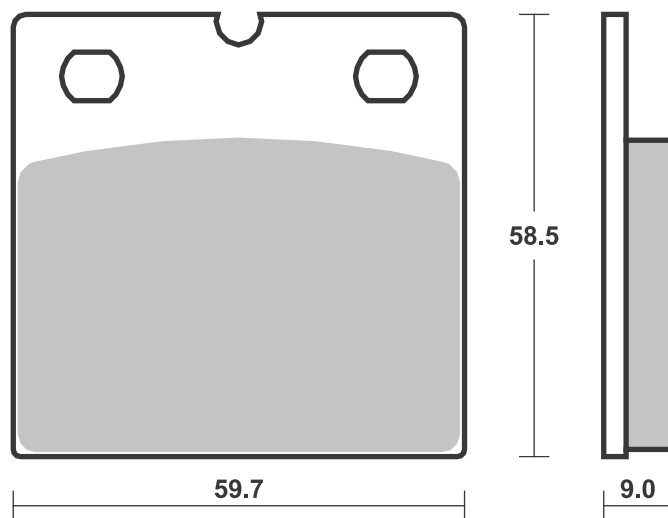

**SBS 556** Recommended compound

<b>HYOSUNG</b>			
GT	250 Comet	02	<b>LS</b>
	600 Comet	02	<b>LS</b>
<b>KAWASAKI</b>			
	600 R, Ninja	89-96	<b>HF</b>
ZX-7R	750 Ninja	89-03	<b>LS</b>
ZRX	1100	96-00	<b>LS</b>
ZX	1100	93-97	<b>LS</b>
ZZR	1100	94-01	<b>LS</b>
ZRX	1200	01-04	<b>LS</b>
ZRX	1200 R	01-08	<b>LS</b>
ZRX	1200 S	01-07	<b>LS</b>
ZX-12R	1200 Ninja	00-03	<b>LS</b>
ZX-12R	1200 Ninja	04-06	<b>LS</b>
ZZR	1200	02-04	<b>LS</b>
<b>SUZUKI</b>			
GSF	400 Bandit	91-92	<b>LS</b>
GS	500	89-03	<b>LS</b>
GS	500	04-08	<b>HF</b>
GS	500 F	04-08	<b>HF</b>
GS	550	83-86	<b>HF HF</b>
GSF	600 Bandit	95-99	<b>LS</b>
GSF	600 Bandit / S Bandit		
	Left/Rear	00-04	<b>LS</b>
GSX	600 FW Left	98-04	<b>LS</b>



<b>SUZUKI</b>			
GSX	600 Katana	88-89	<b>HF</b>
GSX	600 Katana	90-97	<b>LS</b>
GSX-R	600	92-93	<b>LS</b>
GSX-R	600	97-03	<b>LS</b>
RF	600 R	93-96	<b>LS</b>
SV	650 ,S Left/Rear	99-02	<b>LS</b>
GS	750 Katana	85-86	<b>HF HF</b>
GS	750 RF	85	<b>HF</b>
GSX	750 FW Left/Rear	98-02	<b>LS</b>
GSX	750 Katana	89-96	<b>LS</b>
GSX	750 Left/Rear	98-08	<b>LS</b>
GSX-R	750	85-87	<b>HF</b>
GSX-R	750	88-99	<b>LS</b>
GSX-R	750 Y	00-03	<b>LS</b>
TL	1000 RW	98-02	<b>LS</b>
TL	1000 S V-Twin	97-01	<b>LS</b>
GSX	1100 F	93-96	<b>LS</b>
GSX	1100 G Left/Rear	96-98	<b>LS</b>
GSX	1100 Katana	93	<b>LS</b>
GSX-R	1100	86-88	<b>HF</b>
GSX-R	1100	89-97	<b>LS</b>
GSF	1200 Bandit	95-05	<b>LS</b>
GSF	1200 S Bandit	01-05	<b>LS</b>
GSX-R	1300 Hayabusa	99-07	<b>LS</b>

**SBS 557** Recommended compound

<b>HYOSUNG</b>			
	125 GA-4	99	<b>HF</b>
GA	300	98-01	<b>HF</b>
<b>KAWASAKI</b>			
EL	250	91-94	<b>HF</b>
EL	250 Eliminator	88-89	<b>HF</b>
EX	250 R Ninja	86-87	<b>HF HF</b>
EX	305	83	<b>HF</b>
EN	450	85-90	<b>HF</b>
EN	500	90-96	<b>HS</b>
EN	500	98-04	<b>HS</b>
EN	500 Vulcan	96-97	<b>HS</b>
GPZ	550	84-87	<b>HF HF</b>
ZX	550	84-89	<b>HF HF</b>
ZL	600	85-91	<b>HF</b>
ZX	600 Ninja	85-87	<b>HF HF</b>
VN	700 Vulcan	85	<b>HF</b>
ZN	700	84-89	<b>HF HF</b>
	750 Vulcan	93-94	<b>HF</b>
GPZ	750	83-87	<b>HF HF</b>
GPZ	750 R	85-86	<b>HF HF</b>
GPZ	750 T	83-85	<b>HF HF</b>
KZ	750 , Turbo	84-86	<b>HF HF</b>
KZ	750	83-84	<b>HF</b>
KZ	750 Eliminator	88	<b>HF HF</b>
KZ	750 LTD Twin	83-85	<b>HF HF</b>
VN	750 Vulcan	86-94	<b>HF</b>
ZX	750 E, GP	83-85	<b>HF HF</b>
VN	800 Vulcan, Classic	95-97	<b>HS</b>
ZL	900 Eliminator	85-86	<b>HF HF</b>
ZX	900	83-84	<b>HF HF</b>



<b>KAWASAKI</b>			
KZ	1000 R Ninja	86-88	<b>HF HF</b>
ZG	1000 Concours	86-93	<b>HF HF</b>
ZG	1000 Concours	94-03	<b>LS</b>
ZL	1000	86-87	<b>HF HF</b>
GPZ	1100	83-86	<b>HF HF</b>
KZ	1100 GP	83-86	<b>HF HF</b>
KZ	1100 R, LTD	84	<b>HF HF</b>
ZN	1100 LTD	84	<b>HF HF</b>
ZX	1100 GP	83	<b>HF HF</b>
ZG	1200 Voyager XII	86-93	<b>HS LS</b>
ZN	1300	83-84	<b>HF HF</b>
ZN	1300 Voy.	85-86	<b>HF HF</b>
VN	1500 Vulcan	87-92	<b>HS LS</b>
VN	1500 Vulcan Classic	97-99	<b>LS</b>
VN	1500 Vulcan Nomad		
	Left/Rear	98-01	<b>LS</b>
VN	1500 Vulcan, SE	87-92	<b>HS LS</b>



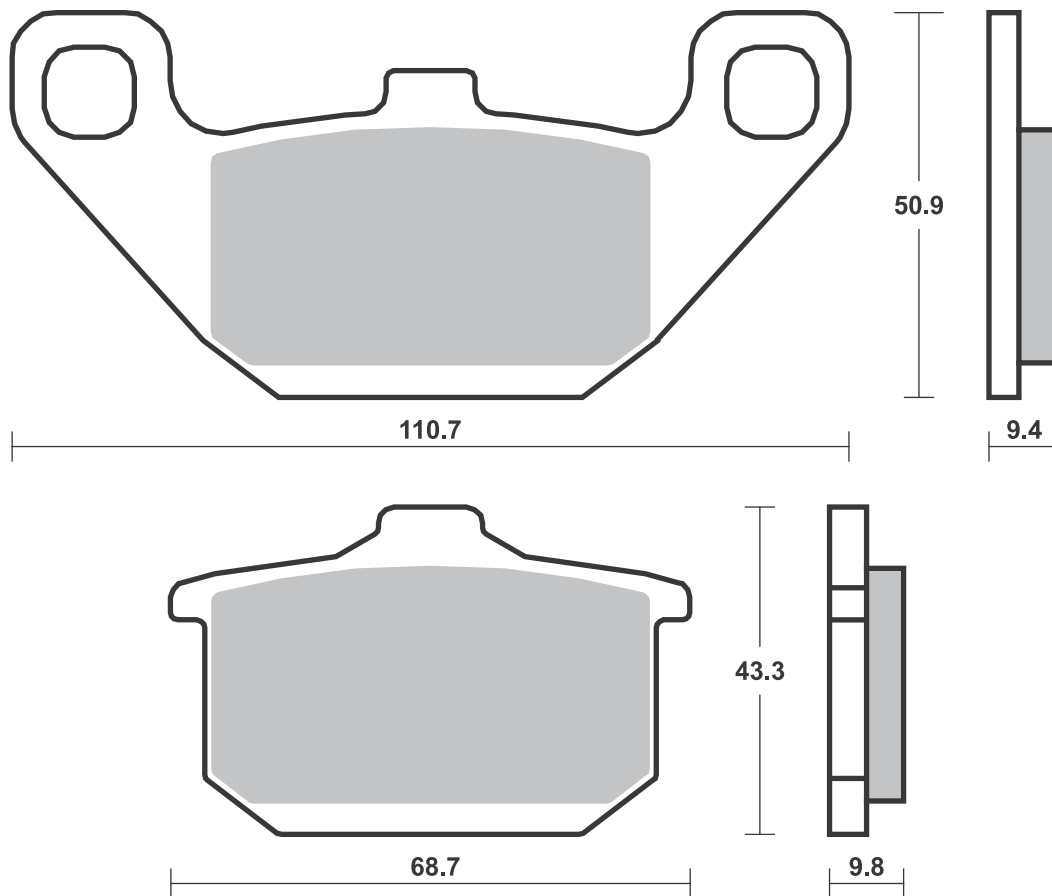
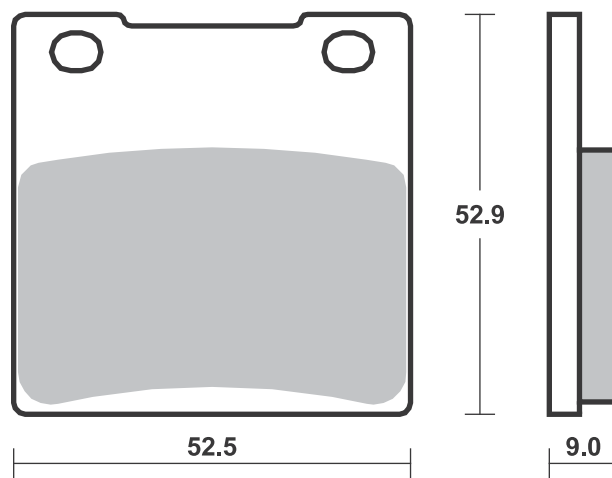

**SBS 558** Recommended compound

<b>BENELLI</b>			
TNT	125	17	HF
<b>HONDA</b>			
CR	125 RE, RF	84-85	SI
CR	125 RG	86	SI
ATC	250 R	85-86	SI SI
ATC	250 X	85	SI
CR	250 RE, RF	84-85	SI
CR	250 RG	86	SI
MTX	250 R	86	SI
TRX	250 R	86-89	SI
TRX	250 R Fourtrax	88	SI
TRX	250 X Fourtrax	87	SI
XL	250 R	84-87	HF
XR	250 R	84-87	SI
ATC	350 Odyssey	85	SI
ATC	350 X	85	SI



<b>HONDA</b>			
XL	350 R	84-87	HF
XR	350 R	84-85	SI
CR	500 RE, RF	84-85	SI
CR	500 RG	86	SI
XL	500 R	83-87	HF
XR	500 R, Pro Link	83-84	HF
XL	600 R	83-86	HF
XR	600 R	83-87	SI

**SBS 559** Recommended compound

<b>ATK</b>			
ATK	560	87-88	HF
<b>BETA</b>			
	50 Rev	00-09	HF HF
ST	50	97	HF HF
	80 EVO Junior	10-11	HF HF
	80 Rev	00-07	HF HF
ALP	125	99-09	RSI RSI
ALP	125 4-stroke	00-05	RSI RSI
SR	125 34	89	HF
TR	125 34,35	89-90	RSI RSI
TRIAL	125	97	RSI
ALP	200 4-stroke	00-05	RSI RSI
	240 Super Trial	92	RSI
ALP	240	92	RSI
ALP	240	96	RSI
	250 Techno	96	RSI RSI
	250 Zero	91	RSI
ALP	250	92	RSI
ALP	250	97-03	RSI RSI
	260 Zero	91	RSI
ALP	260	96	RSI
TR	260 34,35,ZERO	89-92	RSI
<b>CPI</b>			
	125 Supermoto	07-12	HF
<b>DERBI</b>			
DS	50	88	HF
FD	50 Yumbo	84	HF
FD	50 Yumbo Extra	87	HF
FDS	50	87	HF
FDT	50	87-85	HF
FDT	50 Coppa	85	HF
FDX	50	89	HF
GP1	50	05	HF
GPR	50 Nude	04-10	HF
GPR	50 Racing	04-13	HF
	75 GPR	89	HF
	75 Sport, Coppa	84	HF
GPR	75 Sport	92	HF
GPR	80 Cup	04-05	HF



<b>DERBI</b>			
	125 Senda R 4T	04-12	HF
	125 Senda		
	X-Treme		
	SM 4T	04-05	HF
	125 Terra	07	HF
GP1	125	05-06	HF
GPR	125	05-06	HF
GPR	125 Nude	05-08	HF
GPR	125 Racing	09	HF
<b>FANTIC</b>			
	250 K-Roo	93-95	RSI RSI
	305	89-90	RSI RSI
	307 Trial	91-94	RSI RSI
<b>GAS GAS</b>			
TXT	50 Boy	04	RSI RSI
	125 Delta	91	HF
	125 Pampera	96-03	RSI RSI
	125 Trial	91	RSI
	200 Pampera	99-08	RSI RSI
TX	200	97-98	RSI RSI
	250 Pampera	96-99	RSI RSI
	250 Trial	89-96	RSI RSI
GT	250 Contact	92-93	RSI RSI
TX	270	97-98	RSI RSI
TX	320	97-99	RSI RSI
	325 Halley PXC	86	RSI RSI
	327 Trial	89-90	RSI RSI
GT	327 Contact	89-90	RSI RSI
	370 Pampera	96-00	RSI RSI
<b>GMA</b>			
	4 Piston front Model F		
<b>HUSQVARNA</b>			
	50 Husky Boy J,		
	R, S	01-10	RSI
<b>JAYBRAKE</b>			
	2 Piston Dual Series		
	Caliper		



<b>JAYBRAKE</b>			
	4 Piston Quad Series		
	Caliper		
<b>KTM</b>			
SX	60	99	RSI
SX	65	00-01	RSI
<b>MALAGUTI</b>			
	50 Fifty Evolution	91	HF
<b>PERFORMANCE MACHINE</b>			
	125 X 2		
	125 X 4S		
	125 X 4SL		
<b>SCORPA</b>			
TY-S	115 F Trial	06	HF
TY-S	125 F Trial	06-08	HF
<b>SHERCO</b>			
	80 0.8	01-03	HF HF
ST	125 1.25	01-05	HF HF
ST	200 2.0	01	HF HF
ST	250	99-00	RSI RSI
<b>SJP</b>			
	2 Piston Caliper (30-375)		
	4 Piston Caliper (30-370)		
<b>TOMOS</b>			
MC	125 T	06-08	HF
SE	125	05-08	HF
SM	125 F	06-08	HF
<b>YAMAHA</b>			
TY	250 R	91-92	HF
TY	250 Z	93-96	HF HF

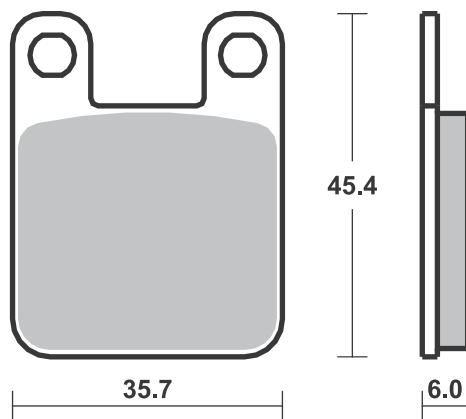
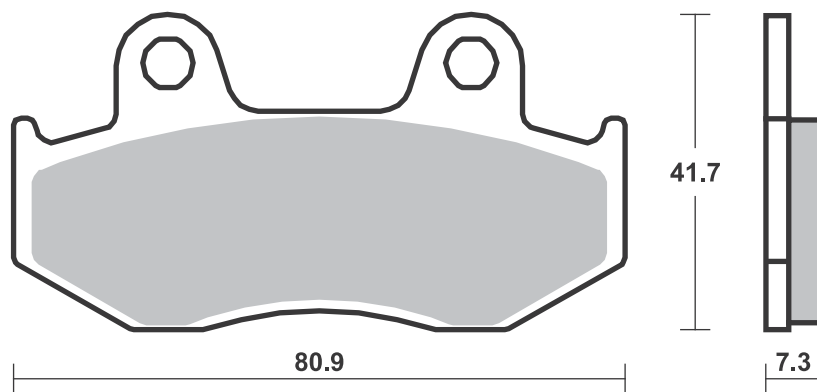

**SBS 560** Recommended compound



<b>CAGIVA</b>			
650 Alazzurra	85- 88	<b>HF</b>	<b>HF</b>
<b>FANTIC</b>			
HP1 125 Sport	86	<b>HF</b>	
<b>GILERA</b>			
80 TG 1, 2, 3	77- 82	<b>HF</b>	
125 TG 1, 2, 3 (alu wheels)	77- 85	<b>HF</b>	
125 TG1, GR1, RTX	77- 85	<b>HF</b>	
RV 200	85- 86	<b>HF</b>	
<b>GMA</b>			
2 Piston Caliper, small Model B			



<b>JAYBRAKE</b>			
2 Piston Caliper ADC/ADCS			
<b>MOTO-MORINI</b>			
125 Strada	80	<b>HF</b>	
250 Strada	80	<b>HF</b>	
350 K2	84- 87	<b>HF</b>	
350 Strada	76- 81	<b>HF</b>	
500 Strada	80- 82	<b>HF</b>	

**SBS 561** Recommended compound



<b>HONDA</b>			
CB 450 SC Nighthawk	82	<b>HF</b>	
CB 650 SCC Nighthawk	82	<b>HF</b>	
VT 700 C Shadow	84- 86	<b>HF</b>	
VT 750 C	83- 85	<b>HF</b>	

**SBS 562** Recommended compound



<b>HONDA</b>			
ATC 200 X	83- 85		<b>SI</b>
ATC 250 R	82- 84		<b>SI</b>
ATC 250 X	85		<b>SI</b>
TRX 300 EX	93- 00		<b>SI</b>
ATC 350 Odyssey	85		<b>SI</b>
ATC 350 X	85- 89		<b>SI</b>

Brake Pad 1:1 Drawings,  
Compounds, Fitments

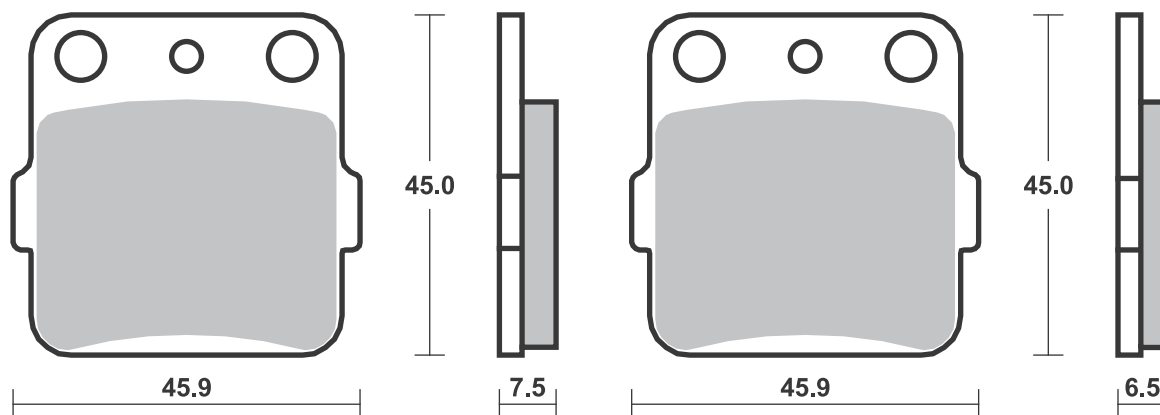
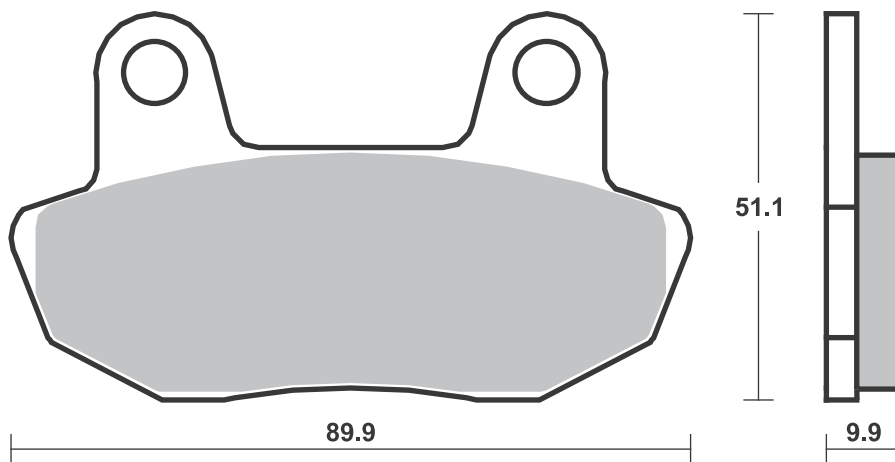
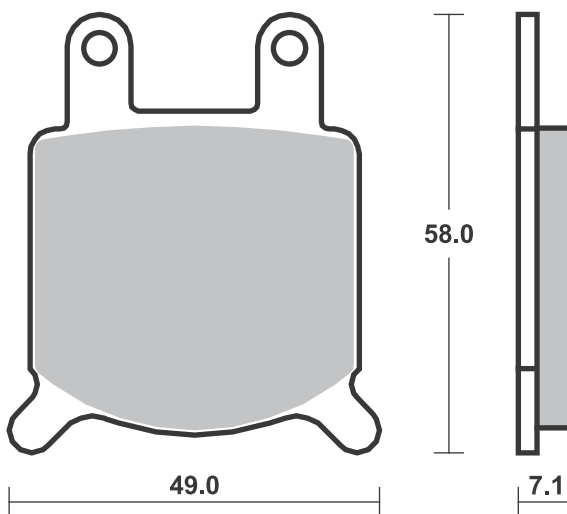



<b>APRILIA</b>			
RS-4	125 (J.Juan cal.)	11-18	<b>HS</b>
<b>BETA</b>			
	350 4.0 Motard	04-06	<b>RSI</b>
<b>BIMOTA</b>			
YB7	400	89	<b>HF</b>
	500 Vdue	97-00	<b>HF</b>
	600 Bellaria	91	<b>HF</b>
YB9	600 SRI	97	<b>HF</b>
BB1	650 Supermono	97-00	<b>HF</b>
SB7	750	96-88	<b>HF</b>
YB4	750	89	<b>HF</b>
1D	851 Tesi	91	<b>HF</b>
1D	900 Tesi	93	<b>HF</b>
DB2	900	92-00	<b>HF</b>
DB3	900 Mantra	97-00	<b>HF</b>
1D	906 Tesi	91	<b>HF</b>
	1000 Furano	92-93	<b>HF</b>
2D	1000 Tesi	04-06	<b>HS</b>
YB11	1000	97-00	<b>HF</b>
YB6	1000	89	<b>HF</b>
YB8	1000	90	<b>HF</b>
	1002 Dieci	91	<b>HF</b>
SB6	1100	97-00	<b>HF</b>

**BREMBO RACING CALIPERS**

Billet 20.4756.52/62,  
racing  
Goldline single  
pin 20.5165.55/65, road

**CAGIVA**

	125 Raptor	03-10	<b>HF</b>
	500 Mito	07	<b>HS</b>
SP	525 Mito	08-10	<b>HS</b>

**CANNONDALE**

S	440	03	<b>HF</b>
---	-----	----	-----------

**DUCATI**

	400 SS, Junior	92-97	<b>HF</b>
	400 SS, Nuda	92-96	<b>HF</b>
	502 Single	93	<b>HF</b>
	502 Supermono	93	<b>HF</b>
	600 SS Supersport	95-00	<b>HF</b>
M	600 Monster	94-99	<b>HF</b>
	748 Biposto	95-98	<b>HF</b>
	748 SP	95-97	<b>HF</b>
	750 Monster	96-99	<b>HF</b>
	750 SS	91-98	<b>HF</b>
	750 SS Supersport	95-99	<b>HF</b>
	750 SS, Carenara	92-98	<b>HF</b>
	750 SS, Nuda	92	<b>HF</b>
	750 Super Sport	92-94	<b>HF</b>
	851 Strada	89	<b>HF</b>
	851 Strada	91-92	<b>HF</b>
	851 Superbike	90	<b>HF</b>
	888 Roche Replica	91	<b>HF</b>
	888 SP V	93	<b>HF</b>
	888 SP4	92-95	<b>HF</b>
	888 SPO	93	<b>HF</b>
	888 SPS	92-95	<b>HF</b>
	888 Strada	93	<b>HF</b>
	888 Superbike	93	<b>HF</b>
	900 FE	97-98	<b>HF</b>
	900 M, IL Monster	93-99	<b>HF</b>



<b>DUCATI</b>			
	900 SL	92-97	<b>HF</b>
	900 SS	90-94	<b>HF</b>
	900 SS Supersport	95-97	<b>HF</b>
	900 SSR	92	<b>HF</b>
907	900 I. E.	90-93	<b>HF</b>
M	900 Street Monster	94-99	<b>HF</b>
	916 Biposto	94	<b>HF</b>

**GAS GAS**

SM	125	02-13	<b>HF</b>
SM	250	02-13	<b>HF</b>
SM	400 fse	02	<b>HF</b>
SM	450 fse	03-06	<b>HF</b>
SM	450 FSR	07-13	<b>HF</b>

**GILERA**

	350 Saturno		
	Bialbero	90	<b>HF</b>
	500 Saturno		
	Bialbero	90	<b>HF</b>
	500 Saturno		
	Piuma	90-94	<b>HF</b>

**HONDA**

RS	125	95-03	<b>#DC</b>
RS	250 R	93	<b>#DC</b>

**HUSQVARNA**

SM	400 R	02	<b>HF</b>
SM	450 R	03-04	<b>HF</b>
SM	570 R	01-08	<b>HF</b>

**INDIAN**

	1700 Chief		
	Blackhawk	11-13	<b>H.HS</b>
	1700 Chief Bomber	10-13	<b>H.HS</b>
	1700 Chief Classic	10-13	<b>H.HS</b>
	1700 Chief Dark		
	Horse	10-13	<b>H.HS</b>
	1700 Chief Deluxe	09-13	<b>H.HS</b>
	1700 Chief		
	Roadmaster	09-13	<b>H.HS</b>
	1700 Chief Standard	09-13	<b>H.HS</b>
	1700 Chief Vintage	09-13	<b>H.HS</b>

**ITALJET**

	900 Grifon	00	<b>HF</b>
--	------------	----	-----------

**KTM**

	125 Sting	99	<b>HF</b>
SX	450 SM Factory		
	Replica	04-07	<b>RSI</b>
	600 Duke	93-94	<b>HF</b>
	620 Duke	96-98	<b>HF</b>
	640 Duke	99-02	<b>HF</b>
LC4	640 Supermoto	03	<b>HF</b>
LC4	660 SM Factory		
	Replica	02	<b>RSI</b>
SMC	660 Supermoto	03	<b>HF</b>

**LAVERDA**

	650	92	<b>HF</b>
	668 668	96-97	<b>HF</b>
	668 Ghost,		
	Diamante	97	<b>HF</b>
	750 Cup	98-01	<b>HF</b>
	750 Diamante	97-01	<b>HF</b>



<b>LAVERDA</b>			
	750 Ghost Strike	97-01	<b>HF</b>
	750 S Formula	97-01	<b>HF</b>
	750 S, S Carenata	97-01	<b>HF</b>
	750 Sport	99-01	<b>HF</b>
	750 Strike/Black		
	Strike	99-01	<b>HF</b>
	750 T8	98-01	<b>HF</b>
TTS	800	99	<b>HF</b>
JOTA	1000	95	<b>HF</b>

**MOTO-GUZZI**

	750 Ippogrifo	97	<b>HF</b>
	1000 Daytona	91-02	<b>HF</b>
	1000 Quota	92	<b>HF</b>
RS	1000 Daytona	97-00	<b>HF</b>
V10	1000 Centauro	96-00	<b>HF</b>
	1100 California		
	Jackal	00	<b>HF</b>
	1100 California		
	Jackal Basic	00	<b>HF</b>
	1100 California		
	Special	99-00	<b>HF</b>
	1100 Sport	96-04	<b>HF</b>
EV	1100 California	97-00	<b>HF</b>
V11	1100 Sport	97-00	<b>HF</b>

**MZ**

	660 (MUZ)		
	Skorpion Cup	99	<b>HF</b>
	660 (MUZ)		
	Skorpion		
	Replica	97-99	<b>HF</b>
	660 (MUZ)		
	Skorpion Sport	95-99	<b>HF</b>
	660 (MUZ)		
	Skorpion Tour	95-00	<b>HF</b>
	660 (MUZ)		
	Skorpion		
	Traveller	99-00	<b>HF</b>

**NORTON**

F-1	600	90	<b>HF</b>
TT	600	92	<b>HF</b>

**REVTECH**

Wilwood Caliper front/rear

**SACHS**

	500 MadAss	05-08	<b>HF</b>
--	------------	-------	-----------

**TM**

SMR	125	05	<b>RSI</b>
SMF	400 F	02	<b>RSI</b>
SMR	400 F	03	<b>RSI</b>
SMR	450 F	04	<b>RSI</b>
SMX	450 F	03	<b>RSI</b>
SMR	530 F	03	<b>RSI</b>
SMX	600 F	03	<b>RSI</b>

**VOR**

SM	400	02	<b>RSI</b>
SM	450	02-04	<b>RSI</b>
	500 492 Super		
	Motard	00-01	<b>HF</b>
SM	530	02-04	<b>RSI</b>



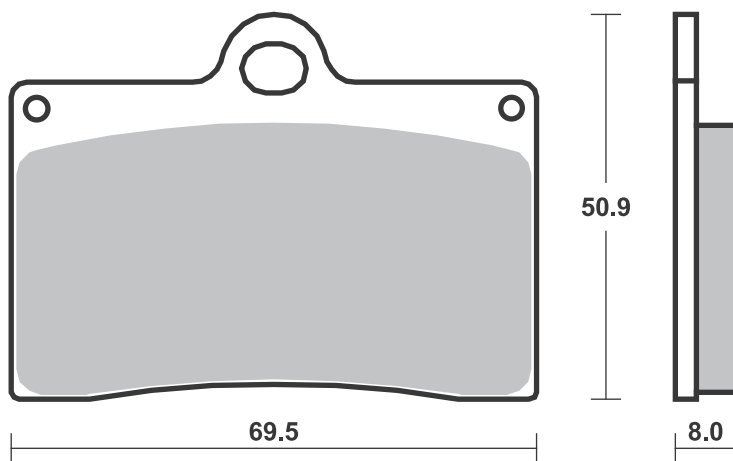



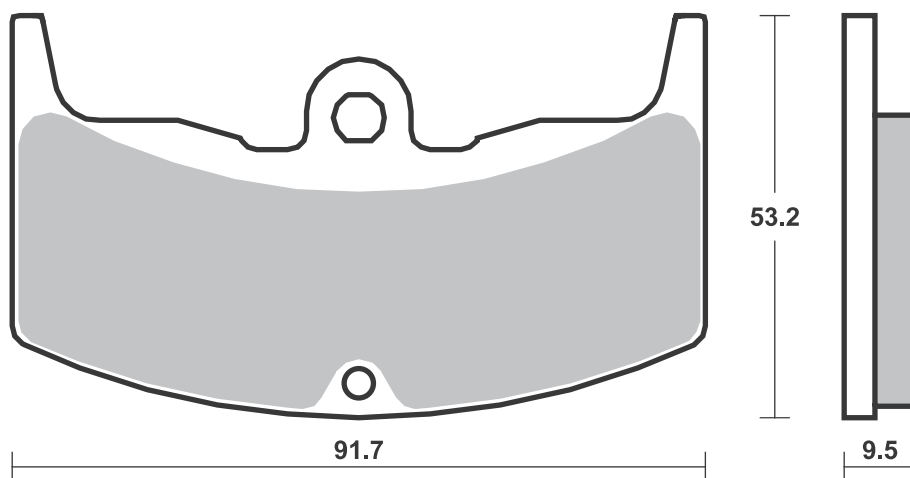
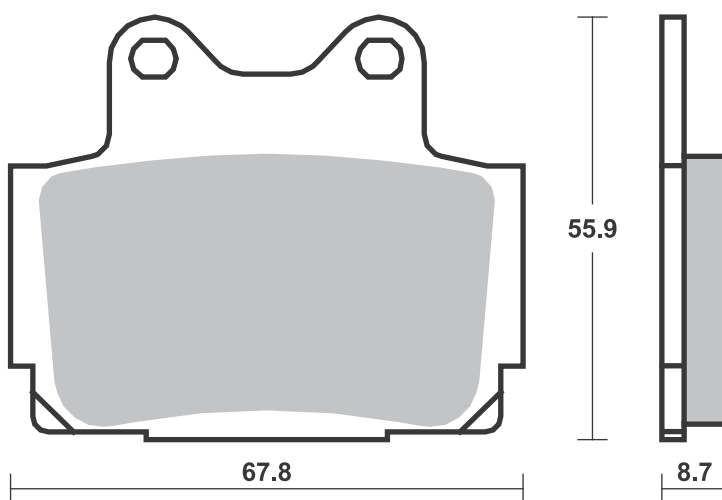
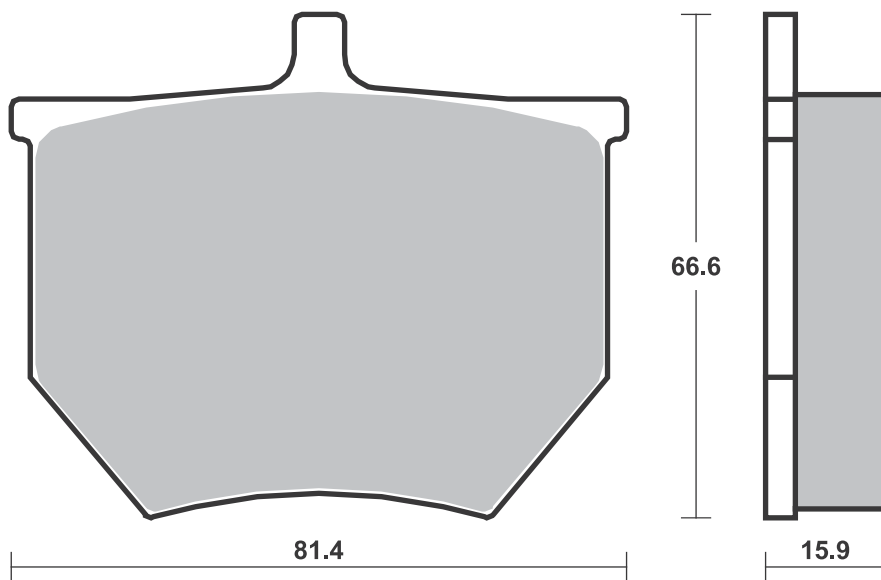



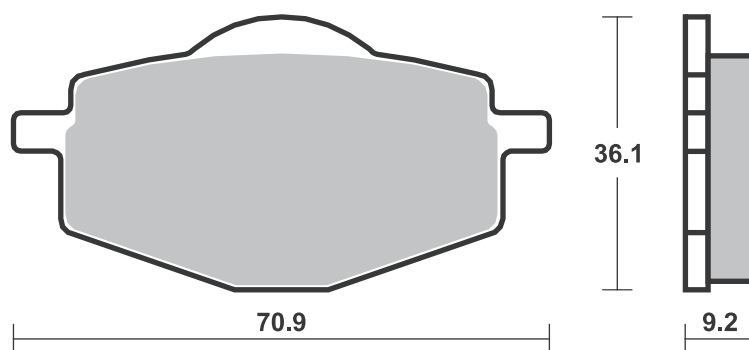
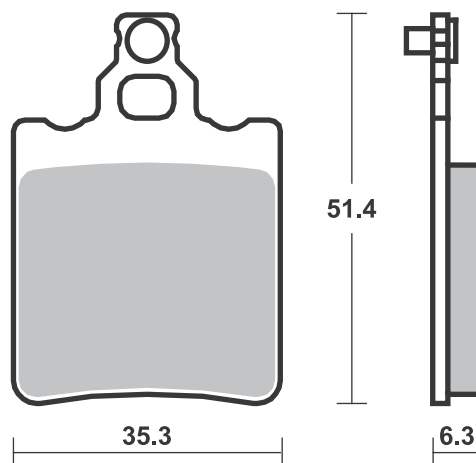
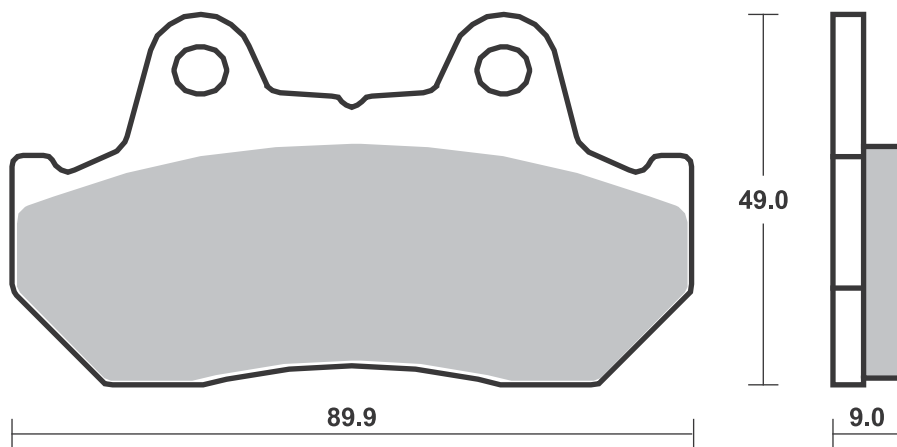



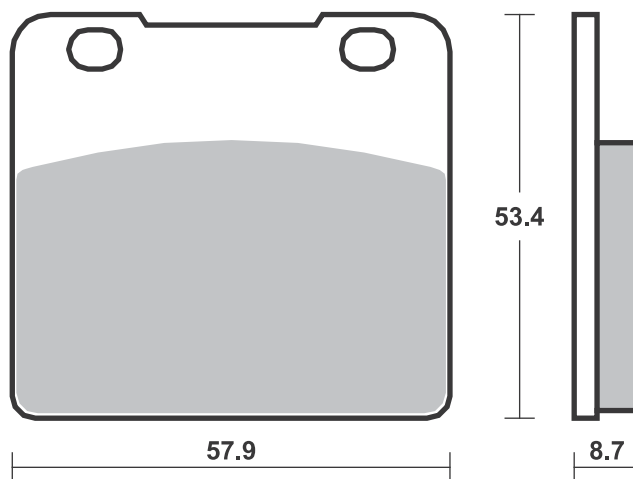
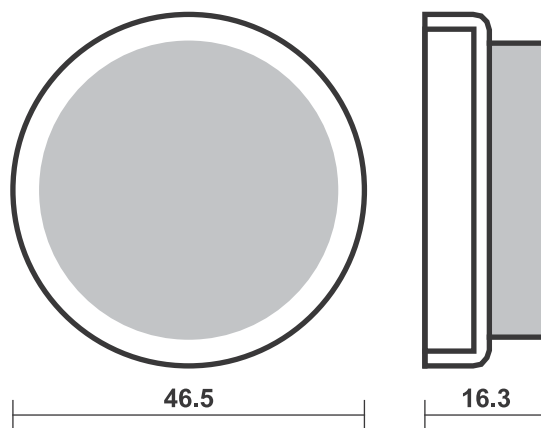





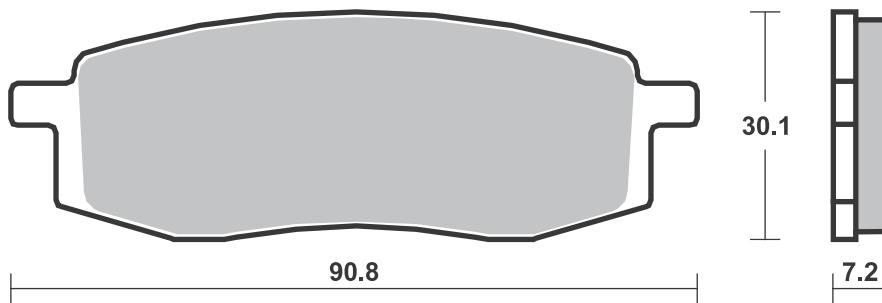
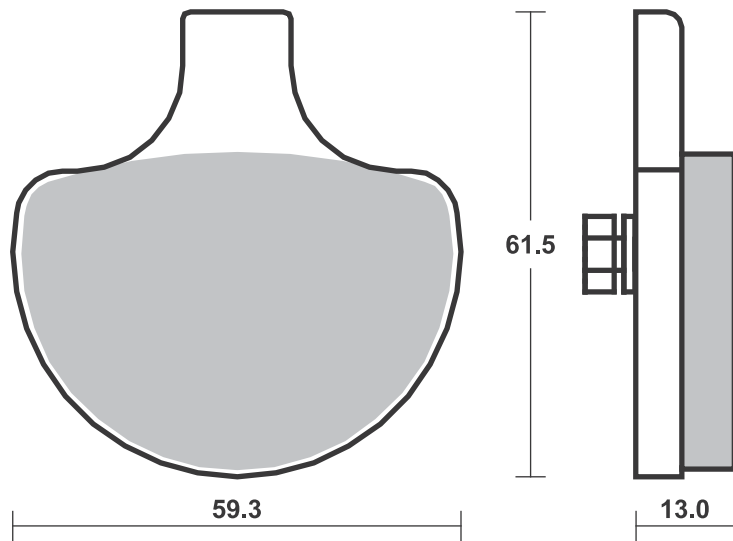
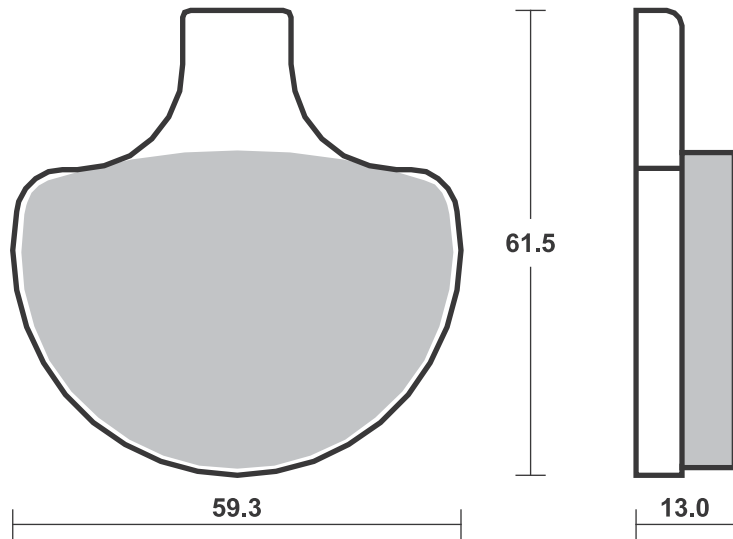



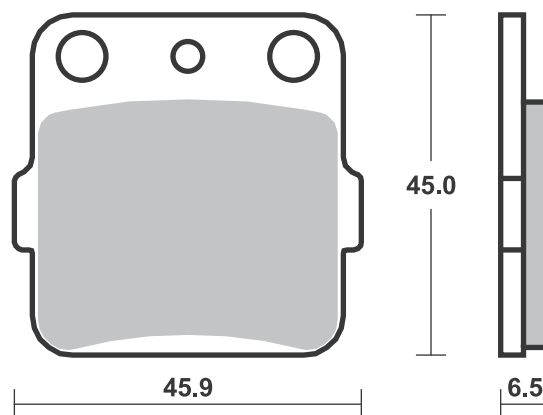
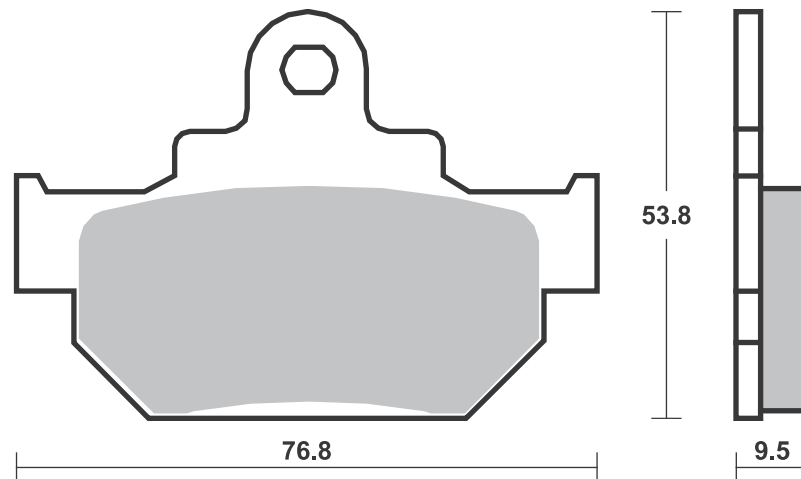
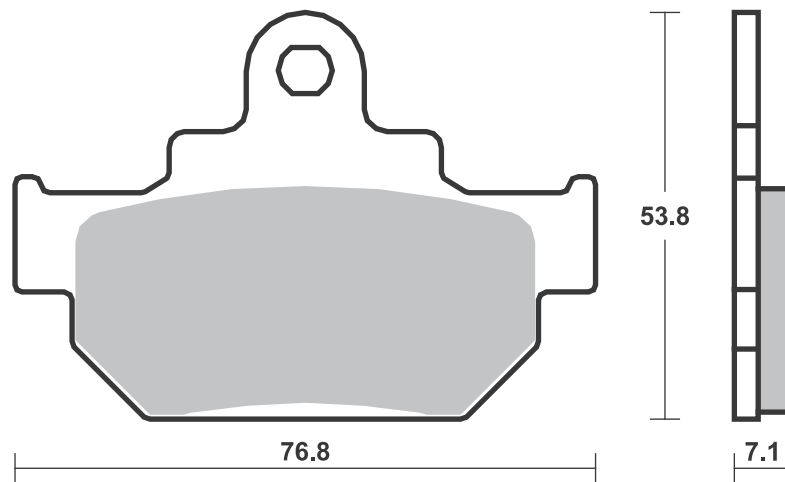



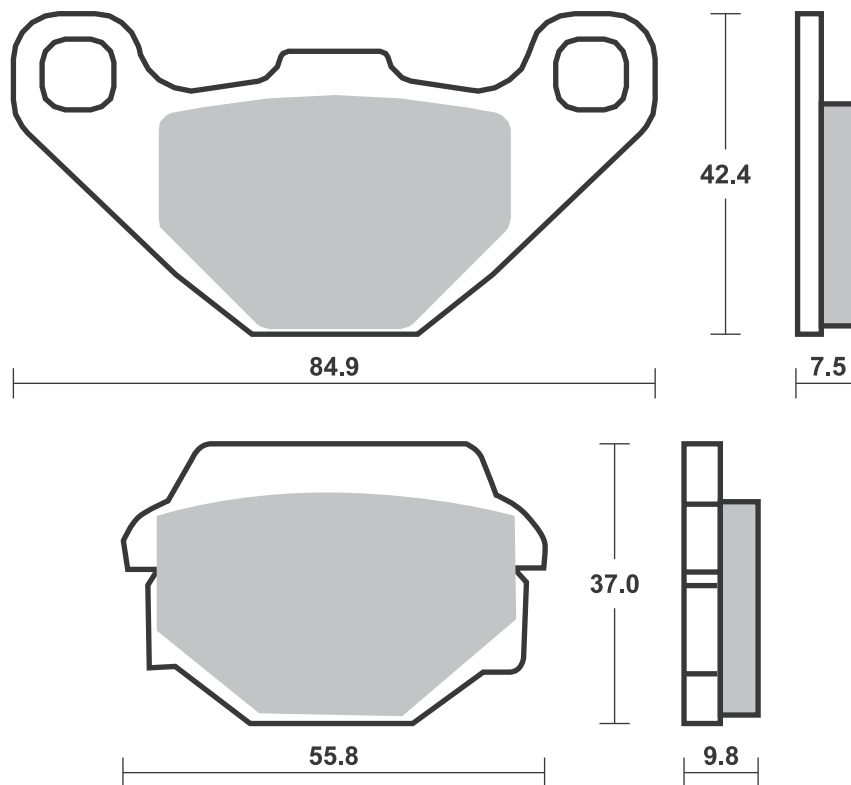
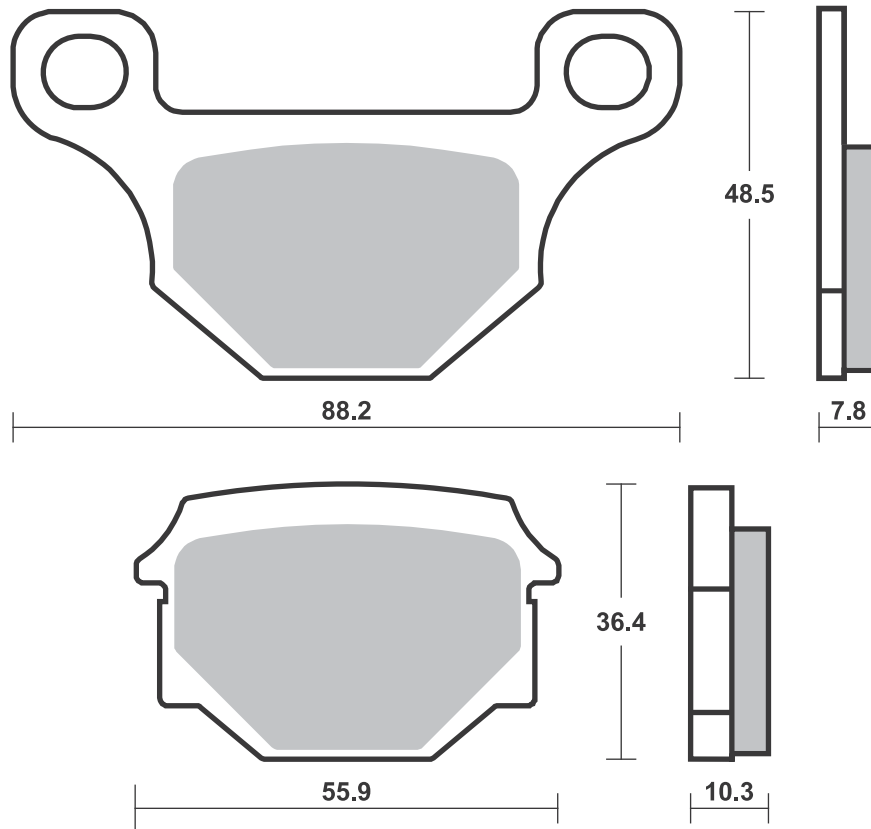





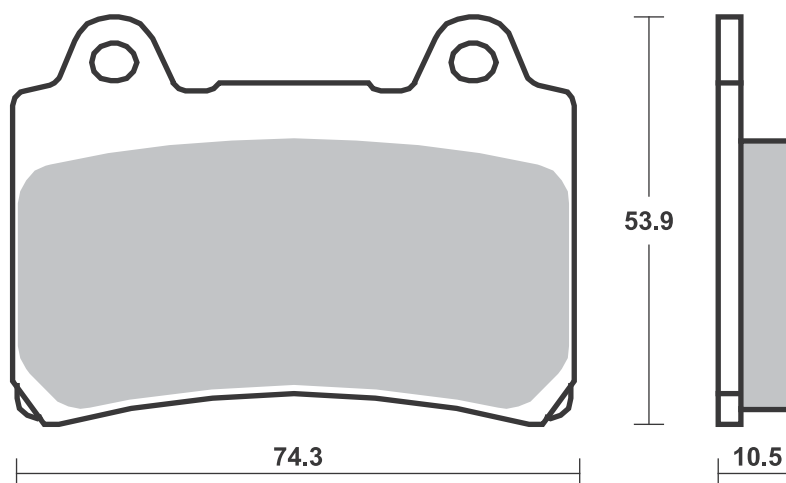
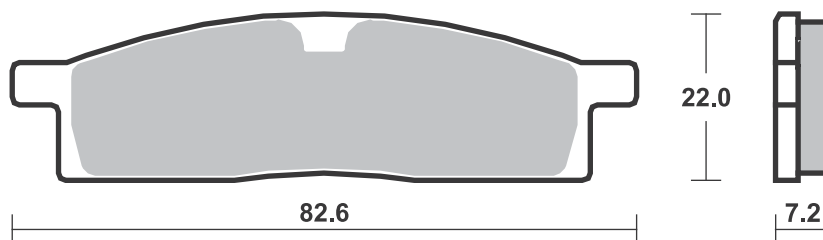
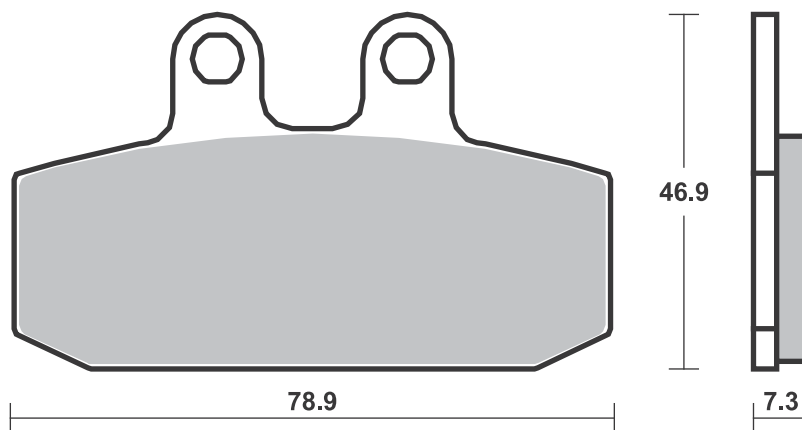



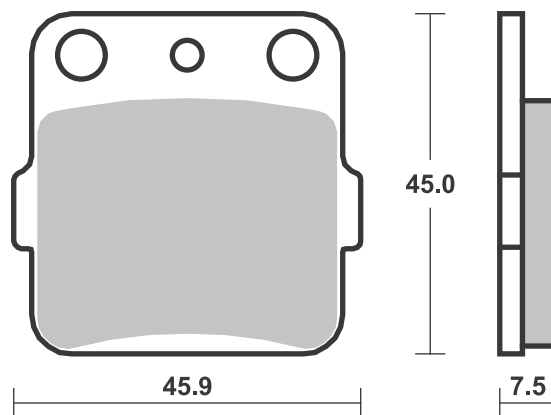
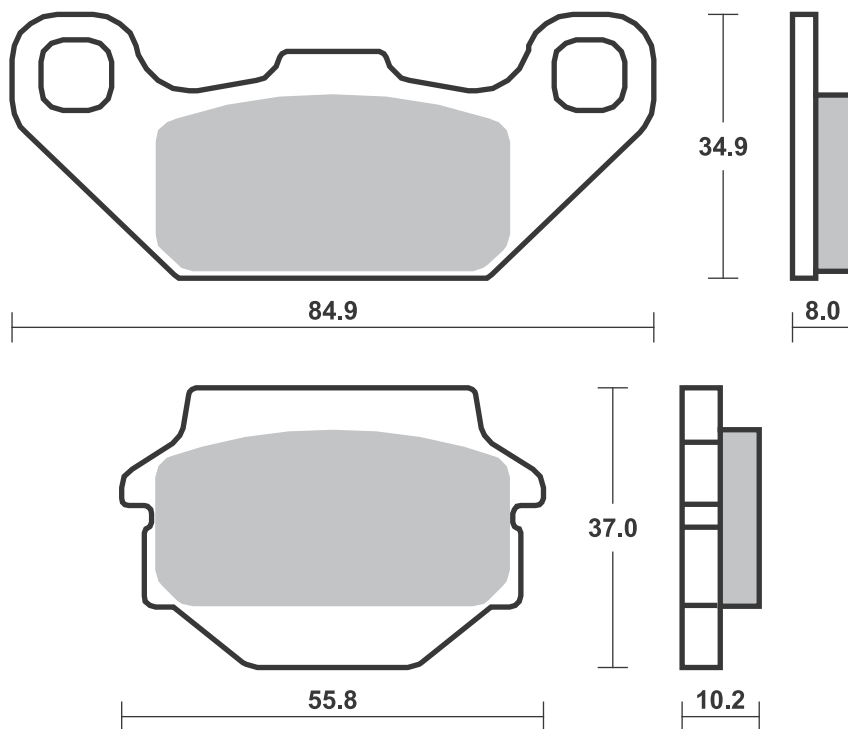



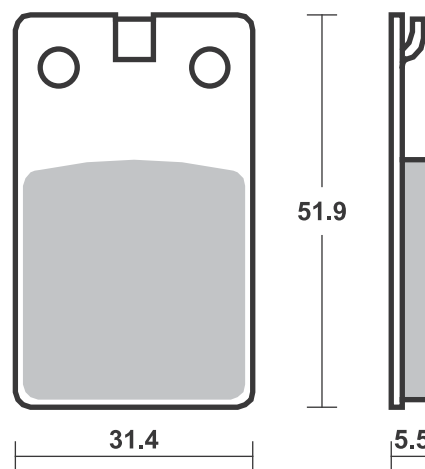
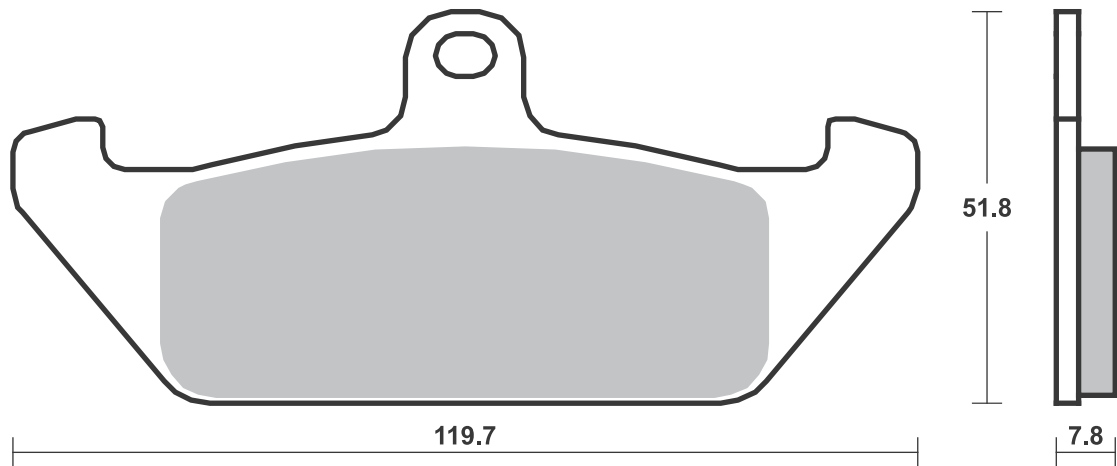
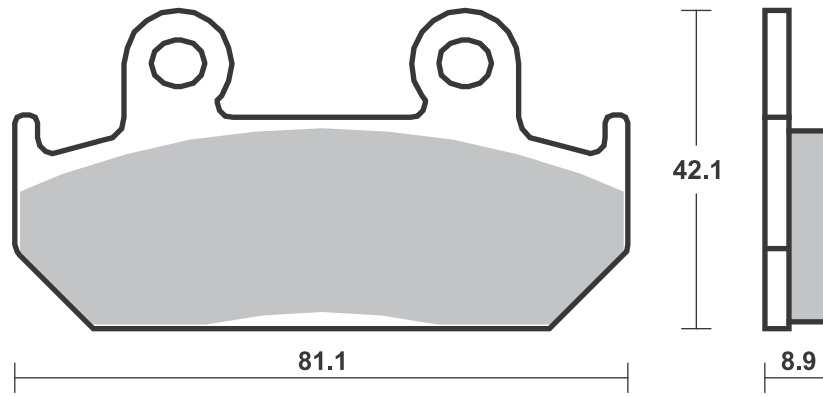



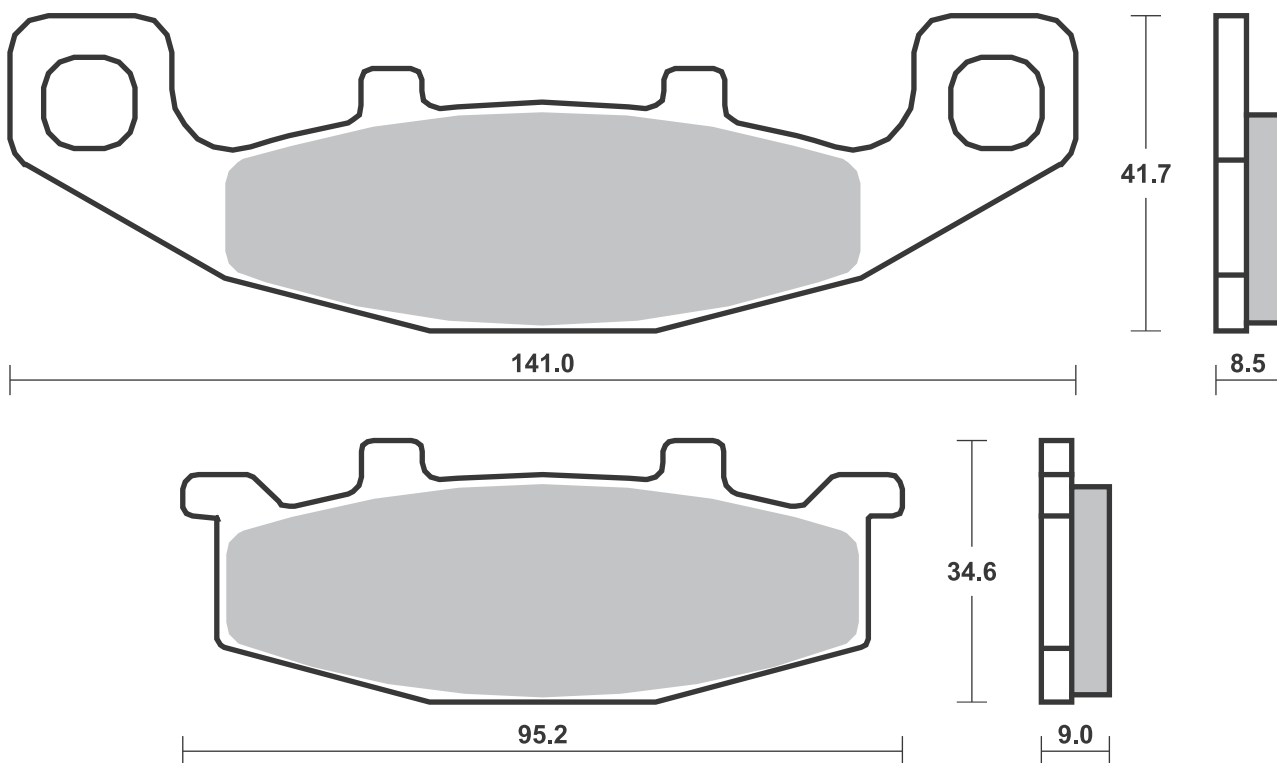
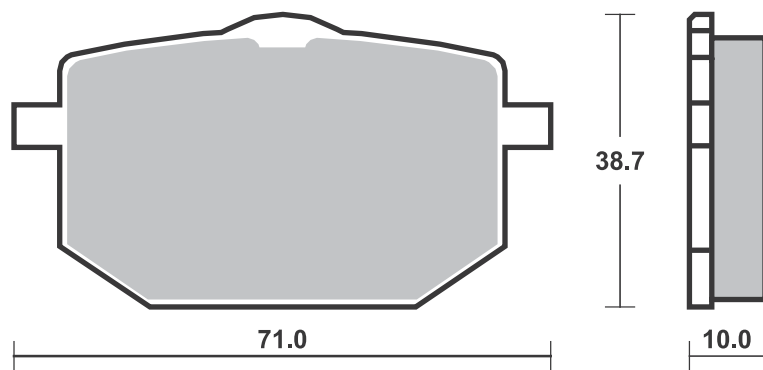





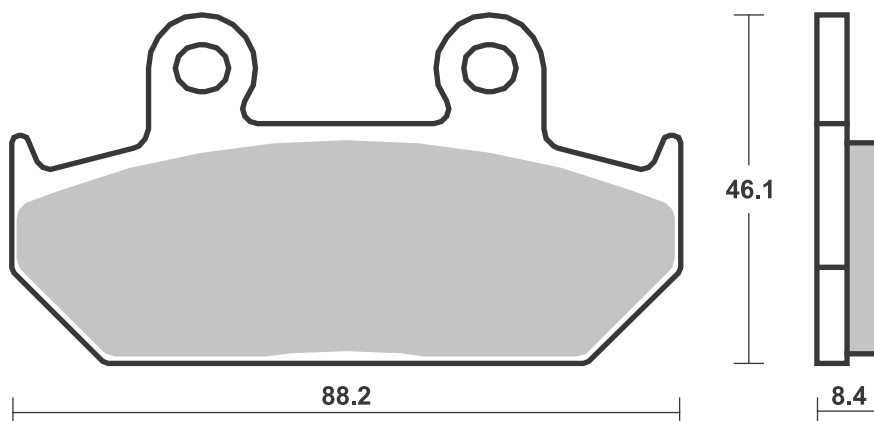
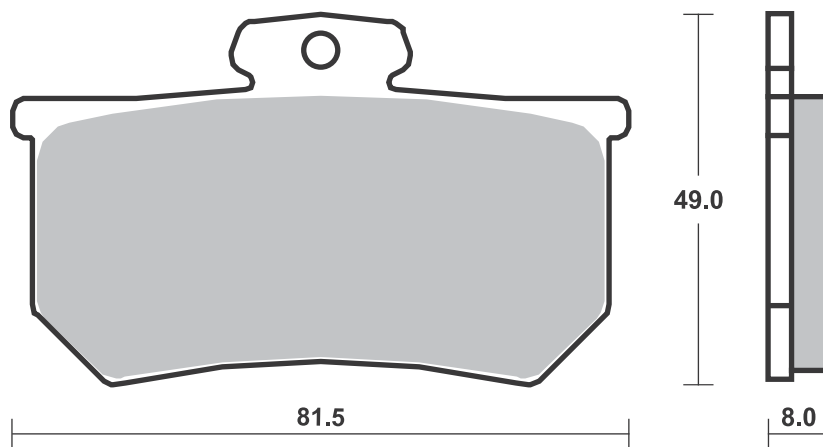
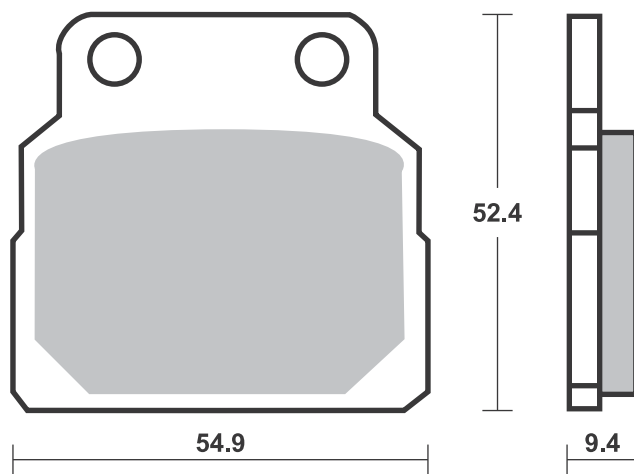



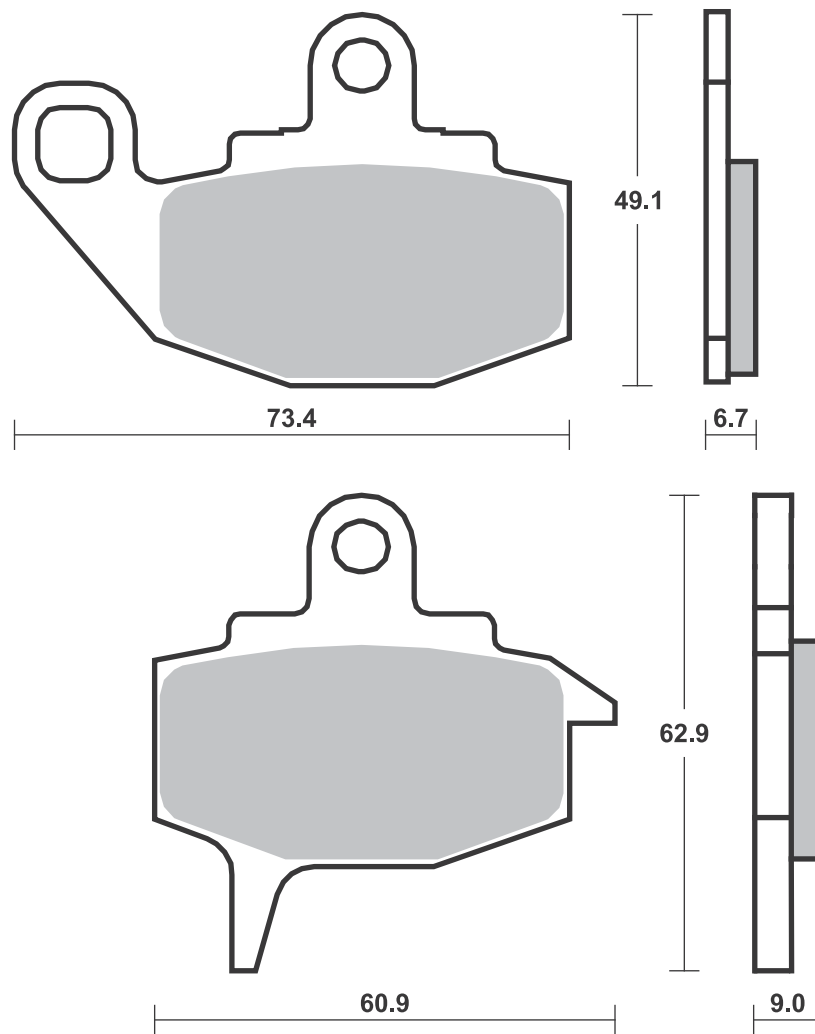
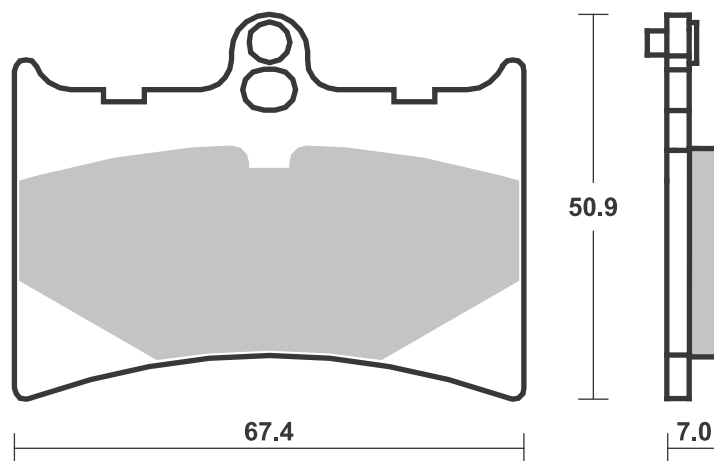



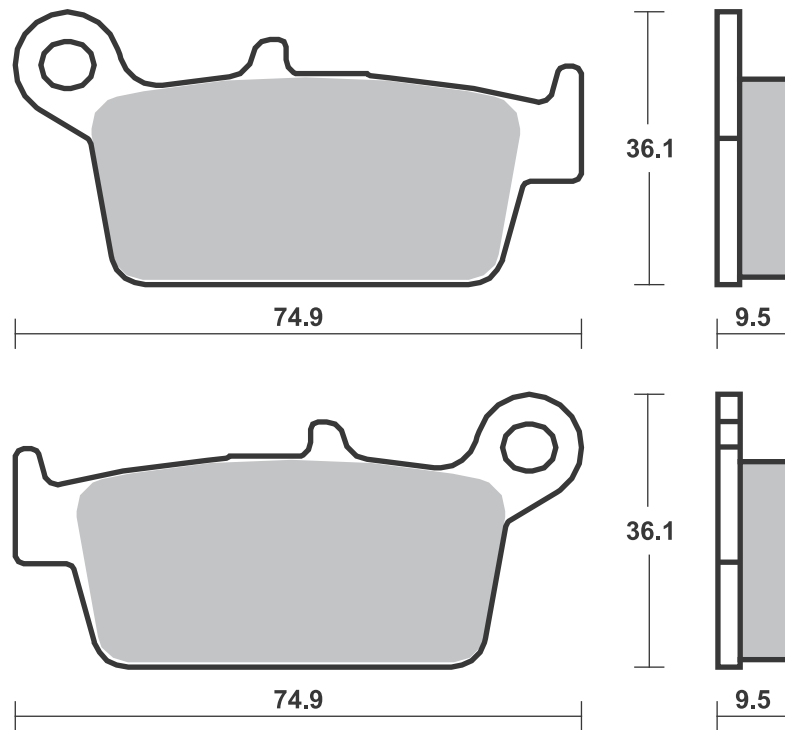
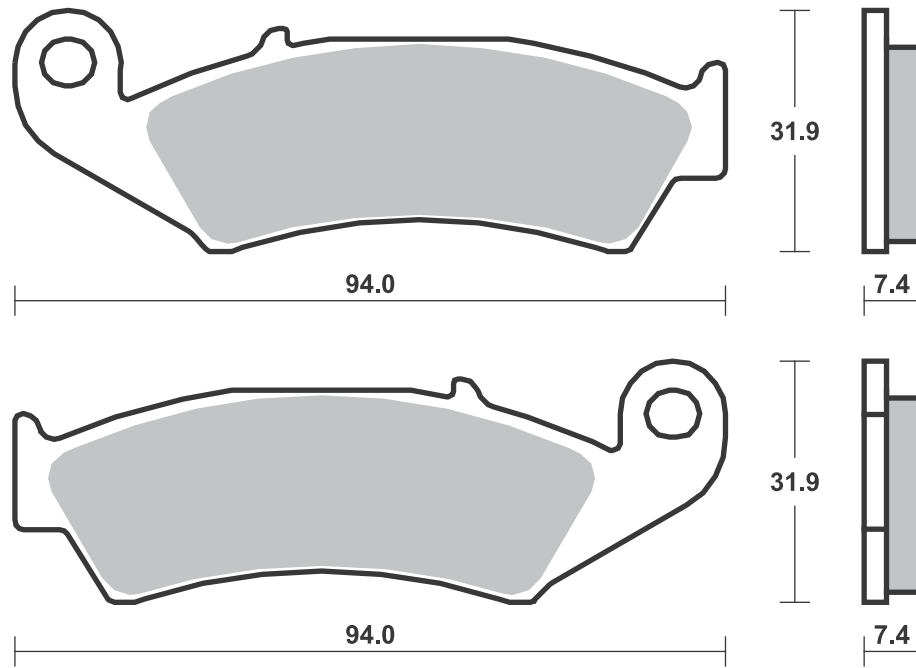





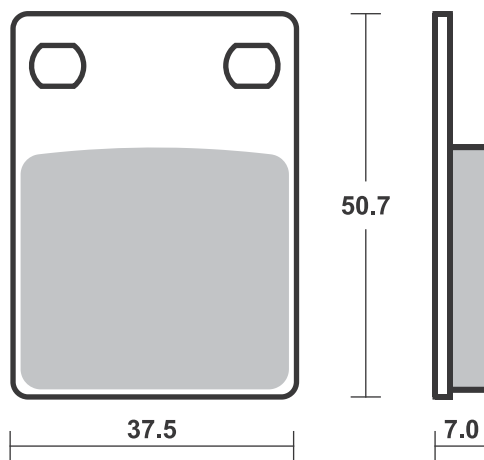
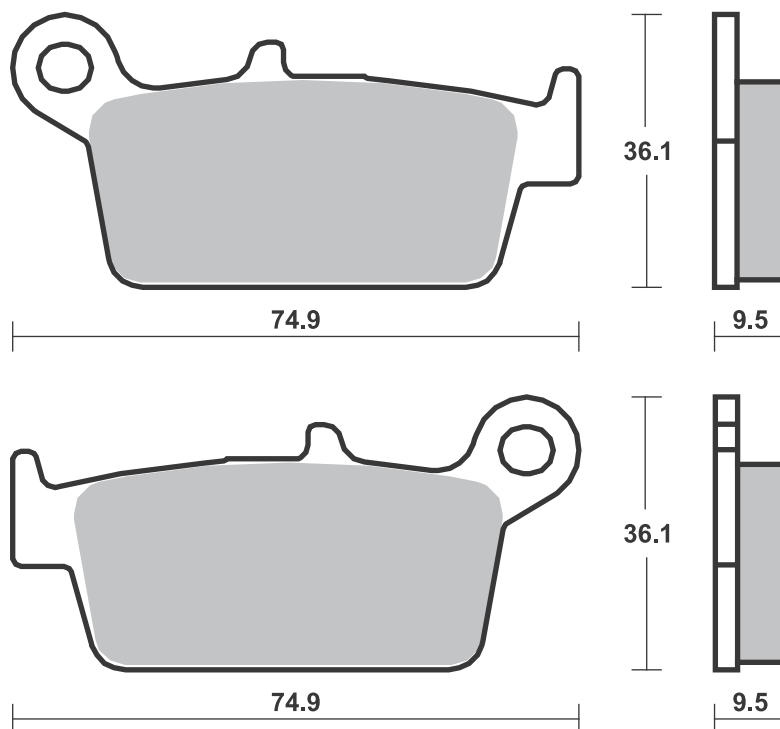



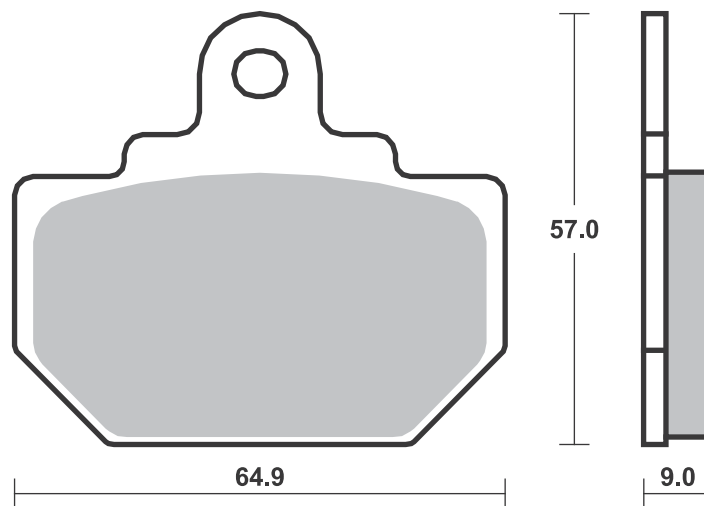
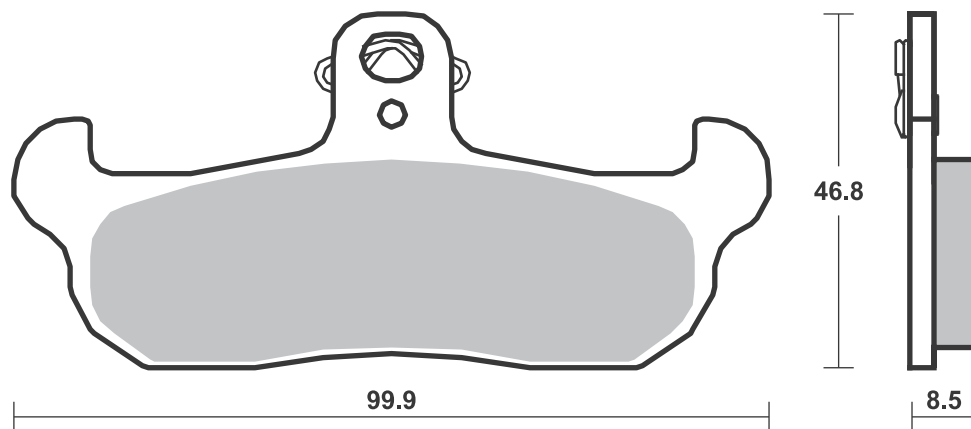
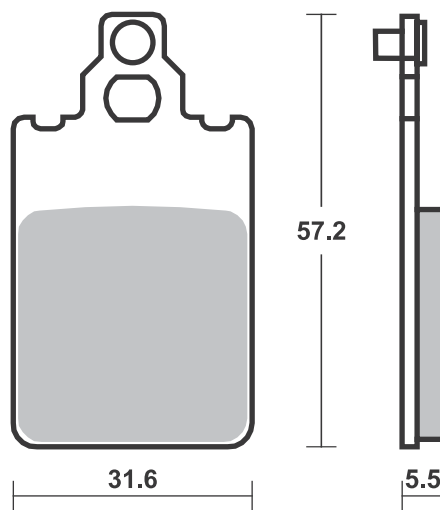



ATK			
all models	94	SI	SI

CAN-AM			
800 Commander			
Left/Rear	11-14		SI
800 Commander			
Right	11-14	SI	
1000 Commander			
Left/Rear	11-14		SI
1000 Commander			
MAX Right	14-18	SI	
1000 Commander			
Right	11-14	SI	
1000 Maverick			
Right	13-18	SI	

CF MOTO			
550 U-Force Right	15-16	SI	
550 Z-Force Right	15-16	SI	
800 Z-Force EX			
Right	15	SI	

DERBI			
DXR 200 Quad			
(Front drum)	04-05		SI
DXR 250 Quad			
(Front drum)	04-05		SI

HISUN			
HS 400 UTV Right	15-17	SI	
HS 500 UTV Right	15-17	SI	
HS 700 UTV Right	15-17	SI	
HS 700 UTV Right			
(2 cal.rear)	15-17	SI	SI
HS 800 UTV Right			
(2 cal.rear)	15-17	SI	SI

HONDA			
NSR 150	02		HF

HUSQVARNA			
all models			
CR,TC,TE,			
WR	92-94	SI	

HYOSUNG			
125 Aquila	00-04		HF

KAWASAKI			
KLX 125	10-14		HF
KLX 125 D-Tracker	10-14		HF
KX 125	89-93		RSI
KLX 140 , L	08-18		SI
KLX 150 D-Tracker	16-18		HF
KLX 150 L	14-15		HF
KDX 200	93		SI
KDX 250 SR	91-94		SI
KLX 250	14-16		HF
KLX 250	18-		HF
KLX 250 Camo	18-		HF
KLX 250 S	09-14		HF
KLX 250 SF	09-10		HF
KX 250	89-93		RSI
KLF 300 Bayou			
Left/Rear	89-05		SI
KLF 400 Bayou Left	93-99		SI
KX 500	89-93		RSI



KAWASAKI			
KLR 650	08-18		HS
KLR 650 Camo	08-18		HS
KVF 650 Brute Force			
4x4i Left	05-11		SI
KRF 750 Teryx 4x4 Left	08-13		SI
KVF 750 Brute Force			
4x4i Left	05-15		SI
800 Mule Pro FX			
Left	15-17		SI
KRF 800 Teryx			
BEF/CEF/DEF			
Left	14-17		SI
KRT 800 Teryx 4			
BEF/CEF/DEF			
Left	14-17		SI

SUZUKI			
RM 125	87		SI
RM 125	88-90		RSI
DR 250	90-95		HF
RM 250	87-95		RSI
RMX 250	89-95		RSI
LT-F 300 King Quad			
Left/Rear	02		SI
DR 350	90-99		HF
LT-R 450 Left/Rear	06-12		SI
LT-A 500 FY Quadmaster			
Left	00-08		SI
LT-F 500 F Right	98-07		SI
RM 500	87-89		RSI

TRIUMPH			
750 Trident			
Left/Rear	91-98		HS LS
800 America	03-06		LS
800 Bonneville	01-04		LS
800 Bonneville			
America	02-06		LS
800 Bonneville T100			
Centennial			
Edition	02-04		LS
800 Bonneville T100			
Paul Smith	06-08		LS
800 Speedmaster	03-04		LS
900 America	07-16		LS
900 Bonneville	09-11		LS
900 Bonneville			
Newchurch	15		LS
900 Bonneville SE	09-13		LS
900 Bonneville			
Spirit	15		LS
900 Bonneville			
Street Cup	17-18		LS
900 Bonneville T100	05-18		LS
900 Bonneville			
T100 Black	16-18		LS
900 Bonneville T214	15		LS
900 Daytona, Sprint			
Left/Rear	93		HS LS
900 Scrambler	06-16		LS
900 Speedmaster	05-15		LS
900 Street			
Scrambler	17-18		LS
900 Street Twin	16-18		LS
900 Thruxton	04-05		LS
900 Thruxton Ace	15		LS
900 Tiger Left/Rear	93-98		HS LS



TRIUMPH			
900 Trident			
Left/Rear	91-98		HS LS
900 Trophy			
Left/Rear	91-95		HS LS
T509 900 Speed Triple	97-01		LS
T595 950 Daytona	96-98		LS
955 Daytona			
Centennial	02-04		LS
955 Daytona			
to VIN 132512	99-06		LS
955 Speed Triple	99-06		LS
955 Sprint RS	00-05		LS
955 Sprint ST	99-04		LS
1000 Trophy			
Left/Rear	91-95		HS LS
1050 Speed 94	15-16		LS
1050 Speed 94R	15-16		LS
1050 Speed Triple	16-17		LS
1050 Speed Triple	05-15		LS
1050 Speed Triple R	12-18		LS
1050 Speed Triple S	16-18		LS
1050 Sprint GT ABS	10-15		LS
1050 Sprint GT SE			
ABS	10-15		LS
1050 Sprint ST	05-11		LS
1050 Tiger Sport	15-18		LS
1200 Bonneville			
T120	16-18		LS
1200 Bonneville			
T120 Black	16-18		LS
1200 Thruxton	16-18		LS
1200 Thruxton R	16-18		LS
1200 Tiger Explorer	12-17		LS
1200 Tiger XCA	18-		LS
1200 Tiger XCX	18-		LS
1200 Tiger XR	18-		LS
1200 Tiger XRT	18-		LS
1200 Tiger XR	18-		LS
1200 Tiger XR Low	18-		LS
1200 Trophy			
Left/Rear	91-95		HS LS
1200 Trophy SE	13-18		LS

YAMAHA			
WR 125	91-97		SI
YZ 125	89-97		RSI
WR 200	91-92		SI
TT-R 230	05		SI
TT 250	93-03		SI
WR 250	90-97		SI
YZ 250	89		RSI
YZ 250 A	90		RSI
YZ 250 B1-J1	91-97		RSI
YZ 250 WRA,WRB	90-91		RSI
TT 350	95-00		SI
YFZ 450 S Right	04-09		SI
YXR 450 Rhino			
Left/Rear	06-09		SI
WR 500 B	91		SI
WR 500 ZD,ZE	92-93		SI
660 Rhino			
Left/Rear	05-08		SI
YFM 700 R Raptor			
Left/Rear	06-08		SI
YFM 700 Raptor	09-14		SI
YXR 700 Rhino Right	08-14		SI SI

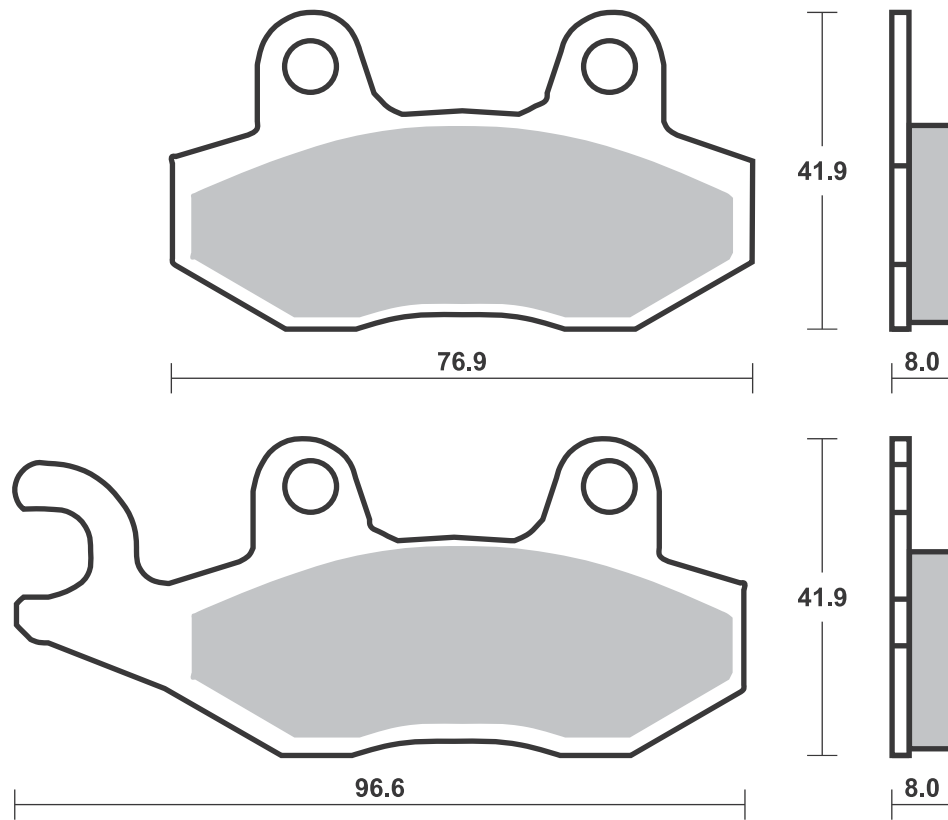



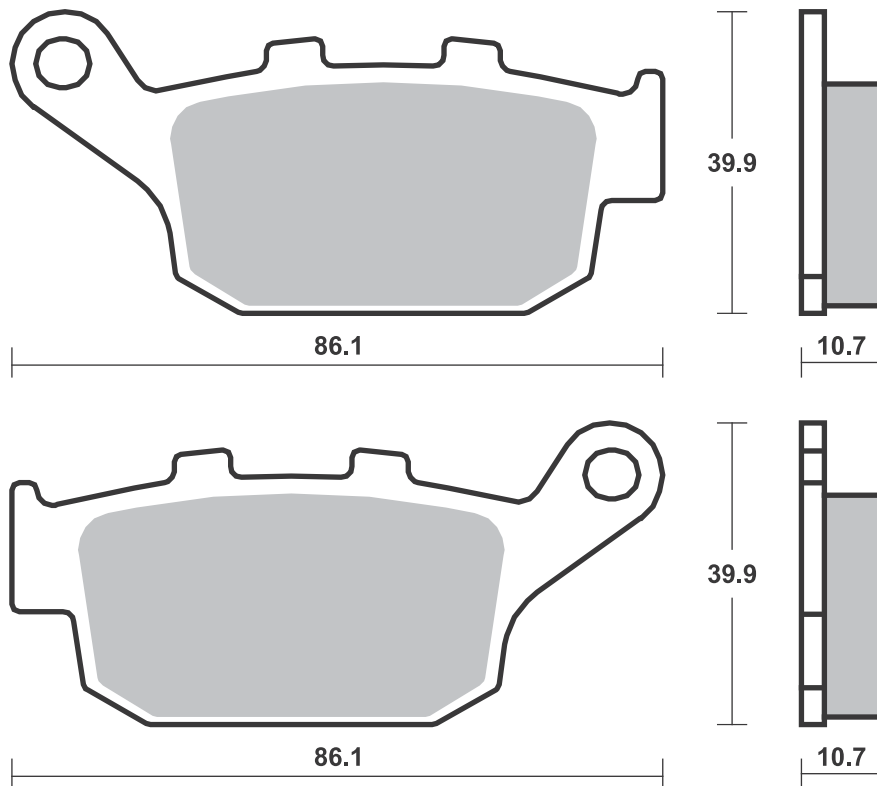
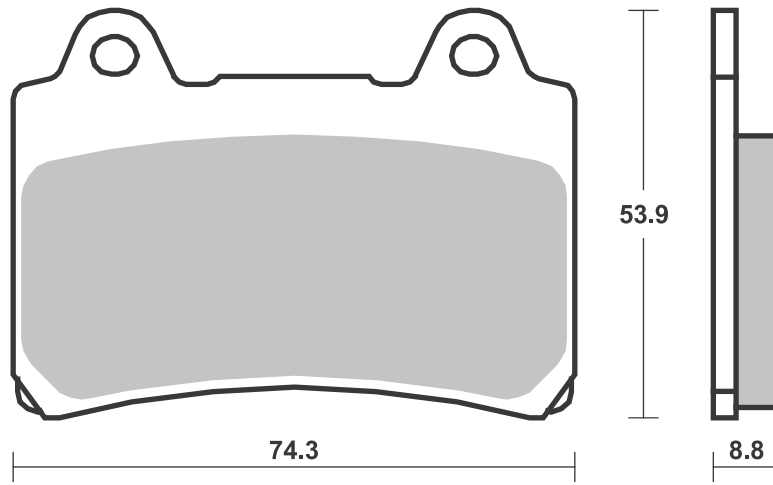





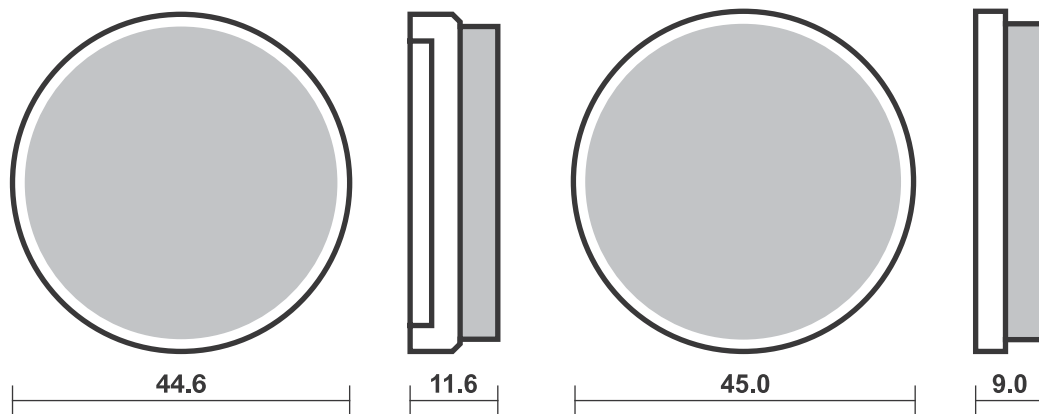
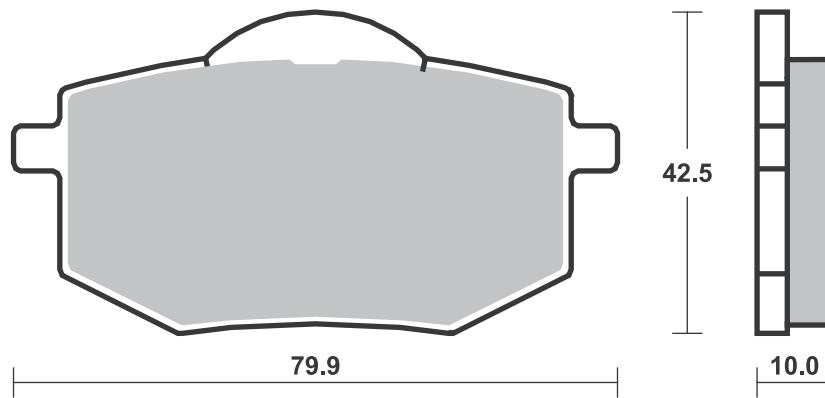
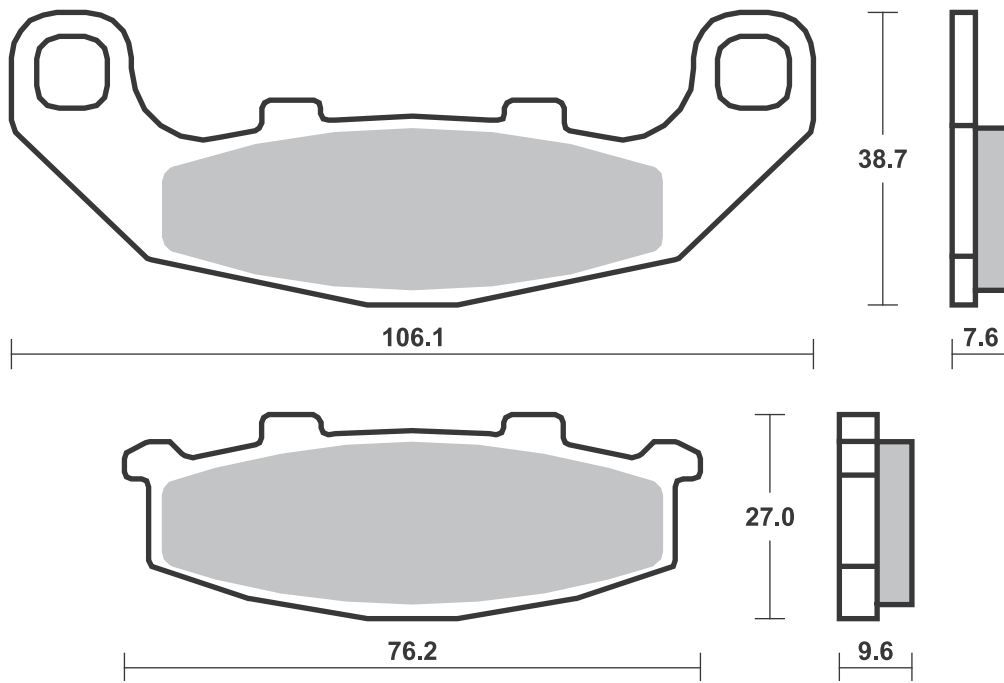



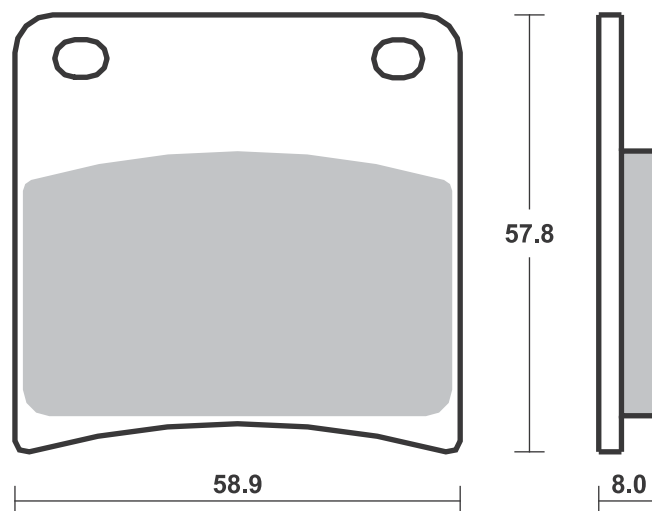
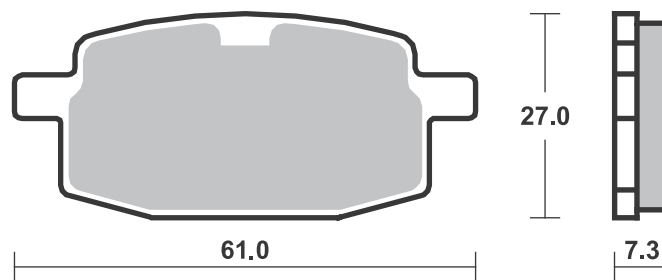
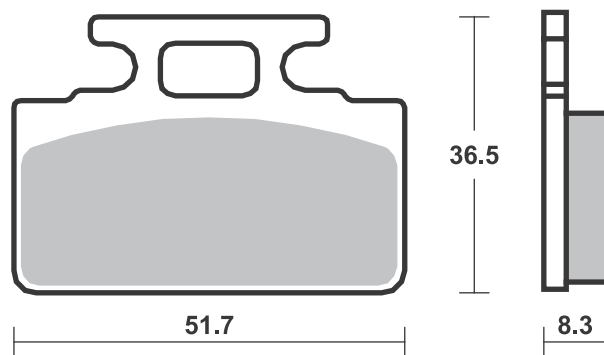



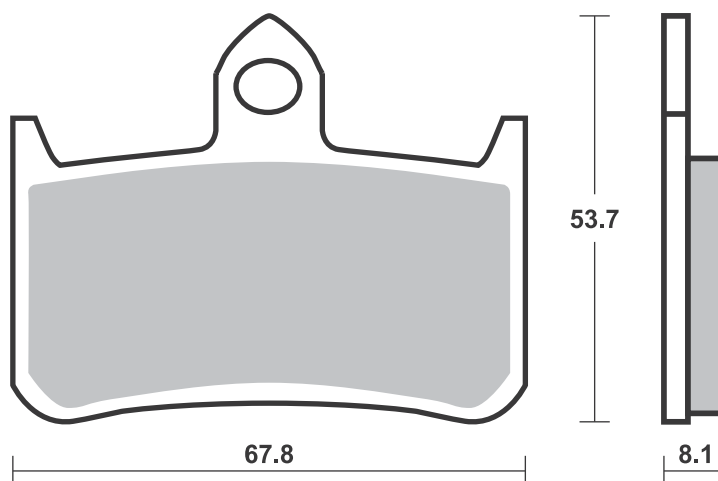
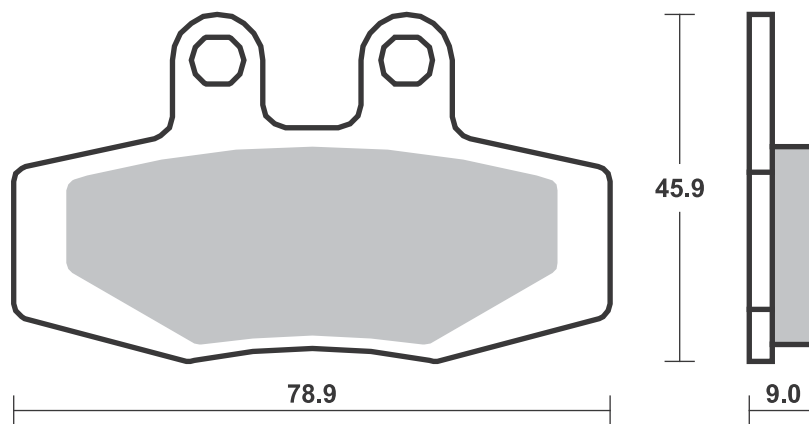





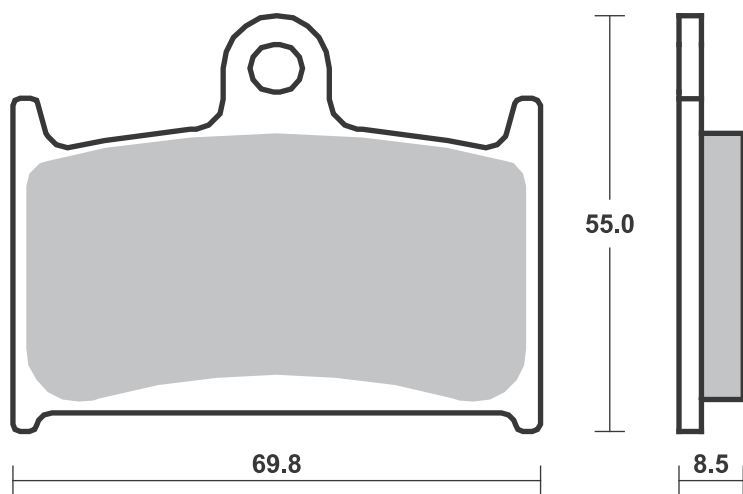
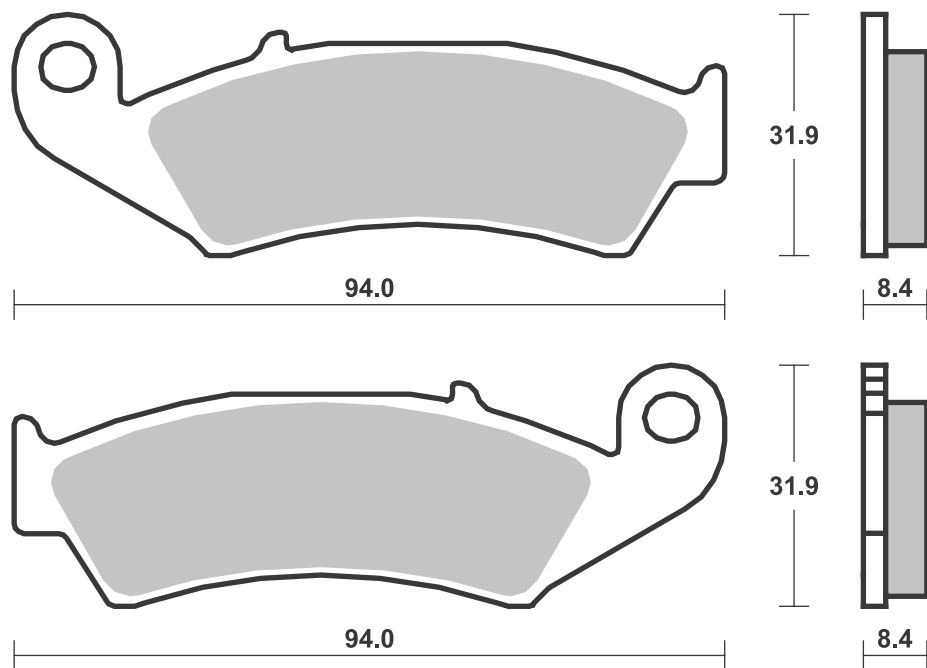



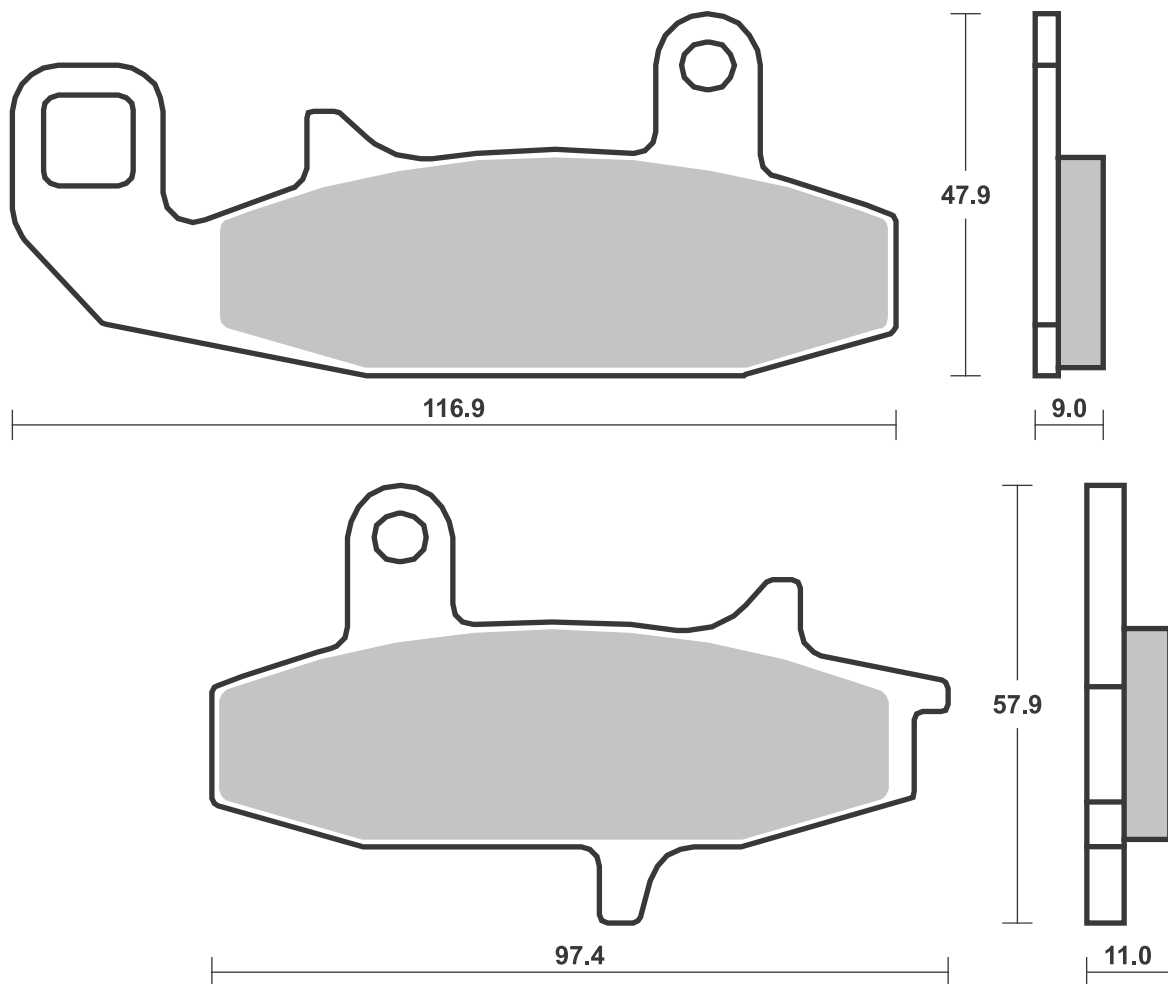
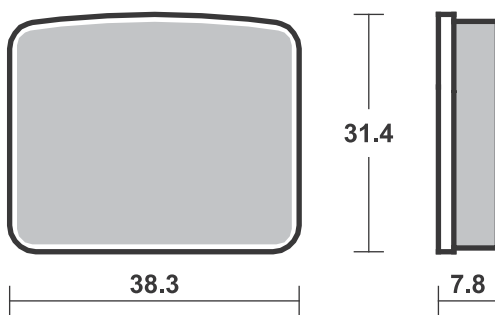

## SBS 627 Recommended compound



<b>BUELL</b>			
500 Blast	01-09	<b>HF</b>	

<b>CAGIVA</b>			
900 Gran Canyon	99-04	<b>HS</b>	
1000 Navigator, T	00-05	<b>HS</b>	

**HONDA**

RS 125 R	91-94	<b>HF</b>	
CBR 250 R (Nissin cal)	11-13	<b>HS</b>	
CB-1 400 (CB 400 F)	89-90	<b>HS</b>	
CB 599	04	<b>HS</b>	
CB 600 Hornet	07-12	<b>HS</b>	
CBR 600 F	11-13	<b>HS</b>	
CBR 600 F3	95-98	<b>HS</b>	
VT 600 C, Shadow	94-00	<b>HS</b>	
VT 600 CD Shadow			

VLX	94-00	<b>HS</b>	
-----	-------	-----------	--

FMX 650	05-08	<b>HS</b>	
---------	-------	-----------	--

NT 650 Hawk GT	88-91	<b>HS</b>	
----------------	-------	-----------	--

NC 700 S	12-13	<b>HS</b>	
----------	-------	-----------	--

NC 700 X	12-13	<b>HS</b>	
----------	-------	-----------	--

VFR 700 F Interceptor	88-89	<b>HS</b>	
-----------------------	-------	-----------	--

CB 750 N, F, Seven			
--------------------	--	--	--

Fifty	92-95	<b>HS</b>	
-------	-------	-----------	--

CB 750 Nighthawk	91-02	<b>HS</b>	
------------------	-------	-----------	--

VFR 750 F	88-98	<b>HS</b>	
-----------	-------	-----------	--

PC 800 Pacific Coast	89-97	<b>HS</b>	
----------------------	-------	-----------	--

CBR 1000 F	89-92	<b>HS</b>	
------------	-------	-----------	--

ST 1100 ABS-TCS	92-95	<b>HS</b>	
-----------------	-------	-----------	--

VT 1100 C Shadow	94-96	<b>HS</b>	
------------------	-------	-----------	--

VT 1100 C2 Shadow			
-------------------	--	--	--

A.C.E.	95-04	<b>HS</b>	
--------	-------	-----------	--

VT 1100 C2 Shadow			
-------------------	--	--	--

Sabre	00-05	<b>HS</b>	
-------	-------	-----------	--

VT 1100 C3 Shadow			
-------------------	--	--	--

Aero	98-04	<b>HS</b>	
------	-------	-----------	--

VT 1100 T Shadow	98-04	<b>HS</b>	
------------------	-------	-----------	--

VT 1300 CX A Fury	10-18	<b>HS</b>	
-------------------	-------	-----------	--

VT 1300 Interstate	11-15	<b>HS</b>	
--------------------	-------	-----------	--

VT 1300 Sabre	11-13	<b>HS</b>	
---------------	-------	-----------	--

VT 1300 Stateline	11-16	<b>HS</b>	
-------------------	-------	-----------	--

VTX 1300 C	04-09	<b>HS</b>	
------------	-------	-----------	--

VTX 1300 S	03-07	<b>HS</b>	
------------	-------	-----------	--

GL 1500 Valkyrie	96-03	<b>HS</b>	
------------------	-------	-----------	--

**HYOSUNG**

125 V2	99-11	<b>HF</b>	
--------	-------	-----------	--

250 Aquila	00-09	<b>HF</b>	
------------	-------	-----------	--

**KAWASAKI**

KLE 300 Versys-X	17-18	<b>HS</b>	
------------------	-------	-----------	--

KLE 650 Versys	15-18	<b>HS</b>	
----------------	-------	-----------	--

KLE 650 Versys LT	15-16	<b>HS</b>	
-------------------	-------	-----------	--

Z 650 ABS	17-18	<b>HS</b>	
-----------	-------	-----------	--

Z 750 , ABS	07-12	<b>HS</b>	
-------------	-------	-----------	--

Z 800 e	13-16	<b>HS</b>	
---------	-------	-----------	--

**KYMCO**

250 Venox	01-14	<b>HF</b>	<b>HF</b>
-----------	-------	-----------	-----------

**SUZUKI**

DL 250 V-Strom	17-18	<b>HF</b>	
----------------	-------	-----------	--

GSX-R 250	17-18	<b>HF</b>	
-----------	-------	-----------	--

GW 250 Inazuma	12-18	<b>HS</b>	
----------------	-------	-----------	--

GW 250 Inazuma F	15-18	<b>HS</b>	
------------------	-------	-----------	--

GSF 600 Bandit	95-99	<b>HS</b>	
----------------	-------	-----------	--

RF 600 R	93-96	<b>HS</b>	
----------	-------	-----------	--



<b>SUZUKI</b>			
C 1500 T Intruder	13-18	<b>HS</b>	

C90 1500 Boulevard			
--------------------	--	--	--

B.O.S.S.	13-18	<b>HS</b>	
----------	-------	-----------	--

**SWM**

440 Gran Milano	15-17	<b>HS</b>	
-----------------	-------	-----------	--

440 Gran Turismo	15-18	<b>HS</b>	
------------------	-------	-----------	--

440 Silver Vase	15-18	<b>HS</b>	
-----------------	-------	-----------	--

440 Six Days	18-	<b>HS</b>	
--------------	-----	-----------	--

**TRIUMPH**

660 Street Triple			
-------------------	--	--	--

S A2	17-18	<b>HS</b>	
------	-------	-----------	--

675 Street Triple	08-17	<b>HS</b>	
-------------------	-------	-----------	--

765 Street Triple			
-------------------	--	--	--

S	17-18	<b>HS</b>	
---	-------	-----------	--

800 America	03-06	<b>HS</b>	
-------------	-------	-----------	--

800 Bonneville	01-04	<b>HS</b>	
----------------	-------	-----------	--

800 Bonneville			
----------------	--	--	--

America	02-06	<b>HS</b>	
---------	-------	-----------	--

800 Bonneville			
----------------	--	--	--

T100			
------	--	--	--

Centennial			
------------	--	--	--

Edition	02-04	<b>HS</b>	
---------	-------	-----------	--

800 Bonneville			
----------------	--	--	--

T100			
------	--	--	--

Paul Smith	06-08	<b>HS</b>	
------------	-------	-----------	--

800 Speedmaster	03-04	<b>HS</b>	
-----------------	-------	-----------	--

800 Tiger	11-14	<b>HS</b>	
-----------	-------	-----------	--

800 Tiger XC	11-17	<b>HS</b>	
--------------	-------	-----------	--

800 Tiger XC			
--------------	--	--	--

ABS	12-14	<b>HS</b>	
-----	-------	-----------	--

800 Tiger XCA	15-17	<b>HS</b>	
---------------	-------	-----------	--

800 Tiger XCR	15-17	<b>HS</b>	
---------------	-------	-----------	--

800 Tiger XR	15-17	<b>HS</b>	
--------------	-------	-----------	--

800 Tiger XR	18-	<b>HS</b>	
--------------	-----	-----------	--

800 Tiger XRT	15-17	<b>HS</b>	
---------------	-------	-----------	--

800 Tiger XRX	15-17	<b>HS</b>	
---------------	-------	-----------	--

900 Adventurer	96-02	<b>HS</b>	
----------------	-------	-----------	--

900 America	07-16	<b>HS</b>	
-------------	-------	-----------	--

900 Bonneville	05-11	<b>HS</b>	
----------------	-------	-----------	--

900 Bonneville			
----------------	--	--	--

Newchurch	15	<b>HS</b>	
-----------	----	-----------	--

900 Bonneville			
----------------	--	--	--

SE	09-13	<b>HS</b>	
----	-------	-----------	--

900 Bonneville			
----------------	--	--	--

Spirit	15	<b>HS</b>	
--------	----	-----------	--

900 Bonneville			
----------------	--	--	--

Street Cup	17-18	<b>HS</b>	
------------	-------	-----------	--

900 Bonneville			
----------------	--	--	--

T100	05-18	<b>HS</b>	
------	-------	-----------	--

900 Bonneville			
----------------	--	--	--

T100 Black	16-18	<b>HS</b>	
------------	-------	-----------	--

900 Bonneville			
----------------	--	--	--

T214	15	<b>HS</b>	
------	----	-----------	--

900 Legend TT	99-01	<b>HS</b>	
---------------	-------	-----------	--

900 Scrambler	06-16	<b>HS</b>	
---------------	-------	-----------	--

900 Speedmaster	05-15	<b>HS</b>	
-----------------	-------	-----------	--

900 Street			
------------	--	--	--

Scrambler	17-18	<b>HS</b>	
-----------	-------	-----------	--

900 Street Twin	16-18	<b>HS</b>	
-----------------	-------	-----------	--

900 Thruxton	04-05	<b>HS</b>	
--------------	-------	-----------	--

900 Thruxton Ace	15	<b>HS</b>	
------------------	----	-----------	--

900 Thunderbird	96-05	<b>HS</b>	
-----------------	-------	-----------	--

900 Thunderbird			
-----------------	--	--	--

Sport	03-04	<b>HS</b>	
-------	-------	-----------	--

900 Tiger	99-00	<b>HS</b>	
-----------	-------	-----------	--



<b>TRIUMPH</b>			
955 Tiger	01-04	<b>HS</b>	<b>HF</b>

955 Tiger	04-06	<b>HS</b>	
-----------	-------	-----------	--

1200 Bonneville			
-----------------	--	--	--

Bobber	17	<b>HS</b>	
--------	----	-----------	--

1200 Bonneville			
-----------------	--	--	--

T120	16-18	<b>HS</b>	
------	-------	-----------	--

1200 Bonneville			
-----------------	--	--	--

T120 Black	16-18	<b>HS</b>	
------------	-------	-----------	--

1200 Thruxton	16-18	<b>HS</b>	
---------------	-------	-----------	--

**YAMAHA**

WR 125 R, XY	09-16	<b>HF</b>	
--------------	-------	-----------	--

WR 250 X	08-16	<b>HS</b>	
----------	-------	-----------	--

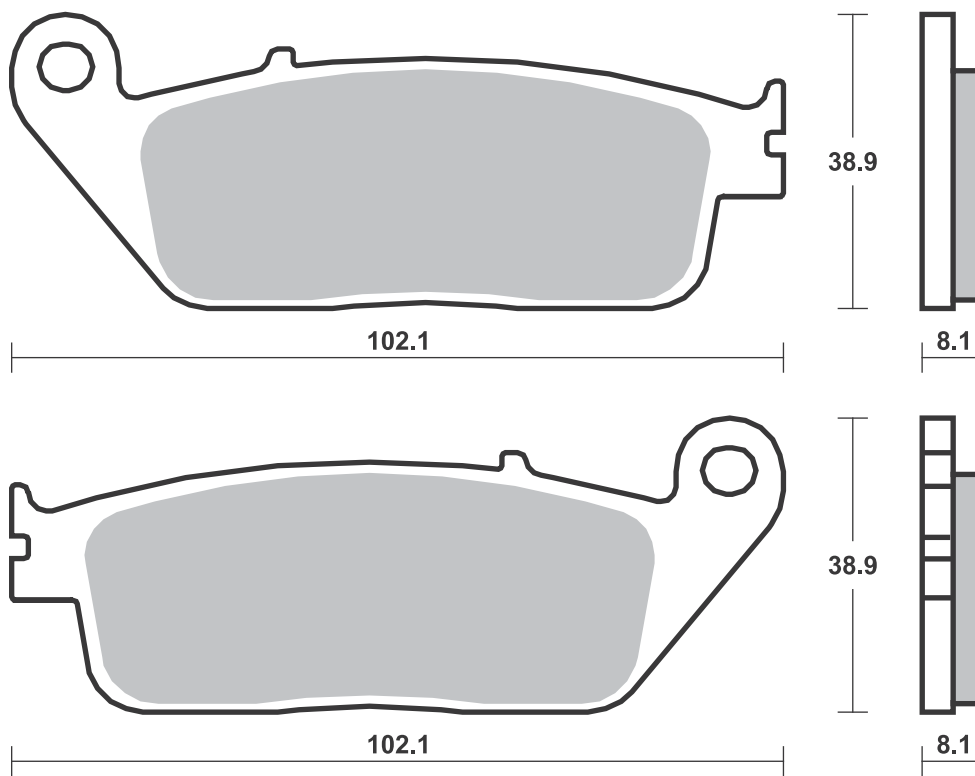

**SBS 630 Recommended compound**

<b>HONDA</b>			
DN-01	680	08-11	<b>LS</b>
VF	750 C,		
	CD Magna	94-98	<b>HS</b>
VFR	750 F	88-98	<b>LS</b>
CBR	1000 F	89-92	<b>LS</b>
CTX	1300	14-18	<b>LS</b>
GL	1500 Valkyrie	96-03	<b>LS</b>

<b>INDIAN</b>			
	1800 Chief	15-18	<b>H.LS</b>
	1800 Chief Classic	14-18	<b>H.LS</b>
	1800 Chief Dark Horse	15-18	<b>H.LS</b>
	1800 Chief Vintage	14-18	<b>H.LS</b>
	1800 Chieftain	14-18	<b>H.LS</b>
	1800 Chieftain Classic	15-18	<b>H.LS</b>
	1800 Chieftain Dark Horse	15-18	<b>H.LS</b>
	1800 Chieftain Limited	15-18	<b>H.LS</b>
	1800 Dark Horse	16-18	<b>H.LS</b>
	1800 Roadmaster	15-18	<b>H.LS</b>
	1800 Roadmaster Classic	15-18	<b>H.LS</b>
	1800 Roadmaster Elite	15-18	<b>H.LS</b>
	1800 Springfield	16-18	<b>H.LS</b>
	1800 Springfield Dark Horse	15-18	<b>H.LS</b>



<b>TRIUMPH</b>			
	900 Adventurer	96-02	<b>LS</b>
	900 Legend TT	99-01	<b>LS</b>
	900 Thunderbird	96-05	<b>LS</b>
	900 Thunderbird Sport	03-04	<b>LS</b>
	900 Tiger	99-00	<b>LS</b>

<b>VICTORY</b>			
	1634 Hammer	08	<b>H.LS</b>
	1634 Kingpin		
	all models	08-12	<b>H.LS</b>
	1634 Vegas	08-17	<b>H.LS</b>
	1634 Vegas 8-Ball	08-17	<b>H.LS</b>
	1634 Vegas Jackpot	08	<b>H.LS</b>
	1731 Boardwalk	13-15	<b>H.LS</b>
	1731 Cross Country	10-17	<b>H.LS</b>
	1731 Cross Country 8-Ball	14-16	<b>H.LS</b>
	1731 Cross Country Tour	12-17	<b>H.LS</b>
	1731 Cross Roads	10-12	<b>H.LS</b>
	1731 Cross Roads 8-Ball	14	<b>H.LS</b>
	1731 Cross Roads Classic	14	<b>H.LS</b>
	1731 Gunner	15-17	<b>H.LS</b>
	1731 Hammer	09-11	<b>H.LS</b>



<b>VICTORY</b>			
	1731 Hammer 8-Ball	10-16	<b>H.LS</b>
	1731 Hammer S	09-17	<b>H.LS</b>
	1731 Hard-Ball	12-13	<b>H.LS</b>
	1731 High-Ball	12-17	<b>H.LS</b>
	1731 Jackpot	10-16	<b>H.LS</b>
	1731 Judge	13-17	<b>H.LS</b>
	1731 Kingpin	10-12	<b>H.LS</b>
	1731 Kingpin 8-Ball	10-11	<b>H.LS</b>
	1731 Magnum	15-17	<b>H.LS</b>
	1731 Magnum X-1	15-17	<b>H.LS</b>
	1731 Vegas	10-17	<b>H.LS</b>
	1731 Vegas 8-Ball	10-17	<b>H.LS</b>
	1731 Vegas Jackpot	09	<b>H.LS</b>
	1731 Vision		
	all models	08-17	<b>H.LS</b>

**SBS 631 Recommended compound**

<b>BERINGER</b>			
	4 Piston Caliper		

<b>HUSABERG</b>			
FS	400 e, c	01-03	<b>RSI</b>
FS	450 e, c	03-05	<b>RSI</b>
FS	650 e, c	01-05	<b>RSI</b>

<b>KAWASAKI</b>			
	600 R, Ninja	89-96	<b>HF</b>
ZX	600 Ninja	90-93	<b>HS</b>
ZX-6R	600 (Ninja ZX6)	93-97	<b>HS</b>
ZX-6R	600 (Ninja ZX6R)	95-97	<b>HS</b>
ZX-6R	600 (ZX6)	90-93	<b>HS</b>
ZX-7R	750 Ninja	89-95	<b>HS</b>
ZX-9R	900 Ninja	94-95	<b>HS</b>
KLE	1000 Versys	12-18	<b>SP</b>
KLE	1000 Versys ABS	15-16	<b>SP</b>
KLE	1000 Versys LT	15-16	<b>SP</b>
ZR	1100 Zephyr	92-95	<b>HS</b>
ZX	1100	93-97	<b>HS</b>
ZZR	1100	90-01	<b>HS</b>
ZZR	1200	02-04	<b>HS</b>
VN	1700 Vulcan		
	Voyager	09-16	<b>HS</b>
VN	2000 Vulcan	04-10	<b>HS</b>

<b>MOTO-MASTER</b>			
	Supermoto Racing Caliper		



<b>SUZUKI</b>			
GSR	600	06-10	<b>HS</b>
GSX-R	600	97-03	<b>HS</b>
GSF	650 Bandit	07-11	<b>HS</b>
GSF	650 Bandit ABS	07-12	<b>HS</b>
GSF	650 S Bandit	07-11	<b>HS</b>
	650 S Bandit ABS	07-13	<b>HS</b>
GSX	650 F	08-18	<b>HS</b>
GSX-R	750 Y	00-03	<b>HS</b>
SV	1000 , S	03-07	<b>HS</b>
TL	1000 S V-Twin	97-01	<b>HS</b>
GSF	1200 Bandit	06	<b>HS</b>
GSF	1200 S Bandit	06	<b>HS</b>
GSF	1250 A Bandit	07-18	<b>HS</b>
GSF	1250 Bandit	06-18	<b>HS</b>
GSF	1250 F Bandit	12-18	<b>HS</b>
GSF	1250 S Bandit	06-18	<b>HS</b>
GSF	1250 SA Bandit	07-18	<b>HS</b>
GSX	1250 FA Bandit	16-18	<b>HS</b>
GSX	1250 FA Traveller	15-16	<b>HS</b>

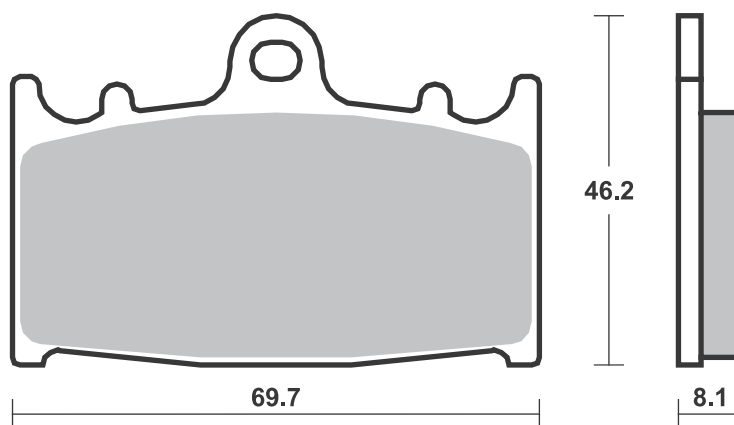
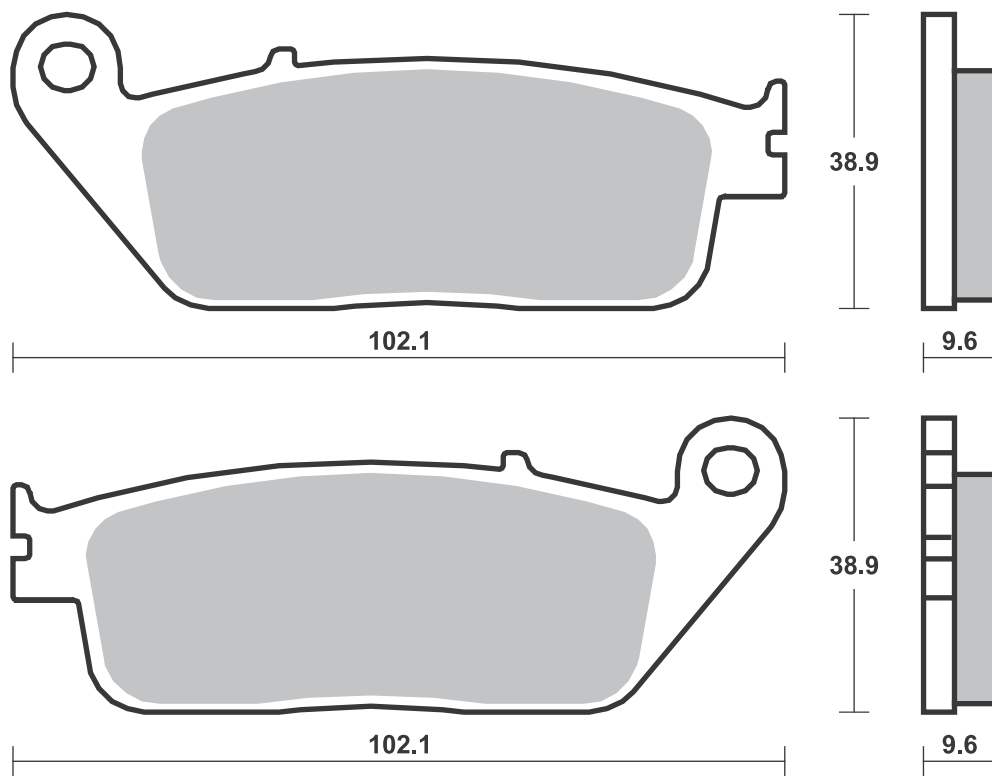





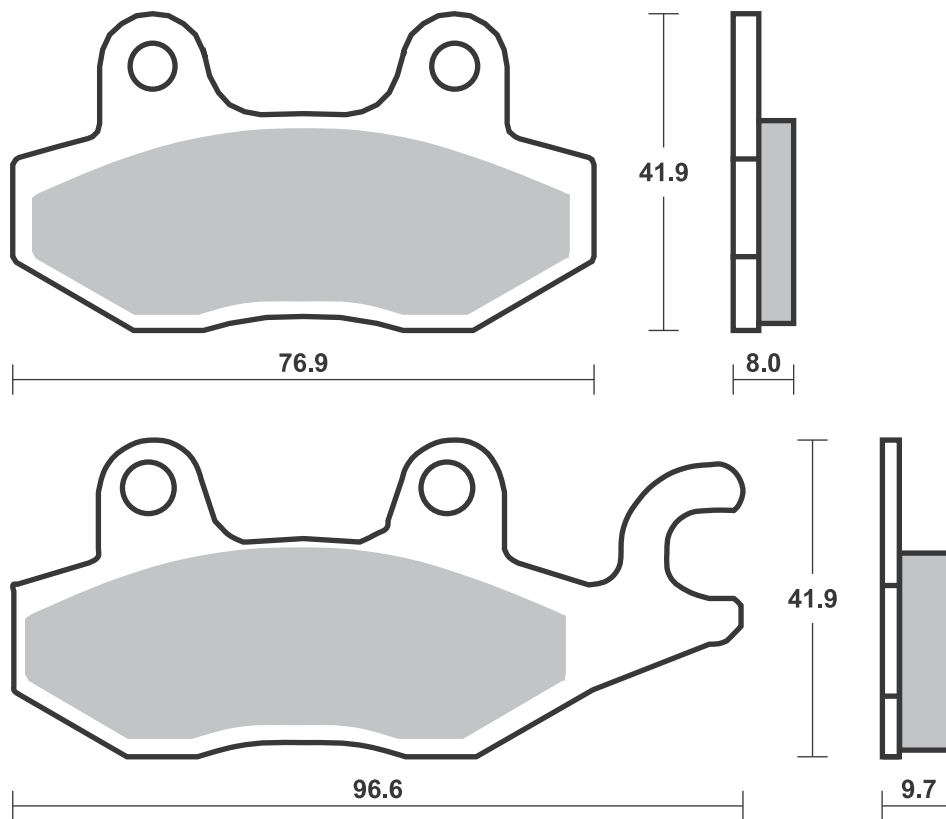
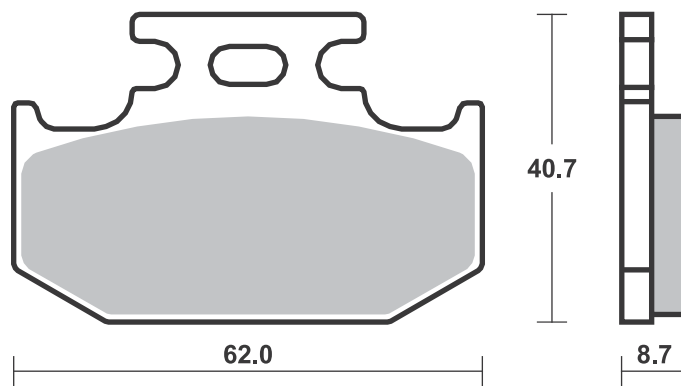



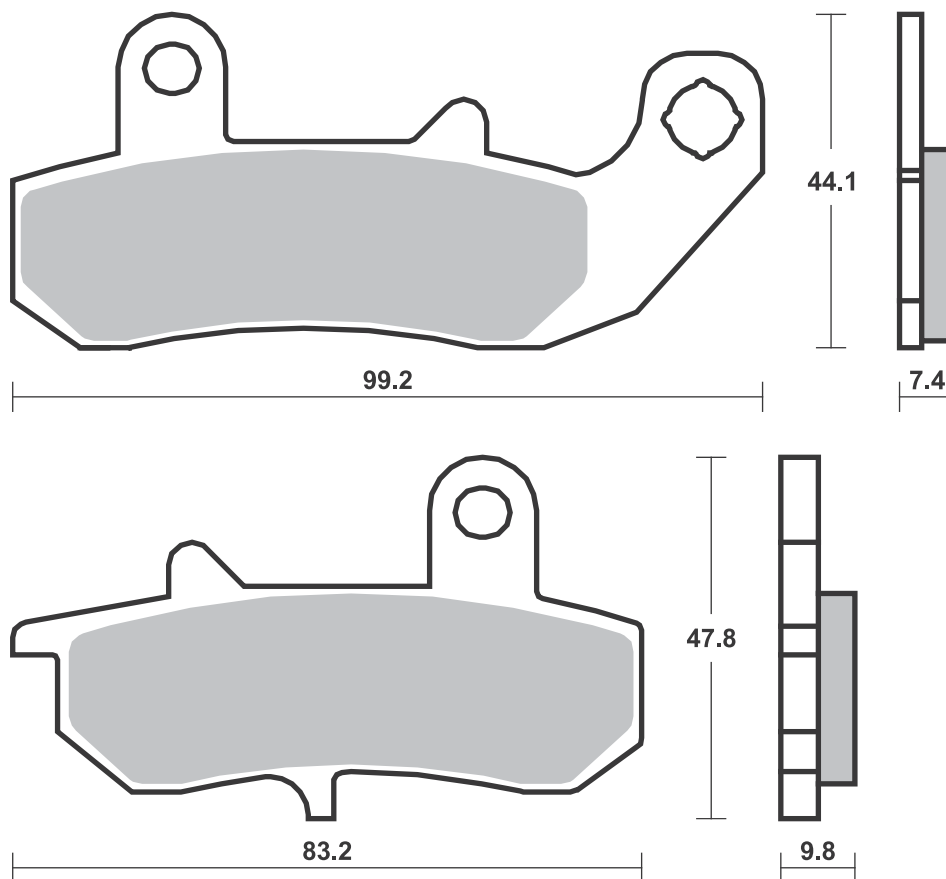
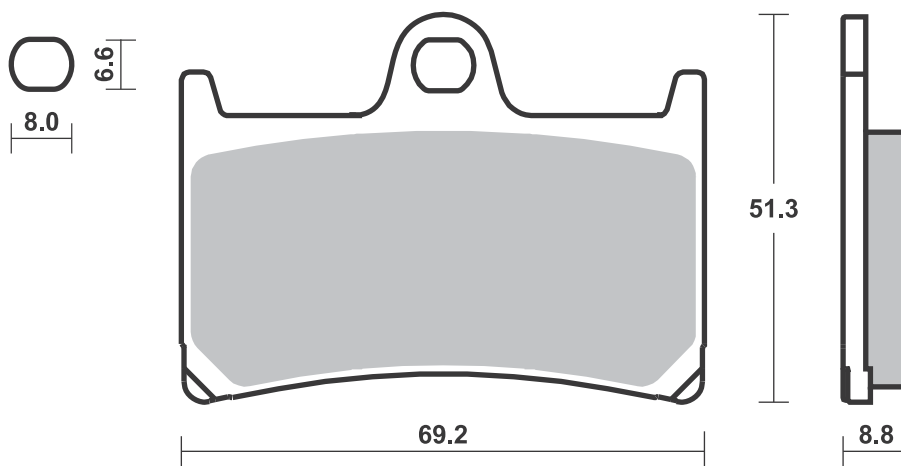



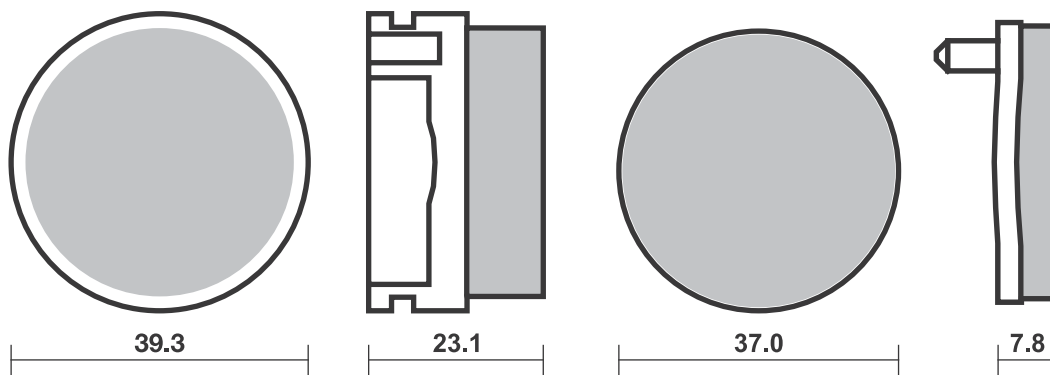
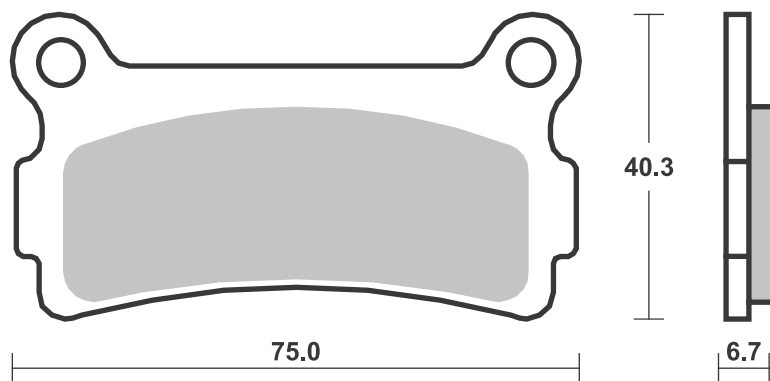





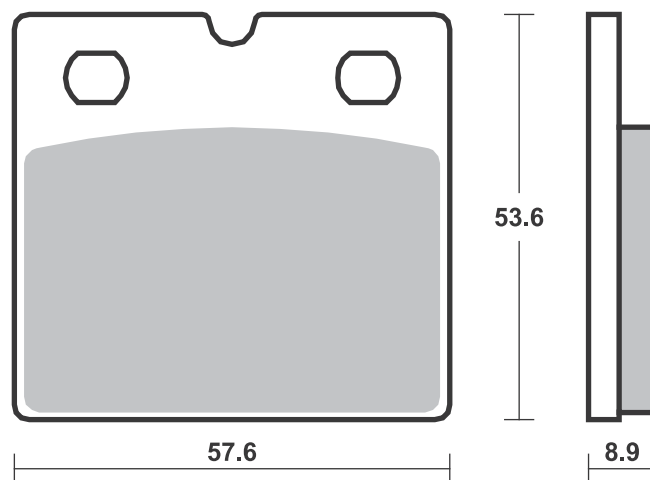
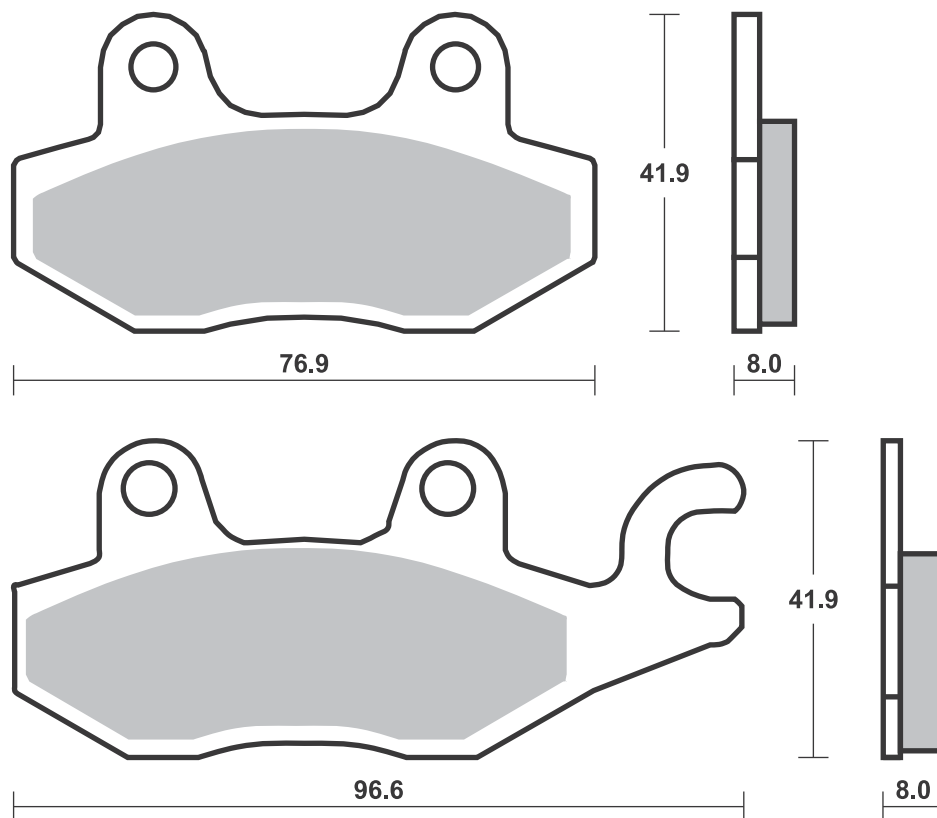



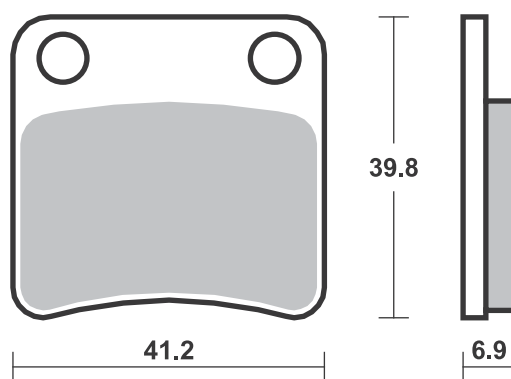
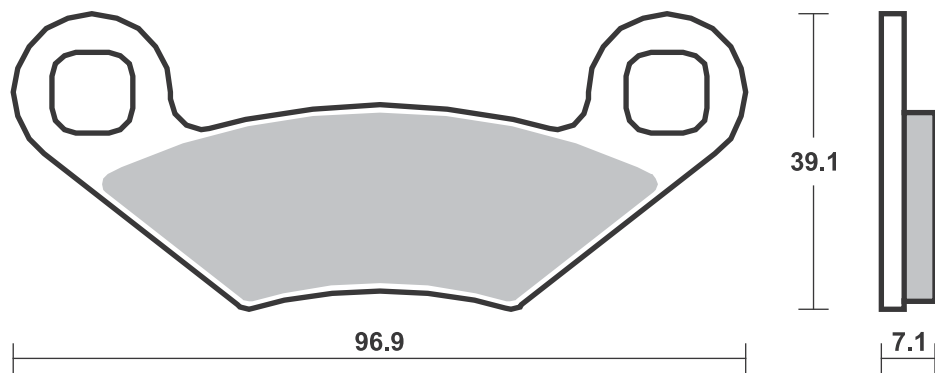
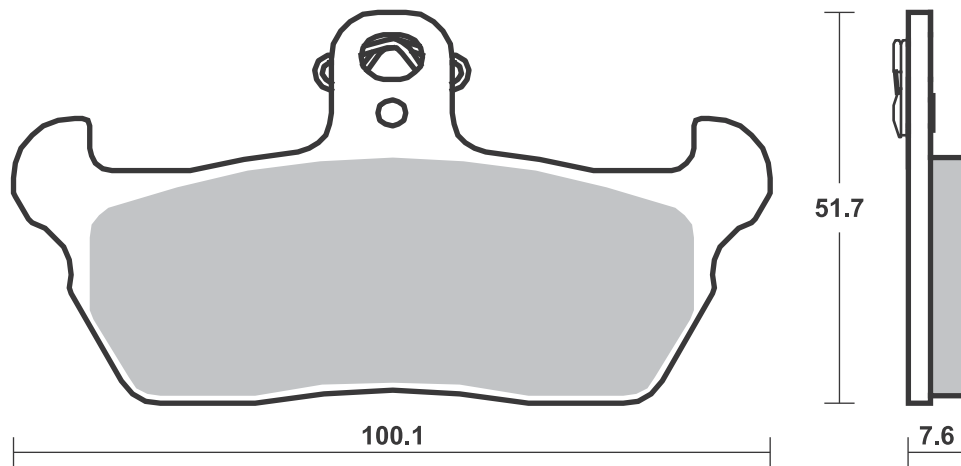

**SBS 644** Recommended compound



<b>BMW</b>			
R80	800 R	91-95	<b>HS</b>
K1	1000	89	<b>HS</b>
K100	1000 LT	92-94	<b>HS</b>
K100	1000 RS	90-92	<b>HS</b>
R100	1000 R	91-95	<b>HS</b>
K1100	1100 LT/SE	92-00	<b>HS</b>
K1100	1100 RS	93-96	<b>HS</b>
R1100	1100 RS	93	<b>HS</b>

**SBS 645** Recommended compound



<b>YAMAHA</b>			
FZR	600 R	90-91	<b>HS</b>
YZF	600 R	94-96	<b>HS</b>
FZR	1000 EX UP	90-91	<b>HS</b>
V-MAX	1200	93-03	<b>HS</b>

**SBS 647** Recommended compound



<b>CAGIVA</b>			
	900 Canyon I.E.	97	<b>HS</b>
<b>HONDA</b>			
VT	600 C, Shadow	88-93	<b>HS</b>
NX	650 Dominator		
	J-K	88-92	<b>HS</b>
GL	1500 Gold Wing		
	Aspencade,		
	Interstate, SE	94-00	<b>HS</b>
GL	1500 Gold Wing,		
	Gold Wing SE	88-99	<b>HS</b>

Brake Pad 1:1 Drawings, Compounds, Fitments

Available compounds **HF • HS**

**SBS 644**

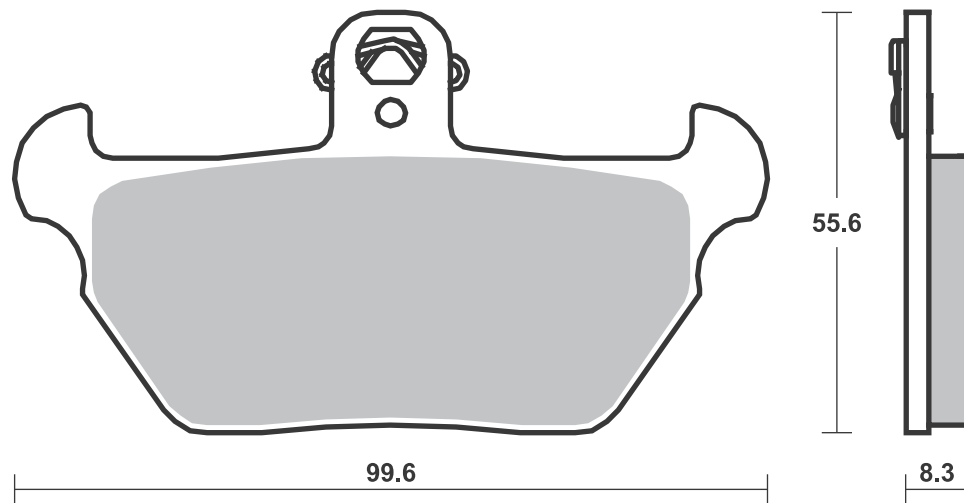

Available compounds **HF • HS • DCC • RS**

**SBS 645**

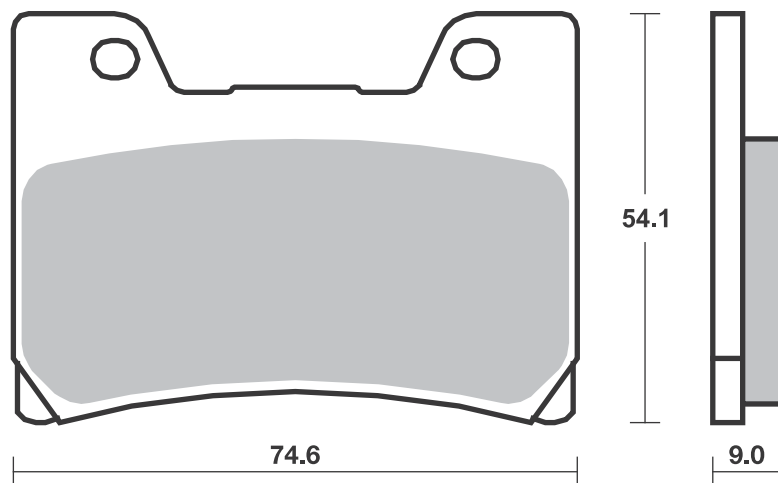

Available compounds **HF • HS**

**SBS 647**

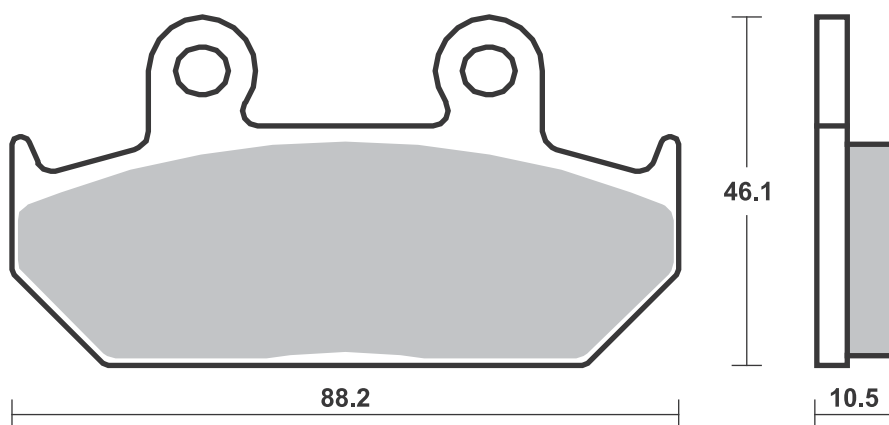

**SBS 648** Recommended compound



<b>SUZUKI</b>			
RM	125	91-95	<b>RSI</b>
DR-Z	250	01-07	<b>SI</b>
RM	250	91-95	<b>RSI</b>
RMX	250	89-98	<b>RSI</b>
DR	350	90-99	<b>HF</b>
DR	350 V, W, X	97-99	<b>SI</b>
DR	650 SE T-W	96-99	<b>HF</b>

<b>YAMAHA</b>			
YZ	125	96-97	<b>RSI</b>
YZ	250 B1-J1	91-97	<b>RSI</b>
WR	400 F	98	<b>SI</b>
YZ	400	98	<b>RSI</b>

**SBS 649** Recommended compound



<b>ARCTIC CAT</b>			
	400 DVX	04-08	<b>SI</b>

<b>HYOSUNG</b>			
TE	400	05-06	<b>SI</b>
TE	450	07-11	<b>SI</b>

<b>KAWASAKI</b>			
KFX	400	02-05	<b>SI</b>

<b>SUZUKI</b>			
LT	250	88-94	<b>SI</b>
LT-Z	400 Quad Sport	02-15	<b>SI</b>
LT-R	450 Left/Rear	06-12	<b>SI</b>
LT	500	87-95	<b>SI</b>

Brake Pad 1:1 Drawings,  
Compounds, Fitments

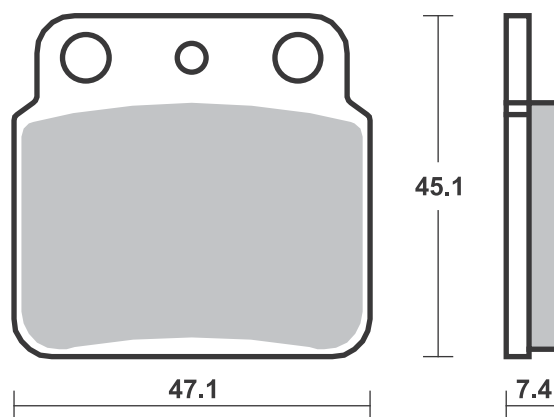
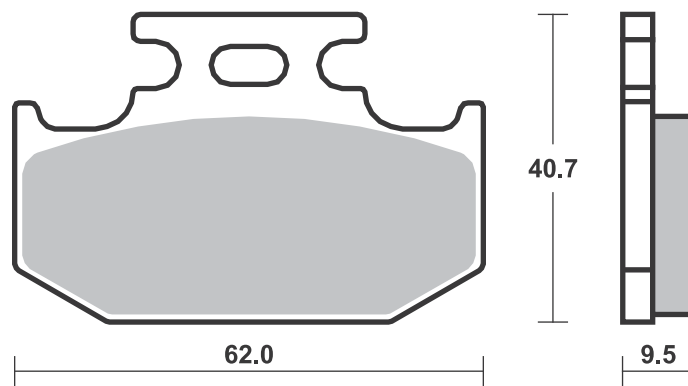





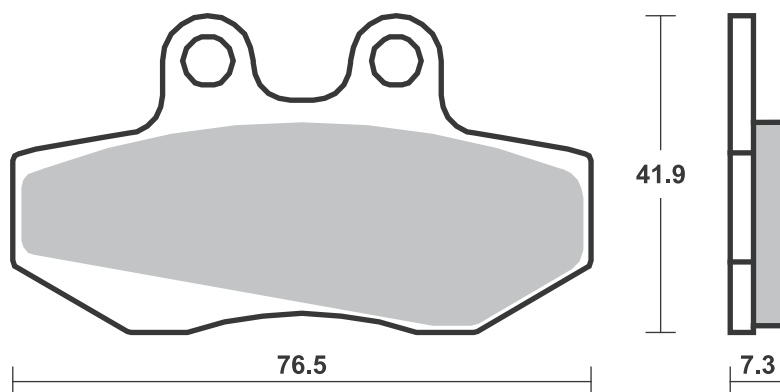
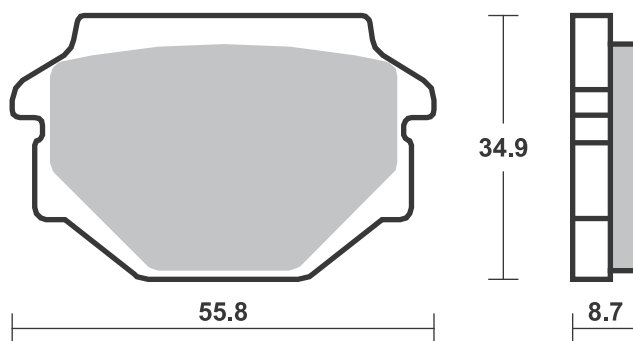
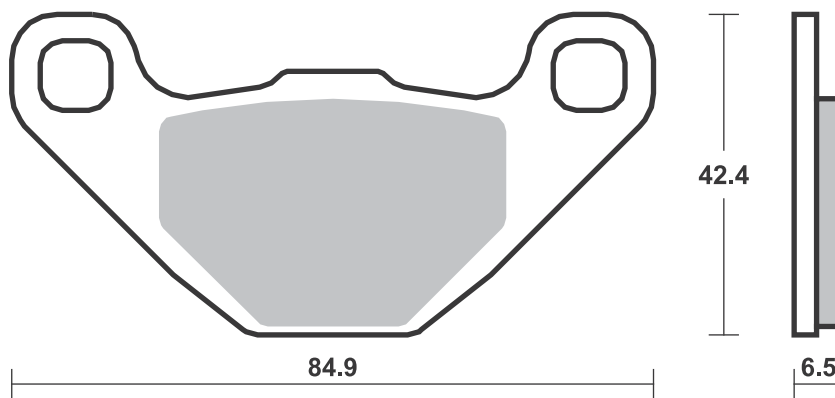



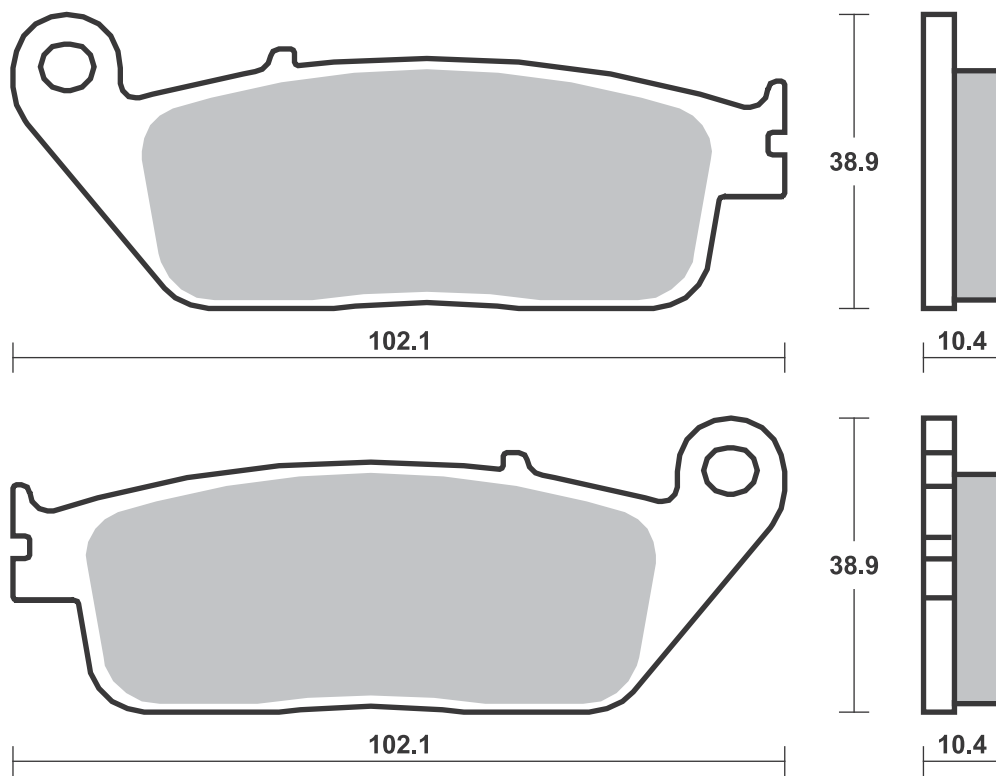

1 set = 6 pcs.

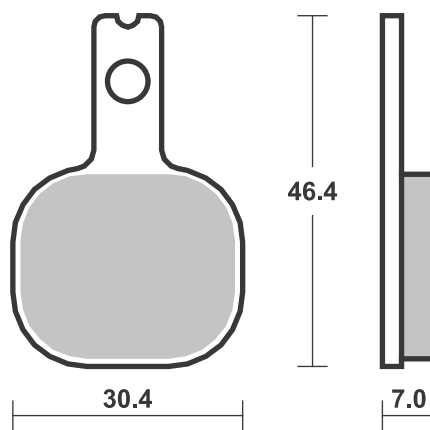

**SBS 656** Recommended compound**HARRISON/BILLET CALIPERS**

Mini-6

**ISR CALIPERS**6 Piston Racing Caliper,  
large**SBS 657** Recommended compound**HONDA**

CB	599	04	LS
CB	600 Hornet ABS	07-12	LS
CBR	600 F ABS	11-13	LS
CBR	600 F, Super Sport	91-94	LS
CBR	600 F3	95-98	LS
CBR	600 F4, F4 Sport	99-06	LS
CBR	600 RR	03-04	LS
CBR	600 RR	05-06	LS
FMX	650	05-08	LS
NT	650 V Deauville	01	LS
NC	700 D Integra	12-13	LS
NC	700 SA ABS	12-13	LS
NC	700 SD ABS	12-13	LS
NC	700 XA ABS	12-13	LS
NC	700 XD ABS	12-13	LS
CB	750 N, F, Seven Fifty	92-95	LS
CBR	900 RR	98-99	LS
CBR	900 RR Fireblade	92-97	LS
	919	02	LS
CBR	929 RR	00-01	LS
CBR	954 RR	02-03	LS
CB	1000 F (Big One)	93-97	LS
CBR	1000 RR Fireblade	04-05	LS
CRF	1000 L Africa Twin	16-18	LS
CRF	1000 L Africa Twin Adventure Sports	18-	LS
RVT	1000 RC51	00-06	LS
VTR	1000 SP-1, SP-2	00-06	LS
VTR	1000 Super Hawk	97-07	LS
CB	1100 , EX	14-18	LS
CB	1100	13	LS
CB	1100 EX ABS	17-18	LS
CB	1100 RS ABS	17-18	LS
VT	1100 C2 Shadow A.C.E.	95-04	LS
VT	1100 C2 Shadow Sabre	00-05	LS
VT	1100 C3 Shadow Aero	98-04	LS
VT	1100 T Shadow	98-04	LS
CB	1300	05-13	LS
CB	1300 S	11-15	LS
VT	1300 CX A Fury	10-18	LS

**HONDA**

VT	1300 Interstate	11-15	LS
VT	1300 Sabre	11-13	LS
VT	1300 Stateline	11-16	LS
VTX	1300 C	04-09	LS
VTX	1300 S	03-07	LS
<b>KAWASAKI</b>			
EN	650 Vulcan S	15-18	LS
EN	650 Vulcan S Cafe	17-18	LS
EN	650 Vulcan S SE	17-18	LS
EX	650 Ninja ABS	17-18	LS
EX	650 Ninja KRT ABS	17-18	LS
Z	650 ABS	17-18	LS
Z	750 , ABS	07-12	LS
Z	900 RS	18-	LS
Z	900 RS Cafe	18-	LS
KLE	1000 Versys	12-18	LS
KLE	1000 Versys ABS	15-16	LS
KLE	1000 Versys LT	15-16	LS
KLV	1000 Left/Rear	04-07	LS
Z	1000	07-09	LS

**SUZUKI**

DL	250 V-Strom	17-18	HF
GSX-R	250	17-18	HF
GW	250 Inazuma	12-18	LS
GW	250 Inazuma F	15-18	LS
DL	650 V-Strom Left/Rear	04-13	LS
DL	650 V-Strom Left/Rear	17-18	LS
DL	650 V-Strom XT Left/Rear	15-18	LS
GSF	650 Bandit	07-11	LS
GSF	650 Bandit / S Bandit Left/Rear ABS	06	LS
GSF	650 Bandit ABS	07-12	LS
GSF	650 S Bandit	07-11	LS
GSF	650 S Bandit ABS	07-13	LS
GSX	650 F	08-18	HF
SV	650 ,S ABS	07-10	LS
SV	650 ,S ABS	15-18	LS
SV	650 ,S Left/Rear	03-12	LS
GSR	750 Left/Rear	11-16	LS

**SUZUKI**

GSX-S	750	17-18	LS
GSX-S	750 Left/Rear	15-16	LS
GSX-S	750 Z Left/Rear	15-16	LS
DL	1000 V-Strom Left/Rear	02-13	LS
GSX-S	1000	15-18	LS
GSX-S	1000 F	15-18	LS
SV	1000 , S	03-07	LS
GSF	1200 Bandit	06	LS
GSF	1200 S Bandit	06	LS
GSF	1250 A Bandit	07-18	LS
GSF	1250 Bandit	06-18	LS
GSF	1250 F Bandit	12-18	LS
GSF	1250 S Bandit	06-18	LS
GSF	1250 SA Bandit	07-18	LS
GSX	1250 FA Bandit	16-18	LS
GSX	1250 FA Traveller	15-16	LS
	1300 B-King	07	LS

**YAMAHA**

FZ6	600	04-08	LS
FZ6	600 Fazer	04-08	LS
FZ6	600 Fazer S2	07-09	LS
FZ6	600 Fazer S2 ABS	07-09	LS
FZ6	600 S2	07-09	LS
FZ6	600 S2 ABS	07-09	LS
YZF	600 R6	03-04	LS
YZF	600 R6	05-16	LS
FZ-07	700	14-17	LS
MT-07	700	18-	LS
	800 Fazer 8	10-15	LS
FZ8	800	10-14	LS
FJ-09	850	15-17	LS
FZ-09	850	14-17	LS
MT-09	850	18-	LS
XSR	900	16-18	LS
XSR	900 Abarth	17-18	LS
FZ1	1000 Fazer	06-16	LS
FZ-10	1000	16-17	LS
MT-10	1000	18-	LS
YZF	1000 R1	04-06	LS
YZF	1000 R1(4-pad)	07-14	LS
YZF	1000 R1(4-pad) ABS	12-14	LS
YZF	1000 R1 LE	06	LS

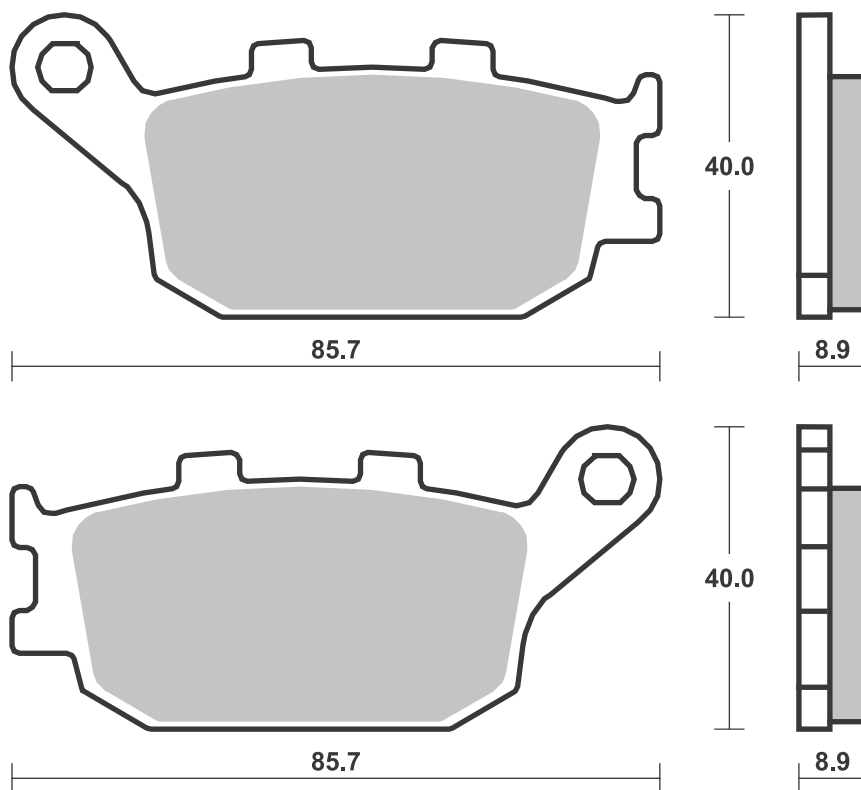
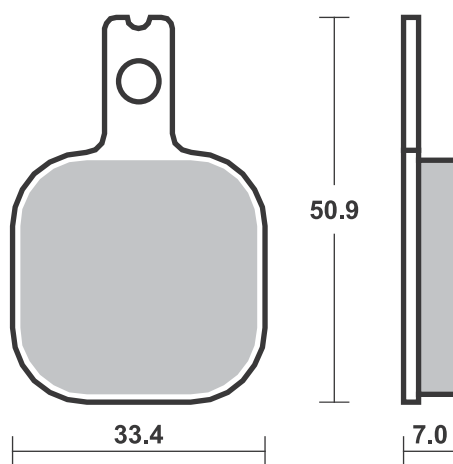





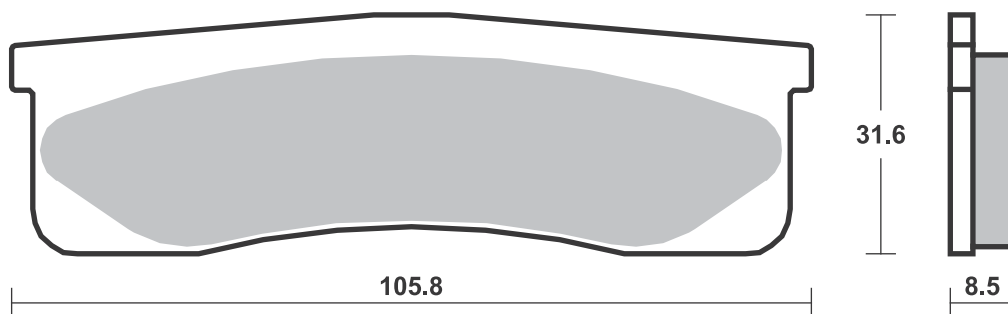
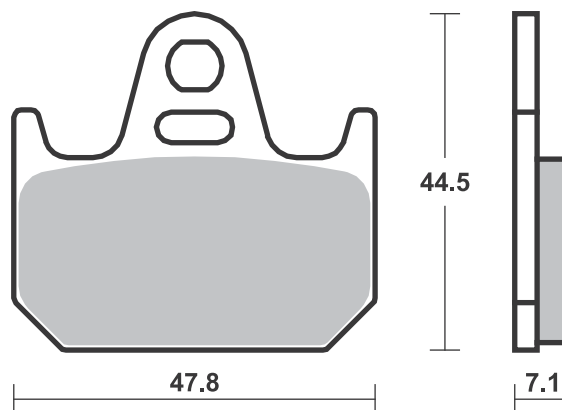
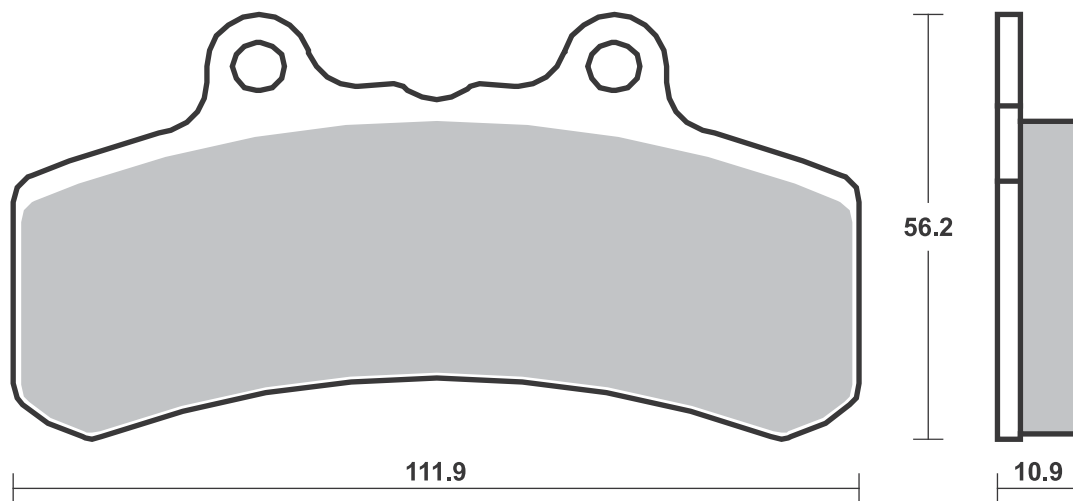



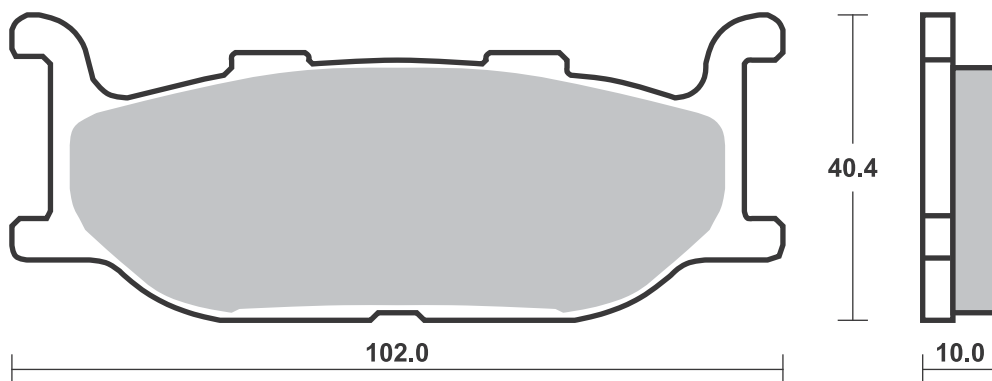
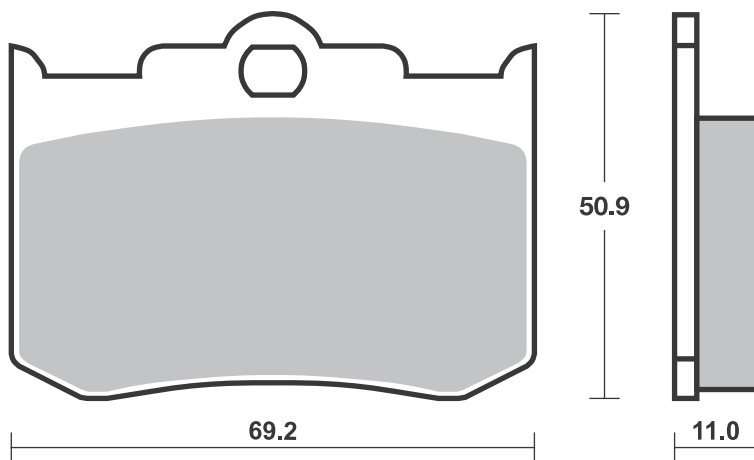
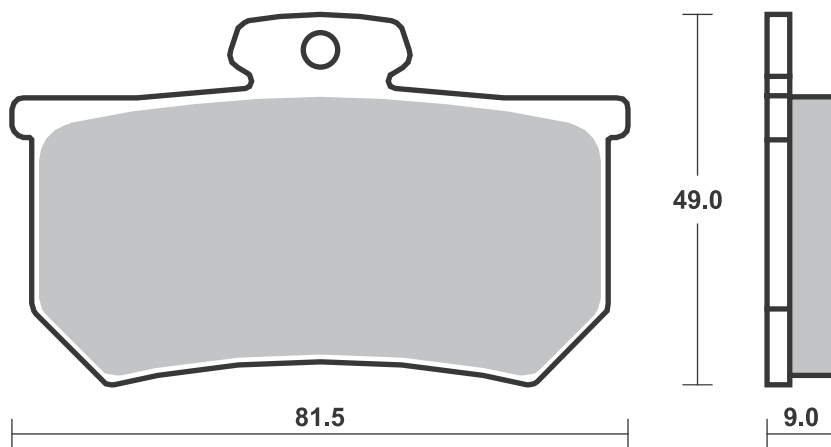



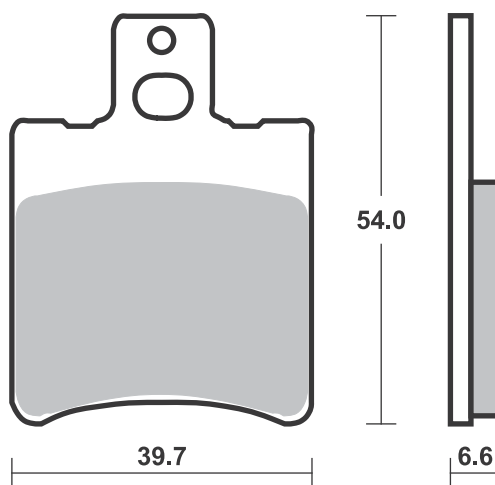
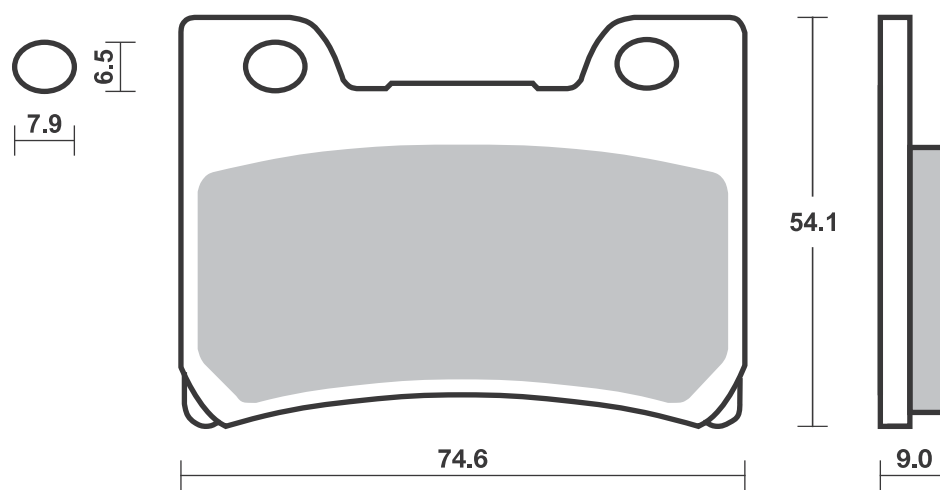



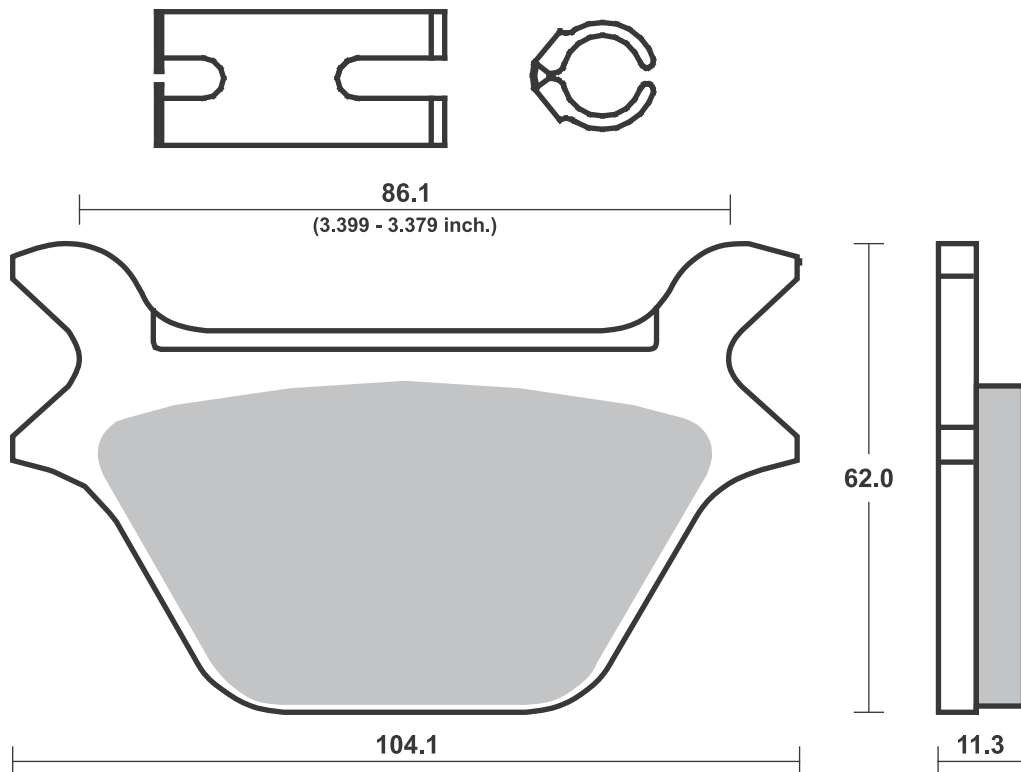
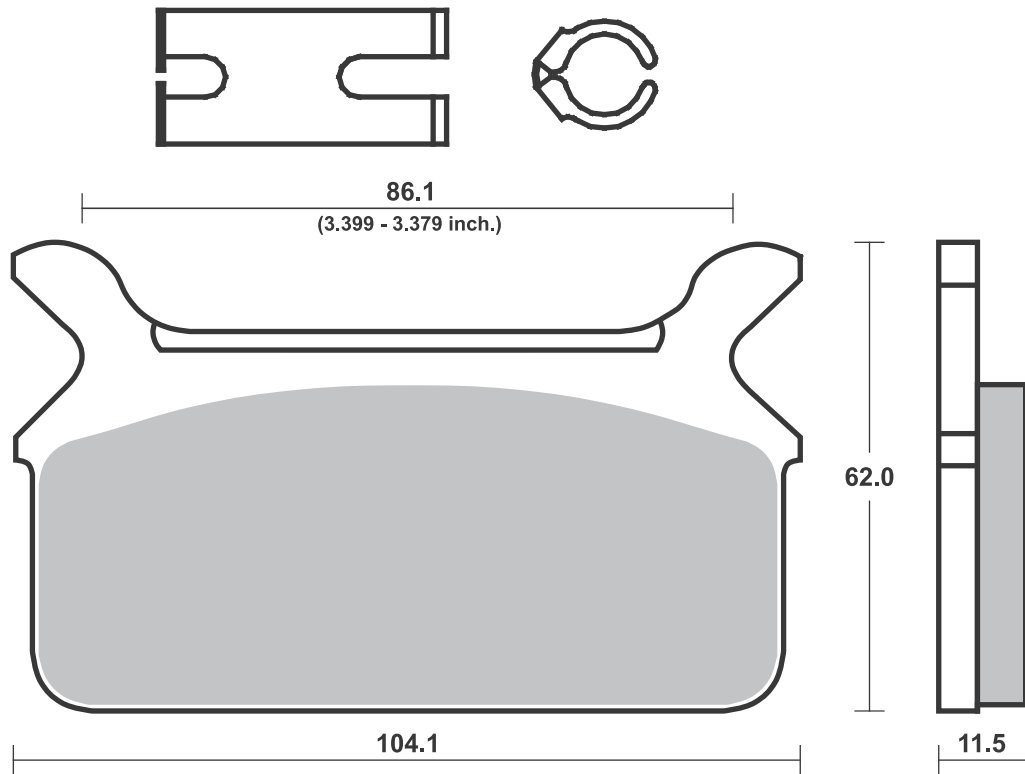

## SBS 671 Recommended compound



APRILIA			
SX	125	08-13	HF
RST	1000 Futura	01-03	LS

BENELLI			
BX	505 Enduro	08	SI

BIMOTA			
DBX	1100	13-18	LS

BMW			
G	450 X	08-10	SI
	1200 HP2 Enduro	04-06	LS
	1200 HP2 Sport	08-10	LS
K	1200 GT (K44)		
	With Integral		
	ABS	04-08	LS
R	1200 Nine-T	14-18	LS
R	1200 Nine-T Pure	17-18	LS
R	1200 Nine-T Racer	17-18	LS
R	1200 Nine-T		
	Scrambler	16-18	LS
R	1200 Nine-T		
	Urban GS	17-18	LS
K	1300 GT	09-10	LS

BREMBO RACING CALIPERS			
Floating Motocross			
Caliper 22.5930.62			
Off Road 122A99021,			
P2 24			
Off Road XQ21361,			
P2 28			

CAGIVA			
	900 Elefant	93-97	HF HF

CCM			
	450 MX	08-10	RSI
GP	450	16	SI
604	600 RS	01	HF
604E	600 Sport	99-01	SI
604E	600 Supermoto	99-01	SI
C25	600	96-98	SI
	644 DS	03-06	HF
	644 R30	02-06	HF

DUCATI			
	620 Multistrada	05-06	HS
	695 Monster	07-12	HS
	800 Monster S2R	05-07	HS
	800 Monster S2R		
	ABS	05-07	HS
	950 Multistrada	17-18	LS
	1200 Multistrada	15-16	LS
	1200 Multistrada		
	Enduro	16-18	LS
	1200 Multistrada		
	Enduro Pro	18-	LS
	1200 Multistrada S	15-17	LS
	1200 Multistrada S		
	D-air	15-17	LS
	1200 Multistrada S		
	Pikes Peak	16-17	LS
	1260 Multistrada	18-	LS
	1260 Multistrada S	18-	LS
	1260 Multistrada S		
	D-air	18-	LS



DUCATI			
	1260 Multistrada S		
	Pikes Peak	18-	LS

GAS GAS			
	50 Wild HP	04-07	SI SI
EC	125	97-99	SI
	200 Wild HP	08-09	SI SI
EC	200	99	SI
	240 Wild HP	04-06	SI SI
	250 Wild HP	08	SI SI
EC	250	97-99	SI
MC	250	97-99	RSI
	300 Wild HP	03-05	SI SI
EC	300	99	SI
	450 Wild HP	03-09	SI SI
	515 Wild HP	09	SI SI

HARLEY DAVIDSON			
XG	500 Street	16-18	H.HF
XG	750 Street	16-17	H.HF
XG	750 Street Rod	18-	H.HF

HIGHLAND			
	450 MX	06-09	RSI
	950 V2 Motard	00-08	HF
	950 V2 Outback	99-08	HF

HUSABERG			
	all models	93-98	SI
TE	125	13	SI
FE	250	13	SI
TE	250	11-13	SI
TE	300	11-13	SI
FE	350	13	SI
FE	390	10-13	SI
FC	400	99-02	RSI
FE	400 ,S,E	99-03	SI
FC	450	03-08	RSI
FE	450	09-13	SI
FE	450 e	04-08	SI
FX	450 e	03-08	RSI
FC	470 , e	01-02	RSI
FX	470 e	01-02	RSI
FC	501	99-01	RSI
FE	501 ,S,E	99-04	SI
FE	501	13	SI
FC	550	01-05	RSI
FE	550 e	04-08	SI
FE	570	09-13	SI
FC	600	99-01	RSI
FE	600 ,S,E	99-02	SI
FE	650 e	01-08	SI
FX	650 e	01-05	RSI

HUSQVARNA			
CR	125	96-13	RSI
SM	125 S	09-13	HF
SM	125 S 4T	11-13	HF
SM	125 Supermotard,		
	S	99-13	HF
TC	125	14-18	RSI
TE	125	14-16	SI
TE	125 4T	11-13	HF
TX	125	17-18	SI
WR	125	96-13	SI
WRE	125	96-13	SI
CR	250	96-05	RSI



HUSQVARNA			
FC	250	14-18	RSI
FE	250	14-18	SI
TC	250	02-18	RSI
TE	250	02-18	SI
TE	250 4T	10-13	SI
WR	250	96-13	SI
TC	300	14-15	RSI
TE	300	14-18	SI
WR	300	09-13	SI
TE	310 4T	10-13	SI
FC	350	14-18	RSI
FE	350	14-18	SI
TE	350	96-13	SI
WR	360	98-13	SI
TE	400	01-13	SI
TE	410	96-13	SI
TC	449	11-13	RSI
TE	449	11-13	SI
FC	450	14-18	RSI
FE	450	14-18	SI
TC	450	02-10	RSI
TE	450	02-10	SI
TE	450	14	SI
FE	501	14-18	SI
TC	510	02-10	RSI
TE	510	02-10	SI
TE	510 Centennial	04-05	SI
TE	511	11-14	SI
TC	570	01-13	RSI
TE	570	01-13	SI
TC	610	96-13	RSI
TE	610 Rallye	96-13	RSI
TE	630	10-13	HS
TE	630	14	SI

KTM			
	most models	94	SI
	125 SuperMoto	00-03	HF
EXC	125 Enduro	99-15	SI
EXE	125	00	HF
GS	125	92-97	SI
LC2	125	99	HF
MX	125	92-93	SI
SX	125	96-18	RSI
SX	144	07-08	RSI
SX	150	09-18	RSI
XC	150	10-14	RSI
EXC	200 Enduro	99-16	SI
SX	200	03-04	RSI
XC	200	06-09	RSI
XC-W	200	06-16	RSI
EXC	250 Enduro	99-08	SI
EXC	250 Enduro 4T	99-06	SI
EXC	250 TPI	18-	SI
EXC-F	250 Enduro	07-18	SI
MX	250	92-93	SI
SX	250	96-18	RSI
SX-F	250	06-18	RSI
XC	250	06-14	RSI
XC-W	250	08-17	RSI
EXC	300	93-96	SI
EXC	300 Enduro	99-08	SI
EXC	300 TPI	18-	SI
MX	300	92	SI
XC	300	06-14	RSI
XC-W	300	06-08	RSI
EXC-F	350	11-18	SI



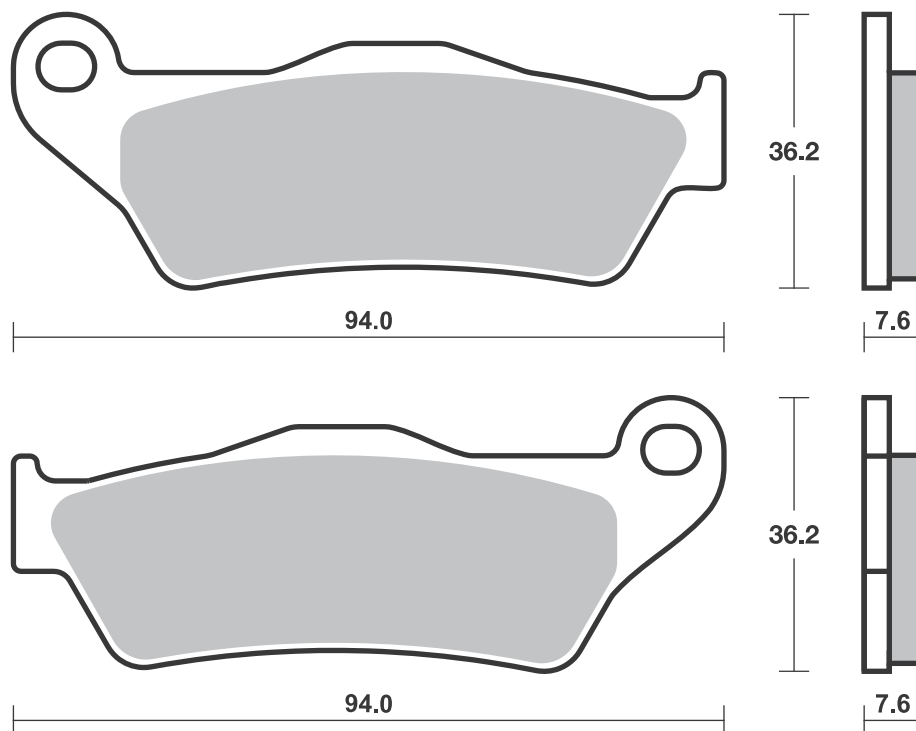



KTM			
SX-F	350	11-18	RSI
XC-F	350	12-17	RSI
XCF-W	350	13-17	RSI
MX	360	96-97	SI
SX	360	96-97	RSI
XC	360	96-97	SI
EXC	380 Enduro	99	SI
MX	380	98	SI
SX	380	98-02	RSI
XC	380	98-03	SI
EXC	400 Racing	00-07	SI
LC4	400	93-02	SI
LC4-E	400 Enduro	99-02	SI
SC	400	99-00	SI
SX	400 Racing	00-02	RSI
SXC	400 Tiainen		
	Replica	99-00	SI
XC-W	400	07-10	RSI
EXC-F	450 Racing	04-18	SI
SX-F	450	03-18	RSI
XC-F	450	06-17	RSI
XCF-W	450	07-15	RSI
EXC-F	500	12-18	SI
MX	500	92-93	SI
XCF-W	500	12-17	RSI
SX	505 Racing	07-09	RSI
XC-F	505	08-09	RSI
EXC	520 Racing	00-02	SI
SX-F	520 Racing	00-02	RSI
EXC	525 Racing	03-06	SI
SX-F	525 Racing	03-06	RSI
XC-F	525	07	RSI
XCF-W	525	07	RSI
EXC	530 Racing	08-11	SI
XCF-W	530	09-11	RSI
SXC	540 Tiainen		
	Replica	99-00	SI
LC4	600 Six Days	92	SI
LC4	620 Competition	99-02	SI
LC4	620 Competition		
	SuperMoto	00-01	HF
LC4	620 RXC	95	SI
LC4	620 Supercompetition		
		01	HF
SC	620	99-00	SI
SX	620	95-99	RSI
LC4	625 SC		
	Supermoto	02-04	HF
SXC	625	03-04	HF
LC4	640 Adventure	99-04	HF
LC4-E	640 Enduro	99-04	HF
LC4-E	640 Supermoto	99-02	HF
LC4	660 Rallye	01-03	HF
	790 Duke	18-	HS
	950 R		
	Superenduro	06-08	LS
	950 SM	05-07	LS
	950 SM R	07-09	LS
	990 Adventure R	10-12	LS
	990 Adventure,		
	Adventure S,		
	ABS	06-11	LS
	990 Supermoto	07-11	LS
	990 Supermoto R	10	LS
	990 Supermoto T	09-13	LS
	1050 Adventure	15-16	LS



KTM			
	1090 Super		
	Adventure	17-18	LS
	1090 Super		
	Adventure R	17-18	LS
	1190 Adventure	13-16	LS
	1290 Super		
	Adventure	15-18	LS
	1290 Super		
	Adventure R	17-18	LS
	1290 Super		
	Adventure S	17-18	LS
	1290 Super		
	Adventure T	17-18	LS
MAICO			
	250 Motocross/		
	Enduro	99-01	SI
	500 Motocross/		
	Enduro	99	SI
	500 Supermotard	99	HF
MOTO-GUZZI			
ES	1100 Quota	99-03	HF
V	1100 Brevia, ABS	05-07	LS
	1200 Griso 8V	07-13	LS
	1200 Griso 8V SE	18-	LS
	1200 Norge	06-14	LS
	1200 Norge GT 8V	10-13	LS
	1200 Sport	07-08	LS
	1200 Sport 8V	12-13	LS
	1200 Sport 8V SE	12-15	LS
	1200 Stelvio	08-11	LS
	1200 Stelvio 8V SE	12-16	LS
	1200 Stelvio NTX	09-11	LS
V	1200 Brevia	08-13	LS
MOTO-MORINI			
	1200 Granferro	10	LS
	1200 Granpasso	08-13	LS
	1200 GT	10	LS
	1200 Scrambler	09-10	LS
SHERCO			
SE-R	125	17	SI
SE	250 , R	14	SI
SE	250 2.5i Enduro	06-11	SI
SE	250 F, F-R	14-18	SI
SE	250 i/iR	12-13	SI
SE	250 i-F	13	SI
SX	250 2.5i-F	09-11	RSI
SCF-R	300	16-18	SI
SE	300 , R	14-18	SI
SE	300 3.0i-F	10-11	SI
SE	300 F, F-R	14-18	SI
SE	300 i/iR	12-13	SI
SE	300 i-F	13	SI
SE	450 4.5i Enduro	04-11	SI
SE	450 F, F-R	14-18	SI
SE	450 iR	12-13	SI
SE	510 5.1i Enduro	06-11	SI
SE	510 iR	12-13	SI
SWM			
RS	300 R	15-18	SI
RS	500 R	15-18	SI



TM			
	80 Cross	96-00	RSI
MX	85	01-12	RSI
	125	96-17	RSI
	125 Enduro	01-17	SI
	250	01-05	RSI
	250 E	95-00	RSI
	250 Enduro	01-15	SI
	250 F	01-17	RSI
	250 F Enduro	00-17	SI
	300	98-05	RSI
	300 Enduro	01-05	SI
	320	96-97	RSI
	400 F	00-01	RSI
	400 F Enduro	01	SI
	450 F	02-17	RSI
	450 F Enduro	02-17	SI
FT	450 Fi	17	RSI
	530 F	01-05	RSI
	530 F Enduro	01-05	SI
TRIUMPH			
	800 Tiger XCA	18-	HS
	800 Tiger XCX	18-	HS
	800 Tiger XRT	18-	HS
	800 Tiger XRX	18-	HS
	800 Tiger XRX		
	Low	18-	HS
	1200 Bonneville		
	Bobber Black	18-	HS
	1200 Speedmaster	18-	HS
VERTEMATI			
C	500 Cross	02-04	RSI
E	501 Enduro	02-04	SI
S	501 Supermotard	02-04	HF
VOR			
	400 Cross	00-01	RSI
	400 Enduro	00-01	SI
EN	400	02-03	SI
MX	400	02	RSI
EN	450	02-04	SI
MX	450	02-04	RSI
	500 492 Enduro	99	SI
	500 495 Cross	99	RSI
EN	530	02-04	SI
MX	530	02-04	RSI
YAMAHA			
XT	660 Z Tenere	08-14	HS
XT	660 Z Tenere		
	ABS	11-14	HS
ZERO			
FX	ZF2.8	15	HS
FX	ZF5.7	15	HS

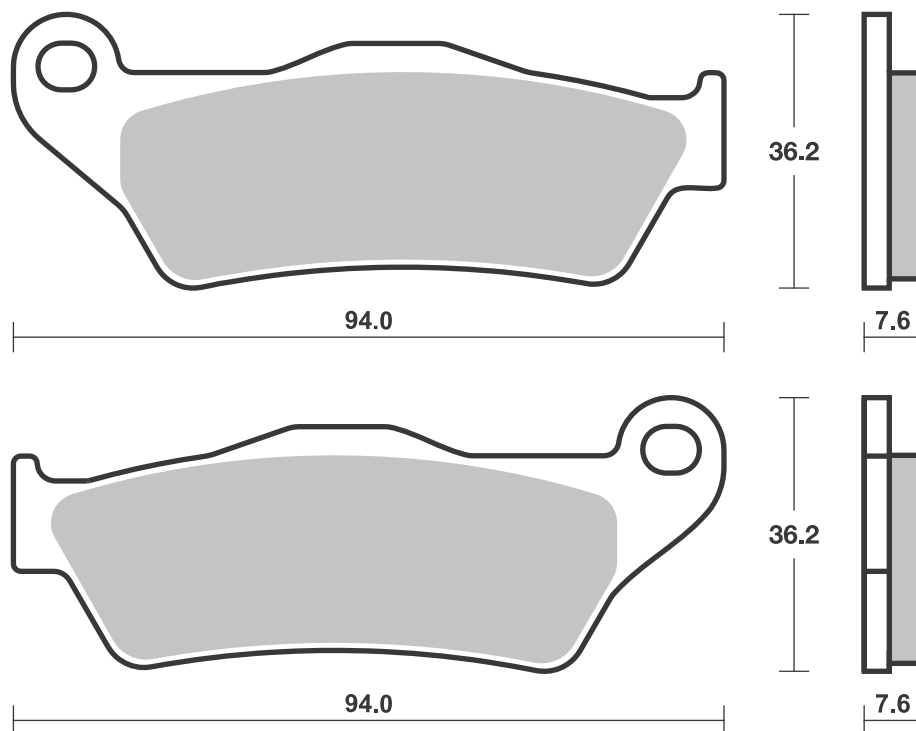



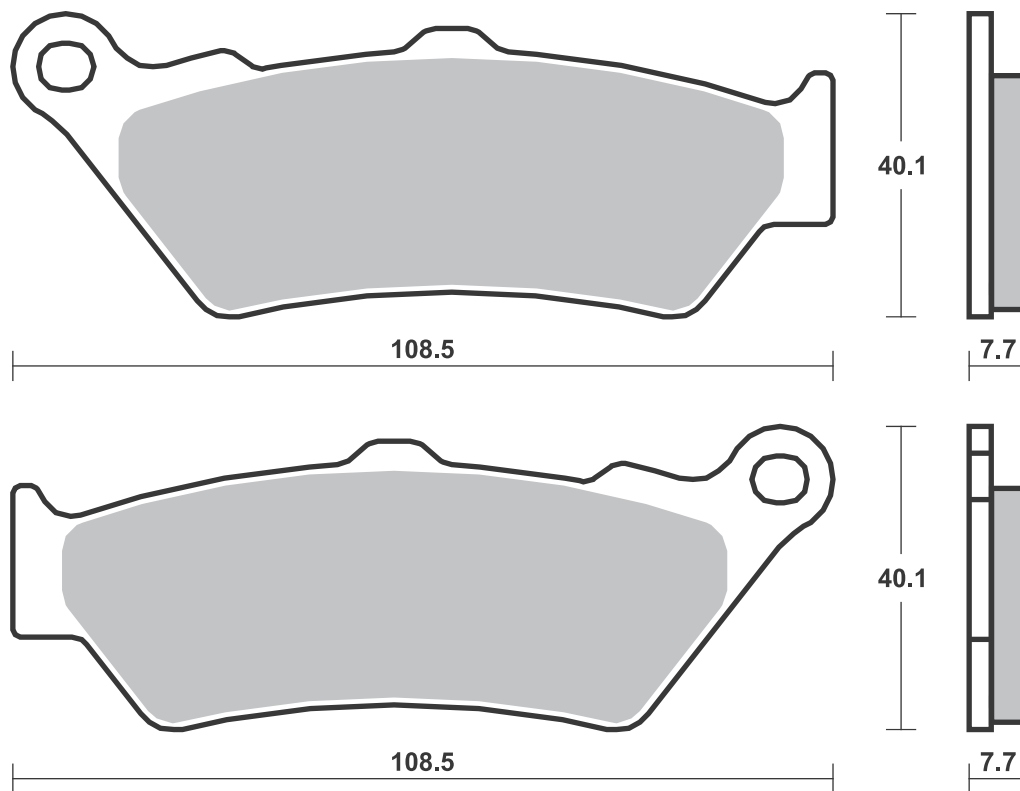
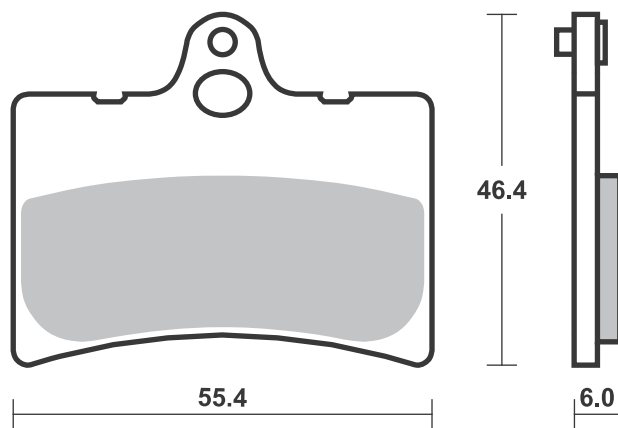

**SBS 674 Recommended compound**

<b>MOTO-GUZZI</b>			
1400 California			
Touring	13-15	<b>LS</b>	
1400 California			
Touring SE	16-17	<b>LS</b>	
1400 Eldorado	15-17	<b>LS</b>	
MGX-21 1400 Flying			
Fortress	15-17	<b>LS</b>	

<b>MOTO-MORINI</b>			
1200 Granpasso	08-13	<b>HS</b>	
1200 GT	10	<b>HS</b>	
1200 Scrambler	09-10	<b>HS</b>	

<b>ROYAL ENFIELD</b>			
535 Continental			
GT	14-17	<b>HS</b>	

<b>SWM</b>			
600 Superdual			
GT Pack	18-	<b>HS</b>	
600 Superdual T	18-	<b>HS</b>	
600 Superdual X	18-	<b>HS</b>	

<b>TRIUMPH</b>			
1600 Thunderbird	09-18	<b>LS</b>	
1700 Thunderbird			
Commander	14-18	<b>LS</b>	
1700 Thunderbird			
LT	14-18	<b>LS</b>	



<b>TRIUMPH</b>			
1700 Thunderbird			
Nightstorm	14-18	<b>LS</b>	
1700 Thunderbird			
Storm	11-18	<b>LS</b>	
2300 Rocket III	04-13	<b>LS</b>	
2300 Rocket III			
Classic	07-13	<b>LS</b>	
2300 Rocket III			
Roadster	10-18	<b>LS</b>	
2300 Rocket III			
Touring	13-14	<b>LS</b>	
2300 Rocket X	15	<b>LS</b>	

<b>VICTORY</b>			
1200 Octane	17	<b>H.HS</b>	
1500 Kingpin	04-05	<b>H.LS</b>	
1500 Touring			
Cruiser	03-06	<b>H.LS</b>	
1500 V92C			
Cruiser	98-02	<b>H.LS</b>	
1500 V92C			
Deluxe	01-02	<b>H.LS</b>	
1500 V92SC			
Sport			
Cruiser	00-02	<b>H.LS</b>	
1500 Vegas	03-05	<b>H.LS</b>	
1500 Vegas			
8-Ball	05	<b>H.LS</b>	
1634 Hammer	05-07	<b>H.LS</b>	
1634 Hammer S	06-08	<b>H.LS</b>	



<b>VICTORY</b>			
1634 Kingpin	06-07	<b>H.LS</b>	
1634 Kingpin			
Tour	06-07	<b>H.LS</b>	
1634 Vegas	06-07	<b>H.LS</b>	
1634 Vegas			
8-Ball	06-07	<b>H.LS</b>	
1634 Vegas			
Jackpot	06-07	<b>H.LS</b>	

<b>YAMAHA</b>			
XT 660 R	04-11	<b>HS</b>	

<b>ZERO</b>			
DS ZF12.5	15	<b>HS</b>	
DS ZF13.0	16-17	<b>HS</b>	
DS ZF9.4	15	<b>HS</b>	
DS ZF9.8	16-17	<b>HS</b>	
DSR ZF13.0	16-17	<b>HS</b>	
FX ZF3.3	16-17	<b>HS</b>	
FX ZF6.5	16-17	<b>HS</b>	
FXS ZF3.3	16-17	<b>HS</b>	
FXS ZF6.5	16-17	<b>HS</b>	
S ZF12.5	15	<b>HS</b>	
S ZF13.0	16-17	<b>HS</b>	
S ZF9.4	15	<b>HS</b>	
S ZF9.8	16-17	<b>HS</b>	
SR ZF12.5	15	<b>HS</b>	
SR ZF13.0	16-17	<b>HS</b>	

**SBS 675 Recommended compound**

<b>APRILIA</b>			
650 Pegaso			
Strada	05-09	<b>LS</b>	
750 Dorsoduro			
Factory	12-13	<b>LS</b>	
SL 750 Shiver GT,			
ABS	09-12	<b>LS</b>	
SL 750 Shiver, ABS	07-18	<b>LS</b>	
SMV 750 Dorsoduro	08-18	<b>LS</b>	
NA 850 Mana	07	<b>LS</b>	
1200 Caponord	13-18	<b>LS</b>	
1200 Caponord			
Rally	15-18	<b>LS</b>	
1200 Caponord			
Travel Pack	16-18	<b>LS</b>	
1200 Dorsoduro,			
ABS	11-14	<b>LS</b>	

<b>BENELLI</b>			
BX 505 Enduro	08	<b>SI</b>	

<b>BMW</b>			
G 310 GS	17-18	<b>LS</b>	
G 310 R	16-18	<b>LS</b>	
F 650 , ST	94-00	<b>HF</b>	
F 650 CS Scarver	02-06	<b>LS</b>	
F 650 GS	08-12	<b>LS</b>	
F 650 GS ABS	01-07	<b>HF</b>	
F 650 GS ABS	08-12	<b>LS</b>	
F 650 GS Dakar	01-07	<b>HF</b>	



<b>BMW</b>			
F 650 GS, Rallye	01-07	<b>HF</b>	
F 650 ST Strada	97-01	<b>HF</b>	
G 650 GS	09-15	<b>LS</b>	
G 650 GS Sertao	12-14	<b>LS</b>	
G 650 Xchallenge	06-07	<b>LS</b>	
G 650 Xcountry	06-09	<b>LS</b>	
G 650 Xmoto	06-07	<b>LS</b>	
F 700 GS	13-16	<b>LS</b>	
F 750 GS	18-	<b>LS</b>	
F 800 GS	08-18	<b>LS</b>	
F 800 GT	13-18	<b>LS</b>	
F 800 R	09-18	<b>LS</b>	
F 800 S	06-10	<b>LS</b>	
F 800 ST	06-12	<b>LS</b>	
F 800 ST Touring	11-12	<b>LS</b>	
F 850 GS	18-	<b>LS</b>	
R 850 RT	96-01	<b>LS</b>	
S 1000 R	13-18	<b>LS</b>	
S 1000 RR	09-18	<b>LS</b>	
S 1000 RR HP4	12-14	<b>LS</b>	

<b>BREMBO RACING CALIPERS</b>			
Motocross Caliper 22.2180.20			

<b>CCM</b>			
GP 450	16	<b>SI</b>	
604 600 RS	01	<b>HF</b>	
604E 600 Sport	99-01	<b>SI</b>	
604E 600 Supermoto	99-01	<b>SI</b>	



<b>CCM</b>			
C25 600	96-98	<b>SI</b>	
644 DS	03-06	<b>HF</b>	
644 R30	02-06	<b>HF</b>	

<b>CF MOTO</b>			
400 NK Efi	17	<b>LS</b>	
650 NK	14-16	<b>LS</b>	
650 NK Efi	17	<b>LS</b>	
650 TK	14-15	<b>LS</b>	

<b>DUCATI</b>			
400 Scrambler			
Sixty Two	16-18	<b>LS</b>	
797 Monster	17-18	<b>LS</b>	
797 Monster+	17-18	<b>LS</b>	
800 Scrambler	17-18	<b>LS</b>	
800 Scrambler			
Classic	15-18	<b>LS</b>	
800 Scrambler			
CR	17-18	<b>LS</b>	
800 Scrambler			
CR Cafe			
Racer	17-18	<b>LS</b>	
800 Scrambler			
Enduro	15-16	<b>LS</b>	
800 Scrambler			
Flat Track Pro	16	<b>LS</b>	
800 Scrambler			
Full Throttle	15-18	<b>LS</b>	

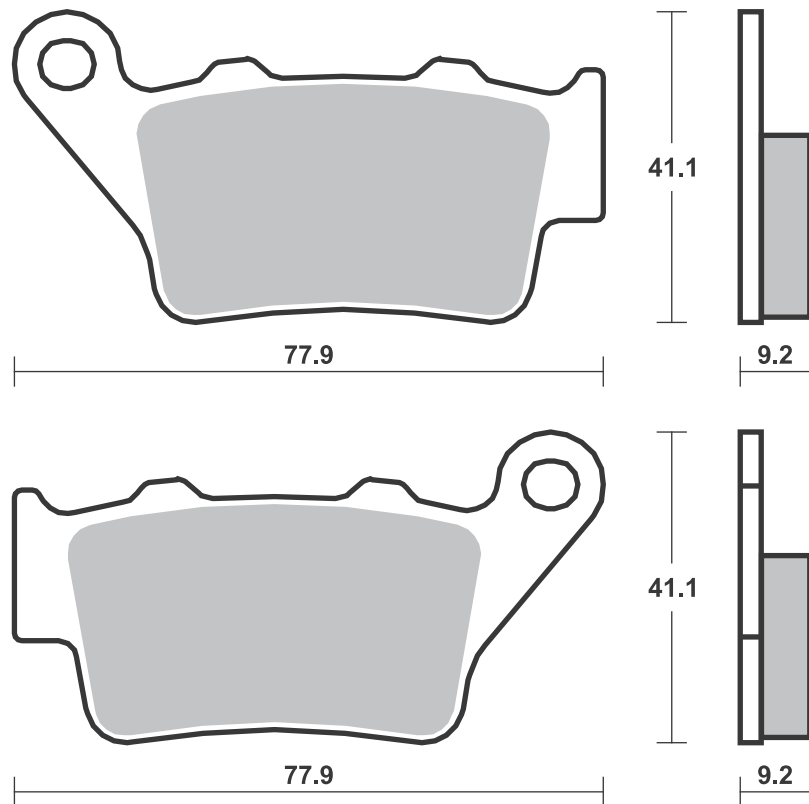
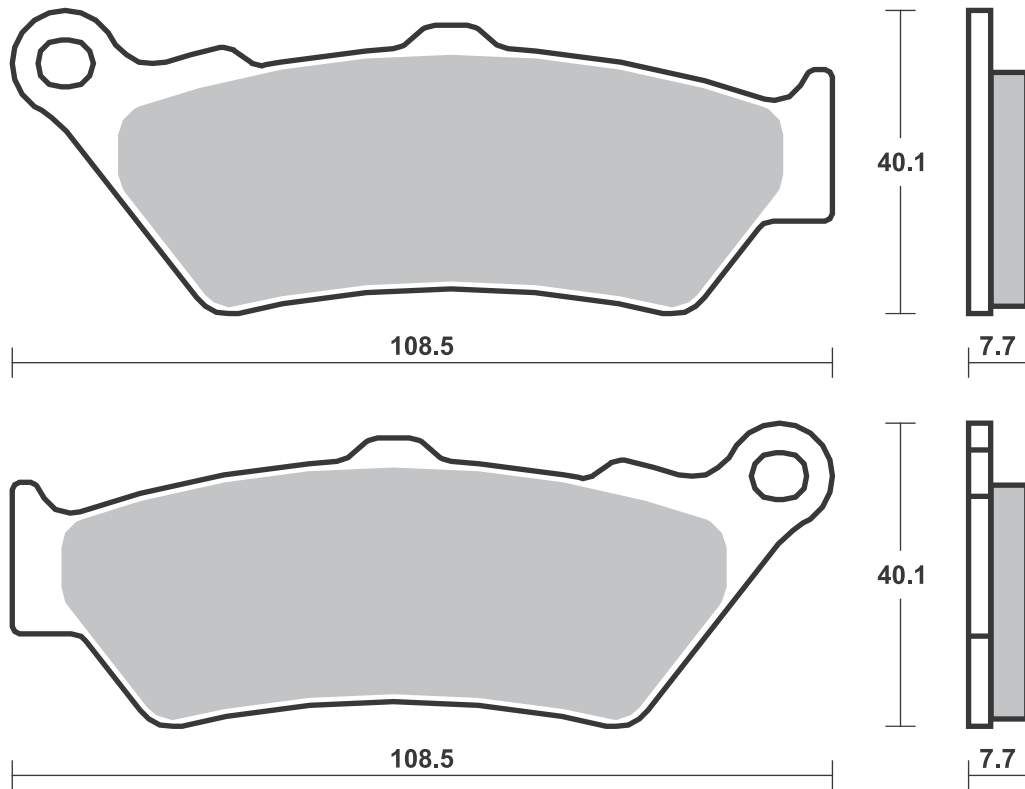



<b>DUCATI</b>			
800 Scrambler			
Icon	15-18	<b>LS</b>	
800 Scrambler			
Mach 2.0	18-	<b>LS</b>	
800 Scrambler			
Street Classic	17-18	<b>LS</b>	
800 Scrambler			
Urban Enduro	16	<b>LS</b>	
800 Scrambler-X			
DS Desert			
Sled	17-18	<b>LS</b>	
1000 Biposto	07-08	<b>LS</b>	
1000 GT	05-10	<b>LS</b>	
1000 GT Touring	09-10	<b>LS</b>	
1000 Paul Smart	05-08	<b>LS</b>	
1000 Sport,			
Sport S	05-09	<b>LS</b>	
1100 Scrambler	18-	<b>LS</b>	
1100 Scrambler			
Special	18-	<b>LS</b>	
1100 Scrambler			
Sport	18-	<b>LS</b>	

<b>FANTIC</b>			
125 Caballero			
Flat Track	17	<b>LS</b>	
500 Caballero	17	<b>LS</b>	

<b>GAS GAS</b>			
EC	125	97-99	<b>SI</b>
EC	200	99	<b>SI</b>
EC	250	97-99	<b>SI</b>
MC	250	97-99	<b>RSI</b>
EC	300	99	<b>SI</b>

<b>HIGHLAND</b>			
450 MX	06-09	<b>RSI</b>	
950 V2 Motard	00-08	<b>HF</b>	
950 V2 Outback	99-08	<b>HF</b>	

<b>HONDA</b>			
CBR	250 R (Bybre cal)	11	<b>LS</b>

<b>HUSABERG</b>			
FC	400	99-02	<b>RSI</b>
FE	400 ,S,E	99-03	<b>SI</b>
FS	400 e, c	01-03	<b>RSI</b>
FC	450	03-08	<b>RSI</b>
FE	450 e	04-08	<b>SI</b>
FS	450 c	06-08	<b>RSI</b>
FS	450 e, c	03-05	<b>RSI</b>
FX	450 e	03-08	<b>RSI</b>
FC	470 , e	01-02	<b>RSI</b>
FX	470 e	01-02	<b>RSI</b>
FC	501	99-01	<b>RSI</b>
FE	501 ,S,E	99-04	<b>SI</b>
FC	550	01-05	<b>RSI</b>
FE	550 e	04-08	<b>SI</b>
FC	600	99-01	<b>RSI</b>
FE	600 ,S,E	99-02	<b>SI</b>
FE	650 e	01-08	<b>SI</b>
FS	650 e, c	01-08	<b>RSI</b>
FX	650 e	01-05	<b>RSI</b>

<b>HUSQVARNA</b>			
CR	125	96-04	<b>RSI</b>
SM	125 S	09-13	<b>HF</b>



<b>HUSQVARNA</b>			
SM	125 S 4T	11-13	<b>HF</b>
SM	125 Supermotard,		
	S	99-13	<b>HF</b>
TE	125 4T	11-13	<b>HF</b>
WR	125	96-13	<b>SI</b>
WRE	125	96-13	<b>SI</b>
CR	250	96-04	<b>RSI</b>
TC	250	02-03	<b>RSI</b>
TE	250	02-13	<b>SI</b>
WR	250	96-13	<b>SI</b>
TE	350	96-13	<b>SI</b>
WR	360	98-13	<b>SI</b>
SM	400 R	02	<b>HF</b>
TE	400	01-13	<b>SI</b>
	401 Svartpilen	17-18	<b>LS</b>
	401 Vitpilen	17-18	<b>LS</b>
TE	410	96-13	<b>SI</b>
SM	450 R	03-04	<b>HF</b>
SM	450 R	05	<b>RSI</b>
TC	450	02-03	<b>RSI</b>
TE	450	02-10	<b>SI</b>
SM	510 R	05	<b>RSI</b>
TC	510	02-03	<b>RSI</b>
TE	510	02-10	<b>SI</b>
TE	510 Centennial	04-05	<b>SI</b>
	570 Nox	01-03	<b>HF</b>
SM	570 R	01-08	<b>HF</b>
TC	570	01-13	<b>RSI</b>
TE	570	01-13	<b>SI</b>
LT	610	00-02	<b>HF</b>
SM	610 Super		
	Motard, S	98-00	<b>HF</b>
TC	610	96-13	<b>RSI</b>
TE	610 Rallye	96-13	<b>RSI</b>
SMR	630	04-08	<b>RSI</b>
TR	650 Strada	13	<b>LS</b>
TR	650 Terra	13	<b>LS</b>
	701 Svartpilen	18-	<b>LS</b>
	701 Vitpilen	18-	<b>LS</b>
FE	701 Enduro	17	<b>LS</b>
SM	701 Supermoto	15-18	<b>LS</b>
	900 Nuda	12-13	<b>LS</b>
	900 Nuda R, ABS	12-13	<b>LS</b>

<b>HYOSUNG</b>			
RX	450 SM	08-11	<b>LS</b>

<b>INDIAN</b>			
	1000 Scout Sixty	17-18	<b>H.LS</b>
	1200 Scout	17-18	<b>H.LS</b>
	1200 Scout		
	Bobber	17-18	<b>H.LS</b>

<b>KTM</b>			
	most models	94	<b>SI</b>
	125 Duke	11-18	<b>LS</b>
	125 Sting	99	<b>HF</b>
	125 SuperMoto	00-03	<b>HF</b>
EXC	125 Enduro	99-03	<b>SI</b>
EXE	125	00	<b>HF</b>
LC2	125	99	<b>HF</b>
RC	125	14-18	<b>LS</b>
SX	125	96-03	<b>RSI</b>
	200 Duke	12-17	<b>LS</b>
EXC	200 Enduro	99-03	<b>SI</b>
RC	200	14-18	<b>LS</b>
	250 Duke	14-15	<b>LS</b>



<b>KTM</b>			
EXC	250 Enduro	99-03	<b>SI</b>
EXC	250 Enduro 4T	99-03	<b>SI</b>
RC	250	14-15	<b>LS</b>
SX	250	96-02	<b>RSI</b>
EXC	300 Enduro	99-03	<b>SI</b>
MX	360	96-97	<b>SI</b>
SX	360	96-97	<b>RSI</b>
XC	360	96-97	<b>SI</b>
EXC	380 Enduro	99	<b>SI</b>
MX	380	98	<b>SI</b>
SX	380	98-02	<b>RSI</b>
XC	380	98-03	<b>SI</b>
	390 Duke	13-15	<b>LS</b>
RC	390	14-18	<b>LS</b>
EXC	400 Racing	00-03	<b>SI</b>
LC4-E	400 Enduro	99-02	<b>SI</b>
SC	400	99-00	<b>SI</b>
SX	400 Racing	00-02	<b>RSI</b>
SXC	400 Tiainen		
	Replica	99-00	<b>SI</b>
	450 Rally	11-16	<b>SI</b>
EXC	520 Racing	00-02	<b>SI</b>
SX-F	520 Racing	00-02	<b>RSI</b>
EXC	525 Racing	03	<b>SI</b>
SX-F	525 Racing	03	<b>RSI</b>
SXC	540 Tiainen		
	Replica	99-00	<b>SI</b>
LC4	620 Competition	99-02	<b>SI</b>
LC4	620 Competition		
	SuperMoto	00-01	<b>HF</b>
LC4	620 RXC	95	<b>SI</b>
LC4	620 Supercompetition		
		01	<b>HF</b>
SC	620	99-00	<b>SI</b>
SX	620	95-99	<b>RSI</b>
LC4	625 SC		
	Supermoto	02-04	<b>HF</b>
SMC	625	05-06	<b>HF</b>
SXC	625	03-04	<b>HF</b>
	640 Duke	03-06	<b>HF</b>
LC4	640 Adventure	99-07	<b>HF</b>
LC4	640 Supermoto	03-04	<b>HF</b>
LC4-E	640 Enduro	99-04	<b>HF</b>
LC4-E	640 Supermoto	99-02	<b>HF</b>
LC4	660 Rallye	01-03	<b>HF</b>
LC4	660 SM Factory		
	Replica	02	<b>RSI</b>
SMC	660 Supermoto	03-07	<b>HF</b>
	690 Duke	08-11	<b>LS</b>
	690 Duke ABS	12-18	<b>LS</b>
	690 Duke R	10-11	<b>LS</b>
	690 Duke R	14-17	<b>LS</b>
	690 Enduro	08-14	<b>LS</b>
	690 Enduro R	09-17	<b>LS</b>
	690 SM	07-11	<b>LS</b>
	690 SMC	08-10	<b>LS</b>
	690 Supermoto		
	R	08-09	<b>LS</b>
	790 Duke	18-	<b>LS</b>
LC8	950 Adventure	02-07	<b>LS</b>
	990 Super Duke	04-13	<b>LS</b>
	990 Super Duke		
	R	09-13	<b>LS</b>

<b>MAICO</b>			
	250 Motocross/		
	Enduro	99-01	<b>SI</b>



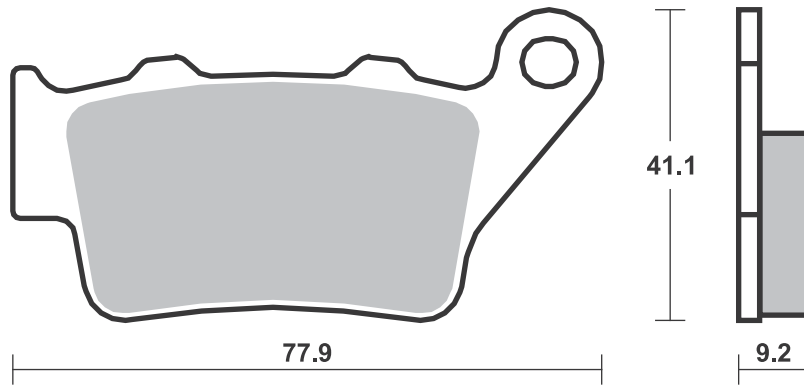
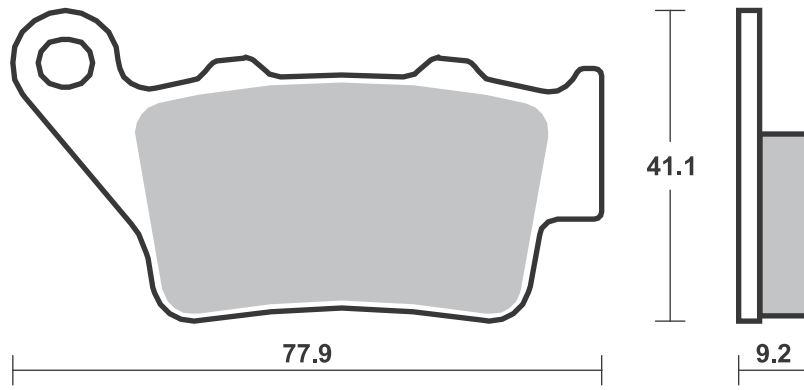

**SBS 675** Recommended compound

<b>MAICO</b>			
500 Motocross/			
Enduro	99	<b>SI</b>	
500 Supermotard	99	<b>HF</b>	

<b>ROYAL ENFIELD</b>			
535 Continental			
GT	14-17	<b>LS</b>	

<b>SWM</b>			
600 Superdual			
GT Pack	18-	<b>LS</b>	
600 Superdual T	18-	<b>LS</b>	
600 Superdual X	18-	<b>LS</b>	
650 Superdual	15-18	<b>LS</b>	

<b>TM</b>			
80 Cross	96-00	<b>RSI</b>	
125	96-00	<b>RSI</b>	
250 E	95-00	<b>RSI</b>	
250 F Enduro	00	<b>SI</b>	
300	98-00	<b>RSI</b>	
320	96-97	<b>RSI</b>	
400 F	00	<b>RSI</b>	

<b>TRIUMPH</b>			
660 Street			
Triple S A2	17-18	<b>LS</b>	
675 Daytona R			
Triple	13-18	<b>LS</b>	
675 Daytona			
Triple	13-18	<b>LS</b>	
675 Street Triple	13-17	<b>LS</b>	
675 Street Triple			
R	13-17	<b>LS</b>	
675 Street Triple			
RX	15-16	<b>LS</b>	
765 Street Triple			
R	17-18	<b>LS</b>	
765 Street Triple			
R Low	17-18	<b>LS</b>	
765 Street Triple			
RS	17-18	<b>LS</b>	



<b>TRIUMPH</b>			
765 Street Triple			
S	17-18	<b>LS</b>	

<b>VERTEMATI</b>			
C	500 Cross	02-04	<b>RSI</b>
E	501 Enduro	02-04	<b>SI</b>
S	501 Supermotard	02-04	<b>HF</b>

<b>VICTORY</b>			
1200 Octane	17	<b>H.LS</b>	

<b>VOR</b>			
400 Cross	00-01	<b>RSI</b>	
400 Enduro	00-01	<b>SI</b>	
EN	400	02-03	<b>SI</b>
MX	400	02	<b>RSI</b>
SM	400	02	<b>RSI</b>
EN	450	02-04	<b>SI</b>
MX	450	02-04	<b>RSI</b>
SM	450	02-04	<b>RSI</b>
500 492 Enduro	99	<b>SI</b>	
500 492 Super			
Motard	00-01	<b>HF</b>	
500 495 Cross	99	<b>RSI</b>	
EN	530	02-04	<b>SI</b>
MX	530	02-04	<b>RSI</b>
SM	530	02-04	<b>RSI</b>

<b>YAMAHA</b>			
WR	125 R, XY	09-16	<b>HF</b>
XT	660 R	04-11	<b>LS</b>
XT	660 X	04-13	<b>LS</b>
XT	660 Z Tenere	08-14	<b>LS</b>
XT	660 Z Tenere		
ABS	11-14	<b>LS</b>	

<b>ZERO</b>			
DS	ZF11.4	14	<b>LS</b>
DS	ZF12.5	15	<b>LS</b>
DS	ZF13.0	16-17	<b>LS</b>
DS	ZF8.5	14	<b>LS</b>
DS	ZF9.4	15	<b>LS</b>



<b>ZERO</b>			
DS	ZF9.8	16-17	<b>LS</b>
DSR	ZF13.0	16-17	<b>LS</b>
FX	ZF2.8	14-15	<b>LS</b>
FX	ZF3.3	16-17	<b>LS</b>
FX	ZF5.7	14-15	<b>LS</b>
FX	ZF6.5	16-17	<b>LS</b>
FXS	ZF3.3	16-17	<b>LS</b>
FXS	ZF6.5	16-17	<b>LS</b>
S	ZF11.4	14	<b>LS</b>
S	ZF12.5	15	<b>LS</b>
S	ZF13.0	16-17	<b>LS</b>
S	ZF8.5	14	<b>LS</b>
S	ZF9.4	15	<b>LS</b>
S	ZF9.8	16-17	<b>LS</b>
SR	ZF11.4	14	<b>LS</b>
SR	ZF12.5	15	<b>LS</b>
SR	ZF13.0	16-17	<b>LS</b>

**SBS 676** Recommended compound

<b>BRAKING</b>			
Front Harley Davidson			

<b>BUELL</b>			
M2	1200 Cyclone	98-02	<b>HS</b>
S1	1200 Lightning	98-02	<b>HS</b>
S1	1200 Whitelighting	98-02	<b>HS</b>
S3	1200 Thunderbolt	98-02	<b>HS</b>
X1	1200 Lightning	01-02	<b>HS</b>

<b>HHI</b>			
6 Piston Caliper			

<b>KAWASAKI</b>			
ZX-7RR	750 Ninja	96-02	<b>HS</b>



<b>MV AGUSTA</b>			
750 Brutale,			
Brutale S	01-05	<b>HS</b>	
750 F4 SPR	01-03	<b>HS</b>	
750 F4/F4S	99-02	<b>HS</b>	
910 Brutale	06-08	<b>HS</b>	
910 Brutale R	06-08	<b>HS</b>	
910 Brutale S	06-08	<b>HS</b>	
1000 F4 Mamba	04-06	<b>HS</b>	
1000 F4 Tamburini	04-06	<b>HS</b>	
1000 F4S	04-06	<b>HS</b>	

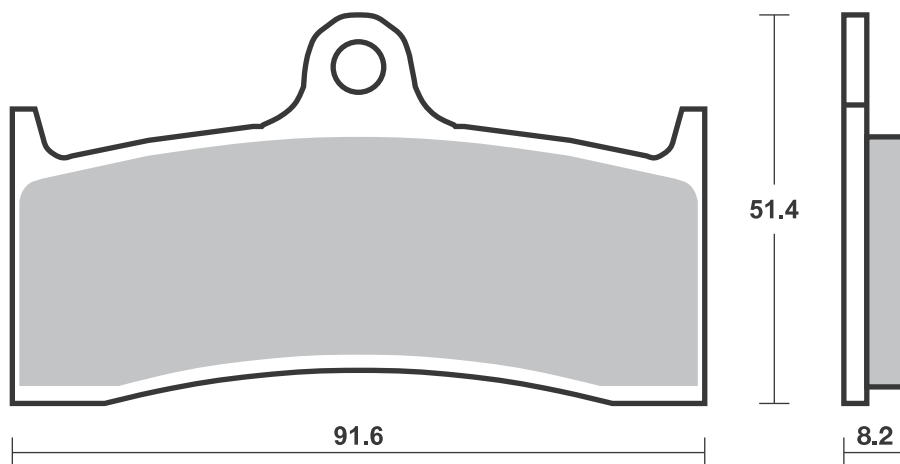
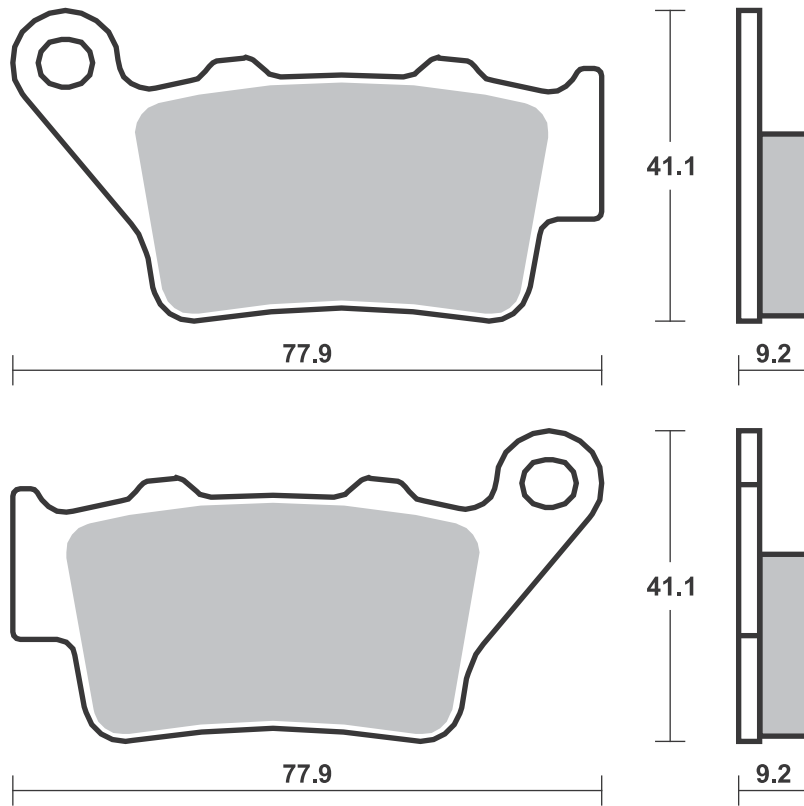



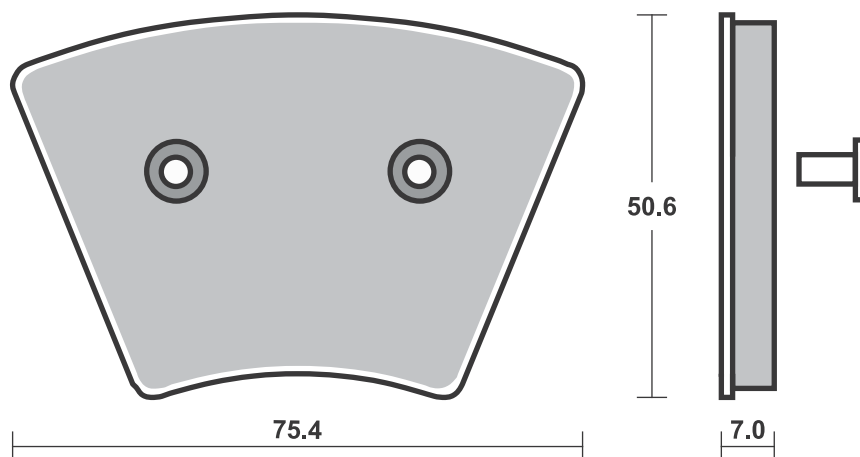
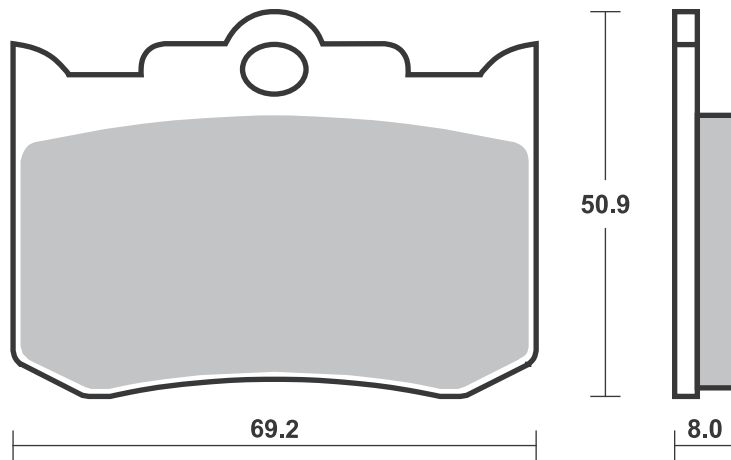
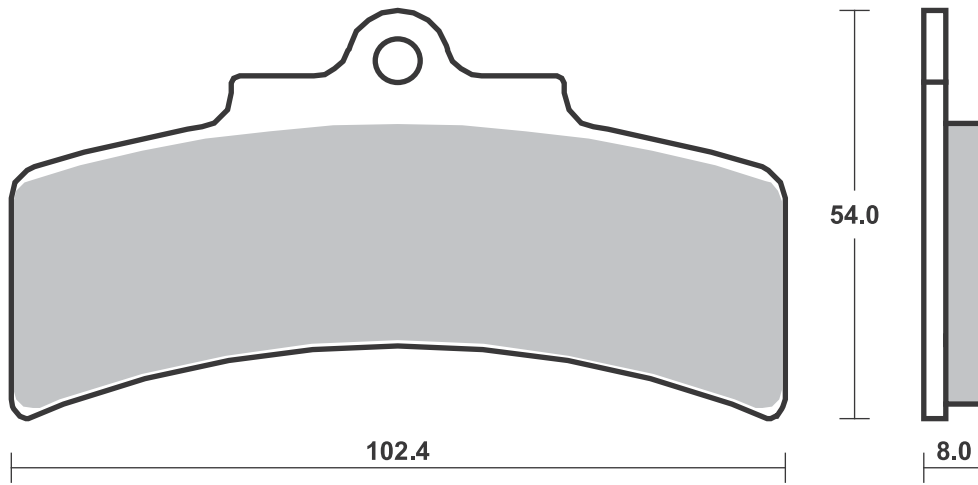



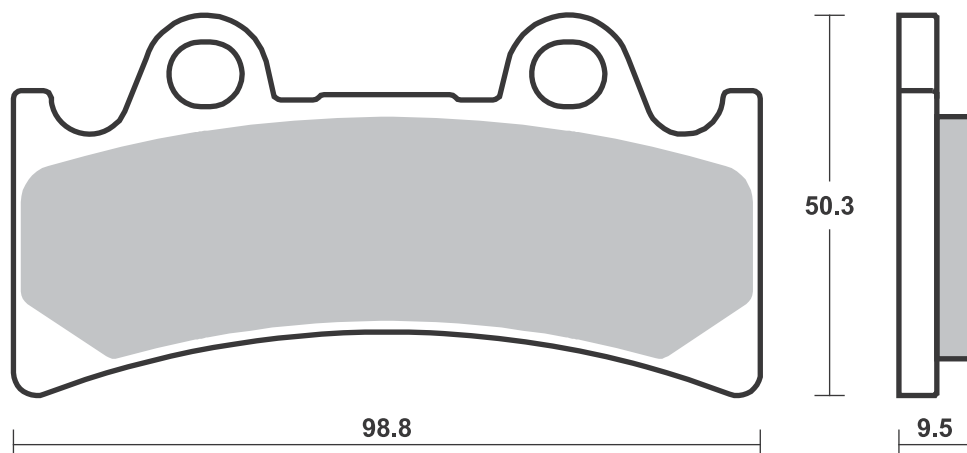
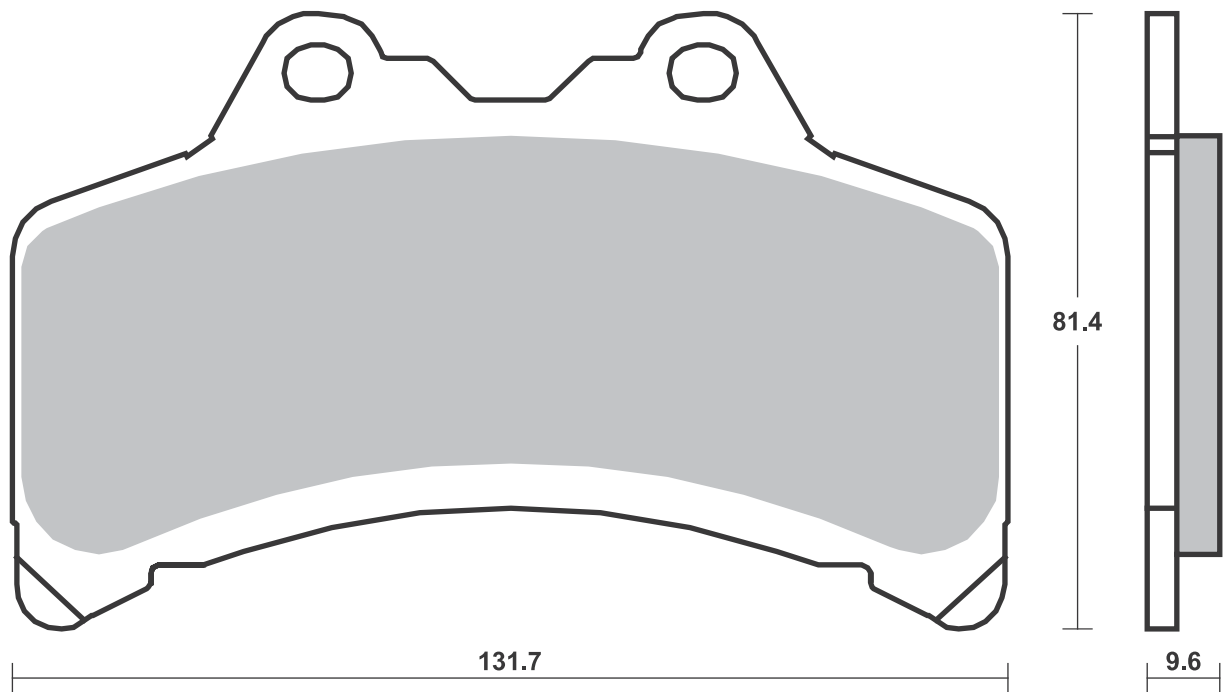
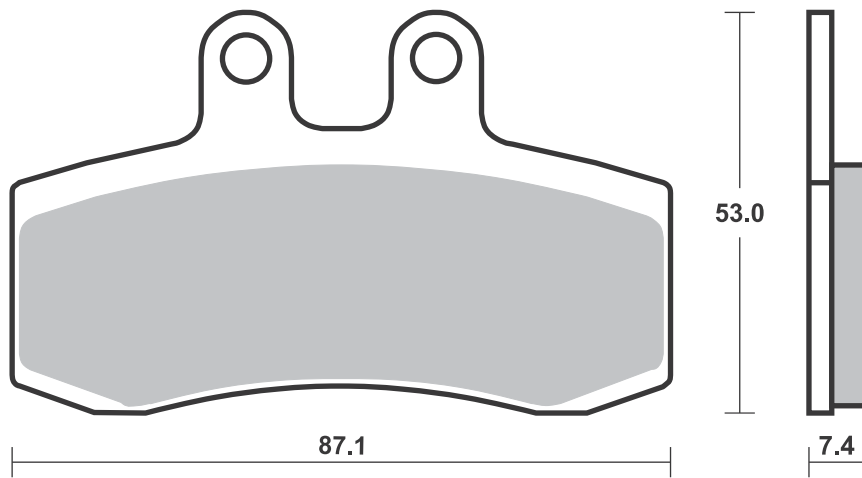





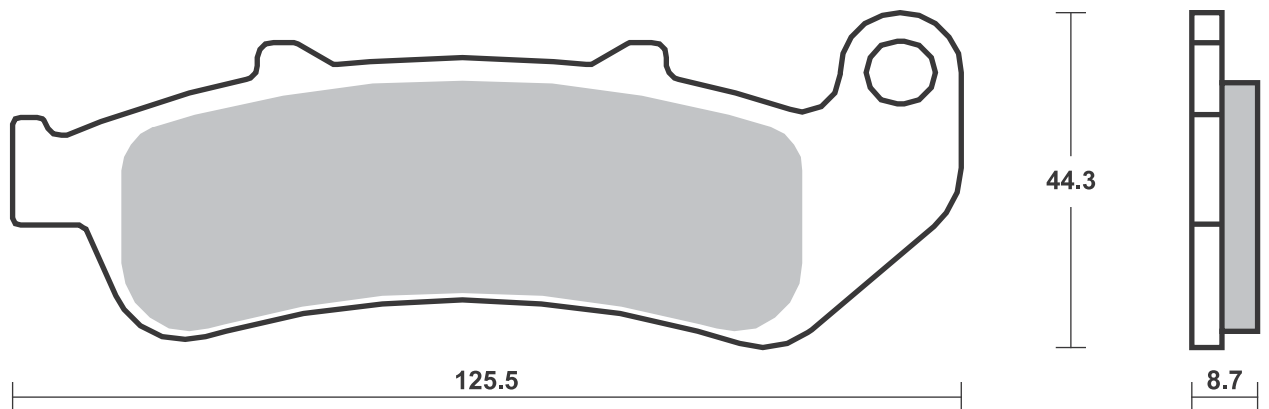
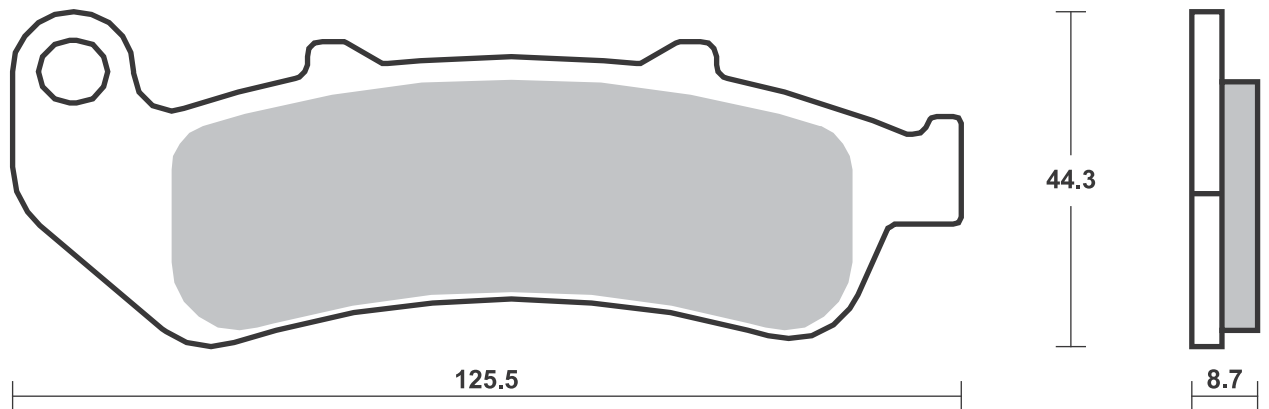
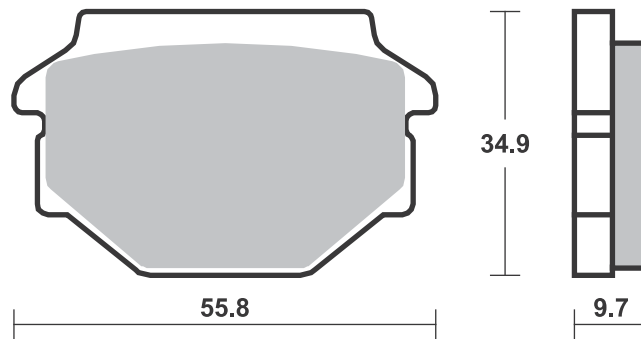
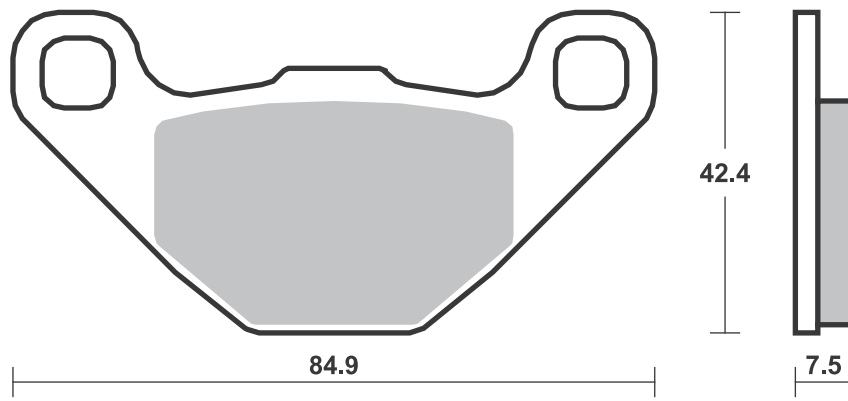

**SBS 686** Recommended compound



**JAYBRAKE**

4 Piston Caliper A4 P/L		
4 Piston J-Four Caliper		

**KAWASAKI**

ZX-6R 600 Ninja	98-01	<b>HS</b>
ZX-6R 636 Ninja	02	<b>HS</b>
ZX-7R 750 Ninja	96-03	<b>HS</b>
ZX-9R 900 Ninja	96-01	<b>HS</b>
ZRX 1100	96-00	<b>HS</b>
ZRX 1200	01-04	<b>HS</b>
ZRX 1200 R	01-08	<b>HS</b>
ZRX 1200 S	01-07	<b>HS</b>
ZX-12R 1200 Ninja	00-03	<b>HS</b>
VN 1500 Mean Streak	02-03	<b>HS</b>
VN 1600 Mean Streak	04	<b>HS</b>

**SUZUKI**

GSF 1200 S Bandit	01-05	<b>HS</b>
GSX-R 1300 Hayabusa	99-07	<b>HS</b>
GSX 1400	02-07	<b>HS</b>
VZ 1600 Marauder	04	<b>HS</b>

**SUZUKI**

GSX-R 750	94-99	<b>HS</b>
GSX-R 1000	01-02	<b>HS</b>
TL 1000 RW	98-02	<b>HS</b>
GSX-R 1100	93-97	<b>HS</b>
GSF 1200 Bandit	01-05	<b>HS</b>

**SBS 687** Recommended compound



**KAWASAKI**

400 Ninja R		
Left/Rear	11	<b>LS</b>
ZX-6R 600 (Ninja ZX6)	93-97	<b>LS</b>
ZX-6R 600 (Ninja ZX6R)	95-97	<b>LS</b>
ZX-6R 600 Ninja	98-01	<b>LS</b>
ZX-6R 600 Ninja	07-12	<b>LS</b>
ZX-6RR 600 Ninja	03-06	<b>LS</b>
ZX-6R 636 Ninja	02	<b>LS</b>
ZX-6R 636 Ninja	03-06	<b>LS</b>
650 R Ninja		
Left/Rear	06-08	<b>LS</b>
KLE 650 Versys		
Left/Rear	07-14	<b>LS</b>
Z 750 Left/Rear	04-06	<b>LS</b>
Z 750 S Left/Rear	05-06	<b>LS</b>
ZX-9R 900 Ninja	94-03	<b>LS</b>
Z 1000	10-16	<b>LS</b>
Z 1000 ABS	15-18	<b>LS</b>
Z 1000	03-06	<b>LS</b>
Z 1000 Ninja	14-16	<b>LS</b>
Z 1000 SE	14-16	<b>LS</b>
Z 1000 SX	11-13	<b>LS</b>
ZX-10R 1000 Ninja	04-10	<b>LS</b>
GPZ 1100 (ZX 1100)		
Left/Rear	95-99	<b>LS</b>

Brake Pad 1:1 Drawings, Compounds, Fitments

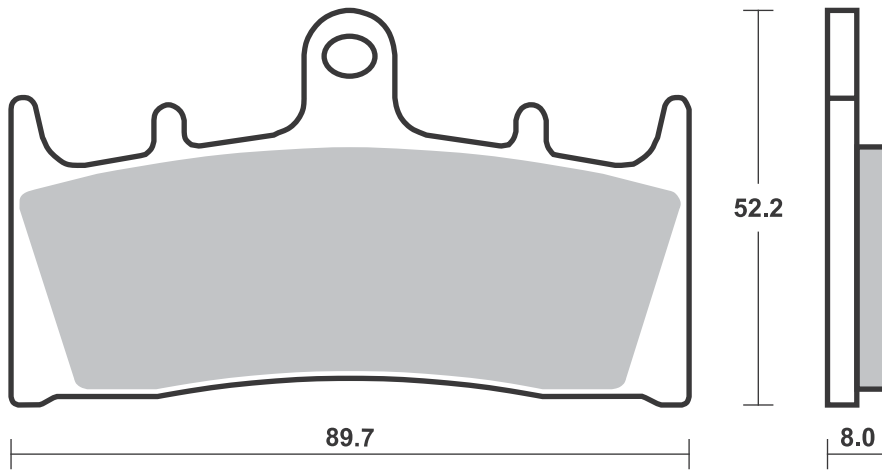

HF / HS - Th. 8.0  
RS / DC - Th. 9.5

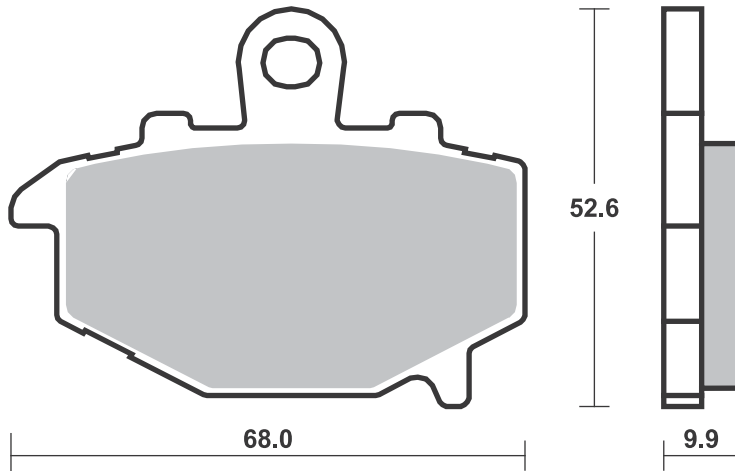
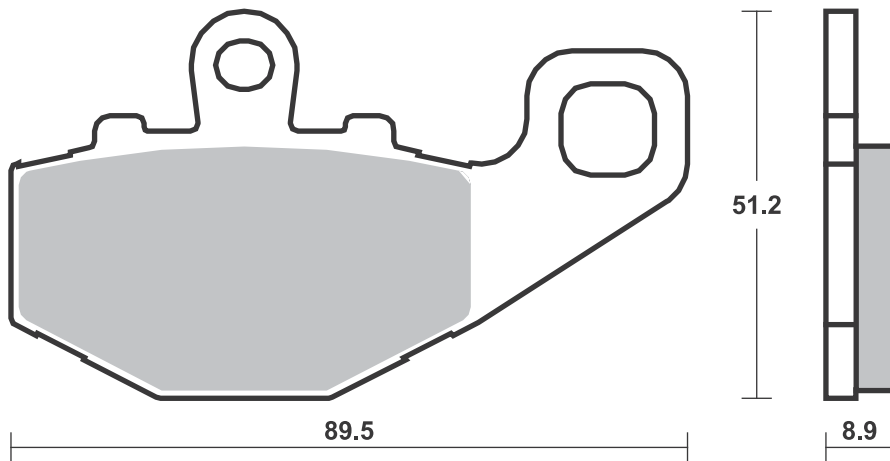



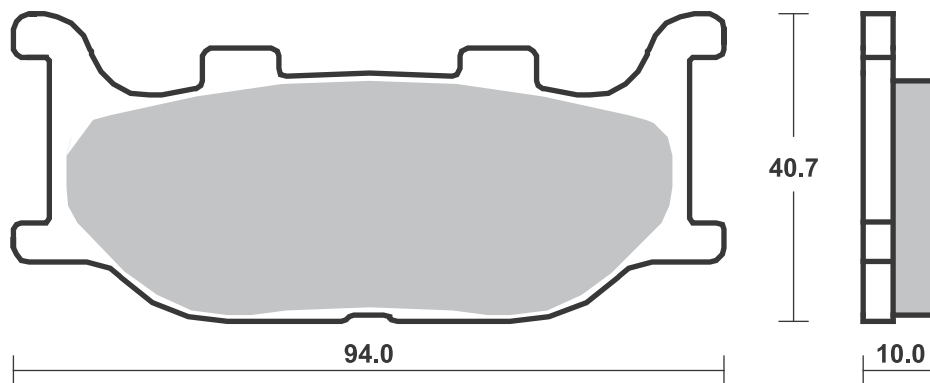
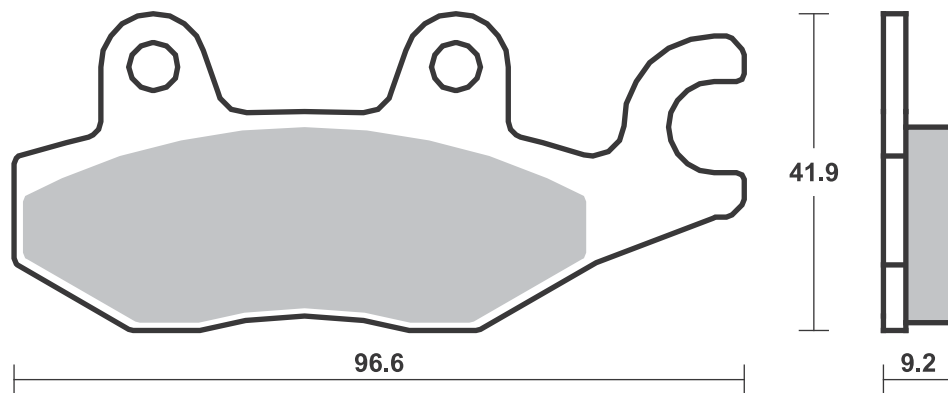
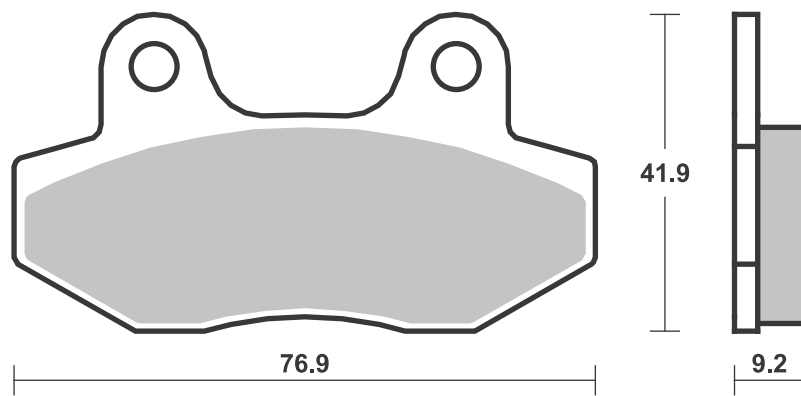

**SBS 692** Recommended compound

<b>APRILIA</b>			
	650 Pegaso	95-00	<b>HF</b>
<b>BUELL</b>			
	all models	94-97	<b>HF</b>
RS	1200	12	<b>HF</b>
<b>CAGIVA</b>			
	125 Cross	86	<b>SI</b>
WMX	125	89-90	<b>SI</b>
WMX	250	89-90	<b>SI</b>
<b>HUSQVARNA</b>			
CR/WR	125	91	<b>SI</b>
WR	240	91	<b>SI</b>
CR	250	91	<b>SI</b>
WR	260	90-93	<b>SI</b>
TC	610 Cross	91	<b>SI</b>
TE	610	91-95	<b>SI</b>
<b>KTM</b>			
MX	125	89-93	<b>SI</b>
MX	250	89-93	<b>SI</b>
MX	500	89-93	<b>SI</b>

**SBS 694** Recommended compound

<b>APRILIA</b>			
MXV	450	09-13	<b>RSI</b>
RXV	450	06-13	<b>SI</b>
RXV	550	06-13	<b>SI</b>
<b>BETA</b>			
RR	125	18-	<b>SI</b>
RR	250	05-09	<b>SI</b>
	300 Crosstrainer	15	<b>SI</b>
RR	300	13-18	<b>SI</b>
RR	350 Efi	15	<b>SI</b>
RR	350 Efi Racing	15	<b>SI</b>
RR	350 Enduro	12-14	<b>SI</b>
RR	390	15-18	<b>SI</b>
RR	400 Enduro	05	<b>SI</b>
RR	430	15-18	<b>SI</b>
RR	430 Racing	15-18	<b>SI</b>
RR	450 Cross C		
	ountry	12	<b>SI</b>
RR	450 Enduro	05-07	<b>SI</b>
RR	480	15-18	<b>SI</b>
RR	480 Racing	15-18	<b>SI</b>
RR	498 Enduro	12-14	<b>SI</b>
RR	525 Enduro	05-13	<b>SI</b>
<b>BIMOTA</b>			
BBX	300 Enduro	12	<b>SI</b>

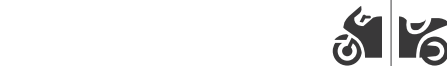

<b>BIMOTA</b>			
BBX	508 Enduro	12	<b>SI</b>
<b>BRACING</b>			
	Front cross		
<b>CANNONDALE</b>			
MX	400	00-03	<b>RSI</b>
C	440 R	03	<b>RSI</b>
E	440 , A, R	03	<b>RSI</b>
X	440	03	<b>RSI</b>
<b>CPI</b>			
	125 Sahel	02	<b>HF</b>
<b>GAS GAS</b>			
	125 Enducross	93	<b>SI</b>
EC	125	00-06	<b>SI</b>
MC	125	03-13	<b>RSI</b>
EC	200	00-09	<b>SI</b>
EC	200	17	<b>SI</b>
EC	200 Hobby	07-16	<b>SI</b>
XC	200	18-	<b>SI</b>
EC	250	00-18	<b>SI</b>
EC	250 Enduro		
	GP 18	18-	<b>SI</b>
EC	250 fse	02-11	<b>SI</b>



<b>GAS GAS</b>			
MC	250	00-13	<b>SI</b>
XC	250	17	<b>SI</b>
EC	300	00-18	<b>SI</b>
EC	300 Enduro		
	GP 18	18-	<b>SI</b>
XC	300	18-	<b>SI</b>
	400 Pampera	06-09	<b>SI</b>
EC	400 fse	02	<b>SI</b>
EC	450 fse	03-15	<b>SI</b>
EC	450 FSR	07-16	<b>SI</b>
EC	515 fsr	08-16	<b>SI</b>
<b>HONDA</b>			
CR	125 R	95-07	<b>RSI</b>
CRE	125	02-07	<b>SI</b>
CRF	125 F	14-18	<b>SI</b>
XLR	125 R	98-01	<b>HF</b>
XR	125 L	03-07	<b>HF</b>
CRF	150 F	03-06	<b>SI</b>
CTX	200	04-06	<b>SI</b>
CRF	230	04-09	<b>SI</b>
CRF	230 L	08-10	<b>SI</b>
CRF	230 M	09-12	<b>SI</b>
SL	230	97-01	<b>HF</b>
CR	250 R	95-07	<b>RSI</b>
CRE	250	02-07	<b>SI</b>

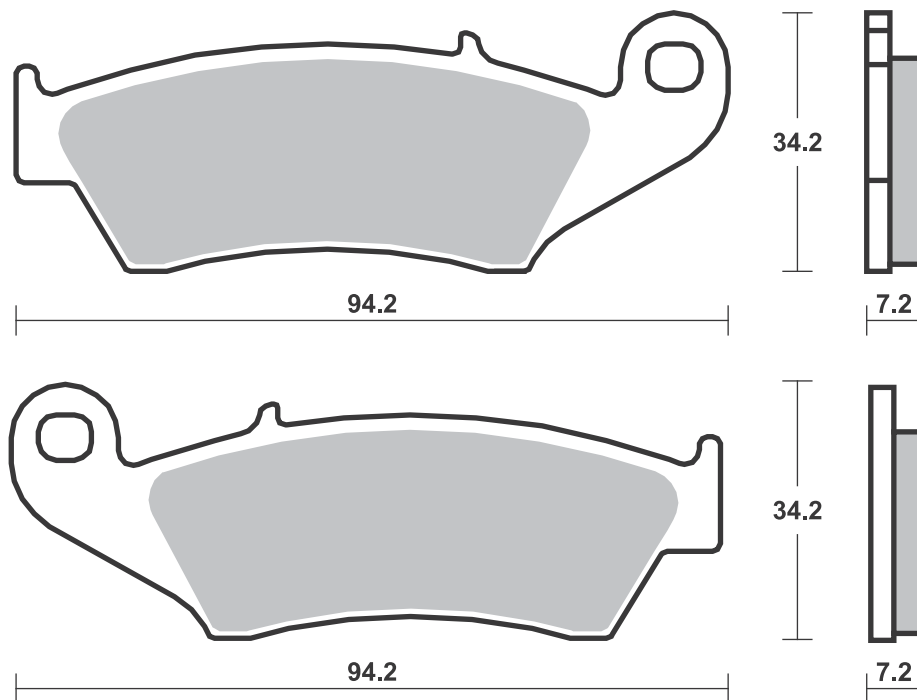
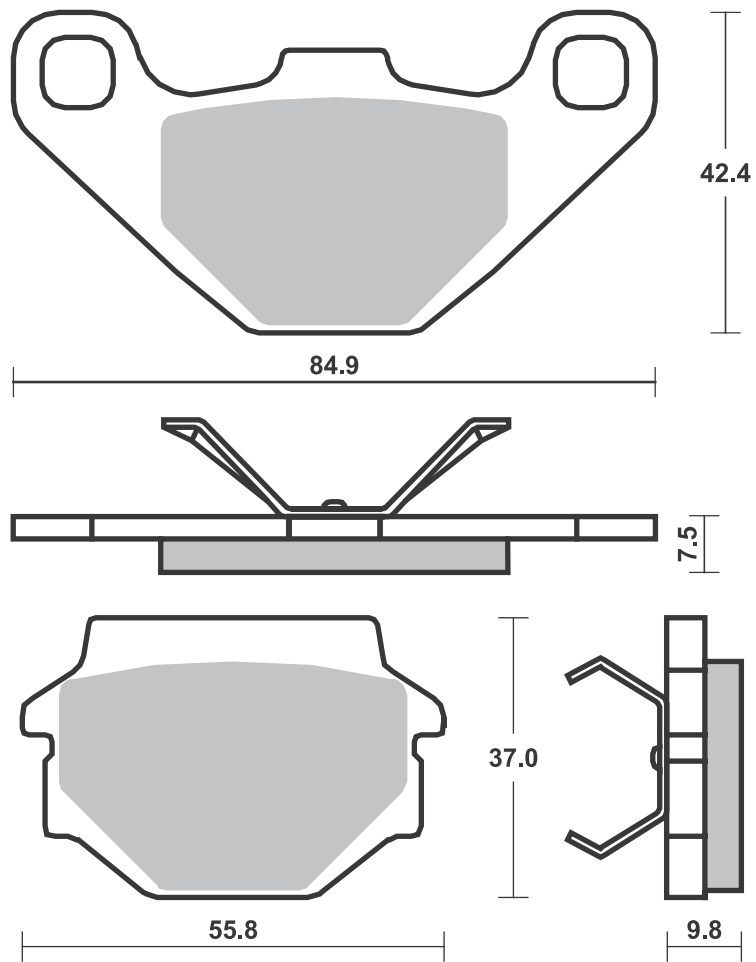





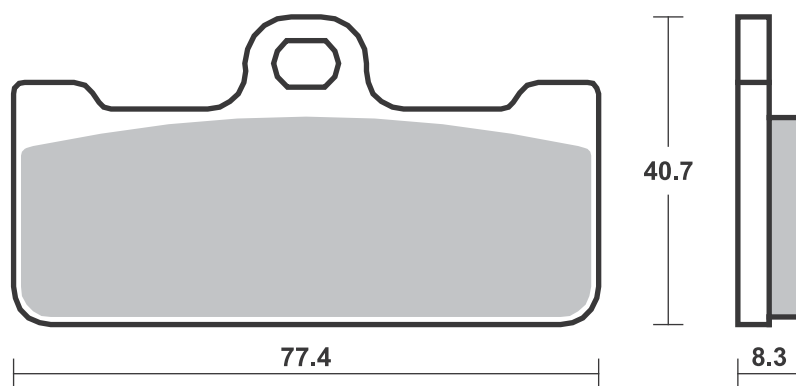
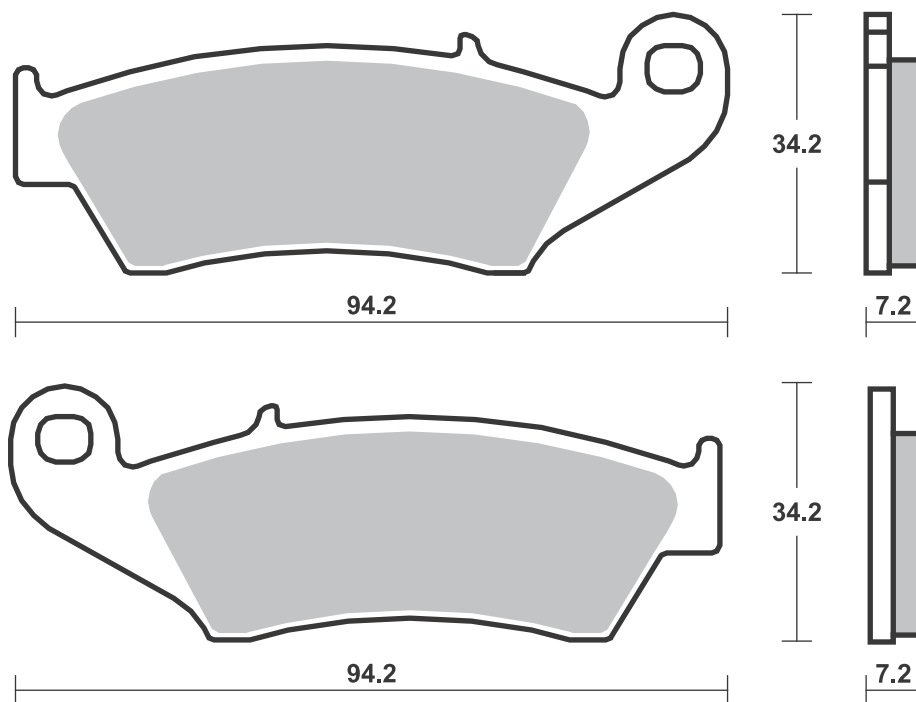



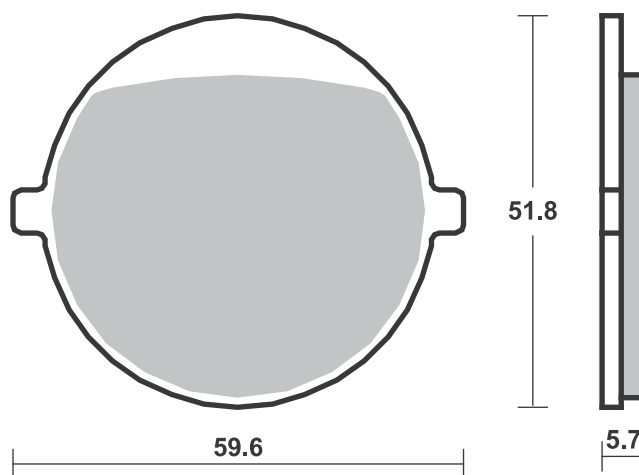
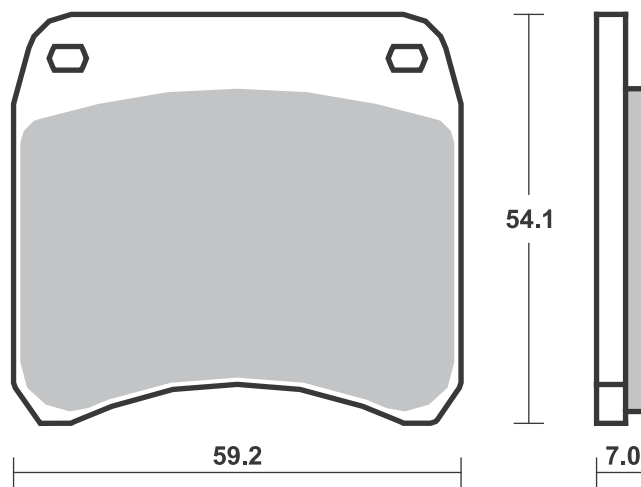



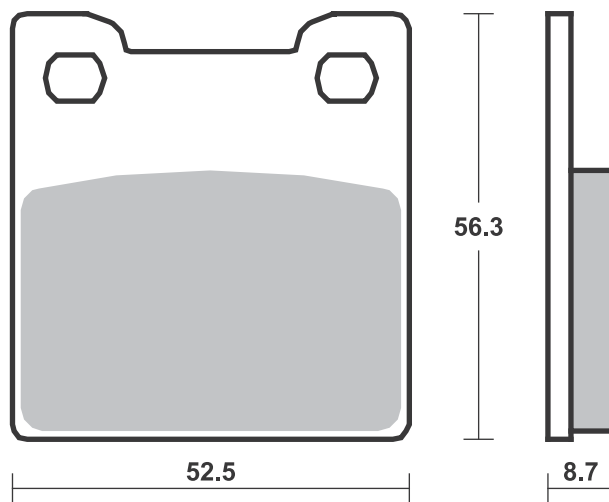
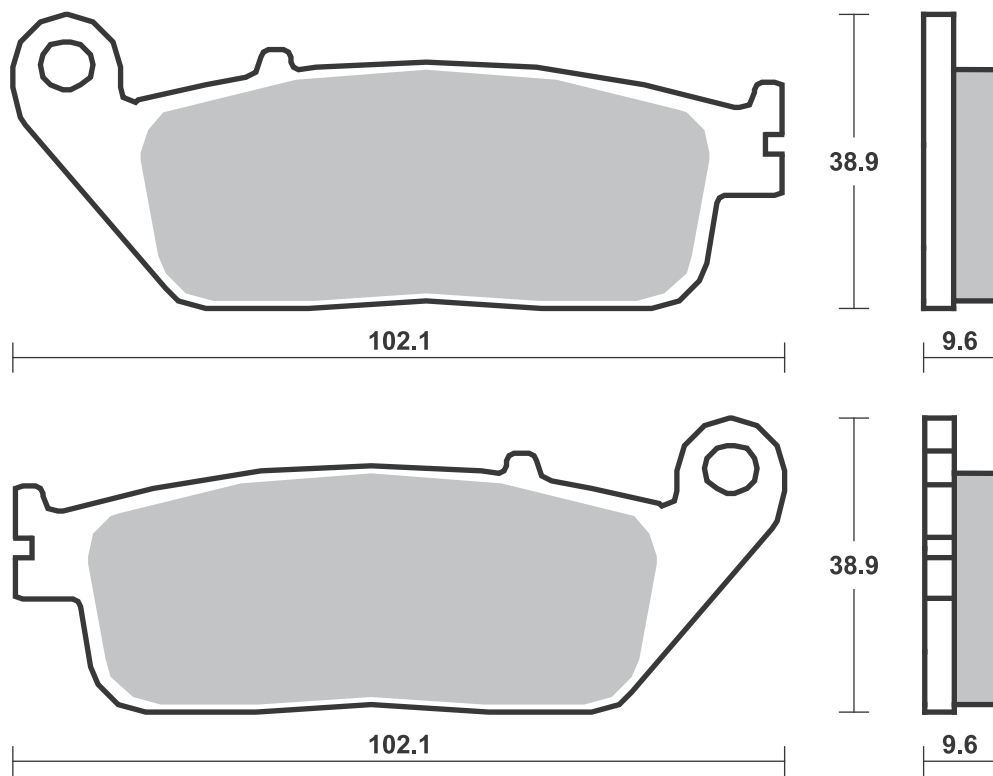



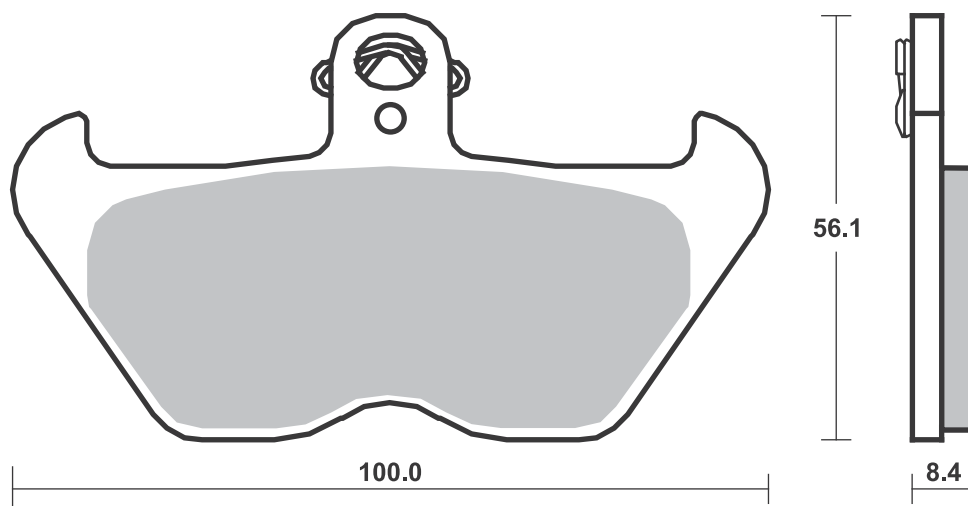
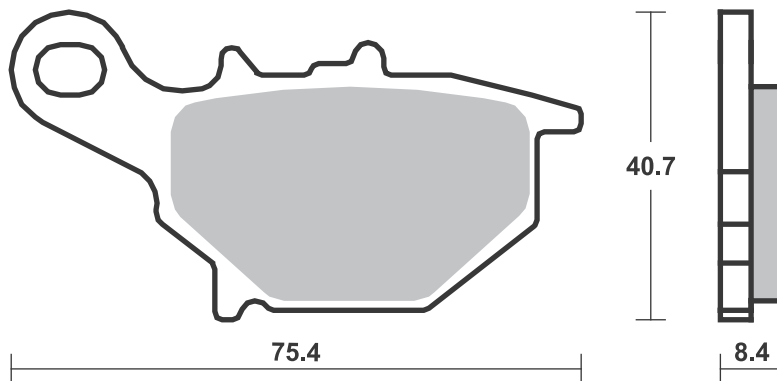
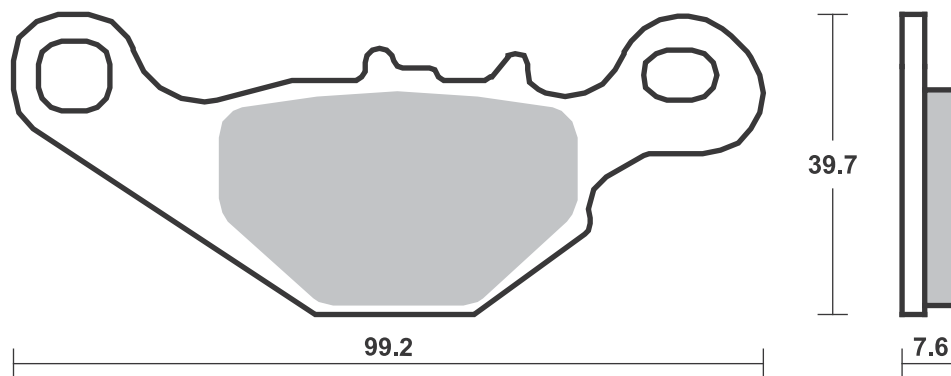

**SBS 704** Recommended compound

<b>KAWASAKI</b>			
400 Ninja R Right	11	<b>HS</b>	
650 R Ninja Right	06-08	<b>HS</b>	
KLE 650 Versys Right	07-14	<b>HS</b>	
W 650	99-05	<b>HF</b>	
Z 750 Right	04-06	<b>HS</b>	
Z 750 S Right	05-06	<b>HS</b>	
ZR-7S 750 Left/Rear	01-04		<b>LS</b>
ZR-7S 750 Right	01-04	<b>HS</b>	
VN 800 Vulcan			
Drifter	99-03		<b>LS</b>
W 800	11-16	<b>HS</b>	
KLV 1000 Right	04-07	<b>HS</b>	
KZ 1000 Police Right	02-03	<b>HS</b>	
GPZ 1100 (ZX 1100)			
Right	95-99	<b>HS</b>	
VN 1500 Vulcan			
Drifter	99-02		<b>LS</b>
VN 1500 Vulcan			
Nomad			
Fi Right	00-04	<b>HS</b>	
VN 1500 Vulcan			
Nomad Right	98-01	<b>HS</b>	
VN 1600 Nomad Right	05-06	<b>HS</b>	
VN 1600 Vulcan			
Classic Right	03-08	<b>HS</b>	
VN 1700 Voyager			
Vaquero			
Right	09-14	<b>HS</b>	



<b>KAWASAKI</b>			
VN 1700 Vulcan			
Classic			
Right	09-14	<b>HS</b>	
VN 1700 Vulcan			
Nomad			
Right	09-16	<b>HS</b>	
<b>SUZUKI</b>			
RV 125 VanVan	03-18	<b>HF</b>	
RV 200 VanVan	16-18	<b>HF</b>	
GS 500	96-08	<b>HS</b>	
GS 500 F	04-08	<b>HS</b>	
GSF 600 Bandit /			
S Bandit			
Right	00-04	<b>HS</b>	
GSX 600 FW Right	98-04	<b>HS</b>	
DL 650 V-Strom			
Right	04-13	<b>HS</b>	
DL 650 V-Strom			
Right	17-18	<b>HS</b>	
DL 650 V-Strom XT			
Right	15-18	<b>HS</b>	
GSF 650 Bandit /			
S Bandit			
Right	05	<b>HS</b>	
GSF 650 Bandit /			
S Bandit			
Right ABS	06	<b>HS</b>	



<b>SUZUKI</b>			
SFV 650 Gladius			
Right	09-16	<b>HS</b>	
SV 650 ,S Right	99-12	<b>HS</b>	
SV 650 Right	16-18	<b>HS</b>	
SV 650 X Right	18-	<b>HS</b>	
GSR 750 Right	11-14	<b>HS</b>	
GSX 750 FW Right	98-02	<b>HS</b>	
GSX 750 Right	98-08	<b>HS</b>	
GSX-S 750 Right	15-16	<b>HS</b>	
GSX-S 750 Z Right	15-16	<b>HS</b>	
C50 800 Boulevard	05-18	<b>HS</b>	
M50 800 Boulevard	05-18	<b>HS</b>	
VL 800 Intruder LC			
Volusia	01-04	<b>HS</b>	
VZ 800 Marauder	97-04	<b>HS</b>	
DL 1000 V-Strom			
Right	02-13	<b>HS</b>	
GSX 1100 G Right	96-98	<b>HS</b>	
C90 1500 Boulevard			
Right	05-18	<b>HS</b>	
M90 1500 Right	09-18	<b>HS</b>	
VL 1500 Intruder LC			
Right	02	<b>HS</b>	

**SBS 705** Recommended compound

<b>KAWASAKI</b>			
400 Ninja R			
Left/Rear	11	<b>HS</b>	
650 R Ninja			
Left/Rear	06-08	<b>HS</b>	
KLE 650 Versys			
Left/Rear	07-14	<b>HS</b>	
KLR 650	95-04	<b>HS</b>	
Z 750 Left/Rear	04-06	<b>HS</b>	
Z 750 S Left/Rear	05-06	<b>HS</b>	
ZR-7S 750 Left/Rear	01-04	<b>HS</b>	
VN 800 Vulcan			
Classic	96-06	<b>HS</b>	
VN 800 Vulcan			
Drifter	99-03	<b>HS</b>	
VN 900 Vulcan			
Classic	06-16	<b>HS</b>	
VN 900 Vulcan			
Classic SE	11-16	<b>HS</b>	
VN 900 Vulcan			
Custom	07-16	<b>HS</b>	
KLV 1000 Left/Rear	04-07	<b>HS</b>	
KZ 1000 Police			
Left/Rear	02-03	<b>HS</b>	
GPZ 1100 (ZX 1100)			
Left/Rear	95-99	<b>HS</b>	
VN 1500 Vulcan			
Classic	97-99	<b>HS</b>	
VN 1500 Vulcan			
Classic Fi	00-04	<b>HS</b>	
VN 1500 Vulcan			
Drifter	99-02	<b>HS</b>	



<b>KAWASAKI</b>			
VN 1500 Vulcan			
Nomad Fi			
Left/Rear	00-04	<b>HS</b>	
VN 1500 Vulcan			
Nomad			
Left/Rear	98-01	<b>HS</b>	
VN 1600 Nomad			
Left/Rear	05	<b>HS</b>	
VN 1600 Vulcan			
Classic			
Left/Rear	03-08	<b>HS</b>	
VN 1700 Voyager			
Vaquero			
Left/Rear	09-14	<b>HS</b>	
VN 1700 Vulcan			
Classic			
Left/Rear	09-14	<b>HS</b>	
VN 1700 Vulcan			
Nomad			
Left/Rear	09-16	<b>HS</b>	
<b>SUZUKI</b>			
TU 250 X	09-18	<b>HF</b>	
GSF 600 Bandit /			
S Bandit			
Left/Rear	00-04	<b>HS</b>	
GSX 600 FW Left	98-04	<b>HS</b>	
DL 650 V-Strom			
Left/Rear	04-13	<b>HS</b>	
DL 650 V-Strom			
Left/Rear	17-18	<b>HS</b>	



<b>SUZUKI</b>			
DL 650 V-Strom XT			
Left/Rear	15-18	<b>HS</b>	
GSF 650 Bandit /			
S Bandit			
Left/Rear	05	<b>HS</b>	
GSF 650 Bandit /			
S Bandit			
Left/Rear			
ABS	06	<b>HS</b>	
SFV 650 Gladius			
Left/Rear	09-16	<b>HS</b>	
SV 650 ,S ABS	07-10	<b>HS</b>	
SV 650 ,S ABS	15-18	<b>HS</b>	
SV 650 ,S Left/Rear	99-12	<b>HS</b>	
SV 650 Left/Rear	16-18	<b>HS</b>	
SV 650 X Left/Rear	18-	<b>HS</b>	
GSR 750 Left/Rear	11-16	<b>HS</b>	
GSX 750 FW Left/Rear	98-02	<b>HS</b>	
GSX 750 Left/Rear	98-08	<b>HS</b>	
GSX-S 750 Left/Rear	15-16	<b>HS</b>	
GSX-S 750 Z Left/Rear	15-16	<b>HS</b>	
DL 1000 V-Strom			
Left/Rear	02-13	<b>HS</b>	
GSX 1100 G Left/Rear	96-98	<b>HS</b>	
C90 1500 Boulevard			
Left/Rear	05-18	<b>HS</b>	
M90 1500 Left/Rear	09-18	<b>HS</b>	
VL 1500 Intruder LC			
Left/Rear	02	<b>HS</b>	



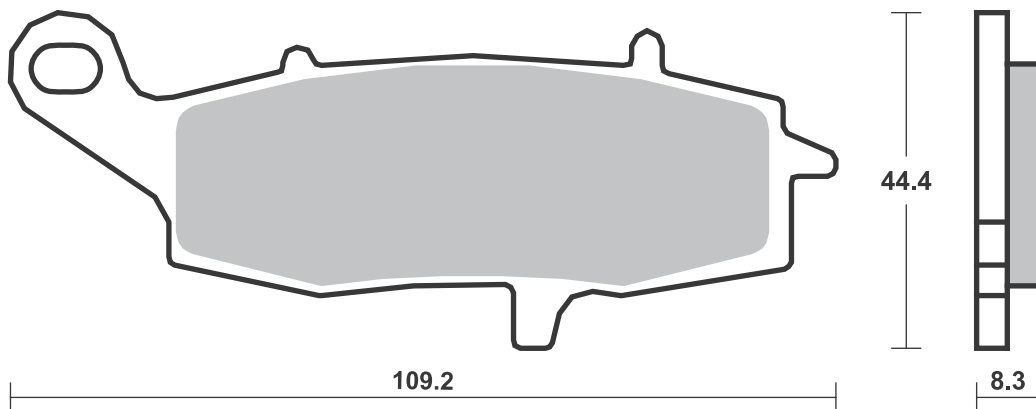
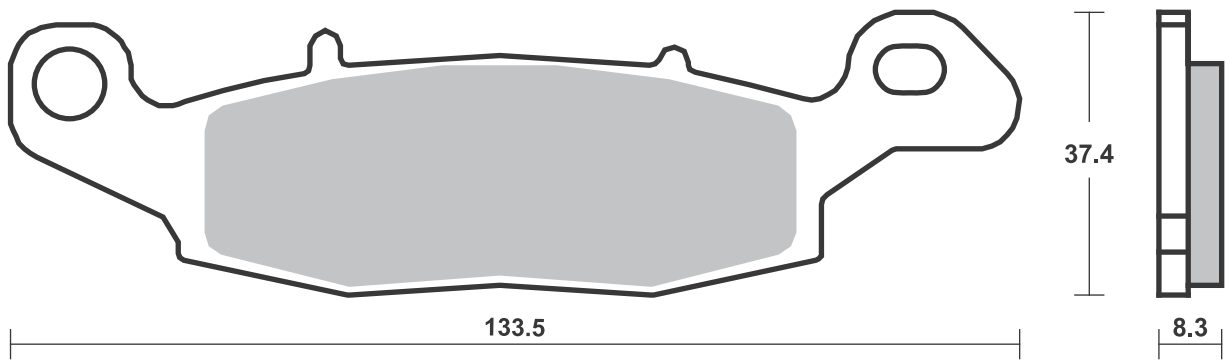
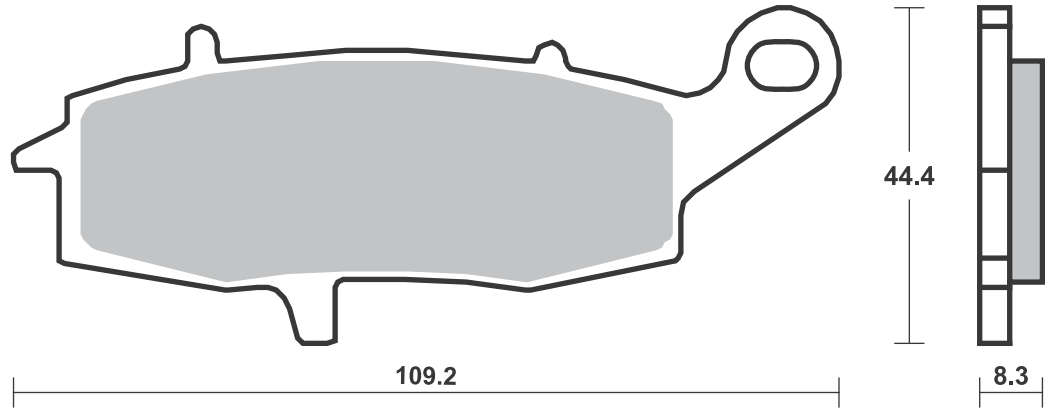
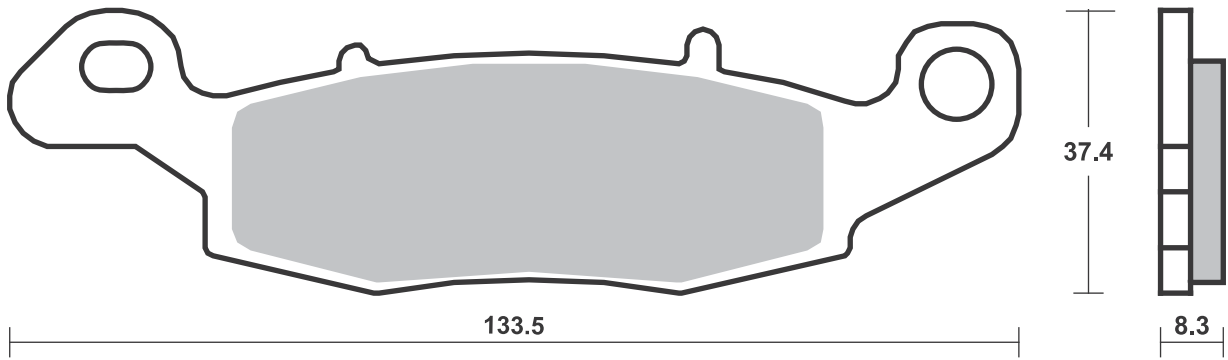



<b>APRILIA</b>			
RS	250	97-02	HF
RS	250 Pista	04	HF
	650 Pegaso		
	Strada	05-09	HS
	750 Dorsoduro		
	Factory	12-13	HS
SMV	750 Dorsoduro	08	HS
	1000 Blue Marlin	02	HS
RST	1000 Futura	01-03	HS
RSV	1000 Falco SL, R	00-04	HS
RSV	1000 Mille	97-01	HS
RSV	1000 Mille R	00	HS
RSV	1000 Mille SP	00	HS
RSV	1000 Tuono		
	Fighter	03-05	HS
RSV	1000 Tuono R,		
ABS	04 -	12	HS
RSV	1000 Tuono V4 R	11-13	HS
	1200 Dorsoduro,		
	ABS	11-14	HS
<b>BENELLI</b>			
	500 Leoncino	16-17	HS
TRK	502	16-17	HS
BN	600	12-13	HS
	756 Cue	10-12	HS
	899 Trek	07-12	HS
TnT	899	07-15	HS
	900 Tornado 3	00-06	HS
TnT	1100	04	HS
TnT	1130	05-14	HS
TnT	1130 Trek	06-12	SP
TnT	1130 Trek		
	Amazonas	07-15	SP
<b>BIMOTA</b>			
DB4	900	99-00	HS
SB8	1000 R	98-00	HS
SB8K	1000	06	HS
<b>BMW</b>			
G	650 Xmoto	06-07	HS
F	800 GT	13-18	HS
F	800 R	09-14	HS
F	800 S	06-10	HS
F	800 ST	06-12	HS
F	800 ST Touring	11-12	HS
R	1200 Nine-T Pure	17-18	HS
R	1200 Nine-T Racer	17-18	HS
R	1200 Nine-T		
	Scrambler	16-18	HS
R	1200 Nine-T		
	Urban GS	17-18	HS
<b>BRACING</b>			
Street, Supermotard			
<b>BRAMMO</b>			
	Empulse	14-16	HS
<b>BREMBO RACING CALIPERS</b>			
100 mm Motard Radial			
XA78910, P4 30/34			
100 mm Radial 220A16810,			
P4 30/34			
100 mm Radial 220A80310,			
P4 30/34			

<b>BREMBO RACING CALIPERS</b>			
108 mm Motard Radial			
XA69510, P4 30/34			
108 mm Radial 220A01610,			
P4 30/34			
108 mm Radial 220A80210,			
P4 30/34			
Goldline two pin 20.6800,			
road			
Radial 220A16820,			
P4 30/34			
<b>CAGIVA</b>			
	650 Raptor	01-08	HS
	650 V-Raptor	01-08	HS
	1000 Raptor	00-08	HS
	1000 V-Raptor	00-08	HS
	1000 Xtra Raptor	02-06	HS
<b>DUCATI</b>			
	400 Monster		
	(Japan)	01-06	HS
	600 Monster	00-01	HS
	620 Monster		
	Dark i.e.	02-06	HS
	620 Monster i.e.,		
	s i.e.	02-06	HS
	620 Multistrada		
	Dark	05-06	HS
	620 Sport	03-06	HS
	696 Monster	08-12	HS
	748 , S	99-02	HS
	748 R	00	HS
	748 SPS	98-99	HS
	750 Monster	00-01	HS
	750 Monster i.e.	02	HS
	750 Sport	00-02	HS
	750 Super Sport	00-02	HS
	795 Monster	12	HS
	796 Hypermotard		
	ABS	10-12	HS
	796 Monster	11-14	HS
	796 Monster ABS	11-14	HS
	800 Monster		
	Dark i.e., s i.e.	03-07	HS
	800 Monster i.e.,		
	s i.e.	03-07	HS
	800 Sport	03-06	HS
	800 Supersport	03-06	HS
	848	08-10	HS
	848 Streetfighter	12-15	HS
	900 Monster	00-01	HS
	900 Monster i.e.	02	HS
	900 Super Sport	98-02	HS
MH	900	00-01	HS
	916 Monster S4	01-03	HS
	916 Sport		
	Touring 4	99-01	HS
	916 SPS	97-98	HS
	944 Sport Touring	98-03	HS
	944 ST2	97-03	HS
	992 ST3	04-07	HS
	992 ST3s ABS	06-07	HS
	996 , SPS	99-01	HS
	996 Monster S4R	04-06	HS
	996 ST4s	02-06	HS
	996 ST4s ABS	03-06	HS
	998 , S	02	HS

<b>DUCATI</b>			
	1000 Monster		
	Dark i.e., s i.e.	03-06	HS
	1000 Monster i.e.,		
	s i.e.	03-06	HS
	1000 Monster S2R	06-07	HS
	1000 Multistrada	07	HS
	1000 Multistrada		
	DS	03-06	HS
	1000 Multistrada S		
	DS	05-06	HS
	1000 Supersport		
	DS	03-06	HS
	1100 Hypermotard		
	EVO	10-13	HS
	1100 Monster	09-13	HS
	1100 Monster ABS	09-10	HS
	1100 Monster EVO	11-13	HS
	1100 Monster EVO		
	ABS	11-13	HS
	1100 Monster S	09-13	HS
	1100 Monster S		
	ABS	09-10	HS
	1100 Multistrada	07-09	HS
	1100 Multistrada S	07-09	HS
	1200 Multistrada	10-14	SP
	1200 Multistrada S		
	GT	12-14	SP
	1200 Multistrada S		
	Pikes Peak	11-14	SP
	1200 Multistrada S		
	Sport	10-14	SP
	1200 Multistrada S		
	Touring	10-14	SP
<b>HUSQVARNA</b>			
	570 Nox	01-03	HF
LT	610	00-02	HF
SM	610 Super		
	Motard, S	98-00	HF
SMR	630	04-08	RS
	701 Svartpilen	18-	HS
	701 Vitpilen	18-	HS
	900 Nuda	12-13	HS
<b>KTM</b>			
SMC	625	05-06	HF
	640 Duke	03-06	HF
LC4	640 Supermoto	04	HF
SMC	660 Supermoto	04-07	HF
	690 Duke ABS	12-18	HS
	1050 Adventure	15-16	SP
	1090 Super		
	Adventure	17-18	SP
	1090 Super		
	Adventure R	17-18	SP
	1190 Adventure	13-16	SP
	1290 Super		
	Adventure	15-18	SP
	1290 Super		
	Adventure R	17-18	SP
	1290 Super		
	Adventure S	17-18	SP
	1290 Super		
	Adventure T	17-18	SP
<b>MOTO-GUZZI</b>			
	750 Brevia	03-09	HS

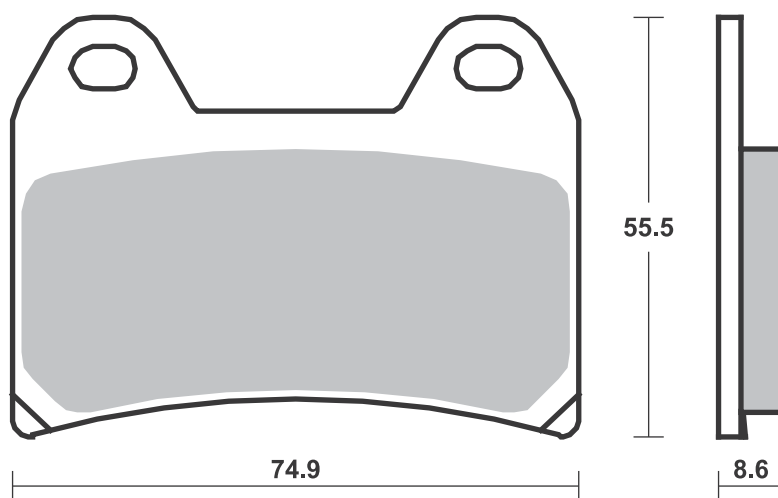



MOTO-GUZZI			
750 Nevada			
Classic ie	06-11	HF	
750 Nevada,			
Nevada			
Club	03-16	HF	
V7 750 Cafe Classic	10-13	HS	
V7 750 Classic	09-12	HS	
V7 750 Clubman			
Racer	10	HS	
V7 750 Racer	11-14	HS	
V7 750 Stone	12-14	HS	
V7 II 750 Racer	15-16	HS	
V7 II 750 Scrambler	16	HS	
V7 II 750 Special	15-16	HS	
V7 II 750 Stone	15-16	HS	
V7 II 750 Stornello	16	HS	
V7 II 750 Stornello			
Ltd. Edition	17-18	HS	
V7 III 750 Anniversario	17-18	HS	
V7 III 750 Carbon	18-	HS	
V7 III 750 Euro 4	17-18	HS	
V7 III 750 Milano	18-	HS	
V7 III 750 Racer	17-18	HS	
V7 III 750 Rough	18-	HS	
V7 III 750 Special	17-18	HS	
V7 III 750 Stone	17-18	HS	
V9 850 Bobber	16-17	HS	
V9 850 Roamer	16-17	HS	
V9 850 X-Track	17	HS	
940 Custom	07	HS	
1100 California			
EV	06	HS	
1100 California			
EV Touring	06	HS	
1100 California			
Jackal	01-06	HS	
1100 California			
Jackal			
Basic	01-06	HS	
1100 California			
Special	01	HS	
1100 California			
Special			
Sport Alloy	02-06	HS	
1100 California			
Stone Metal	02-03	HS	
1100 California			
Stone,			
Stone			
Touring	02-05	HS	
1100 California			
Titanium	03-05	HS	
1100 California			
Vintage	06-13	HS	
1100 Griso	05-10	HS	
EV 1100 California,			
80, Touring	01	HS	
V 1100 Brevia	04	HS	
V 1100 Brevia, ABS	05-07	HS	
V11 1100 , Scura,			
Sport Scura	02-05	HS	
V11 1100 Lemans,			
Lemans			
Tenni,			
Lemans			
Rosso			
Corsa	01-06	HS	



MOTO-GUZZI			
V11 1100 Sport Rosso			
Mandell	01-06	HS	
V11 1100 Sport,			
Sport			
Naked	01-05	HS	
1200 Griso 8V	07-13	HS	
1200 Griso 8V SE	18-	HS	
1200 Norge	06-14	HS	
1200 Norge			
GT 8V	10-13	HS	
1200 Sport	07-08	HS	
1200 Sport 4V	09-11	HS	
1200 Sport 8V	12-13	HS	
1200 Sport 8V SE	12-15	HS	
1200 Stelvio	08-11	SP	
1200 Stelvio 8V			
SE	12-16	SP	
1200 Stelvio NTX	09-11	SP	
V 1200 Brevia	08-13	HS	
1400 Audace	15-17	HS	
1400 California			
Custom	13-15	HS	
1400 California			
Touring	13-15	HS	
1400 California			
Touring SE	16-17	HS	
1400 Eldorado	15-17	HS	
MGX-21 1400 Flying			
Fortress	15-17	HS	
MOTO-MORINI			
1200 11 1/2	18-	HS	
1200 9 1/2	06-09	HS	
1200 Corsaro	06-13	HS	
1200 Sport	08-13	HS	
MOTUS			
MST 1650	14-17	HS	
MV AGUSTA			
675 Brutale	12-15	HS	
675 F3	11-14	HS	
800 Brutale	13-17	HS	
800 Brutale			
Dragster	15-18	HS	
800 Brutale			
Dragster RC	17-18	HS	
800 Brutale			
Dragster RR	15-18	HS	
800 Brutale			
Dragster			
RR LH44	18-	HS	
800 Brutale			
Dragster			
RR Pirelli	18-	HS	
800 Brutale RC	18-	HS	
800 Brutale RR	16-17	HS	
800 RVS#1	18-	HS	
920 Brutale	12-14	HS	
989 Brutale R	09	HS	
990 Brutale R	10-11	HS	
1090 Brutale R	12-15	HS	
MZ			
1000 (MUZ) S	01-02	HS	



NORTON			
961 Commando			
SE	10-11	HS	
961 Commando			
SF			
Sport	11-15	HS	
VICTORY			
Empulse TT	16-17	H.HS	
1500 Kingpin	04-05	H.HS	
1500 Touring C			
ruiser	03-06	H.HS	
1500 V92C			
Cruiser	98-02	H.HS	
1500 V92C			
Deluxe	01-02	H.HS	
1500 V92SC			
Sport			
Cruiser	00-02	H.HS	
1500 Vegas	03-05	H.HS	
1500 Vegas 8-Ball	05	H.HS	
1634 Hammer	05-07	H.HS	
1634 Hammer S	06-08	H.HS	
1634 Kingpin	06-07	H.HS	
1634 Kingpin Tour	06-07	H.HS	
1634 Vegas	06-07	H.HS	
1634 Vegas 8-Ball	06-07	H.HS	
1634 Vegas J			
ackpot	06-07	H.HS	
YAMAHA			
XT 660 X	04-13	HS	

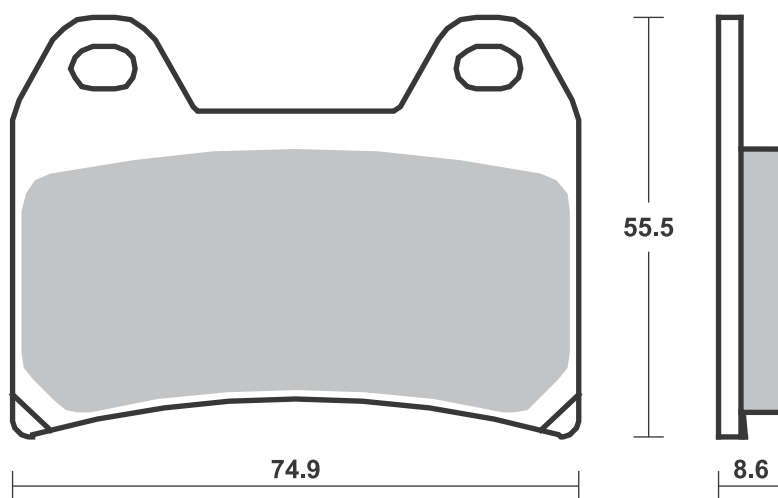

**SBS 707** Recommended compound



**A.P. RACING CALIPERS**

6 Piston 4466/4477 Series

**PFM**

6 Piston Racing Caliper

**SBS 708** Recommended compound



**SYM**

	125 Attila	95-02	<b>HF</b>
H01	150	95-00	<b>HF</b>

**ZERO**

DS	ZF6.0	10-12	<b>HF</b>
DS	ZF9.0	10-12	<b>HF</b>
MX		10-12	<b>HF</b>
S	ZF6.0	10-12	<b>HF</b>
X		10-12	<b>HF</b>
XU		11-12	<b>HF</b>

Brake Pad 1:1 Drawings,  
Compounds, Fitments

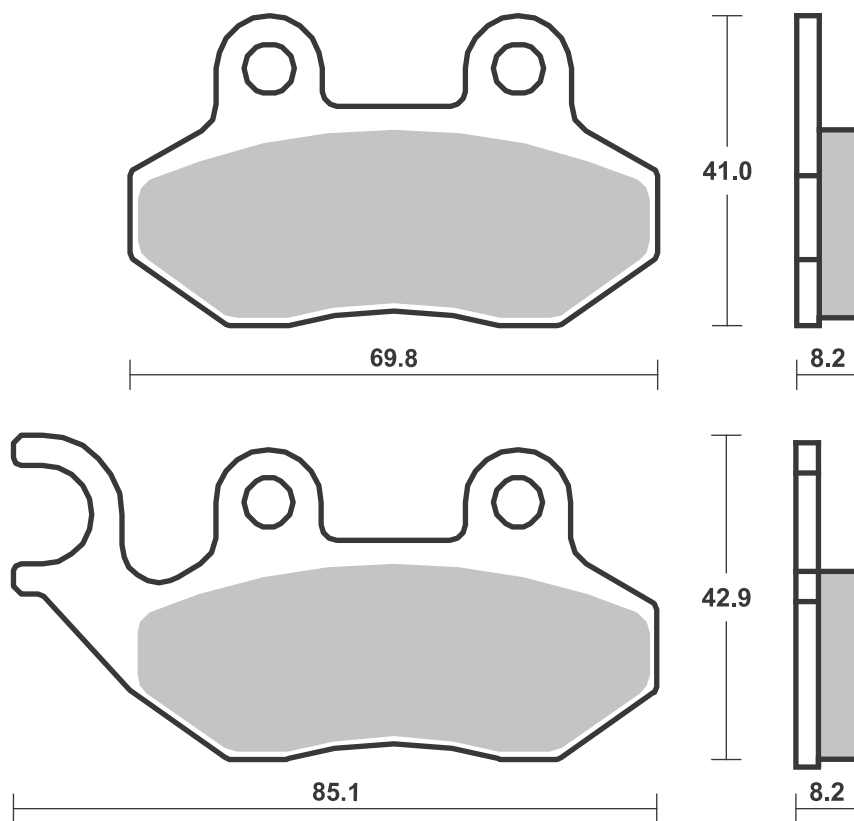
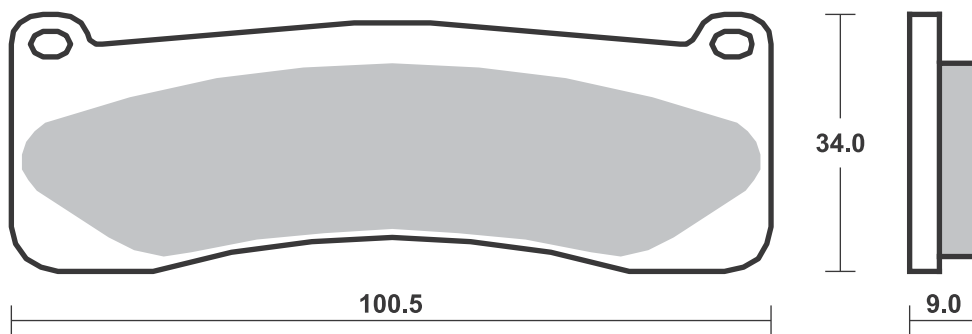





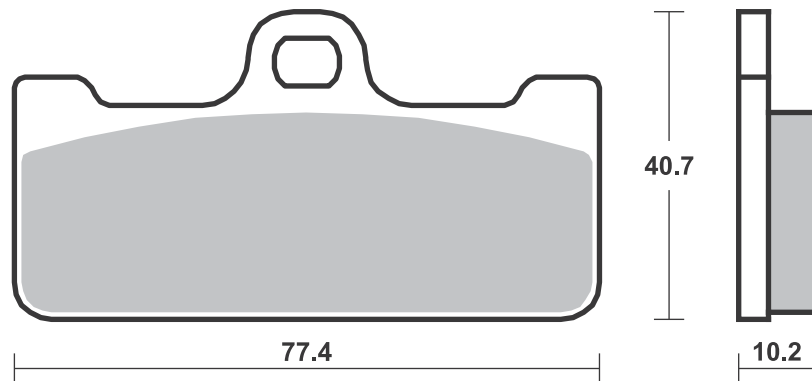
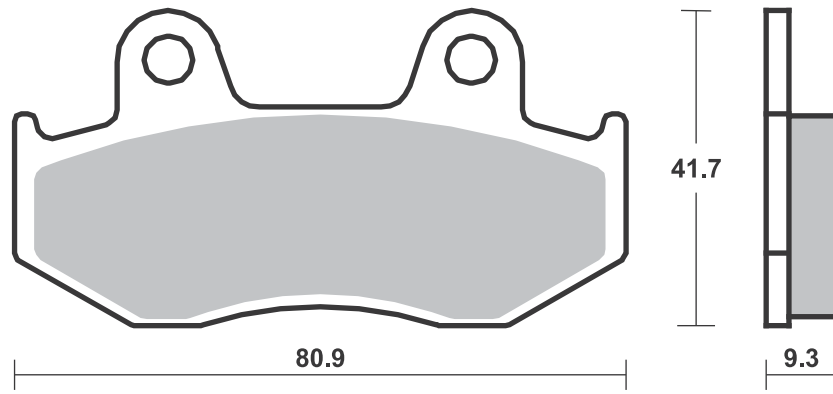



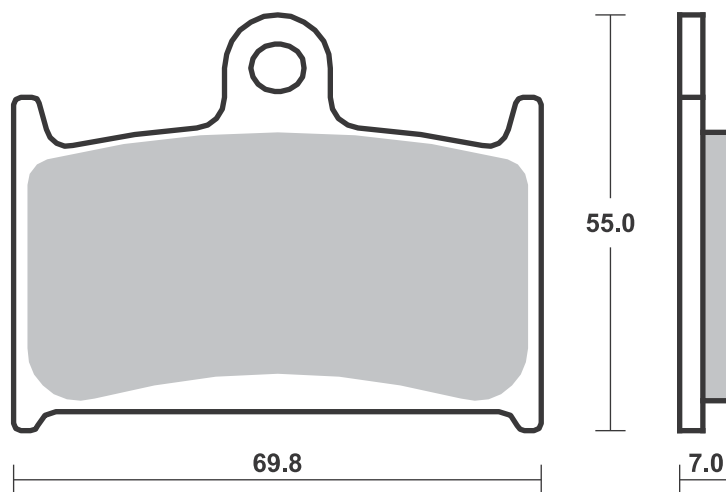
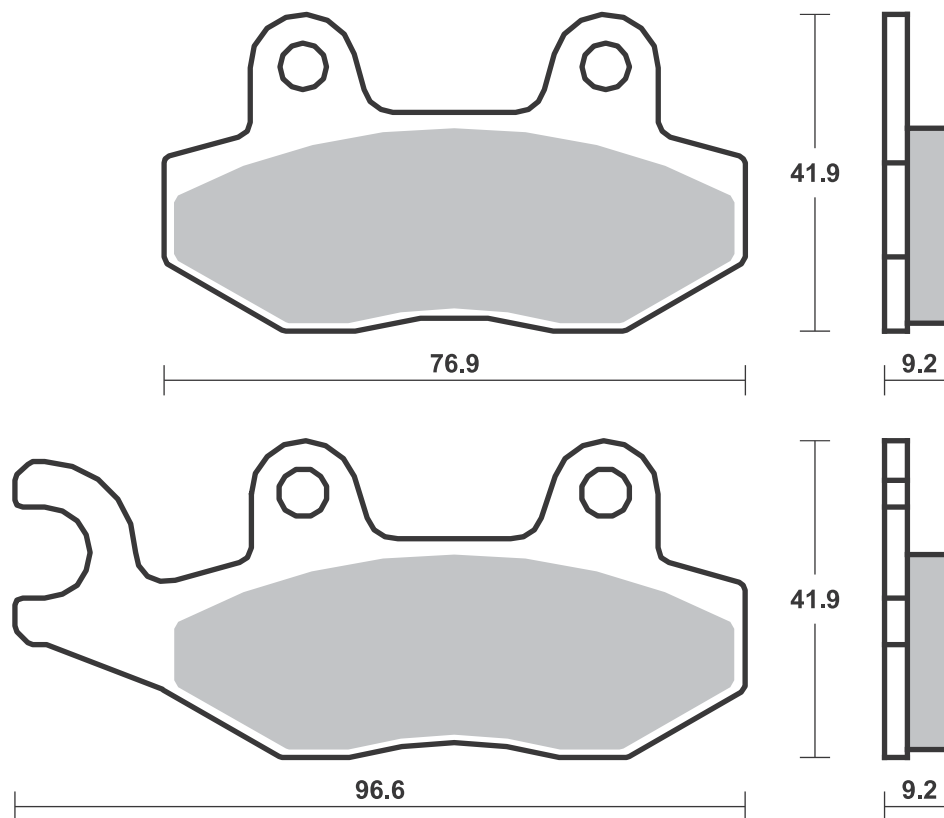

**SBS 715 Recommended compound**



<b>HARLEY DAVIDSON</b>			
XL	883 L Super Low	14-18	<b>H.LS</b>
XL	883 N Iron	14-18	<b>H.LS</b>
XL	883 R Roadster	14-15	<b>H.LS</b>
XL	1200 C, CA, CB, CP Custom	14-18	<b>H.LS</b>
XL	1200 CX	17	<b>H.LS</b>
XL	1200 Roadster	18-	<b>H.LS</b>
XL	1200 T Super Low	15-17	<b>H.LS</b>
XL	1200 V Seventy-Two	14-16	<b>H.LS</b>
XL	1200 X Forty-Eight	14-18	<b>H.LS</b>
<b>HONDA</b>			
VT	750 C2S ABS	13-14	<b>LS</b>
VT	750 CS ABS	13-14	<b>LS</b>



<b>HONDA</b>			
VT	750 Shadow		
	Aero	13-18	<b>LS</b>
CB	1300 R	02-04	<b>LS</b>
<b>KAWASAKI</b>			
ZX-7RR	750 Ninja	96-02	<b>LS</b>
ZG	1400 Concours	07-10	<b>LS</b>
ZX-14R	1400 Ninja	06-15	<b>LS</b>
ZX-14R	1400 Ninja ABS	07-15	<b>LS</b>
ZX-14R	1400 SE	16-18	<b>LS</b>
<b>MZ</b>			
	1000 (MUZ) S	03-10	<b>LS</b>
	1000 (MUZ) SF	05-10	<b>LS</b>
	1000 (MUZ) SFX	07	<b>LS</b>



<b>MZ</b>			
	1000 (MUZ) SN	05	<b>LS</b>
	1000 (MUZ) ST	07-10	<b>LS</b>

**SBS 716 Recommended compound**



<b>POLARIS</b>			
	250 2x4, 4x4	90-93	<b>ATS</b>
	250 Big Boss 4x6, 6x6	89-93	<b>ATS</b>
	250 Trail Blazer	90-07	<b>ATS</b>
	250 Trail Boss	91-99	<b>ATS</b>
	250 Trail Boss 2x4, 4x4	91-92	<b>ATS</b>
	250 Xplorer 4x4	00-02	<b>ATS</b>
	300 2x4, 4x4	94-95	<b>ATS</b>
	300 Big Boss 6x6	94	<b>ATS</b>
	300 Hawkeye 2x4, 4x4	07-11	<b>ATS</b> <b>ATS</b>
	300 Xplorer 4x4	96-99	<b>ATS</b>
	300 Xpress 2x4	98-99	<b>ATS</b>
	300 Xpress L	96-97	<b>ATS</b>
	325 Magnum 2x4, 4x4	00-02	<b>ATS</b>
	325 Trail Boss	00-02	<b>ATS</b>
	330 ATP	04-05	<b>ATS</b> <b>ATS</b>
	330 ATP	06-05	<b>ATS</b>
	330 Magnum 2x4, 4x4	03-13	<b>ATS</b>
	330 Trail Boss	03-14	<b>ATS</b>
	335 Sportsman 4x4	99-02	<b>ATS</b>
	350 Big Boss	93	<b>ATS</b>
	350 L 2x4, 4x4	90	<b>ATS</b>
	350 L 4x4	93	<b>ATS</b>
	350 Sportsman 4x4	93	<b>ATS</b>
	350 Trail Boss 2x4, 4x4	88-89	<b>ATS</b>
	350 Trail Boss L 2x4	91-93	<b>ATS</b>
	350 Trail Boss L 4x4	91	<b>ATS</b>
	400 Big Boss L 6x6	96	<b>ATS</b>
	400 L 2x4	94-95	<b>ATS</b>
	400 L 4x4	94	<b>ATS</b>
	400 Scrambler 2x4, 4x4	00-03	<b>ATS</b>



<b>POLARIS</b>			
	400 Scrambler 4x4	98-03	<b>ATS</b>
	400 Scrambler L 4x4	95-97	<b>ATS</b>
	400 Sport	99-00	<b>ATS</b>
	400 Sport L	94-98	<b>ATS</b>
	400 Sportsman	01-13	<b>ATS</b>
	400 Sportsman L 4x4	94-97	<b>ATS</b>
	400 Trail Blazer	03-04	<b>ATS</b>
	400 Xplorer L 4x4	95-02	<b>ATS</b>
	400 Xpress L	96-97	<b>ATS</b>
	425 2x4, 4x4 Magnum	95-98	<b>ATS</b>
	425 Magnum 6x6	96	<b>ATS</b>
	425 Xpedition 4x4	00-03	<b>ATS</b>
	450 Sportsman	06-09	<b>ATS</b>
	455 Diesel EBS 4x4	99-01	<b>ATS</b>
	500 ATP HO	04-05	<b>ATS</b> <b>ATS</b>
	500 Big Boss 6x6	98-99	<b>ATS</b>
	500 Magnum 2x4, 4x4	02-07	<b>ATS</b>
	500 Magnum 4x4	00-01	<b>ATS</b>
	500 Outlaw	06-09	<b>ATS</b> <b>ATS</b>
	500 Predator	03-13	<b>ATS</b> <b>ATS</b>
	500 Predator e	06-13	<b>ATS</b>
	500 Ranger 6x6	00-02	<b>ATS</b>
	500 Scrambler 2x4	01-02	<b>ATS</b>
	500 Scrambler 4x4	97-13	<b>ATS</b>
	500 Sportsman 4x4	96-14	<b>ATS</b>
	500 Sportsman 6x6	00-11	<b>ATS</b>
	500 Sportsman EBS 4x4	98-02	<b>ATS</b>
	500 Xplorer 4x4	97	<b>ATS</b>

Brake Pad 1:1 Drawings, Compounds, Fitments

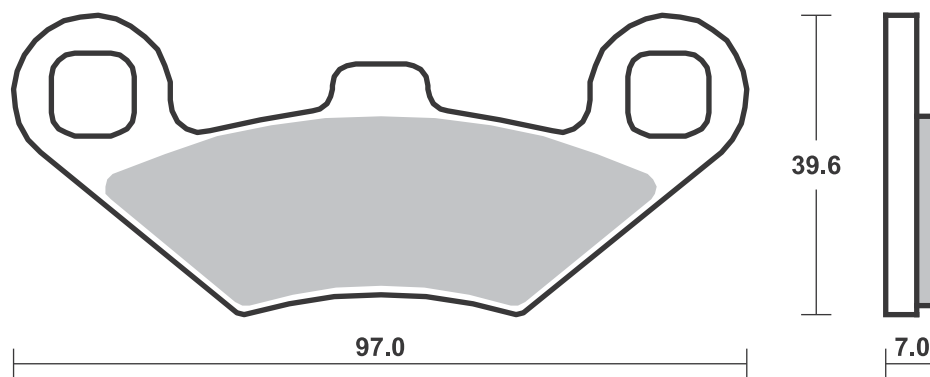
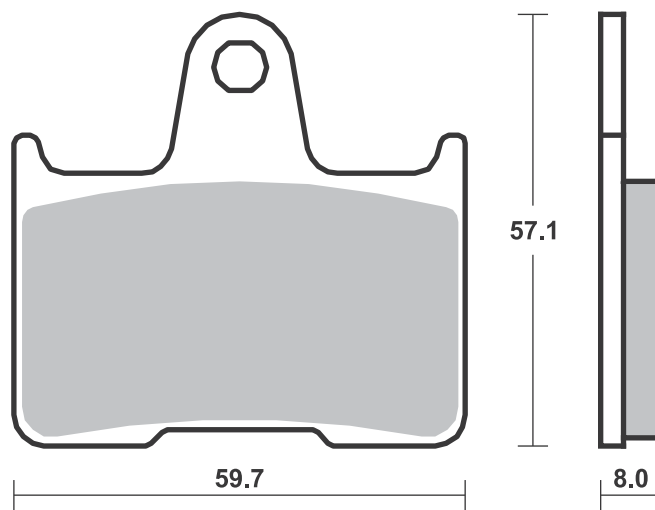



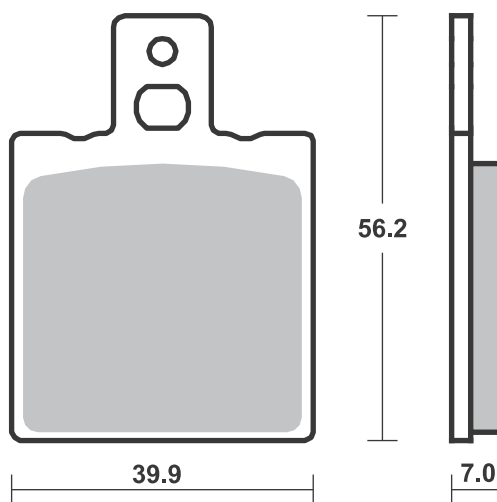
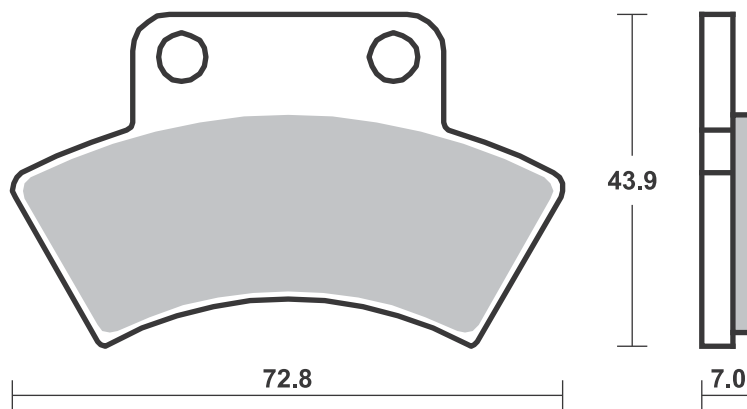





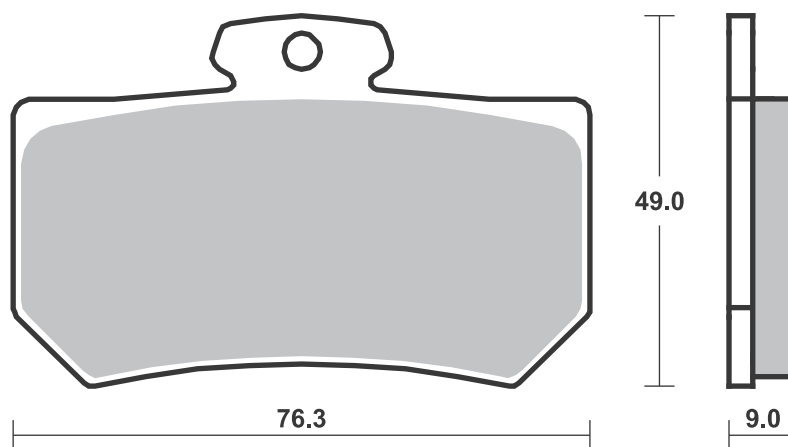
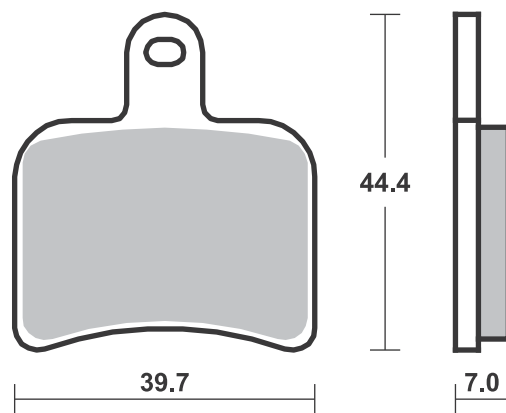



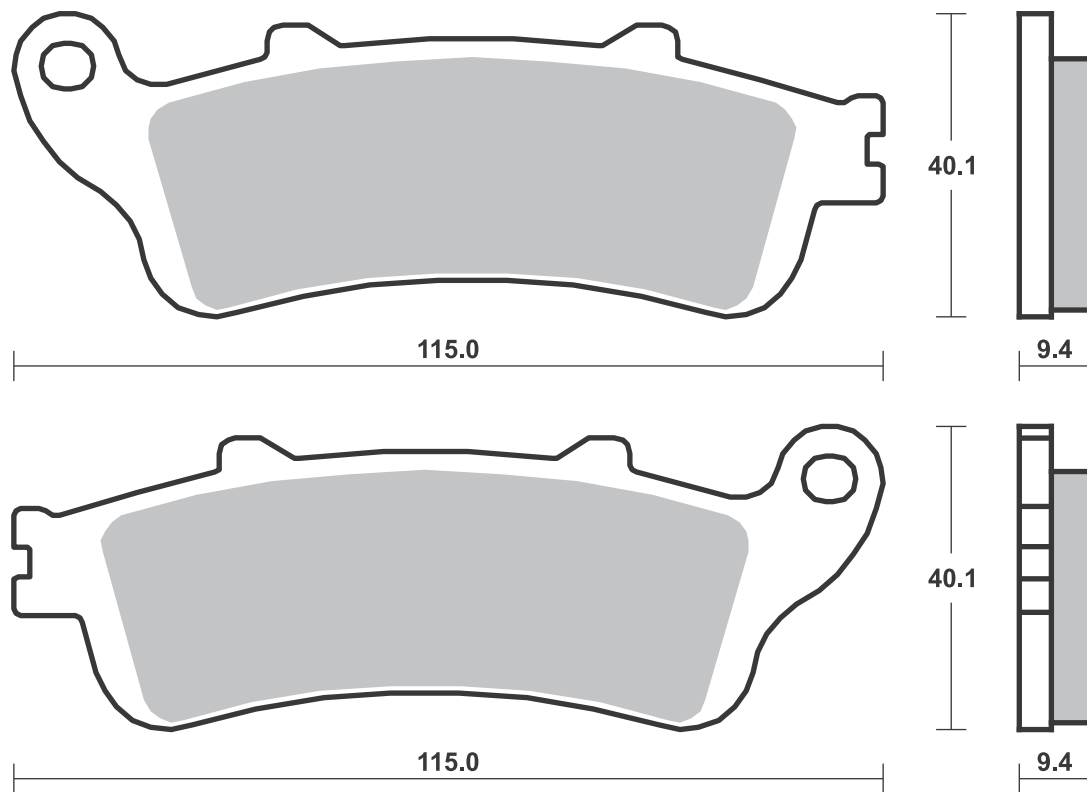
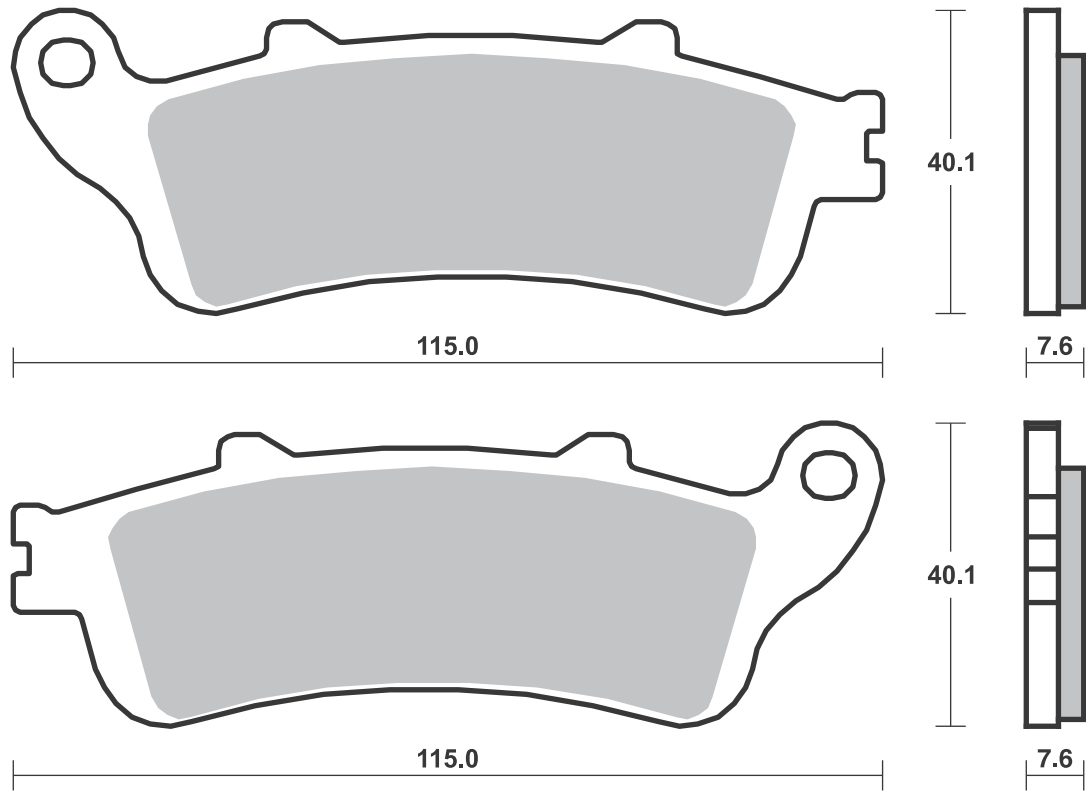



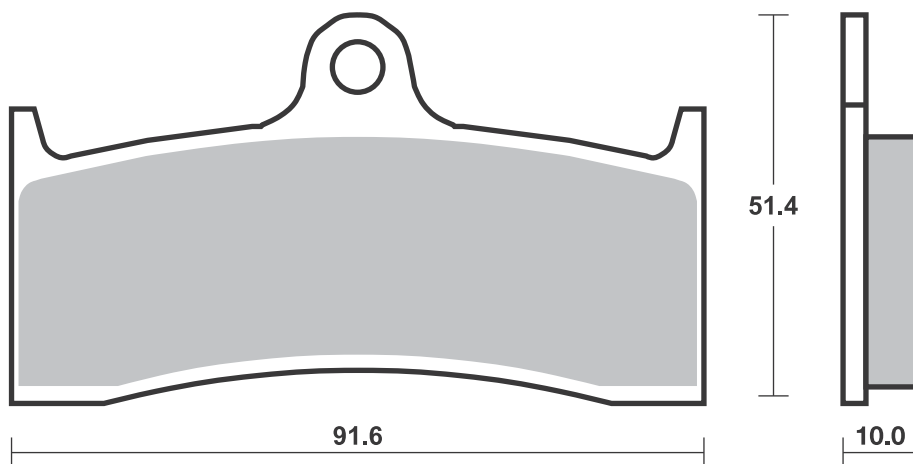
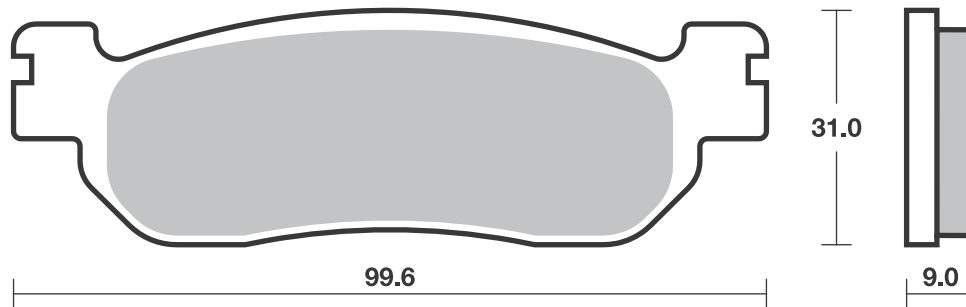
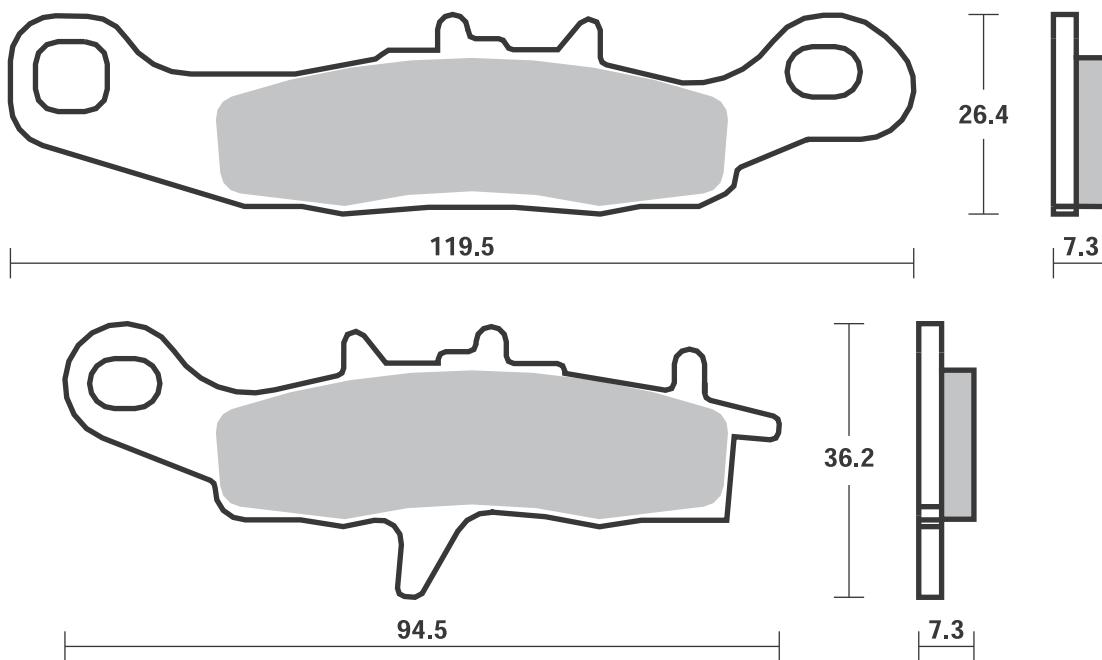



<b>APRILIA</b>			
	1000 Blue Marlin	02	LS
ETV	1000 Caponord	01-08	LS
ETV	1000 Caponord		
	Rally Raid	04-08	LS
RSV	1000 Factory		
	Pista	04	LS
RSV	1000 Falco SL,		
	R	00-04	LS
RSV	1000 Mille	97-03	LS
RSV	1000 Mille Nera	04	LS
RSV	1000 Mille R	00-04	LS
RSV	1000 Mille R	03	LS
RSV	1000 Mille R	05-07	LS
RSV	1000 Mille R		
	Factory	04-05	LS
RSV	1000 Mille SP	00	LS
RSV	1000 Tuono		
	Fighter	03-05	LS
RSV	1000 Tuono R	03	LS
RSV	1000 Tuono R,		
	ABS	04-12	LS
RSV	1000 Tuono R		
	Factory,		
	ABS	06-12	LS
RSV	1000 Tuono		
	V4 R	11-14	LS
RSV4	1000 , ABS	09-13	LS
RSV4-R	1000 , ABS		
	APRC	10	LS
RSV4-RF	1000	15-18	LS
RSV4-RR	1000	15-18	LS
RSV	1100 Tuono V4	15	LS
RSV	1100 Tuono V4		
	Factory	16-18	LS
RSV	1100 Tuono V4		
	RR	15-18	LS
<b>BENELLI</b>			
	500 Leoncino	16-17	LS
TRK	502	16-17	LS
BN	600	12-17	LS
BN	600 GT	14-15	LS
	756 Cue	07-12	LS
	899 Trek	07-12	LS
TnT	899	07-15	LS
TnT	899 Century		
	Racer	11	LS
	900 Tornado		
	TRE	03-06	LS
	900 Tornado		
	TRE RS	04-06	LS
TnT	1130	05-14	LS
TnT	1130 Cafe Racer	05-13	LS
TnT	1130 Century		
	Racer	11-12	LS
TnT	1130 Officine	07	LS
TnT	1130 R	17	LS
TnT	1130 Sport	05-08	LS
TnT	1130 Titanium	05-08	LS
TnT	1130 Trek	06-12	LS
TnT	1130 Trek		
	Amazonas	07-15	LS
<b>BIMOTA</b>			
3D	800 Tesi	16	LS
BB3	1000	14-18	LS
DB5	1000 Mille	05-11	LS



<b>BIMOTA</b>			
DB5	1000 S	07-11	LS
DB6	1000 Delirio	07-09	LS
DB10	1078 Bimotard	12	LS
DB5	1078 RE	12	LS
DB7	1098	08	LS
3D	1100 Tesi	07-11	LS
DB6R	1100 Delirio	08-09	LS
DB8	1198	10-14	LS
	1200 Impeto	16-17	LS
DB11	1200 VLX	13	LS
DB12	1200	12	LS
DB9	1200 Brivido	12-18	LS
<b>BOMBARDIER</b>			
	500 Traxter 4x4	99-00	HF HF
<b>BRAMMO</b>			
	Empulse	14-16	LS
<b>BREMO RACING CALIPERS</b>			
	Goldline 20.6951.50, road		
	Supersport 120A44110,		
	P2 34		
<b>CAGIVA</b>			
	650 Raptor	01-08	LS
	650 V-Raptor	01-08	LS
	1000 Raptor	00-08	LS
	1000 V-Raptor	00-08	LS
	1000 X3 Raptor	04	LS
	1000 X-Raptor	03-04	LS
	1000 Xtra Raptor	02-06	LS
<b>DERBI</b>			
GP1	50	05	HF
GPR	50 Nude	04-10	HF
GPR	50 Racing	04-13	HF
GP1	125	05-06	HF
GP1	250	05-09	HF
	659 Mulhacen	05-07	LS
	659 Mulhacen		
	Cafe	08	LS
<b>DUCATI</b>			
	620 Multistrada	05-06	LS
	620 Multistrada		
	Dark	05-06	LS
	620 Sport	03-06	LS
	696 Monster	08-12	LS
	749 , S	03-07	LS
	749 R	04-07	LS
	750 Sport	00-02	LS
	750 Super Sport	00-02	LS
	795 Monster	12	LS
	796 Hypermotard		
	ABS	10-12	LS
	796 Monster	11-14	LS
	796 Monster ABS	11-14	LS
	800 Hypermotard	13-15	LS
	800 Hypermotard		
	ABS	13-15	LS
	800 Hypermotard		
	SP	13-15	LS
	800 Hypermotard		
	SP ABS	13-15	LS
	800 Hyperstrada	13-15	LS



<b>DUCATI</b>			
	800 Hyperstrada		
	ABS	13-15	LS
	800 Sport	03-06	LS
	800 Supersport	03-06	LS
	821 Monster	14-18	LS
	821 Monster Dark	15-16	LS
	848	08-10	LS
	848 EVO	11-12	LS
	848 Streetfighter	12-15	LS
	848 Streetfighter S	12-15	LS
	899 Panigale	14-15	LS
	900 Super Sport	98-02	LS
	916 Sport		
	Touring 4	99-01	LS
	939 Hypermotard	16-18	LS
	939 Hypermotard		
	SP	16-18	LS
	939 Hyperstrada	16	LS
	939 SuperSport	17-18	LS
	939 SuperSport S	17-18	LS
	944 Sport Touring	98-03	LS
	944 ST2	97-03	LS
	959 Panigale	16-18	LS
	959 Panigale		
	Corse	18-	LS
D16RR	990 Desmosedici		
	RR	07-08	LS
	992 ST3	04-07	LS
	992 ST3s ABS	06-07	LS
	996 ST4s	02-06	LS
	996 ST4s ABS	03-06	LS
	998 Monster S4Rs	06	LS
	999 , S	03-07	LS
	999 Monster S4R	07-08	LS
	999 Monster		
	S4RS	07-08	LS
	999 R	03-07	LS
	1000 Hypermotard	06	LS
	1000 Monster S2R	06-07	LS
	1000 Multistrada	07	LS
	1000 Multistrada		
	DS	03-06	LS
	1000 Multistrada		
	S DS	05-06	LS
	1000 Supersport		
	DS	03-06	LS
	1098	07-08	LS
	1098 R	08-10	LS
	1098 R Bayliss LE	09-10	LS
	1098 S	07-08	LS
	1098 Streetfighter	09-14	LS
	1098 Streetfighter S	09-13	LS
	1100 Hypermotard	07-13	LS
	1100 Hypermotard		
	EVO	10-13	LS
	1100 Hypermotard		
	EVO SP	10-12	LS
	1100 Monster	09-13	LS
	1100 Monster ABS	09-10	LS
	1100 Monster EVO	11-13	LS
	1100 Monster EVO		
	ABS	11-13	LS
	1100 Monster S	09-13	LS
	1100 Monster S		
	ABS	09-10	LS
	1100 Multistrada	07-09	LS
	1100 Multistrada S	07-09	LS

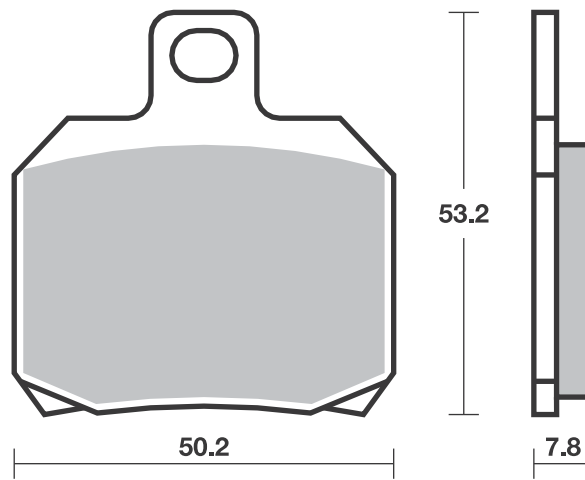



<b>DUCATI</b>			
1100 Panigale			
V4	18-	<b>LS</b>	
1100 Panigale			
V4 S	18-	<b>LS</b>	
1100 Panigale			
V4			
Speciale	18-	<b>LS</b>	
1198	09-13	<b>LS</b>	
1198 S	09-12	<b>LS</b>	
1198 SP	11-12	<b>LS</b>	
1199 Panigale	12-14	<b>LS</b>	
1199 Panigale R	13-15	<b>LS</b>	
1199 Panigale S	12-14	<b>LS</b>	
1199 Superleggera			
14		<b>LS</b>	
1200 Monster	14-18	<b>LS</b>	
1200 Monster R	16-18	<b>LS</b>	
1200 Monster S	14-18	<b>LS</b>	
1200 Multistrada	10-14	<b>LS</b>	
1200 Multistrada			
S GT	12-14	<b>LS</b>	
1200 Multistrada			
S Pikes			
Peak	11-14	<b>LS</b>	
1200 Multistrada			
S Sport	10-14	<b>LS</b>	
1200 Multistrada			
S Touring	10-14	<b>LS</b>	
1299 Panigale	15-17	<b>LS</b>	
1299 Panigale R	15-17	<b>LS</b>	
1299 Panigale R			
Final			
Edition	17-18	<b>LS</b>	
1299 Panigale S	15-17	<b>LS</b>	
1299 Panigale S			
Anniversario			
17		<b>LS</b>	
1299 Superleggera			
17		<b>LS</b>	
<b>GILERA</b>			
600 Supersport 02		<b>LS</b>	
<b>HONDA</b>			
RC213V-S 1000	16-18	<b>LS</b>	
<b>KAWASAKI</b>			
ZX 1000 H2 Carbon			
Ninja	17-18	<b>LS</b>	
ZX 1000 H2 Ninja	15-18	<b>LS</b>	
ZX 1000 H2R Ninja	15-18	<b>LS</b>	
<b>KTM</b>			
RC8 1190	08-11	<b>LS</b>	
RC8 1190 R	09-15	<b>LS</b>	
RC8 1190 R Track	11-15	<b>LS</b>	
1290 Super			
Duke GT	16-18	<b>LS</b>	
1290 Super			
Duke R	14-18	<b>LS</b>	
<b>LAVERDA</b>			
TTS 800	99	<b>HF</b>	
SFC 1000	04	<b>LS</b>	



<b>MONDIAL</b>			
1000 EVO	04	<b>LS</b>	
1000 Piega	03-04	<b>LS</b>	
1000 RZ Nuda	04	<b>LS</b>	
1000 Starfighter	04	<b>LS</b>	
<b>MOTO-GUZZI</b>			
750 Brevia	03-09	<b>LS</b>	
750 Nevada			
Classic ie	06-11	<b>HF</b>	
750 Nevada,			
Nevada Club	03-16	<b>HF</b>	
V7 750 Cafe Classic	10-13	<b>LS</b>	
V7 750 Classic	09-12	<b>LS</b>	
V7 750 Clubman			
Racer	10	<b>LS</b>	
V7 750 Racer	11	<b>LS</b>	
V 1100 Brevia	04	<b>LS</b>	
1200 MGS-01			
Corsa	05-13	<b>LS</b>	
1200 Sport 4V	09-11	<b>LS</b>	
<b>MOTO-MORINI</b>			
1200 11 1/2	18-	<b>LS</b>	
1200 9 1/2	06-09	<b>LS</b>	
1200 Corsaro	06-13	<b>LS</b>	
1200 Corsaro ZZ	18-	<b>LS</b>	
1200 Milano	18-	<b>LS</b>	
1200 Scrambler	18-	<b>LS</b>	
1200 Sport	08-13	<b>LS</b>	
<b>MOTUS</b>			
MST 1650	14-17	<b>LS</b>	
MST-R 1650	14-17	<b>LS</b>	
<b>MV AGUSTA</b>			
675 Brutale	12-15	<b>LS</b>	
675 F3	13-17	<b>LS</b>	
675 F3 RC	16-17	<b>LS</b>	
800 Brutale	13-17	<b>LS</b>	
800 Brutale			
Dragster	15-18	<b>LS</b>	
800 Brutale			
Dragster RC	17-18	<b>LS</b>	
800 Brutale			
Dragster RR	15-18	<b>LS</b>	
800 Brutale			
Dragster RR			
LH44	18-	<b>LS</b>	
800 Brutale			
Dragster			
RR Pirelli	18-	<b>LS</b>	
800 Brutale RC	18-	<b>LS</b>	
800 Brutale RR	16-17	<b>LS</b>	
800 F3 RC	16-17	<b>LS</b>	
800 Rivale	13-17	<b>LS</b>	
800 RVS#1	18-	<b>LS</b>	
800 Stradale	15-16	<b>LS</b>	
800 Turismo			
Veloce	14-16	<b>LS</b>	
800 Turismo			
Veloce Lusso	14-16	<b>LS</b>	
800 Turismo			
Veloce RC	17-18	<b>LS</b>	
<b>NORTON</b>			
961 Commando			
Cafe Racer			
MKII	18-	<b>LS</b>	
961 Commando			
SE	10-14	<b>LS</b>	
961 Commando			
SF	13-15	<b>LS</b>	
961 Commando			
SF Sport	11-15	<b>LS</b>	
961 Commando			
Sport	18-	<b>LS</b>	
961 Dominator			
Naked	17-18	<b>LS</b>	
1200 V4 RR	18-	<b>LS</b>	
<b>VICTORY</b>			
Empulse TT	16-17	<b>H.LS</b>	



<b>NORTON</b>			
961 Commando			
Cafe Racer			
MKII	18-	<b>LS</b>	
961 Commando			
SE	10-14	<b>LS</b>	
961 Commando			
SF	13-15	<b>LS</b>	
961 Commando			
SF Sport	11-15	<b>LS</b>	
961 Commando			
Sport	18-	<b>LS</b>	
961 Dominator			
Naked	17-18	<b>LS</b>	
1200 V4 RR	18-	<b>LS</b>	
<b>VICTORY</b>			
Empulse TT	16-17	<b>H.LS</b>	



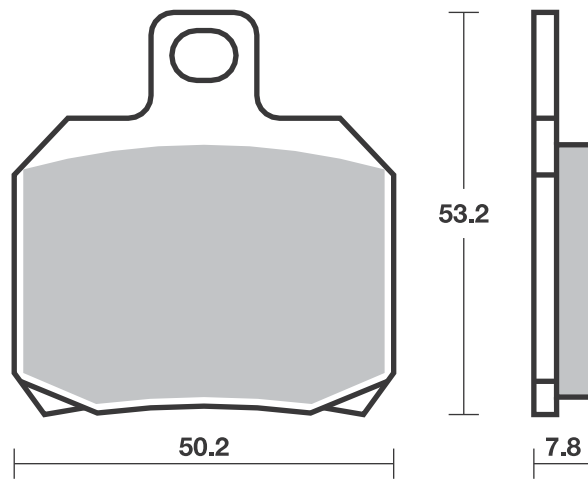



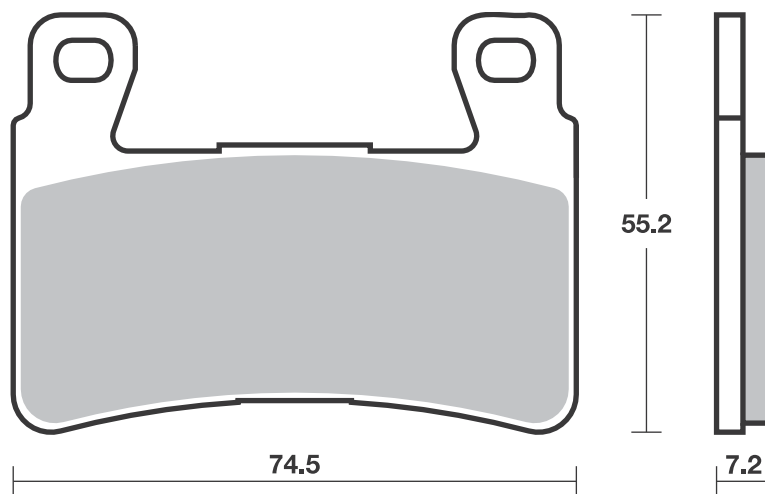
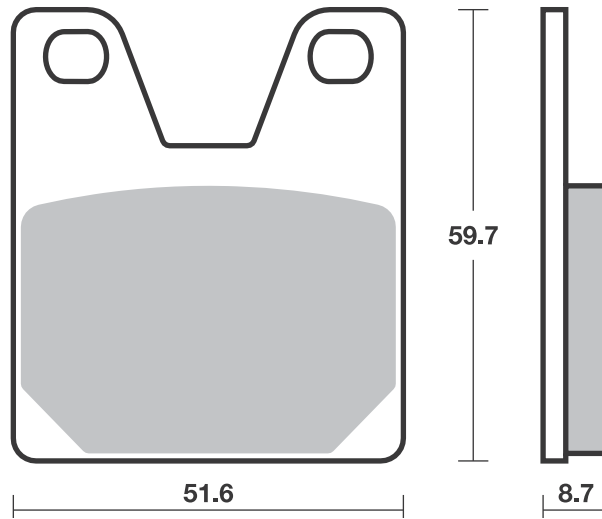
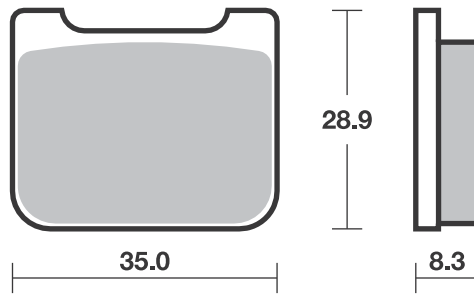

HF / HS / SP - Th. 7.2  
RS / DC - Th. 8.0

**SBS 735** Recommended compound

<b>HONDA</b>			
NT	650 V Deauville	02-05	<b>HS</b>
VFR	800 FI Interceptor,		
	ABS	02-05	<b>HS</b>
VFR	800 Interceptor	98-01	<b>HS</b>
CB	1100 X-11	00-03	<b>HS</b>
CBR	1100 XX Super		
	Blackbird	96-07	<b>HS</b>
ST	1300 , ABS	02-07	<b>HS</b>
GL	1800 Gold Wing	01-16	<b>HS</b>
GL	1800 Gold Wing		
	F6B	13-16	<b>HS</b>
NRX	1800 Valkyrie Rune	04-05	<b>HS</b>
VTX	1800	01-12	<b>HS</b>
<b>KAWASAKI</b>			
EN	650 Vulcan S	15-18	<b>HS</b>
EN	650 Vulcan S		
	Cafe	17-18	<b>HS</b>
EN	650 Vulcan S SE	17-18	<b>HS</b>
EX	650 Ninja ABS	17-18	<b>HS</b>
EX	650 Ninja KRT		
	ABS	17-18	<b>HS</b>
<b>VICTORY</b>			
	1731 Vision		
	all models	08-17	<b>H.HS</b>

**SBS 736** Recommended compound

<b>HONDA</b>			
NT	650 V Deauville	02-05	<b>LS</b>
NT	700 Deauville		
	ABS	06-12	<b>LS</b>
NT	700 V Varadero,		
	ABS	10-13	<b>LS</b>
VFR	800 FI Interceptor,		
	ABS	02-05	<b>LS</b>
VFR	800 Interceptor	98-01	<b>LS</b>
VFR	800 Interceptor	06-18	<b>LS</b>
VFR	800 Interceptor		
	ABS	06-18	<b>LS</b>
CB	1100 X-11	00-03	<b>LS</b>
CBR	1100 XX Super		
	Blackbird	96-07	<b>LS</b>
VT	1300 CXA A Fury		
	ABS	10-18	<b>LS</b>
NRX	1800 Valkyrie Rune	04-05	<b>LS</b>
VTX	1800	01-12	<b>LS</b>

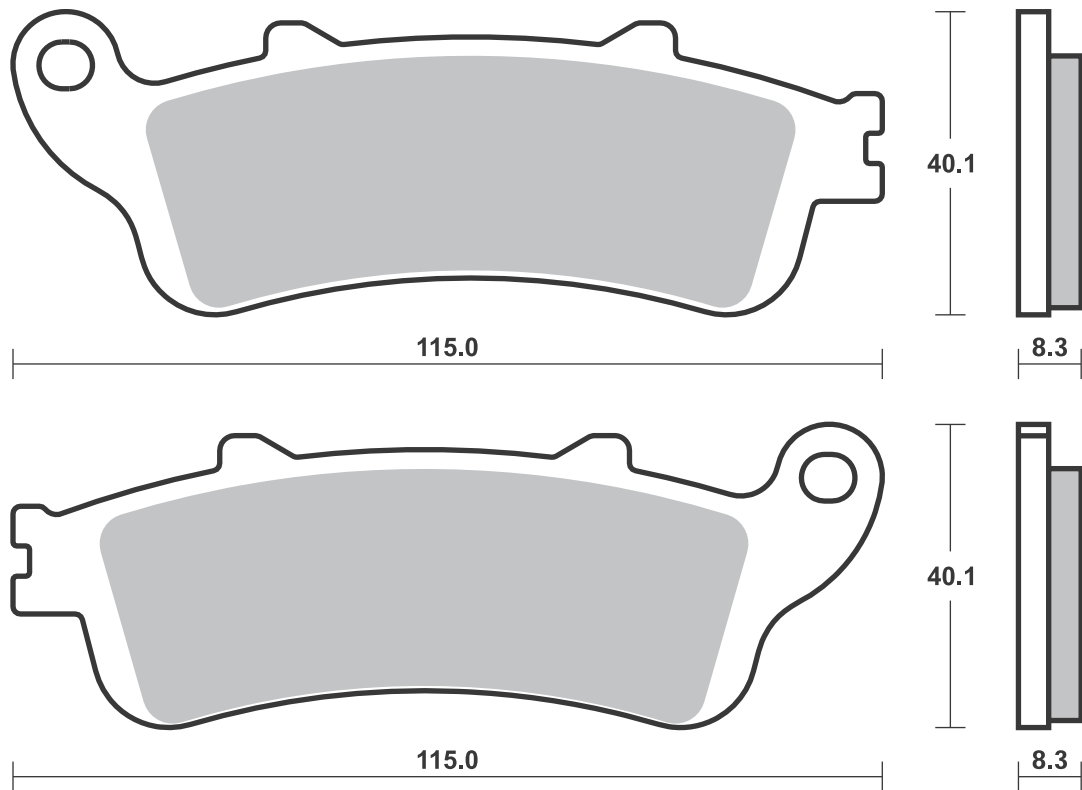
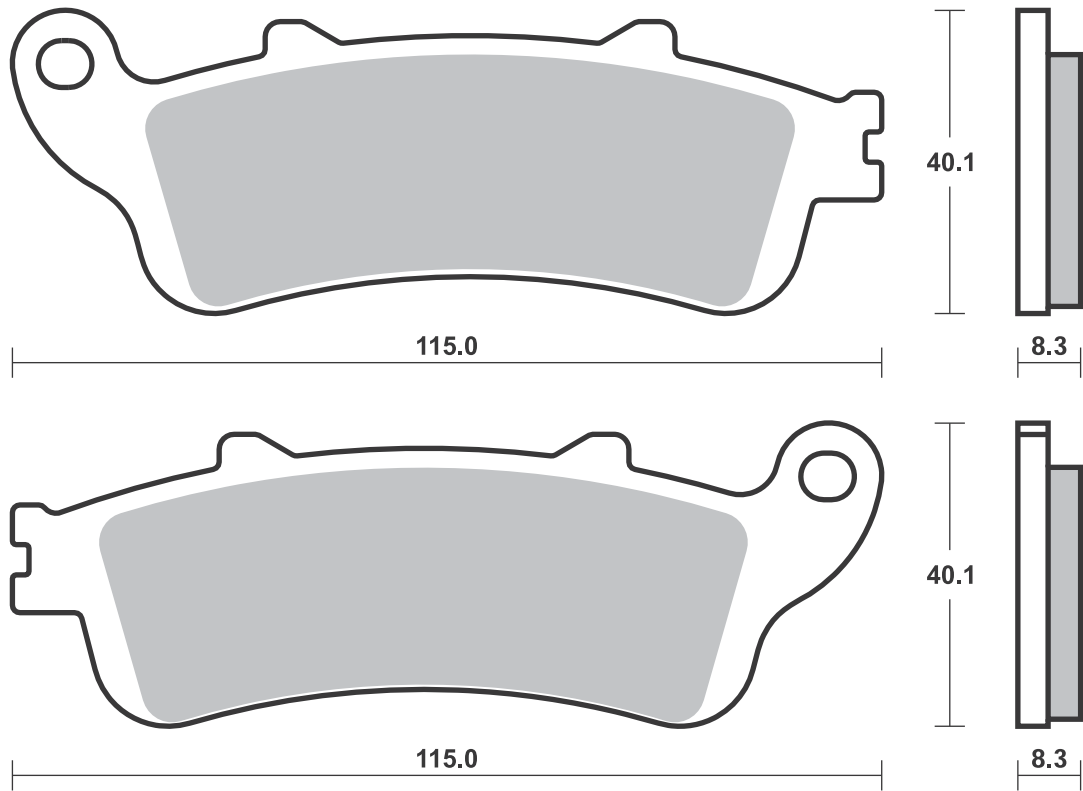



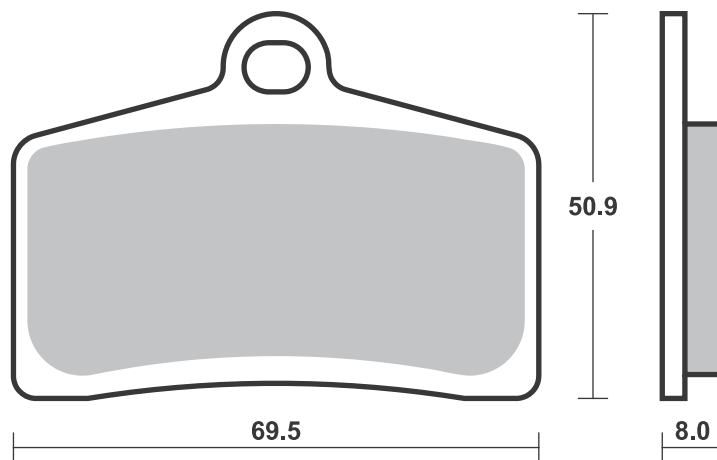
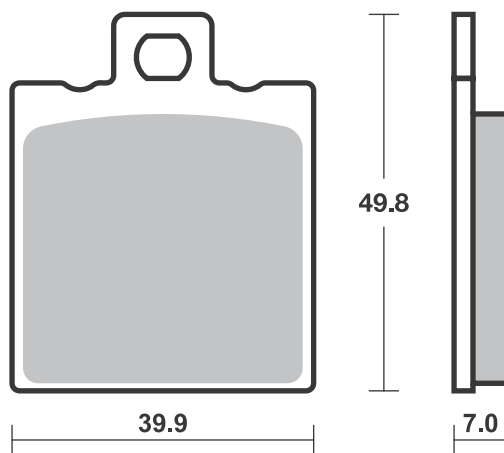

1 set = 4 pcs.

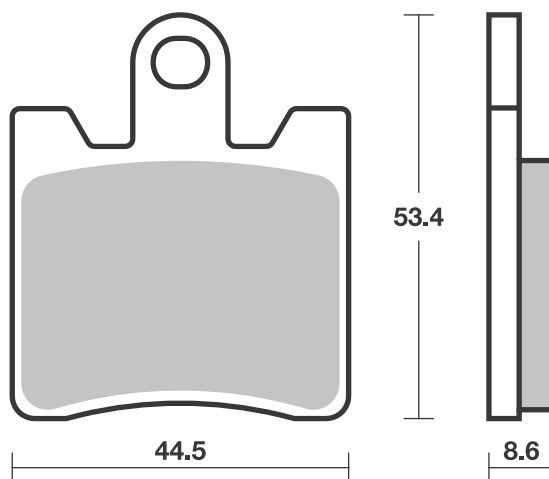





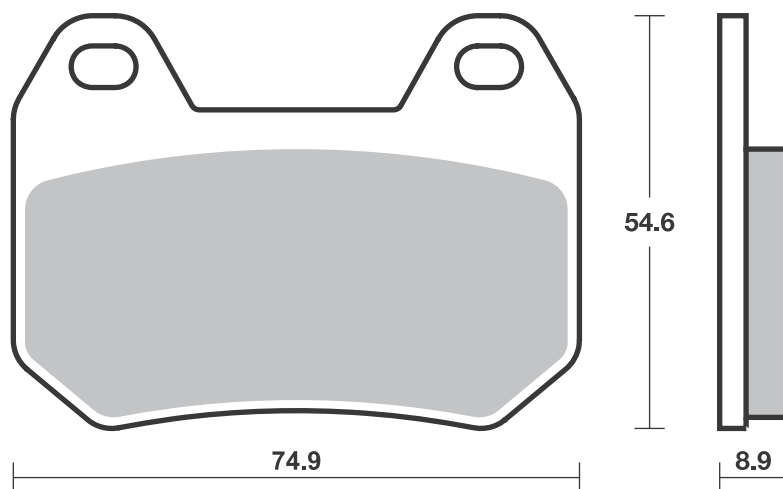
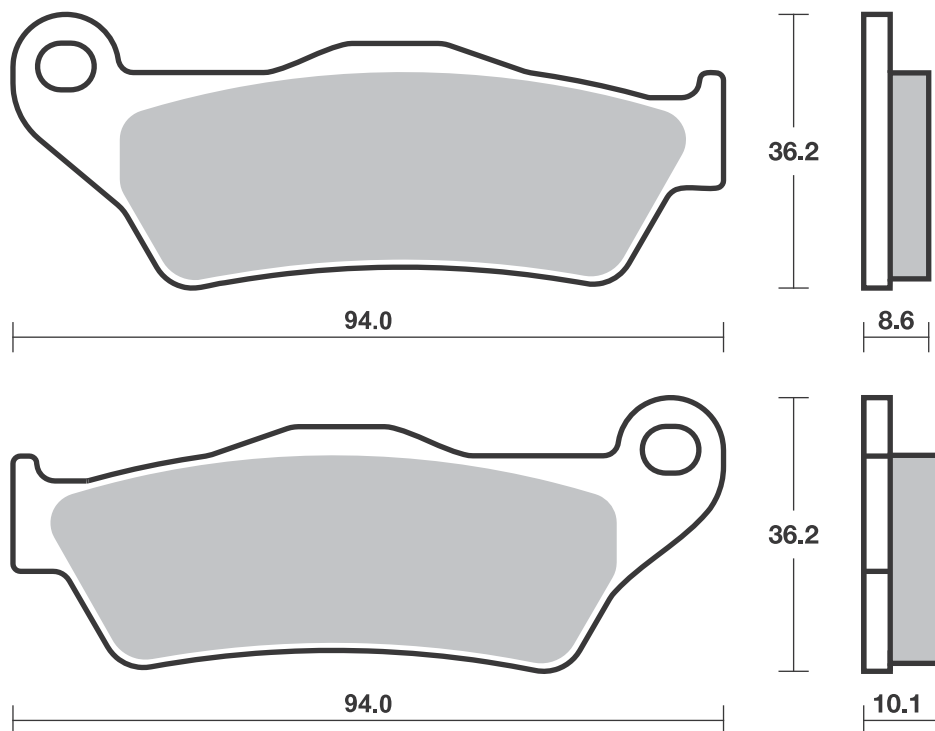



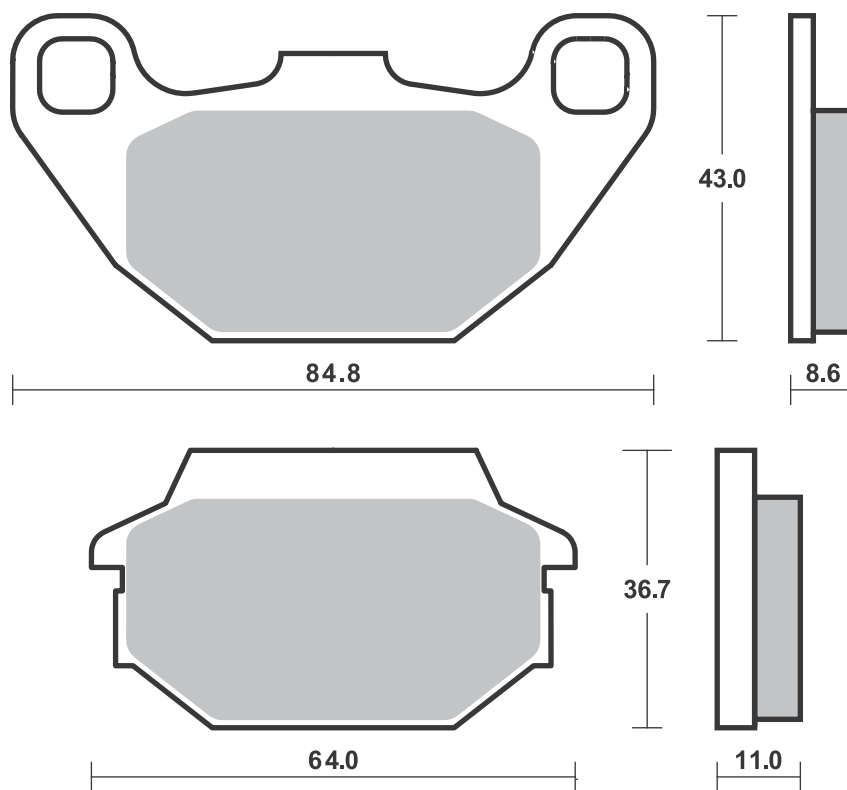
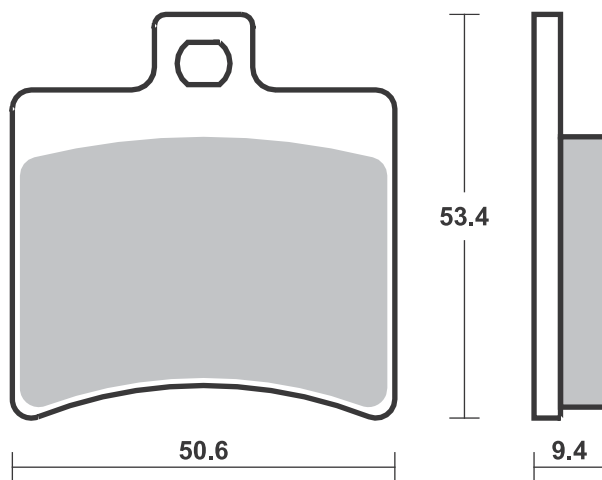



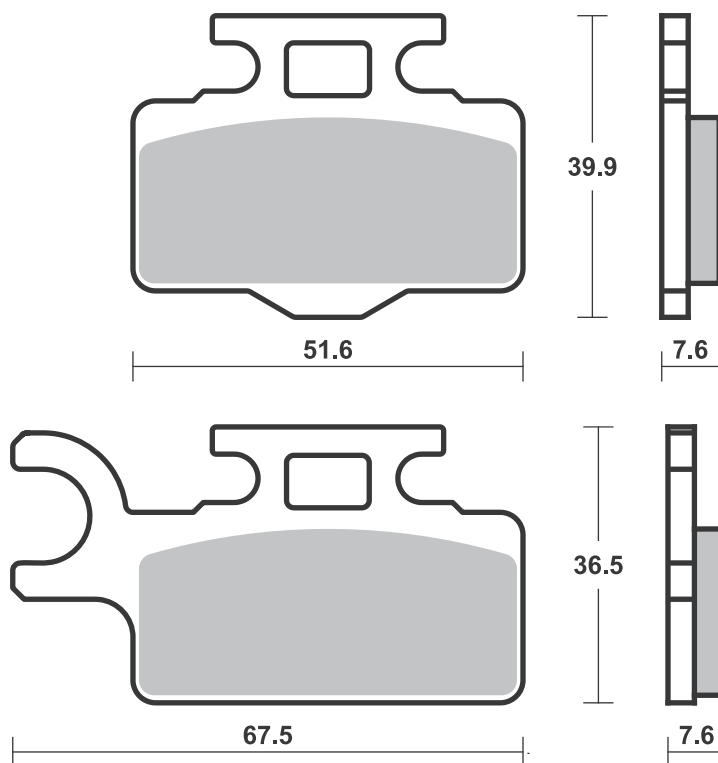
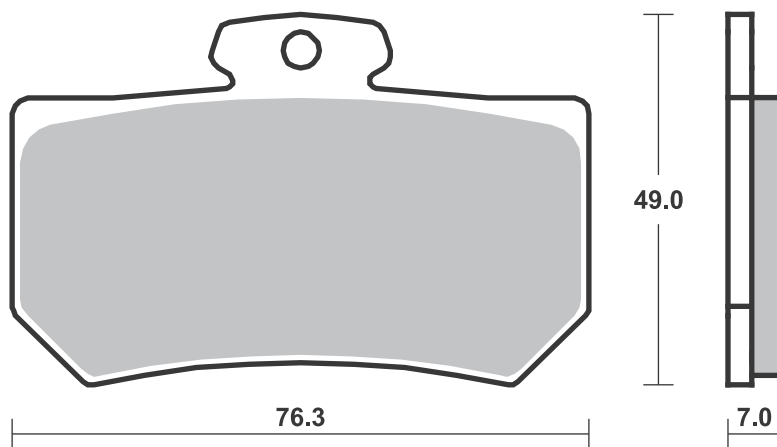

**SBS 754** Recommended compound

<b>BOMBARDIER</b>				
DS	250 Left/Rear	06	SI	SI
	330 Outlander			
	Left/Rear	03-06	SI	SI
	400 Outlander			
	Left/Rear	03-06	SI	SI
	400 Outlander Max			
	Left/Rear	03-06	SI	SI
	500 Quest			
	Left/Rear	02-06	SI	SI
	500 Traxter 4x4			
	Left/Rear	01-06	SI	
	500 Traxter Max			
	Left/Rear	03-05	SI	
	650 Quest			
	Left/Rear	02-06	SI	SI
	650 Quest Max			
	Left/Rear	03-06	SI	
	650 Traxter Max			
	Left/Rear	03-05	SI	
DS	650 Left/Rear	01-06	SI	SI
	800 Outlander			
	Left/Rear	06	SI	SI
	800 Outlander X			
	T Left/Rear	06	SI	SI

<b>CAN-AM</b>				
	400 Outlander			
	Efi Left/Rear	09-14	SI	SI
	400 Outlander MAX			
	STD Left/Rear	07-13	SI	SI
	400 Outlander			
	MAX XT			
	Left/Rear	07-13	SI	SI
	400 Outlander			
	STD Left/Rear	07-14	SI	SI
	400 Outlander XT			
	Left/Rear	07-14	SI	SI
	500 Outlander MAX			
	STD Left/Rear	07-12	SI	SI

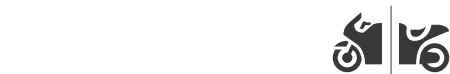

<b>CAN-AM</b>				
	500 Outlander MAX			
	XT Left/Rear	07-12	SI	SI
	500 Outlander STD			
	Left/Rear	07-12	SI	SI
	500 Outlander XT			
	Left/Rear	07-12	SI	SI
	500 Renegade			
	Left/Rear	08-11	SI	SI
	650 Outlander MAX			
	STD Left/Rear	07-12	SI	SI
	650 Outlander MAX			
	XT Left/Rear	07-12	SI	SI
	650 Outlander STD			
	Left/Rear	07-12	SI	SI
	650 Outlander XT			
	Left/Rear	07-12	SI	SI
	800 Outlander MAX			
	LTD Left/Rear	07-11	SI	SI
	800 Outlander MAX			
	STD Left/Rear	07-11	SI	SI
	800 Outlander MAX			
	XT Left/Rear	07-11	SI	SI
	800 Outlander STD			
	Left/Rear	07-11	SI	SI
	800 Outlander XT			
	Left/Rear	07-11	SI	SI
	800 Renegade Efi			
	Left/Rear	07-11	SI	SI
	800 Renegade			
	Left/Rear	08-11	SI	SI
	800 Renegade X			
	Left/Rear	08-11	SI	SI
	1000 Commander			
	MAX Left	14-18	SI	
	1000 Maverick Left	13-18	SI	

<b>CANNONDALE</b>				
	440 Blaze			
	Left/Rear	03	SI	SI



<b>CANNONDALE</b>				
	440 Cannibal			
	Left/Rear	03	SI	SI
	440 Glamis			
	Left/Rear	03	SI	SI
	440 Moto			
	Left/Rear	03	SI	SI
	440 Speed			
	Left/Rear	03	SI	SI

<b>JOHN DEERE</b>				
	500 Buck EX, EXT			
	Left/Rear	05	SI	
	500 Buck			
	Left/Rear	05	SI	
	500 Trail Buck			
	Left/Rear	05	SI	
	650 Trail Buck EX,			
	EXT Left/Rear	05	SI	
	650 Trail Buck			
	Left/Rear	05	SI	

<b>YAMAHA</b>				
YFM	400 FAM Kodiak	00-02	SI	
YFM	400 FWN			
	Big Bear 4WD	00-11	SI	
YFM	400 FWNH Big			
	Bear-Buckmaster			
	4WD	00-11	SI	
YFM	400 N Big Bear			
	2WD	00-11	SI	
YFM	450 FA Kodiak	03-07	SI	
YFM	450 Wolverine	06-10	SI	

**SBS 755** Recommended compound

<b>POLARIS</b>				
	250 Trail Blazer	99-07	ATS	
	250 Xplorer 4x4	00-02	ATS	
	325 Magnum 2x4,			
	4x4	00-02	ATS	
	325 Trail Boss	00-02	ATS	
	325 Xpedition	00-01	ATS	
	330 Trail Boss	03-14	ATS	
	335 Sportsman			
	4x4	99-02	ATS	
	400 Scrambler			
	2x4, 4x4	00-03	ATS	
	400 Scrambler 4x4	99-03	ATS	
	400 Sport	99-00	ATS	
	400 Sportsman	01-13	ATS	
	400 Trail Blazer	03-04	ATS	
	400 Xplorer L 4x4	00-02	ATS	
	425 Xpedition 4x4	00-03	ATS	
	455 Diesel EBS			
	4x4	99-01	ATS	
	500 Magnum 4x4	00-01	ATS	



<b>POLARIS</b>				
	500 Scrambler 2x4	01-02	ATS	
	500 Scrambler 4x4	98-13	ATS	
	500 Sportsman			
	EBS 4x4	98-02	ATS	

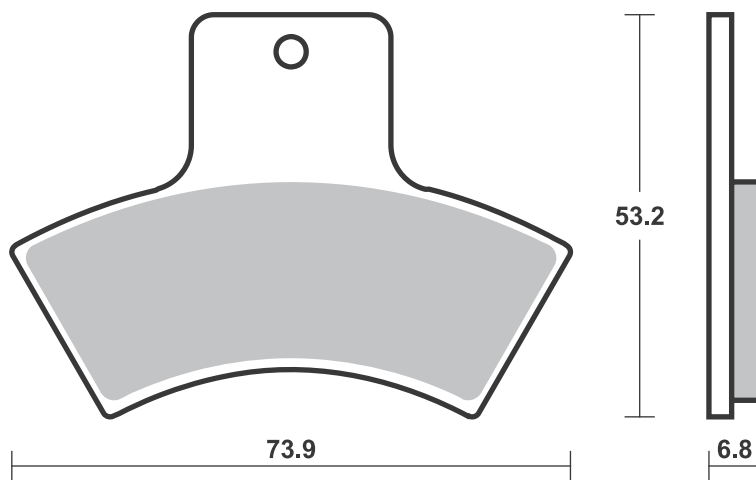
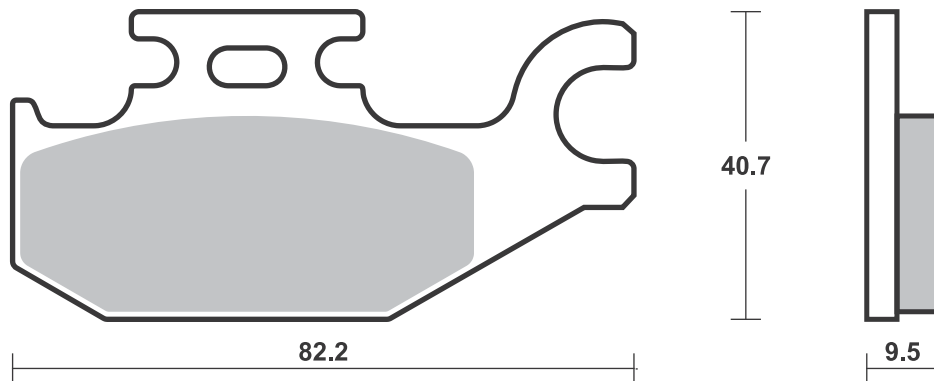
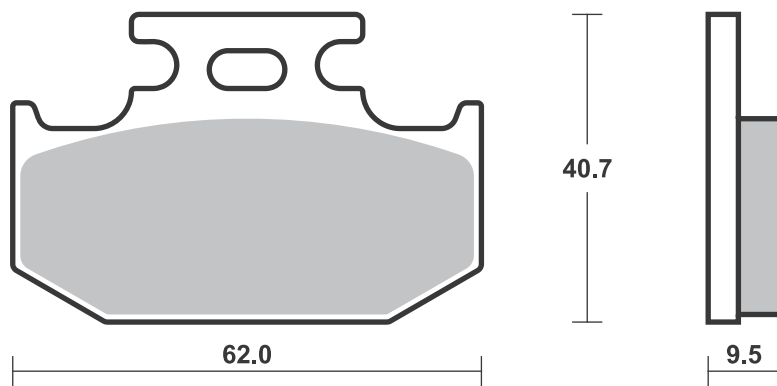





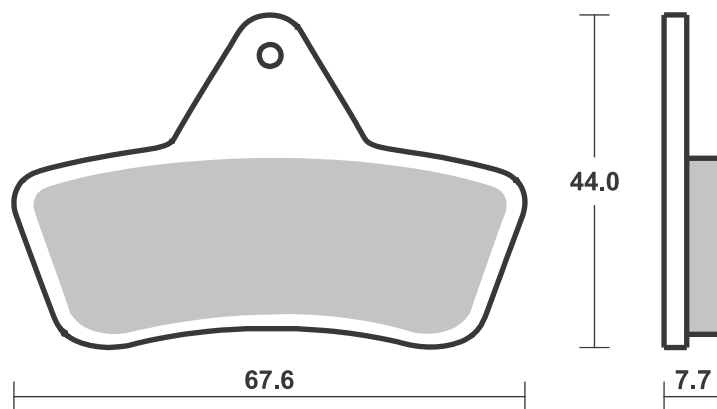
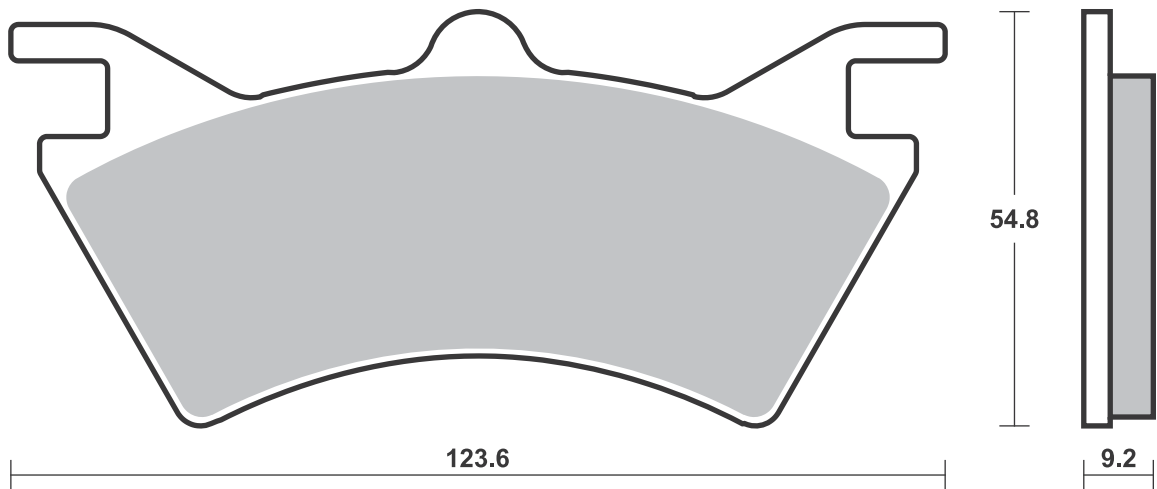
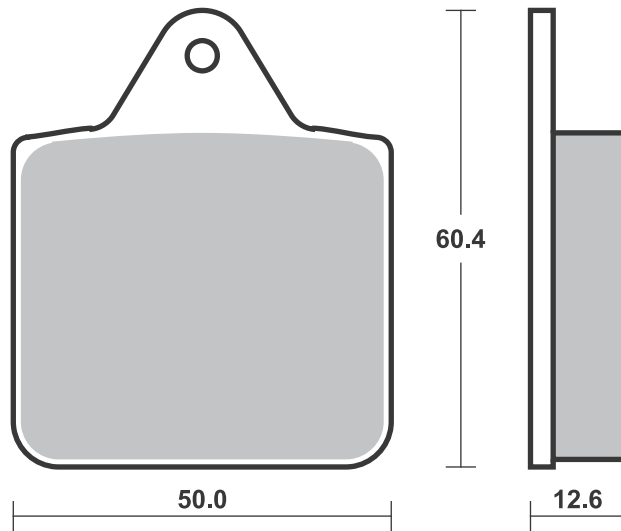



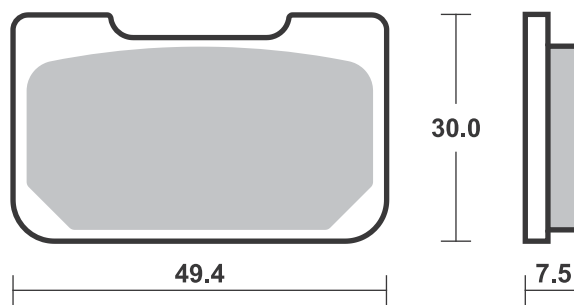

1 set = 4 pcs.

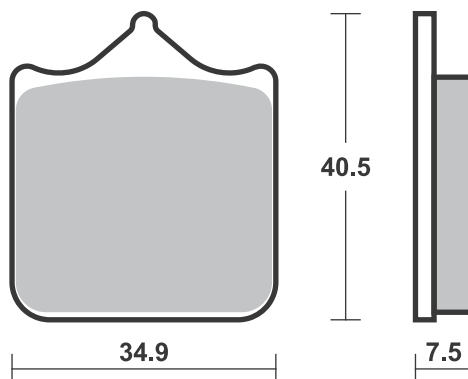

**SBS 762** Recommended compound

<b>NORTON</b>			
961	Commando		
	Cafe Racer	11-14	<b>HS</b>
961	Commando		
	SE	12-14	<b>HS</b>
961	Commando		
	SF	13-15	<b>HS</b>
<b>SHERCO</b>			
SM	450 4.5i		
	Supermotard	06	<b>RS</b>
<b>SWM</b>			
	440 Gran Milano	18-	<b>HS</b>
SM	450 R	15-17	<b>HS</b>
SM	500 R	18-	<b>HS</b>
	650 Superdual	15-18	<b>HS</b>



<b>TM</b>			
SMX	450 F	04	<b>RS</b>
SMX	660 F	04	<b>RS</b>
<b>TRIUMPH</b>			
	1050 Speed 94	15-16	<b>HS</b>
	1050 Speed Triple	08-15	<b>HS</b>

**SBS 763** Recommended compound

<b>MV AGUSTA</b>			
675	F3	11-12	<b>LS</b>
750	Brutale,		
	Brutale S	01-05	<b>LS</b>
750	F4 SPR	01-03	<b>LS</b>
750	F4/F4S	99-02	<b>LS</b>
800	F3	14-17	<b>LS</b>
910	Brutale	06-08	<b>LS</b>
910	Brutale R	06-08	<b>LS</b>
910	Brutale S	06-08	<b>LS</b>
920	Brutale	12-14	<b>LS</b>
989	Brutale R	09	<b>LS</b>
990	Brutale R	10-11	<b>LS</b>
1000	F4 LH44	18-	<b>LS</b>
1000	F4 Mamba	04-06	<b>LS</b>
1000	F4 R	06-07	<b>LS</b>
1000	F4 R	12-15	<b>LS</b>
1000	F4 RC	15-18	<b>LS</b>



<b>MV AGUSTA</b>			
1000	F4 RR	12-17	<b>LS</b>
1000	F4 Tamburini	04-06	<b>LS</b>
1000	F4S	04-06	<b>LS</b>
1078	Brutale RR	09	<b>LS</b>
1078	F4 CC	08-11	<b>LS</b>
1078	F4 RR	08-11	<b>LS</b>
1090	Brutale Corse	14-16	<b>LS</b>
1090	Brutale R	12-15	<b>LS</b>
1090	Brutale RR	10-17	<b>LS</b>

**SBS 765** Recommended compound

<b>SUZUKI</b>			
GSX-R	600	04-05	<b>LS</b>
GSF	650 Bandit /		
	S Bandit		
	Left/Rear	05	<b>LS</b>
GSX-R	750	04-05	<b>LS</b>
GSX-R	1000	03-06	<b>LS</b>
GSX-R	1000	01-02	<b>LS</b>
GSX	1400	02-07	<b>LS</b>

1 set = 4 pcs.

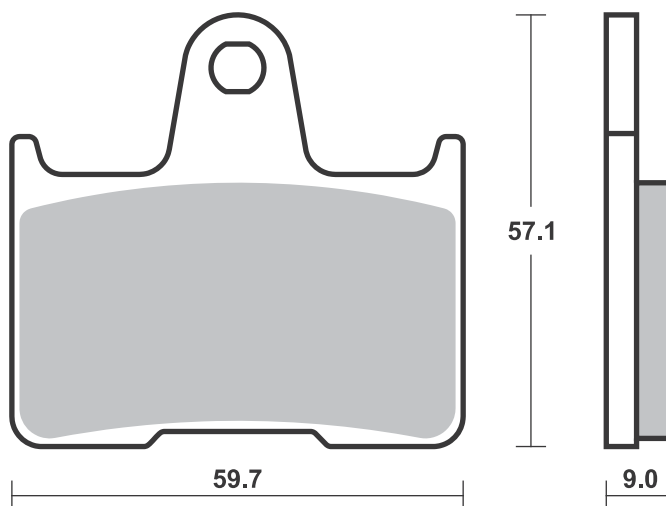
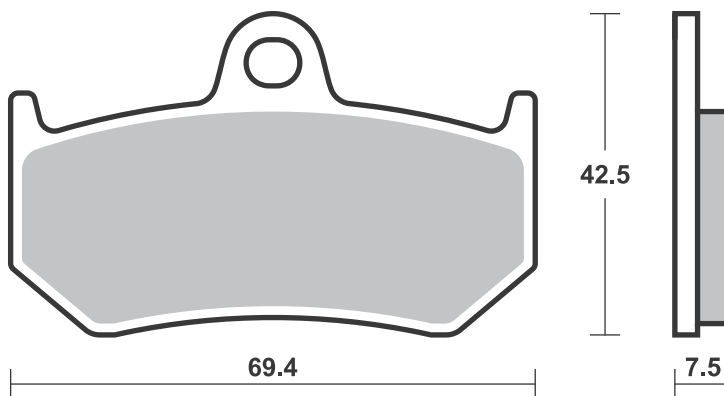
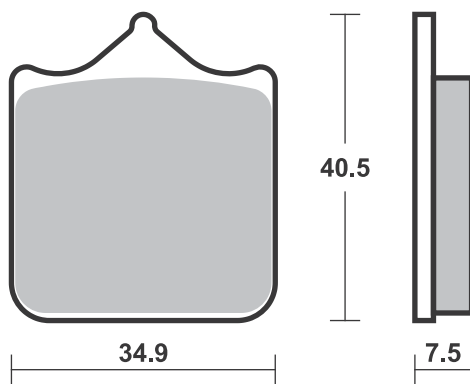



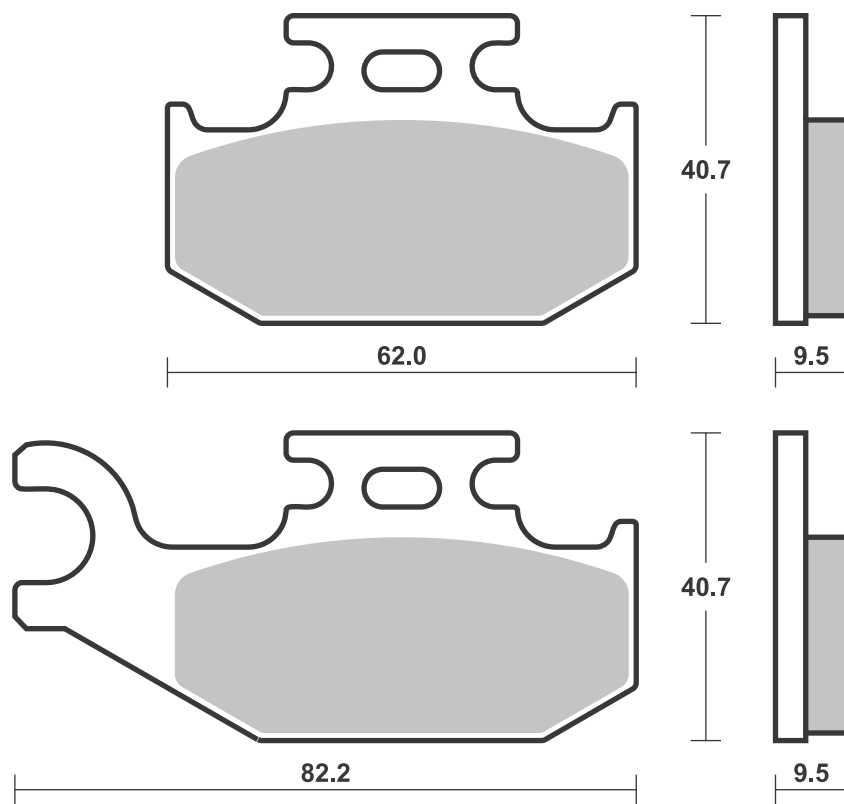
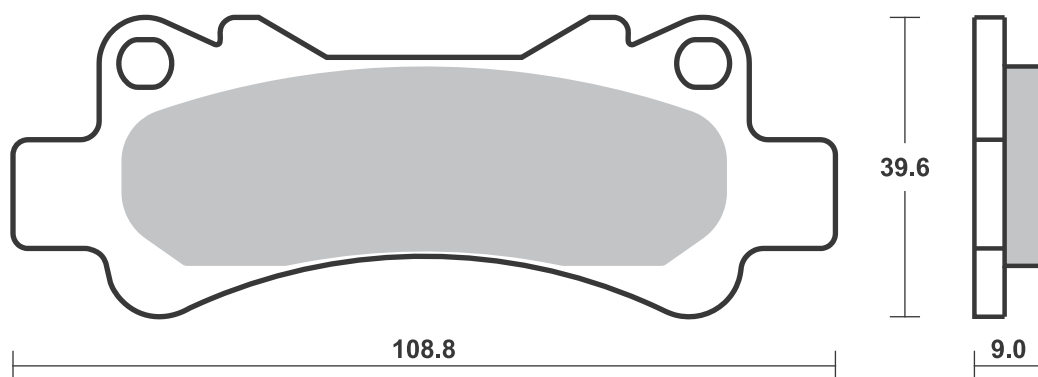





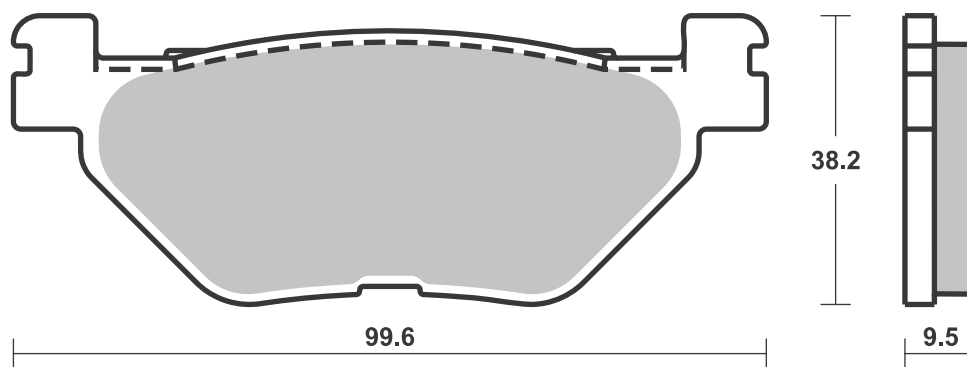
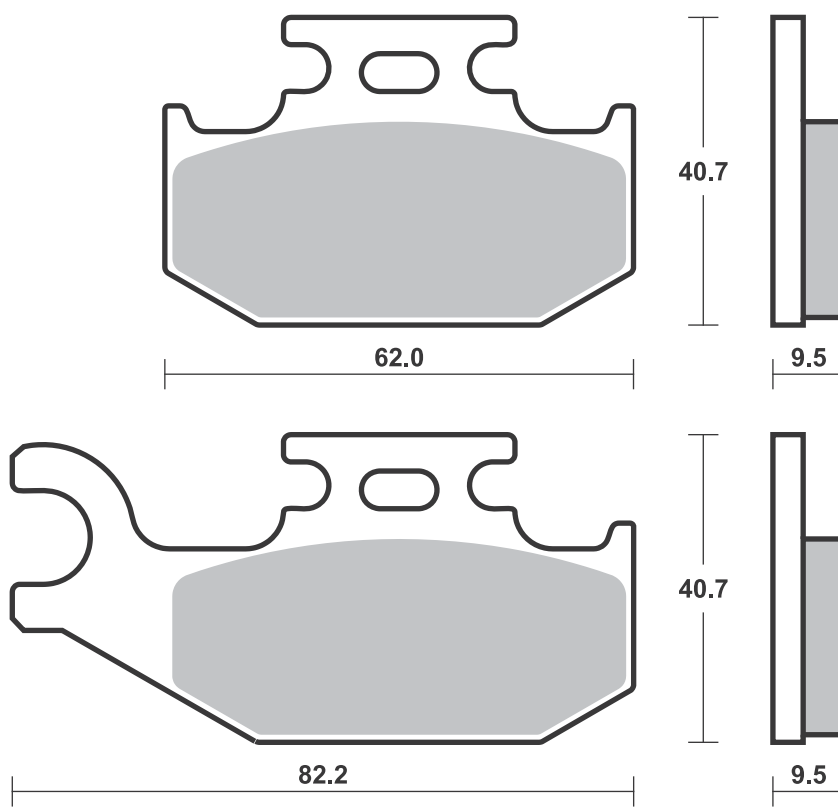



Available compounds

**HF • LS**

**SBS 770**

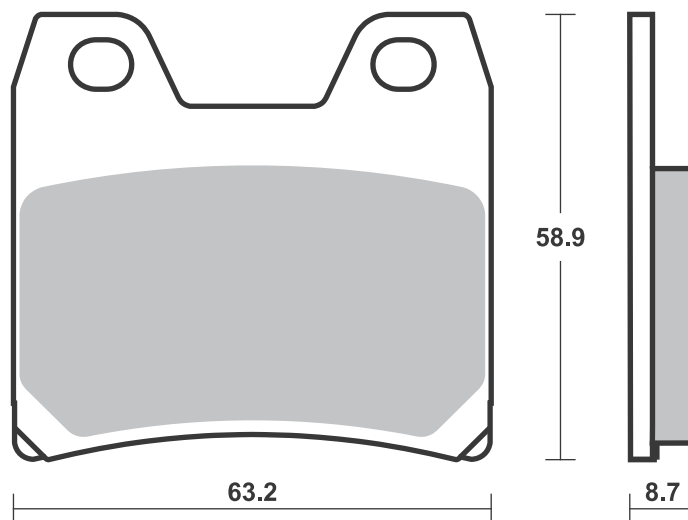

Available compounds

**HF • HS • RS • RQ**

**SBS 771**

1 set = 6 pcs.

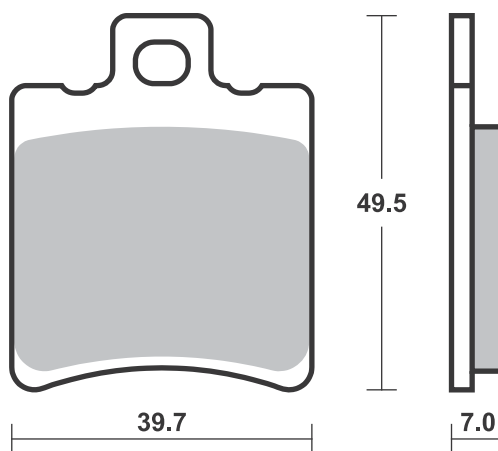

Available compounds

**HF**

**SBS 772**

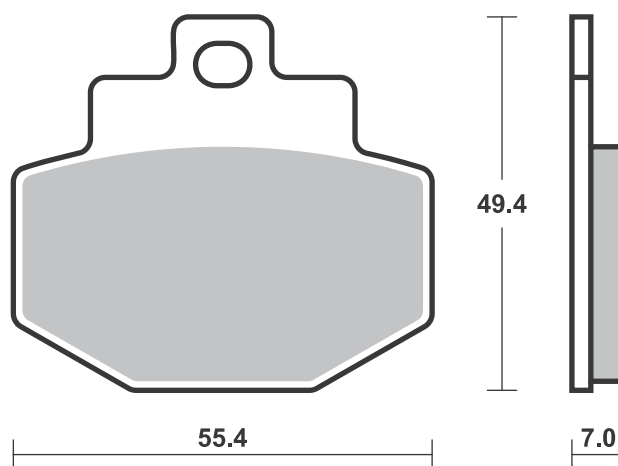



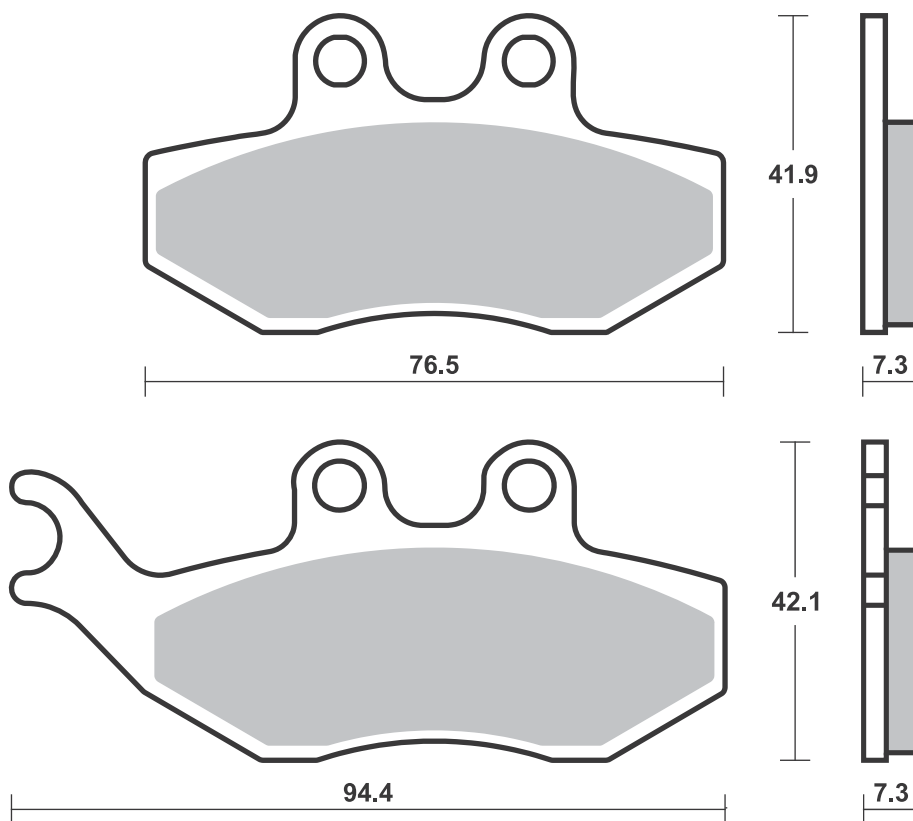
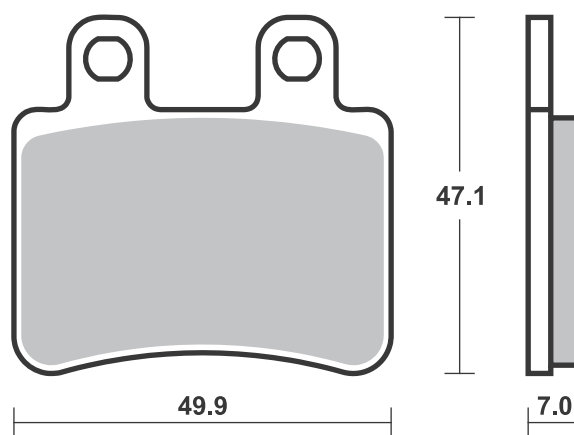



1 set = 4 pcs.

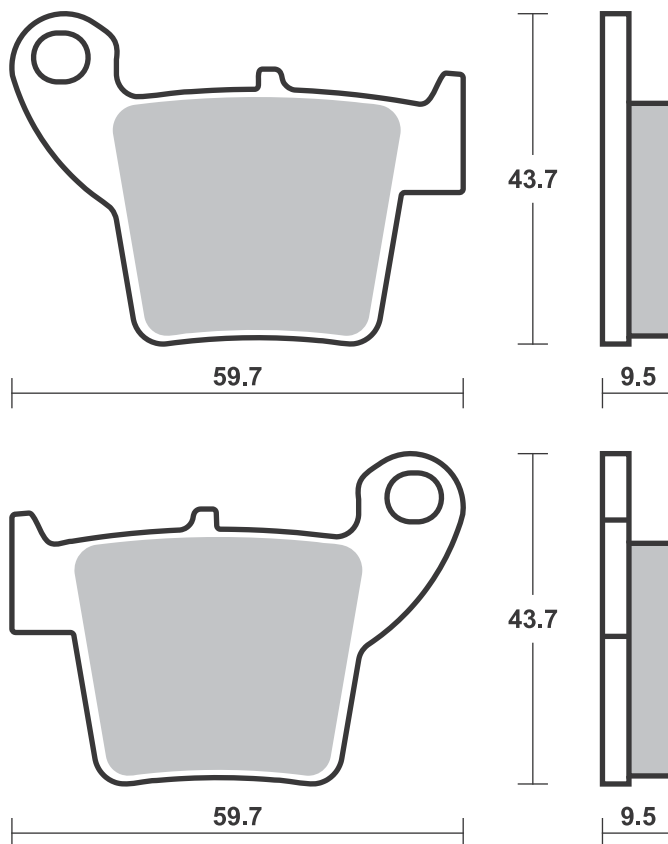
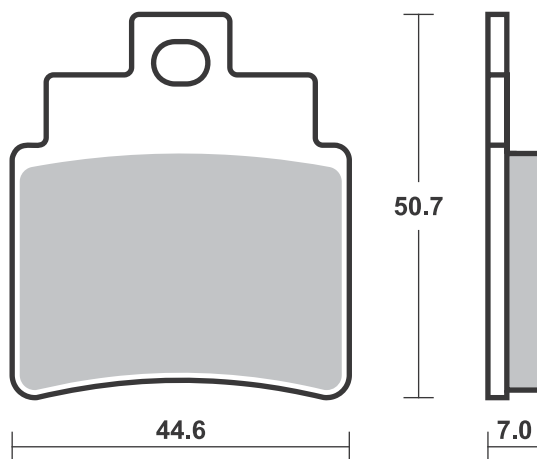





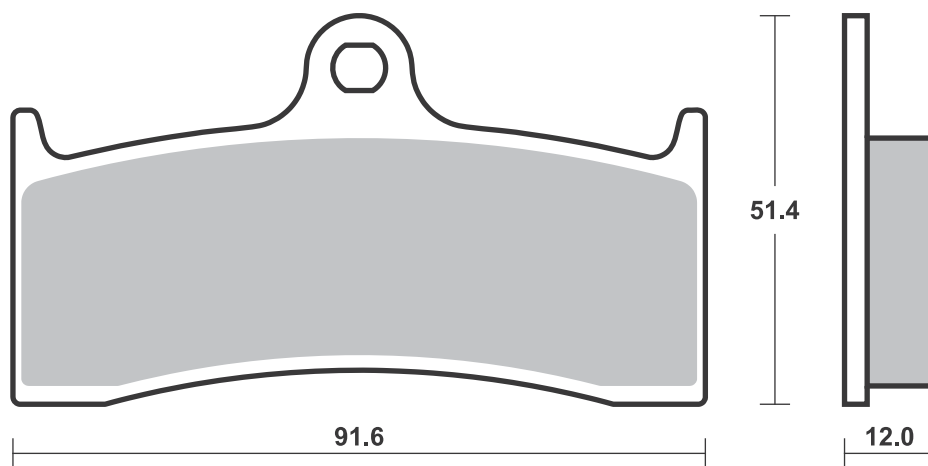
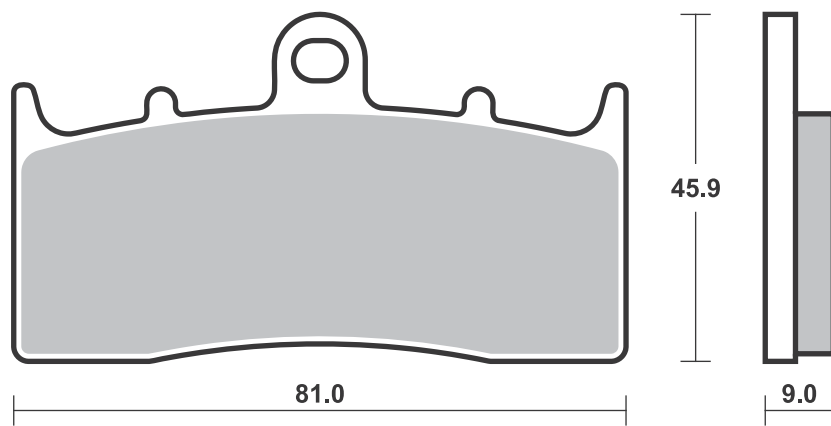



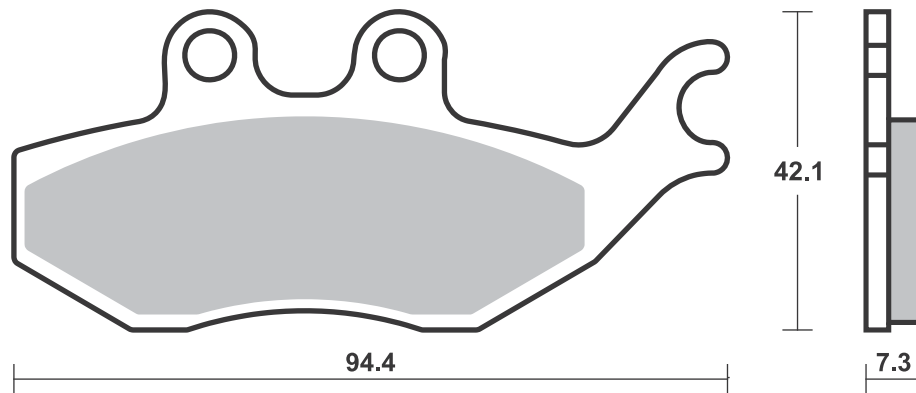
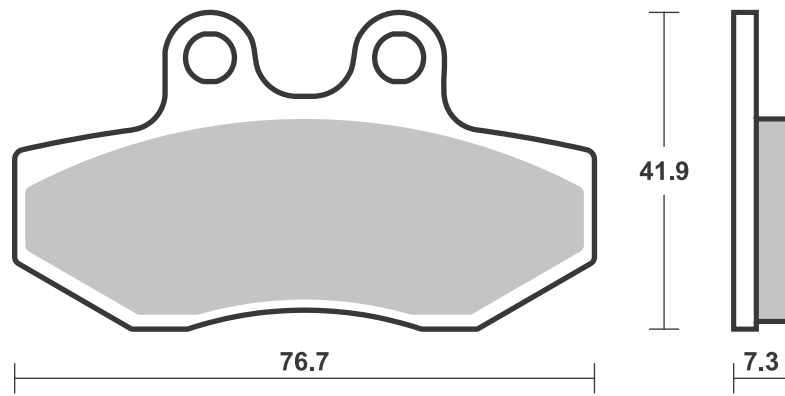

HF / HS / SP - Th. 7.0  
RS / DC - Th. 8.3

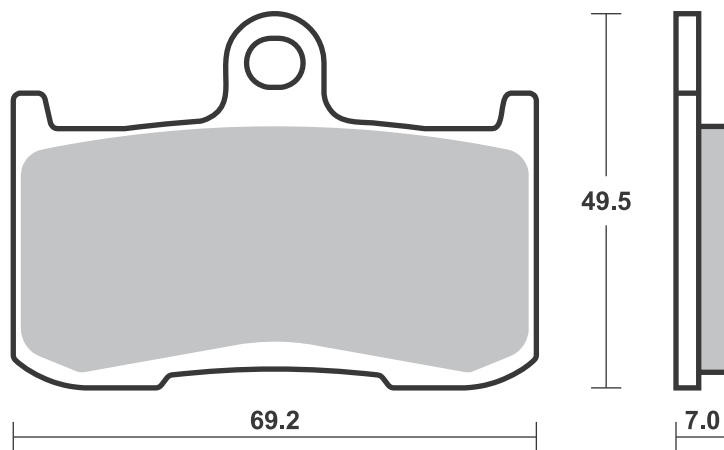



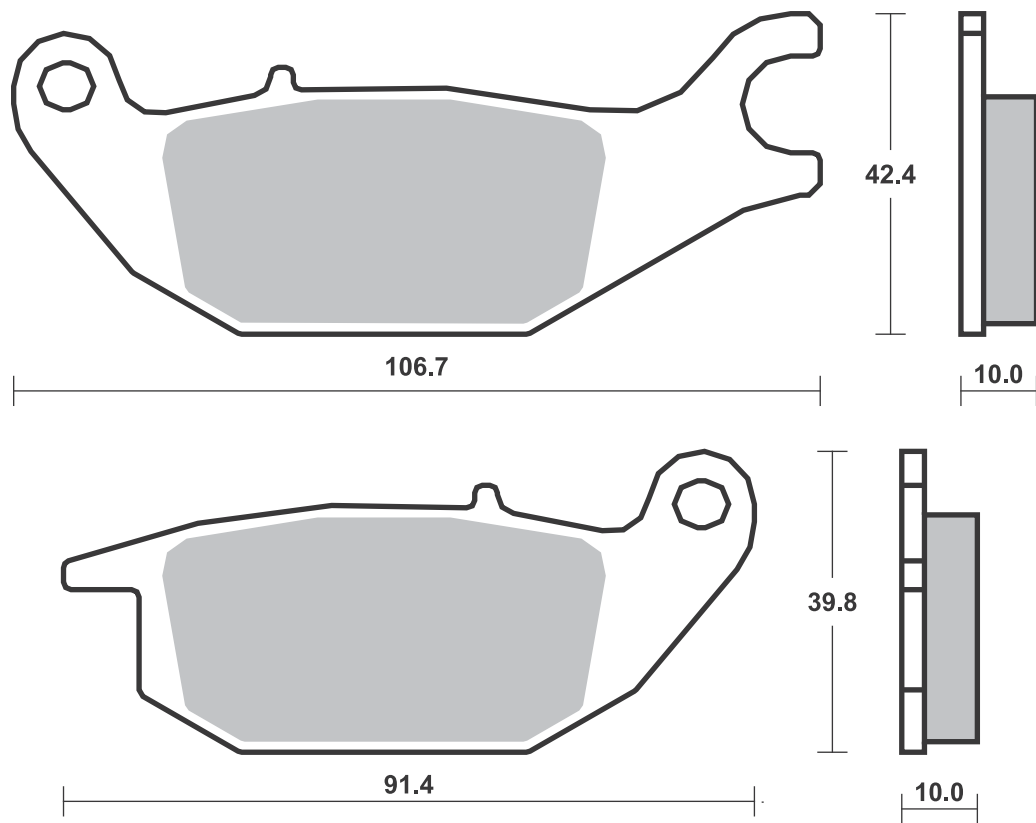
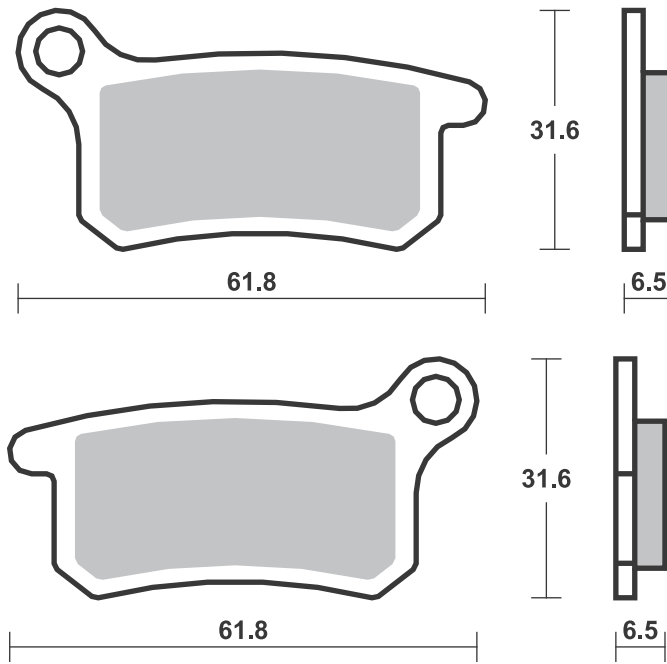

**SBS 785** Recommended compound**A.P. RACING CALIPERS**

CP-4488 Two Pad Radial

4 Piston Monoblock

**SBS 787** Recommended compound**POLARIS**

325 Xpedition	02	<b>ATS</b>
330 ATP	06-05	<b>ATS</b>
330 E Trail Blazer	08-12	<b>ATS</b>
330 Magnum		
2x4, 4x4	03-13	<b>ATS</b>
450 Sportsman	06-09	<b>ATS</b>
500 E Scrambler		
2x4, 4x4	08-11	<b>ATS</b>
500 Magnum		
2x4, 4x4	02-07	<b>ATS</b>
500 Predator e	06-13	<b>ATS</b>
500 Sportsman		
HO (to		
15.12.2008)	03-08	<b>ATS</b>
600 Sportsman	03-06	<b>ATS</b>
700 Sportsman	02-09	<b>ATS</b>

**POLARIS**

700 Sportsman		
MV 700	05-06	<b>ATS</b>
800 Sportsman		
(to		
15.12.2008)	05-08	<b>ATS</b>

**SBS 788** Recommended compound**DERBI**

659 Mulhacen	05	<b>HS</b>
--------------	----	-----------

<b>KAWASAKI</b>		
ZX-6RR	600 Ninja	03-06 <b>HS</b>
ZX-6R	636 Ninja	03-06 <b>HS</b>
ZX-10R	1000 Ninja	04-07 <b>HS</b>
ZX-12R	1200 Ninja	04-06 <b>HS</b>
VN	1600 Mean	
	Streak	05 <b>HS</b>

  

<b>SUZUKI</b>		
GSX-R	1000	03 <b>HS</b>
M95	1600 Boulevard	05-07 <b>HS</b>

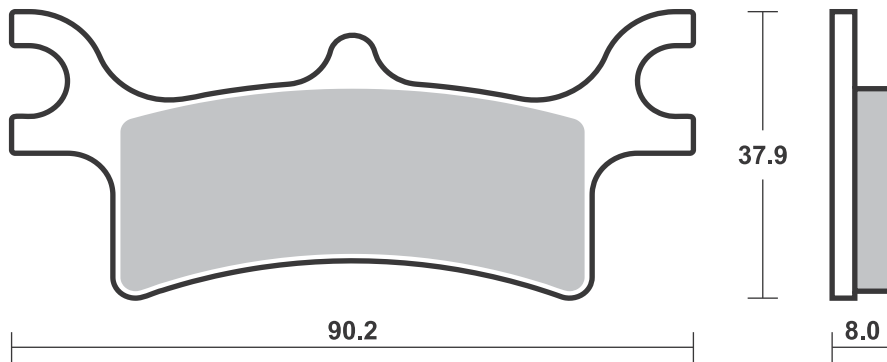
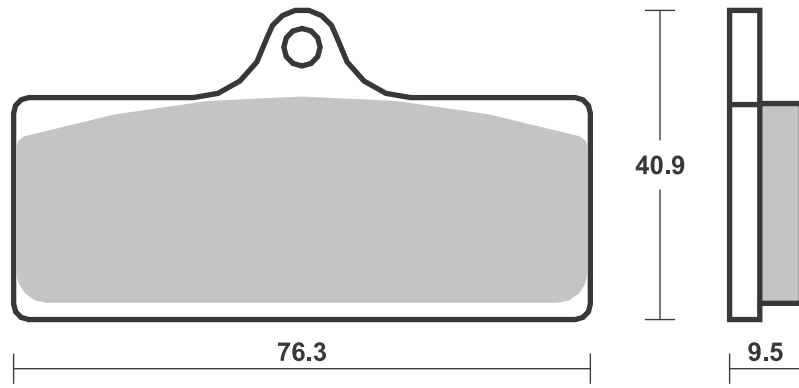

1 set = 4 pcs.

HS / SP - Th. 7.9  
RS / DC / DS - Th. 9.5

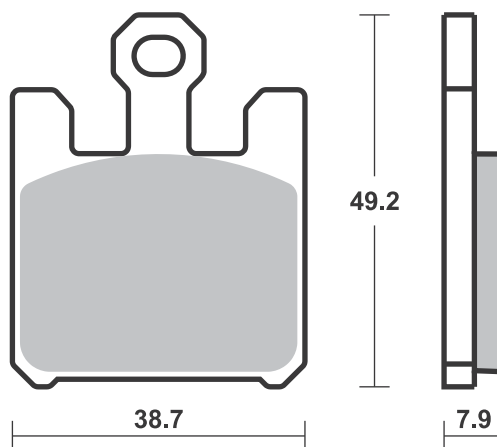





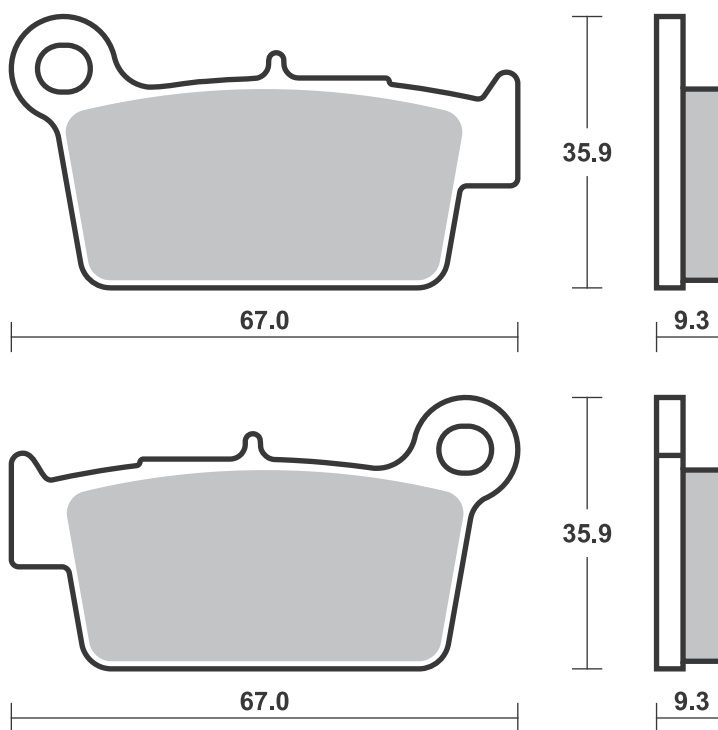
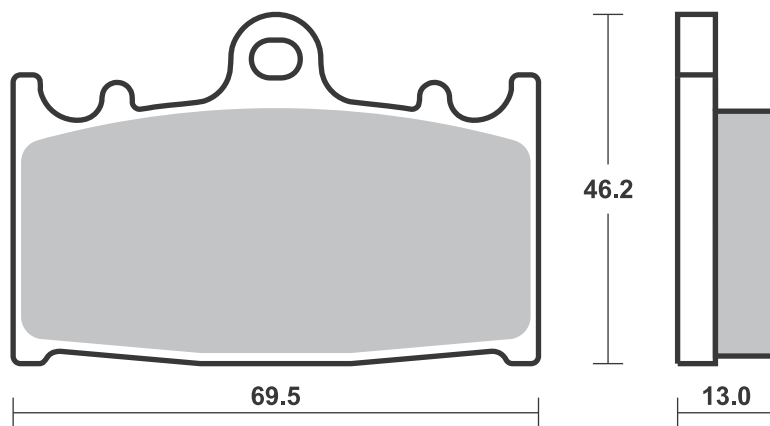



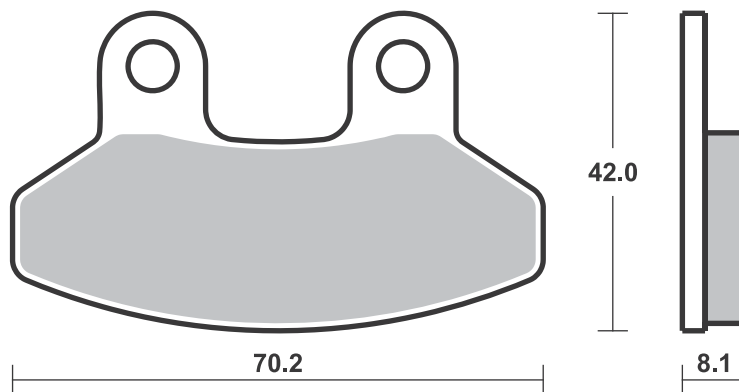
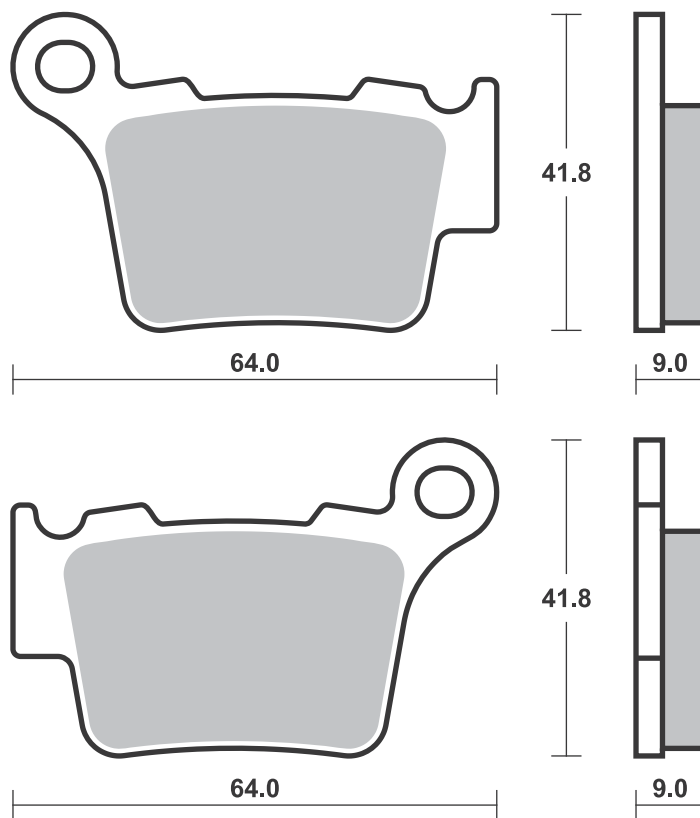

**SBS 794** Recommended compound



<b>COBRA</b>				
CX	50 Big Wheel	10-14	RSI	RSI
CX	50 Junior	07-10	RSI	
CX	50 Junior	11-13	RSI	RSI
CX	50 Senior	07-13	RSI	RSI
<b>HUSQVARNA</b>				
CR	50 Pro Senior	06		RSI
CR	50 Senior	06		RSI
SM	50	10-12		RSI
TC	50	17-18	RSI	RSI
<b>KTM</b>				
SM	50 Supermoto	06	RSI	RSI
SX	50	09-18	RSI	RSI
SX	50 Mini	09-18	RSI	RSI
SX	50 Pro Junior			
	LC	02-05	RSI	



<b>KTM</b>				
SX	50 Pro Senior			
	LC	02-03	RSI	
SX	50 Pro Senior			
	LC	04-09	RSI	RSI
SX	50 Senior			
	Adventure	04-07	RSI	
SX	65	04-08		RSI
<b>LEM</b>				
	50 CX2, CX3,			
	RX2, RX3	03-06	RSI	RSI
	50 R2, R3,			
	R3 XC	03-06	RSI	RSI
RX	65	05-10	RSI	RSI
RX	150	11		RSI



<b>POLINI</b>				
X1	50 R	04-06	RSI	RSI
X3	50 R	04-06	RSI	RSI
X5	65 RP	05-06	RSI	RSI

**SBS 795** Recommended compound



<b>BUELL</b>				
XB9R	984 Firebolt	02-10	HS	
XB9S	984 Lightning	03-10	HS	
XB9SX	984 CityX	05-10	HS	
XB12R	1200 Firebolt	04-08	HS	
XB12S	1200 Lightning	04-08	HS	
XB12Scg	1200 Lightning	06-08	HS	
XB12Ss	1200 Lightning			
	Long	06-08	HS	
XB12STT	1200 Super TT	07-10	HS	
XB12X	1200 Ulysses	06-10	HS	

**SBS 796** Recommended compound



<b>BMW</b>				
R	850 RT With			
	Integral			
	ABS	01-06	HS	
R	1100 S Without			
	Integral			
	ABS	01-05	HS	
R	1150 GS			
	Adventurer			
	(Tokico cal.)	02-05	HS	
R	1150 RT With			
	Integral			
	ABS	01-06	HS	
	1200 HP2			
	Megamoto	06-08	HS	



<b>BMW</b>				
K	1200 GT (K41)			
	With			
	Integral			
	ABS	02-05	HS	
K	1200 GT (K44)			
	With			
	Integral			
	ABS	04-08	HS	
K	1200 RS	01-05	HS	
K	1200 S	05-08	HS	
R	1200 GS	04-12	HS	
R	1200 GS			
	Adventure	08-13	SP	
R	1200 GS Tripple			
	Black	11-16	SP	
R	1200 RT	06-13	HS	
R	1200 S	06-07	HS	



<b>BMW</b>				
R	1200 ST	06-07	HS	
K	1300 GT	09-10	HS	
K	1300 S	09-15	HS	

Brake Pad 1:1 Drawings, Compounds, Fitments

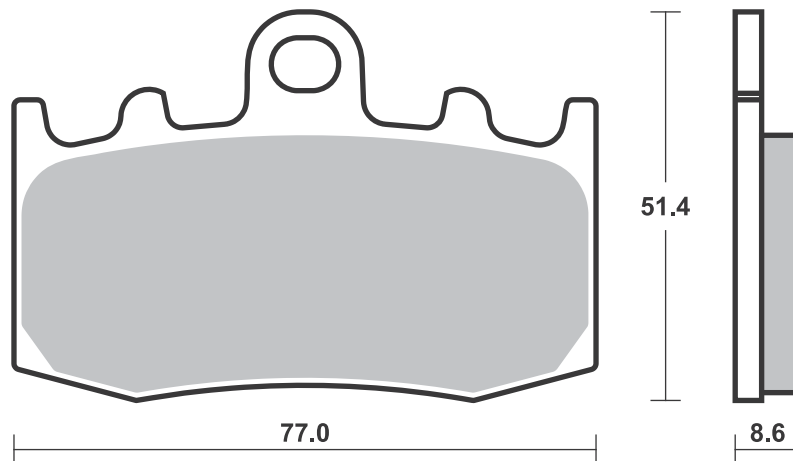
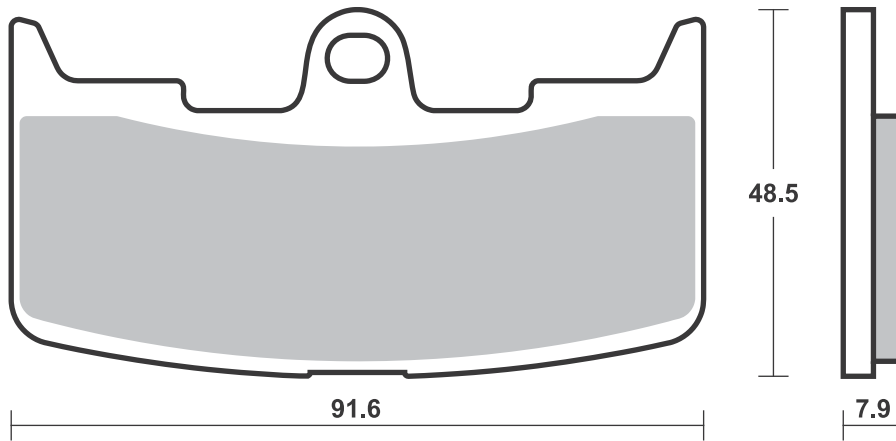
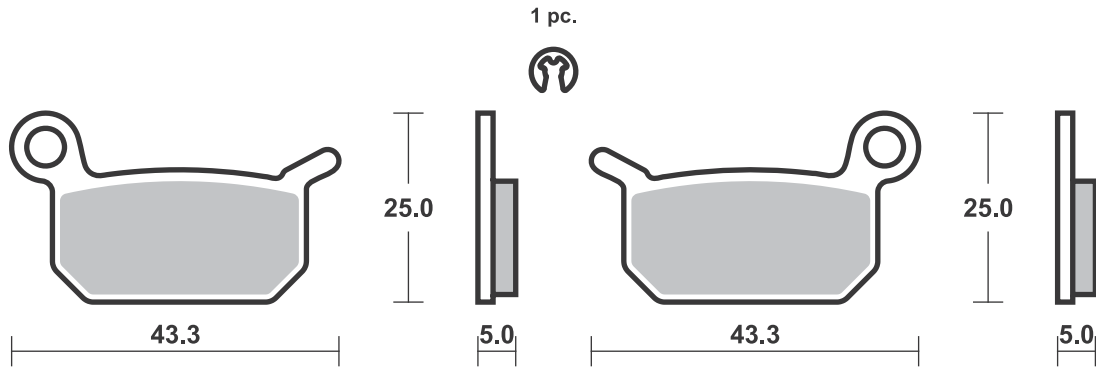



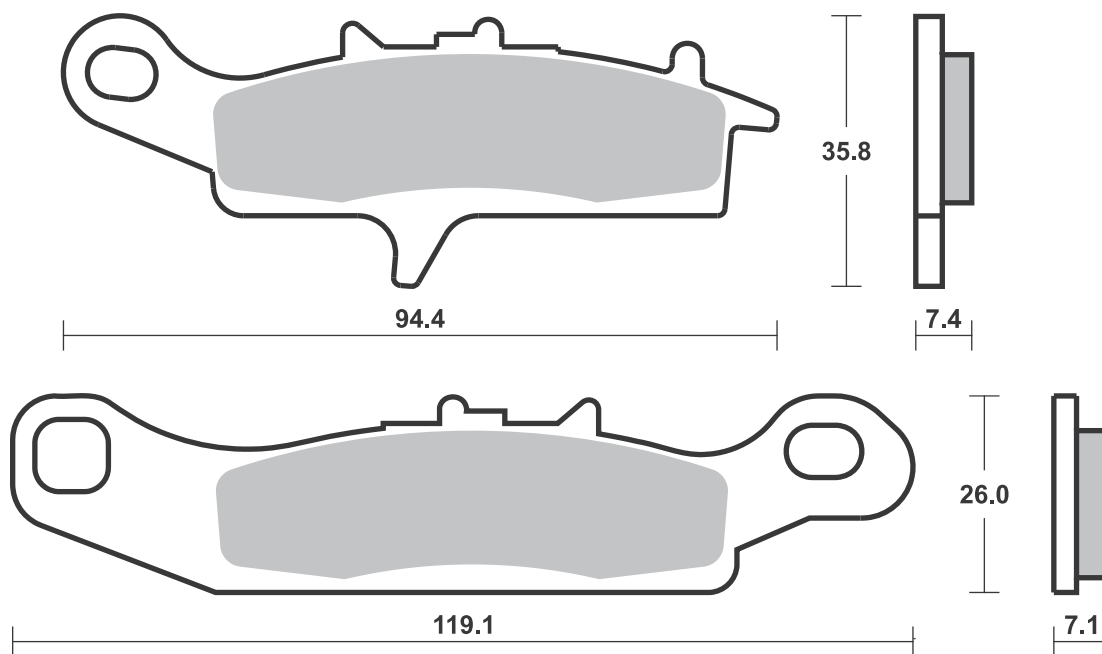
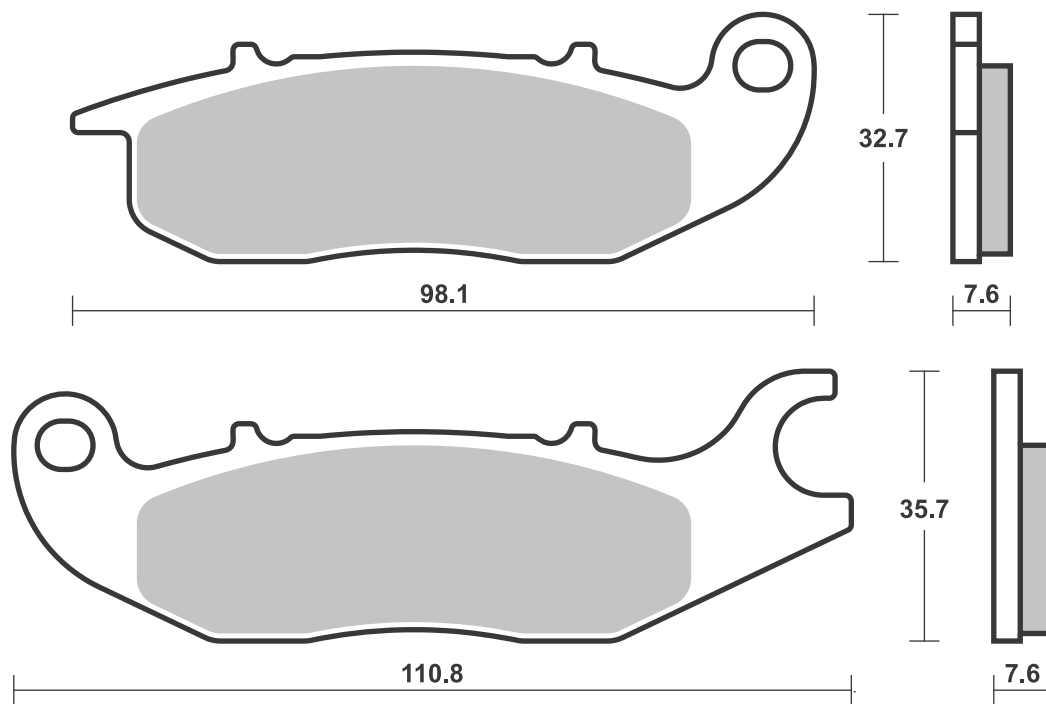

**SBS 799 Recommended compound**



<b>CF MOTO</b>			
	450 C-Force L	16-17	<b>SI</b>
	450 G-Force L	16-17	<b>SI</b>
CF	500 Terralander	13-15	<b>SI</b>
	550 C-Force	16-17	<b>SI</b>
CF	625 Terralander	11-15	<b>SI</b>
CF	800 Terralander	12-14	<b>SI</b>
<b>GOES</b>			
	520 Max	07-12	<b>SI</b>
G	520	07-12	<b>SI</b>
G	525	12-14	<b>SI</b>
G	620	11-14	<b>SI</b>
G	625 A	12-14	<b>SI</b>



<b>YAMAHA</b>			
YFM	660 FWAP 4x4		
	Grizzly	02-08	<b>SI</b>

**SBS 800 Recommended compound**



<b>POLARIS</b>			
	EV-LSV	10-11	<b>ATS</b>
	LSV 4x4	11-12	<b>ATS</b>
	Ranger 48v		
	EV	13-18	<b>ATS</b>
	500 Ranger 2x4	08-07	<b>ATS</b>
	500 Ranger 2x4		
	EFI	08-13	<b>ATS</b>
	500 Ranger 2x4,		
	4x4, 6x6	02-13	<b>ATS ATS</b>
	500 Ranger 4x4	12-13	<b>ATS</b>
	500 Ranger XP	06-09	<b>ATS ATS</b>
	700 Ranger 4x4		
	EFI	08	<b>ATS</b>
	700 Ranger 6x6		
	EFI	12-13	<b>ATS</b>



<b>POLARIS</b>			
	800 Ranger		
	RZR4 EFI	12-14	<b>ATS</b>
	800 Ranger XP	12-13	<b>ATS</b>
	800 RZR-4	10-14	<b>ATS</b>

**SBS 801 Recommended compound**



<b>KAWASAKI</b>			
KFX	450 Left/Rear	07-15	<b>SI</b>
KVF	650 Brute Force		
	4x4 Left	05-11	<b>SI</b>
KVF	650 Prairie Left	01-03	<b>SI</b>
KFX	700 V-Force Left	04-13	<b>SI</b>
KSV	700 V-Force Left	04-11	<b>SI</b>
KVF	700 Prairie Left	04-13	<b>SI</b>
<b>SUZUKI</b>			
LT-V	700 Quadrunner		
	Twin Peaks		
	Left	04-06	<b>SI</b>

Brake Pad 1:1 Drawings, Compounds, Fitments



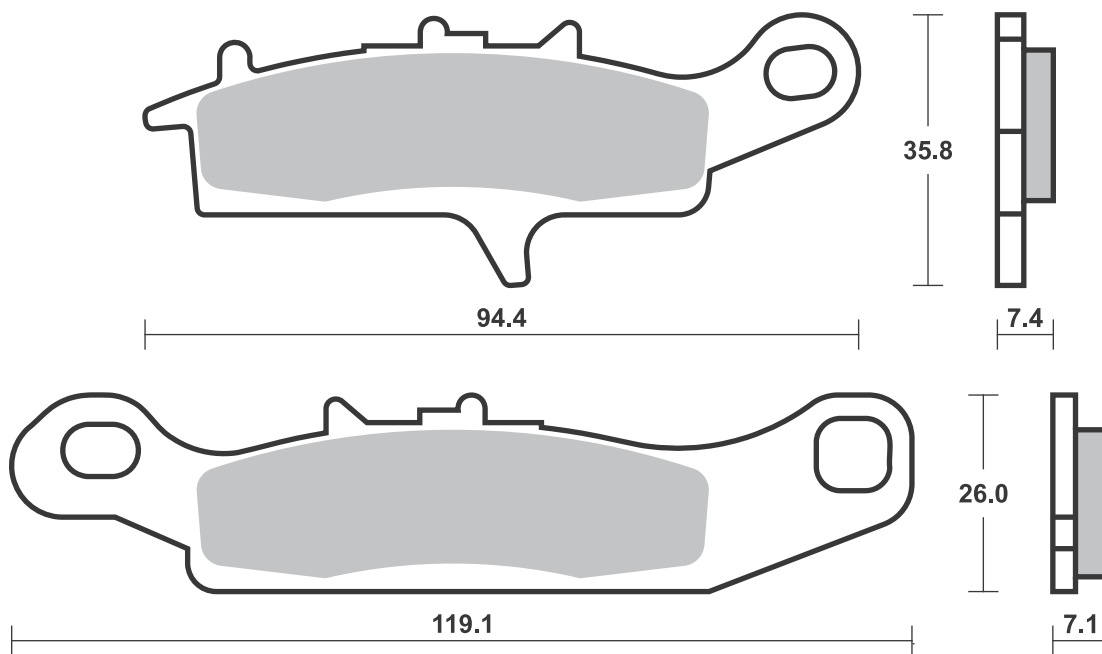
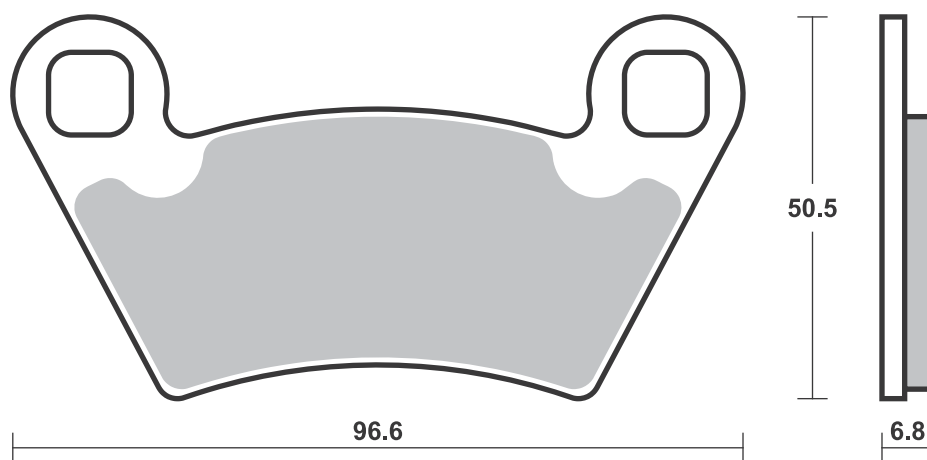
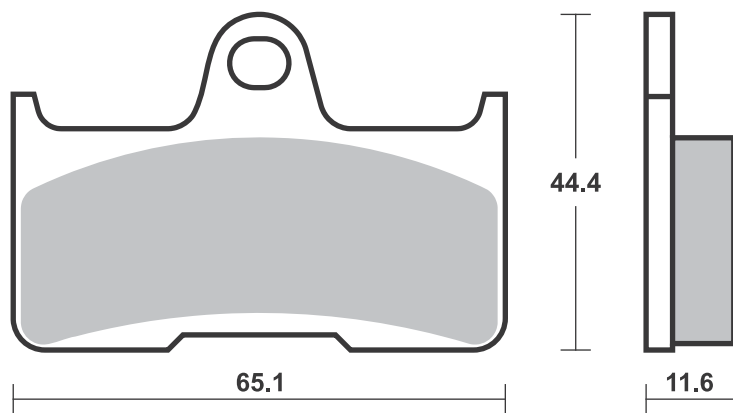







## SBS 802 Recommended compound

																							
<b>BETA</b>								<b>GAS GAS</b>						<b>SCORPA</b>									
	80 EVO	09-10	RSI					TXT	300 Pro	07-11	RSI			SY	250 Trial	00-01	RSI						
	80 Rev	08-10	RSI												300 Twenty Trial	16-18	RSI						
	125 EVO	09-14	RSI					<b>HONDA</b>						<b>SHERCO</b>									
	125 Rev 3	00-05	RSI	RSI										ST	125 1.25	06-11	RSI						
	125 Rev 3	06-08	RSI						250 Cota 4RT	04-16	RSI			ST	250 2.5	01	RSI						
	200 EVO	09-14	RSI						Cota	260 4RT	04-16	RSI		ST	290 2.9	01	RSI						
	200 Rev 3	06-08	RSI					<b>MONTESA</b>						ST	300	16-18	RSI						
	250 4-T Rev 3	07-11	RSI						250 Cota 4RT	04-16	RSI			ST	320 3.2F	05	RSI						
	250 EVO								Cota	260 4RT	04-16	RSI		<b>TRS</b>									
	(2-T / 4-T)	09-14	RSI						360 315R	01-04	RSI												
	250 Rev 3	00-04	RSI	RSI				<b>OSSA</b>															
	250 Rev 3	05-09	RSI						TR	125 i	15	RSI			250 ONE	16-18	RSI						
	270 Rev 3	00-04	RSI	RSI					TR	250 i	15	RSI			280 ONE	16-18	RSI						
	270 Rev 3	05-08	RSI						TR	280 i	10-15	RSI			300 ONE	16-18	RSI						
	290 EVO	09-13	RSI						TR	280 i Explorer	12-15	RSI											
	300 EVO	09-15	RSI						TR	300 i	15	RSI											
<b>GAS GAS</b>								<b>SCORPA</b>															
TX	125 Randone	12-13	RSI						SY	115 F Trial	06	RSI											
TXT	125	04-13	RSI							125 Twenty Trial	16-18	RSI											
TXT	200	04-10	RSI						SY	125 F Trial	06-11	RSI											
TXT	250	04-07	RSI							250 Twenty Trial	16-18	RSI											
TXT	280	04	RSI						SY	250 F Trial	06-11	RSI											
TXT	300	04-06	RSI																				

## SBS 803 Recommended compound

																							
<b>APRILIA</b>								<b>HUSQVARNA</b>						<b>SCORPA</b>									
	50 Mini RX	04	RSI					CR	50 Junior	06	RSI			SY	250 F Trial	06-11	RSI						
<b>BETA</b>								CR	50 Pro Senior	06	RSI			SY	250 Trial	00-01	RSI						
	50 ProRace							CR	50 Senior	06	RSI				300 Twenty Trial	16-18	RSI						
	12/10	04	RSI	RSI				SM	50	10-12	HF			<b>SHERCO</b>									
<b>GAS GAS</b>								<b>JOTAGAS</b>						ST	80 (Formula cal.)	13-14	RSI						
TX	125 Randone	12-13	RSI					JT	125	14-18	RSI			ST	125 (Formula cal.)	13-14	RSI						
TXT	125 (Formula cal.)	12-13	RSI					JT	250	14-18	RSI			ST	125 1.25	06-11	RSI						
TXT	125	04-13	RSI					JT	280	14-18	RSI			ST	250 (Formula cal.)	13-14	RSI						
TXT	125 Pro Racing	14	RSI					JT	300	14-18	RSI			ST	250 2.5	01	RSI						
TXT	125 Pro Replica	13	RSI					<b>MONTESA</b>						ST	290 (Formula cal.)	13-14	RSI						
TXT	200	04-10	RSI						250 Cota 4RT	04-16	RSI			ST	290 2.9	01	RSI						
TXT	250 (Formula cal.)	12-13	RSI						Cota	260 4Ride	16-18	RSI		ST	300	16-18	RSI						
TXT	250	04-07	RSI						Cota	260 4RT	04-16	RSI		ST	305 (Formula cal.)	13-14	RSI						
TXT	250 Pro Racing	14-18	RSI						Cota	260 4RT Race				ST	320 3.2F	05	RSI						
TXT	250 Pro Replica	13-14	RSI							Replica	15-18	RSI		<b>TRS</b>									
TXT	280 (Formula cal.)	12	RSI						Cota	300 RR	16-18	RSI											
TXT	280	04	RSI							360 315R	01-04	RSI			250 ONE	16-18	RSI						
TXT	280 Pro Racing	14-18	RSI						<b>OSSA</b>						280 ONE	16-18	RSI						
TXT	280 Pro Replica	13	RSI												300 ONE	16-18	RSI						
TXT	300 (Formula cal.)	12	RSI						TR	125 i	15	RSI		<b>VERTIGO</b>									
TXT	300	04-06	RSI						TR	250 i	15	RSI			300 Combat								
TXT	300 Pro	07-11	RSI						TR	280 i	10-15	RSI			Camo Works	15-18	RSI						
TXT	300 Pro Racing	14-18	RSI						TR	280 i Explorer	12-15	RSI			300 Combat								
TXT	300 Pro Replica	13	RSI						TR	300 Factory R	15	RSI			Ice Hell	15-18	RSI						
									TR	300 i	15	RSI			300 Combat RR	15-18	RSI						
<b>HONDA</b>								<b>SCORPA</b>															
	250 Cota 4RT	04-16	RSI						SY	115 F Trial	06	RSI											
Cota	260 4Ride	16-18	RSI						TY-S	115 F Trial	06	RSI											
Cota	260 4RT	04-16	RSI							125 Twenty Trial	16-18	RSI											
Cota	260 4RT Race								SY	125 F Trial	06-11	RSI											
	Replica	15-18	RSI						TY-S	125 F Trial	06-08	RSI											
Cota	300 RR	16-18	RSI							250 Twenty Trial	16-18	RSI											

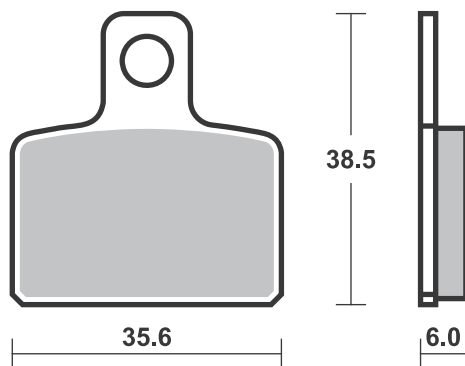
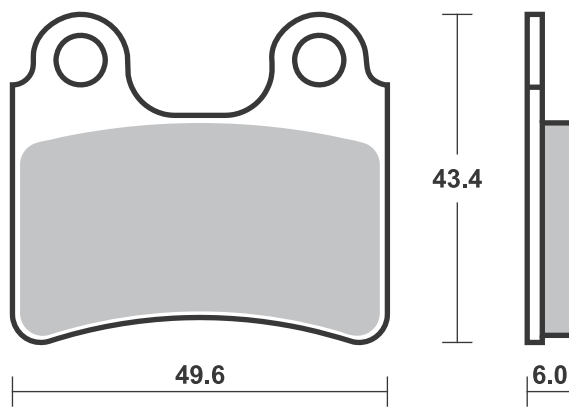



1 set = 4 pcs.

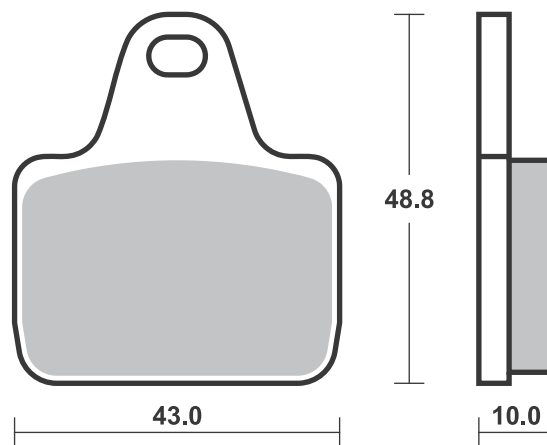

HS / SP - Th. 8.0  
RS / DC / DS - Th. 9.0

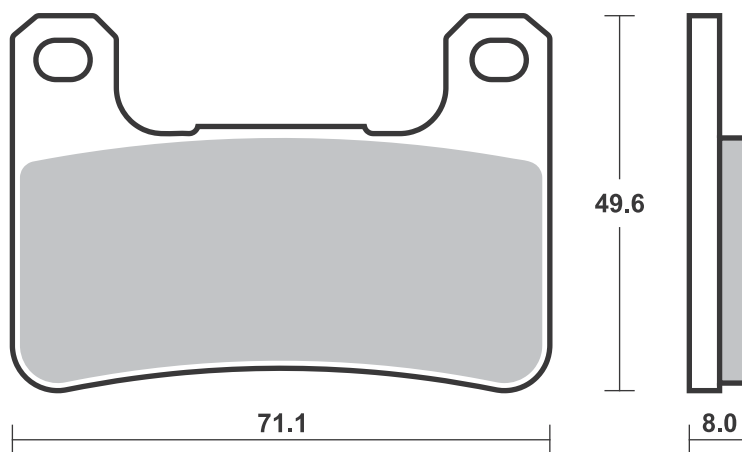



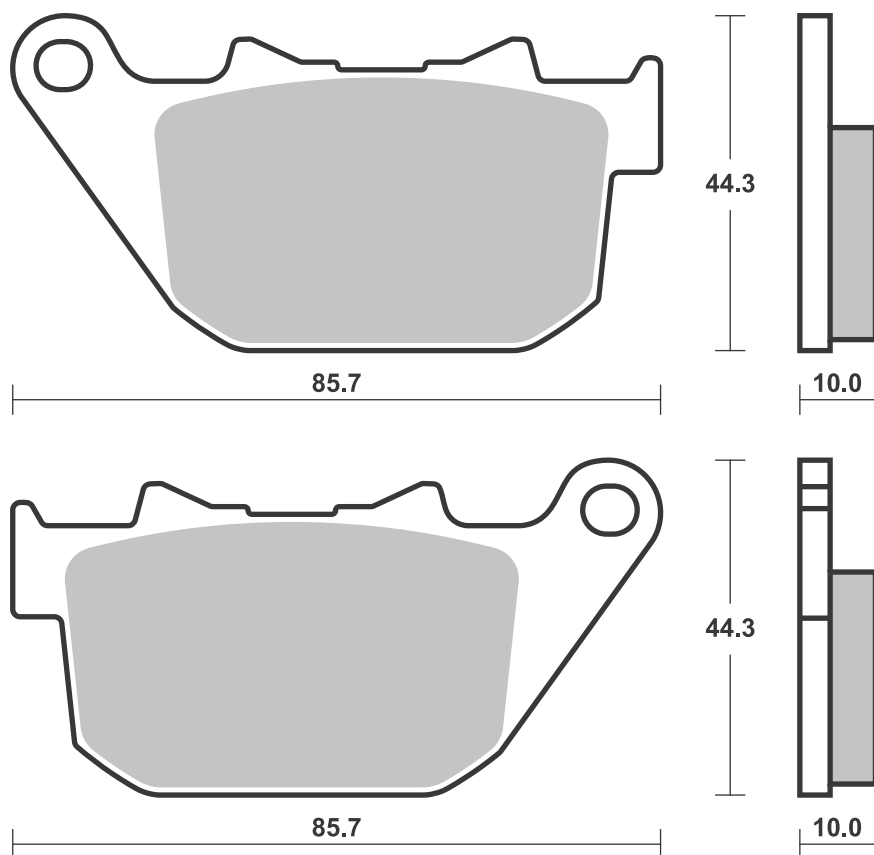
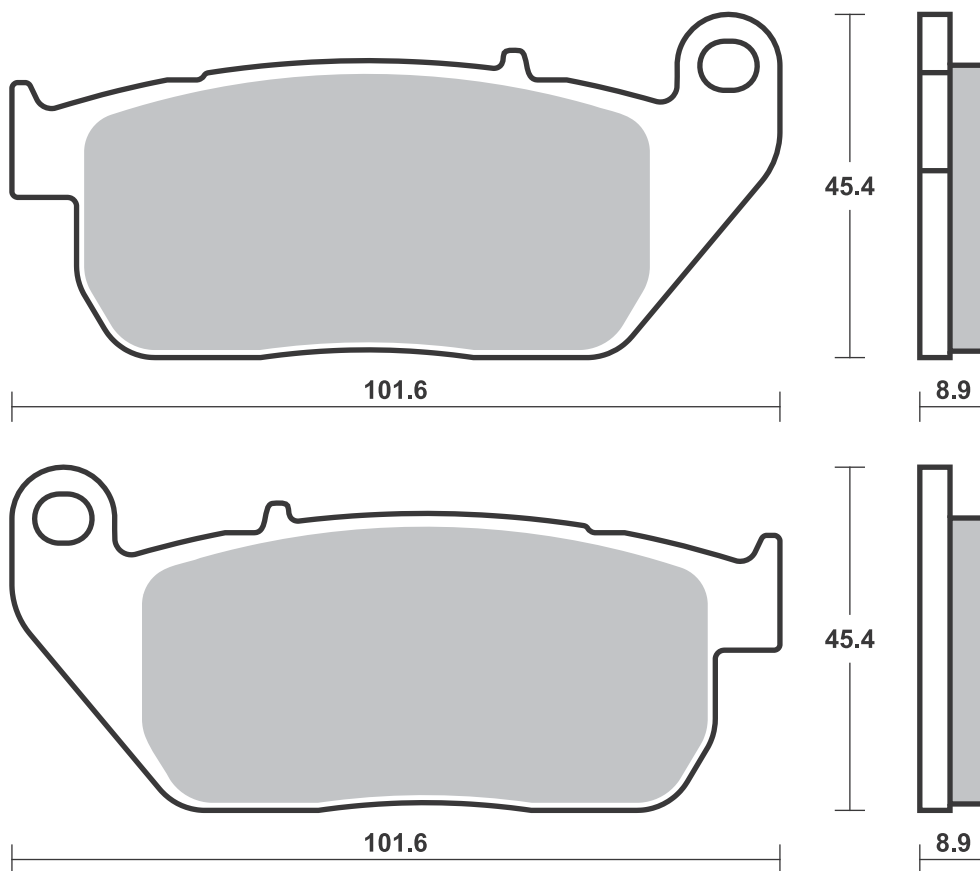





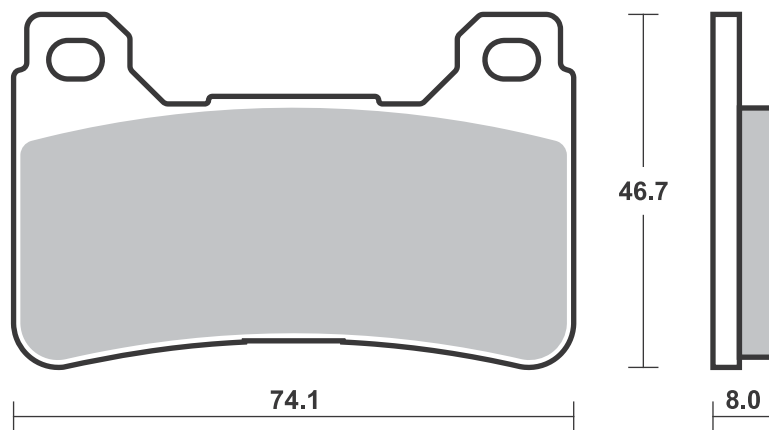

HS / SP - Th. 8.0  
RS / DC / DS - Th. 9.0

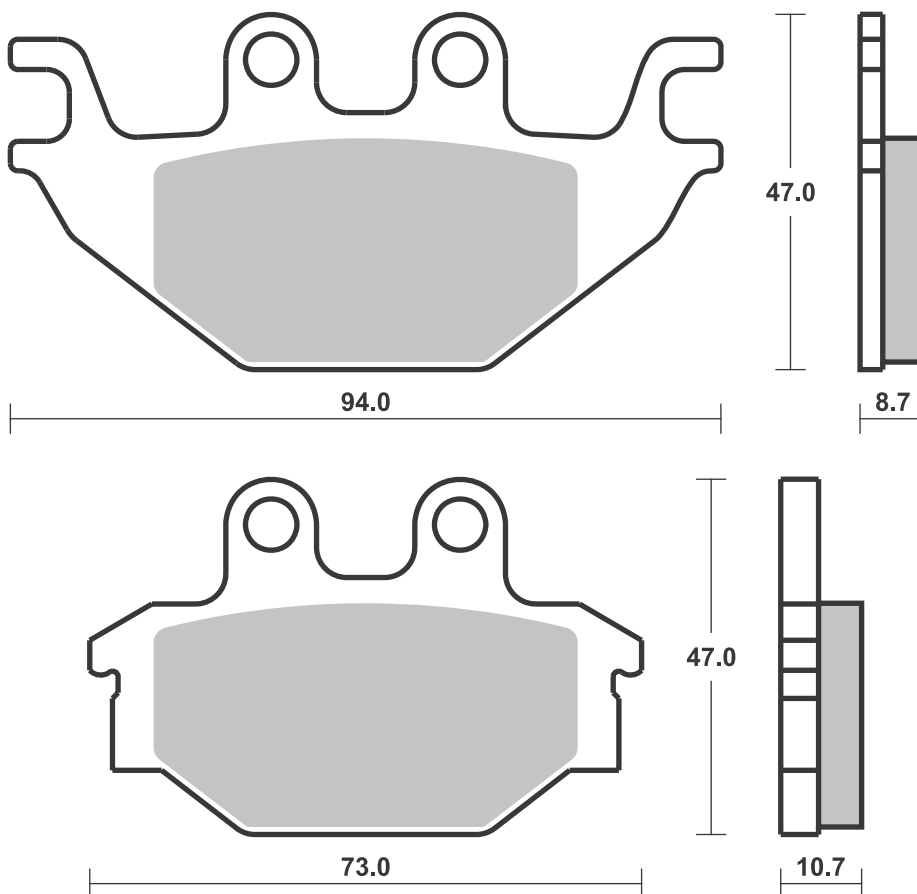



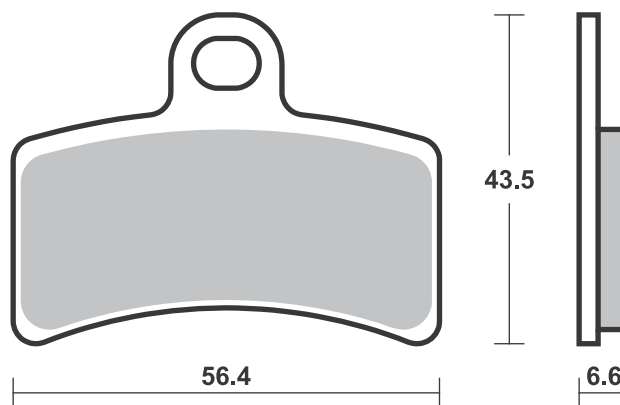
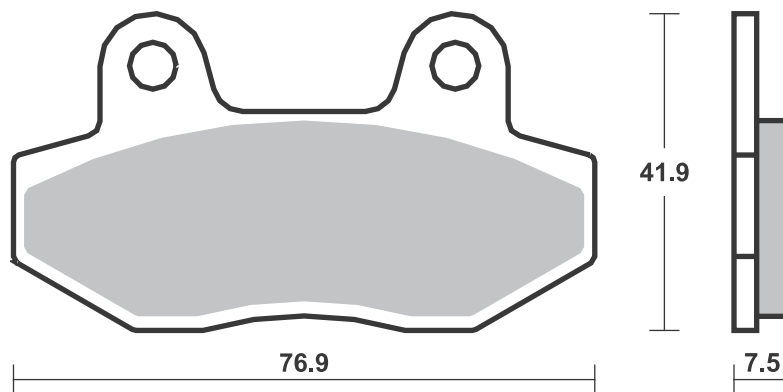
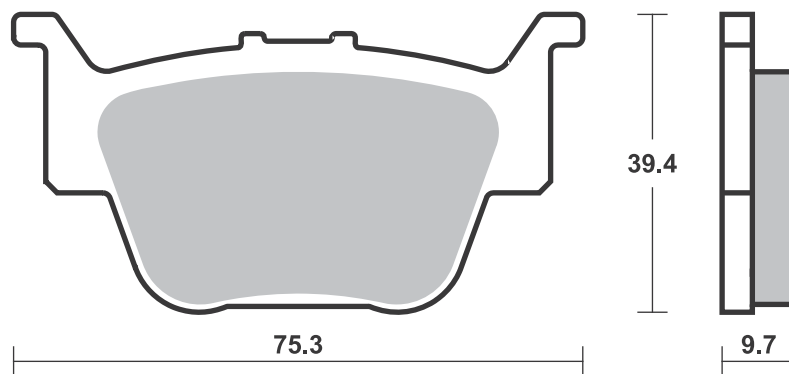



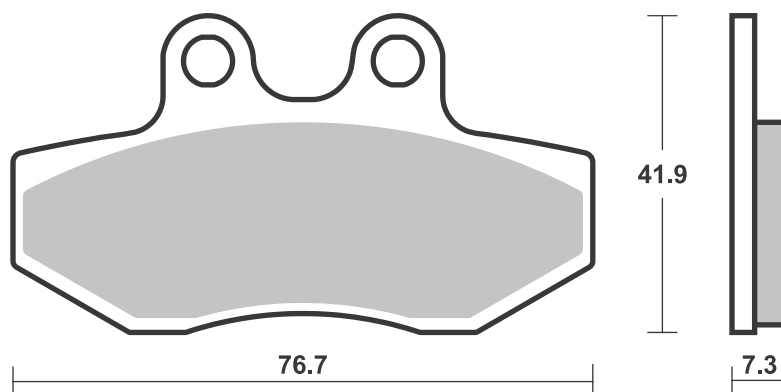
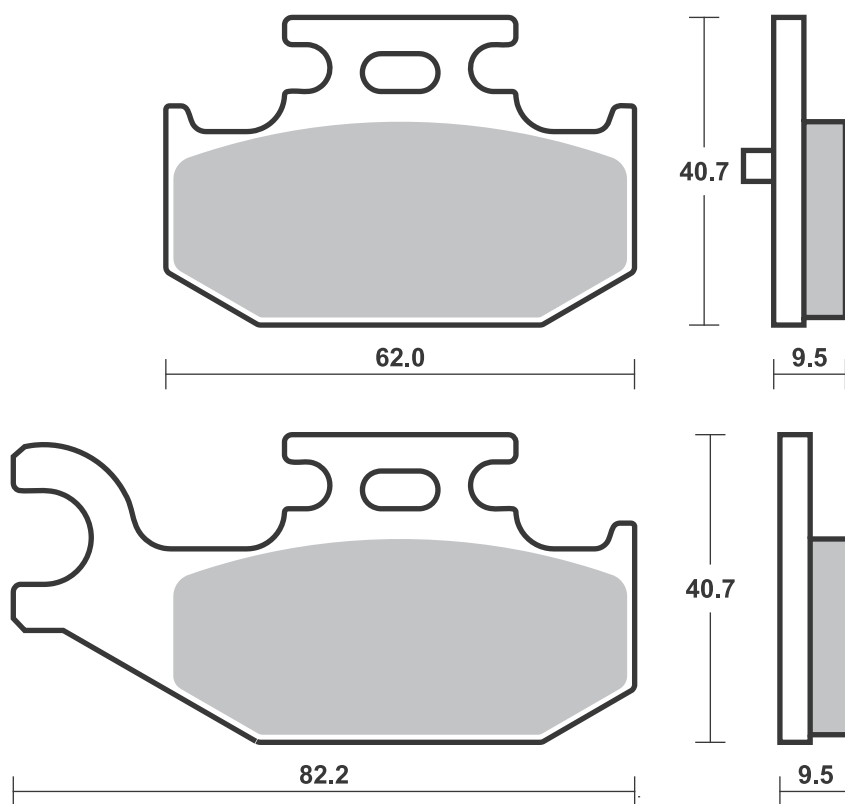



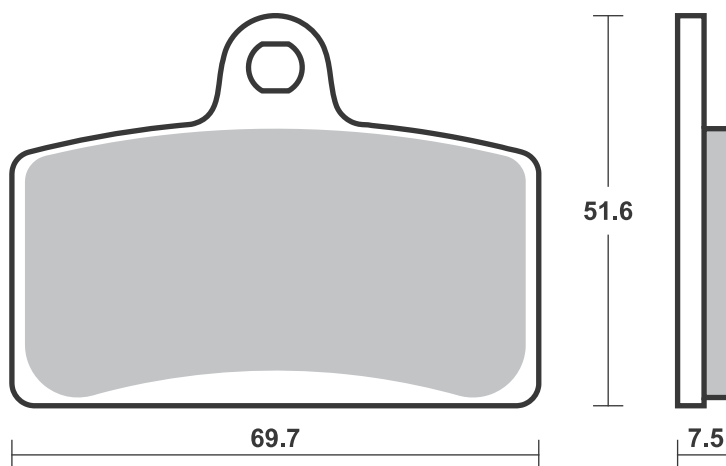
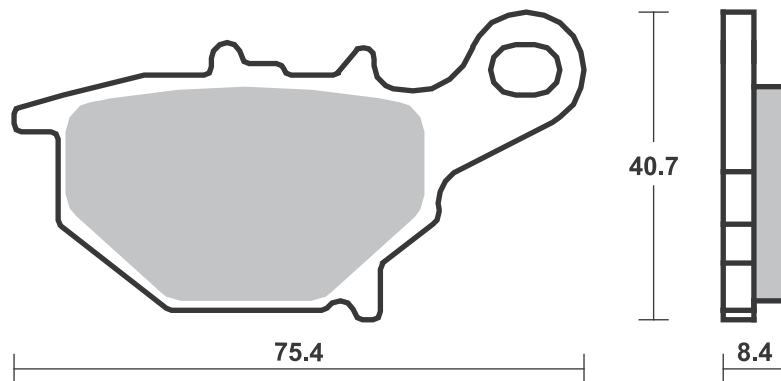
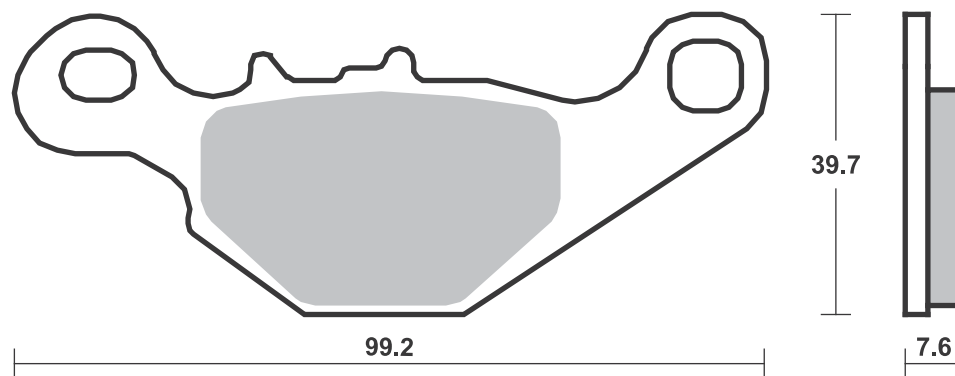





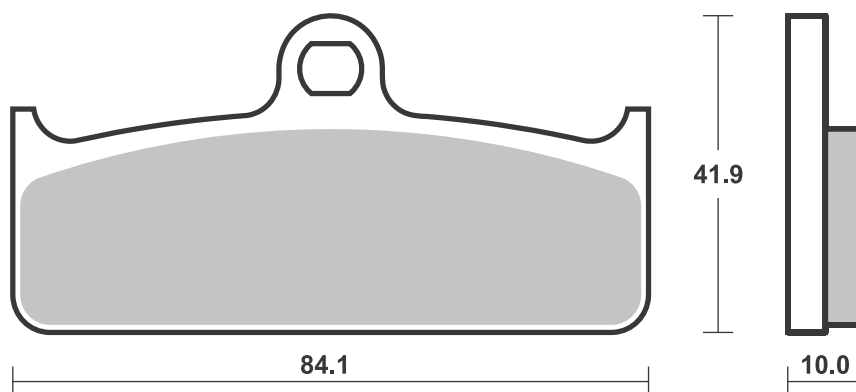
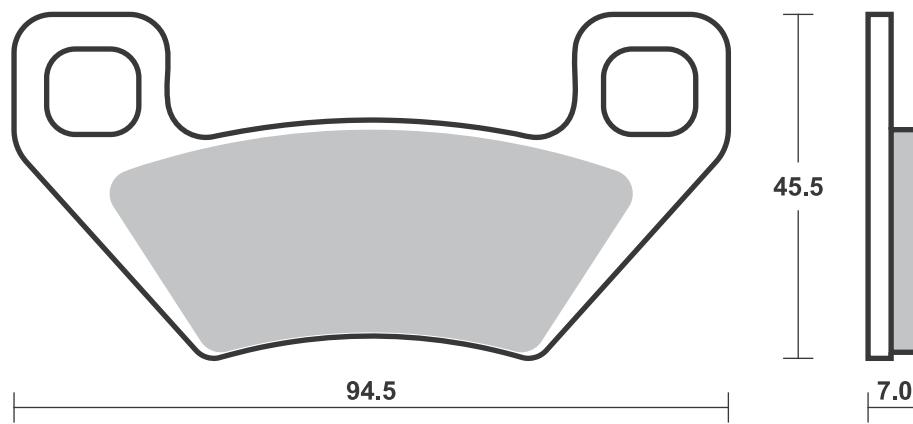



HARLEY DAVIDSON					
XL	883 R				
	Sportster	00-03	H.HS	H.LS	
XL	883 Sportster				
	Custom	00-03	H.HS	H.LS	
XLH	883 Sportster	00-03	H.HS	H.LS	
XLH	883 Sportster				
	Hugger	00-03	H.HS	H.LS	
VRSCA	1130 V-Rod	02-05	H.HS	H.LS	
VRSCB	1130 V-Rod	04	H.HS	H.LS	
XL	1200 Sportster				
	Custom	00-03	H.HS	H.LS	
XL	1200 Sportster				
	Sport	00-03	H.HS	H.LS	
XLH	1200 Sportster	00-03	H.HS	H.LS	
FLHR/I	1450 Road King	00-06	H.HS	H.LS	
FLHRCI	1450 Road King				
	Classic	00-06	H.HS	H.LS	
FLHRS/I	1450 Road King				
	Custom	04-06	H.HS	H.LS	
FLHT/I	1450 Electra				
	Glide				
	Standard	00-06	H.HS	H.LS	
FLHTC/I	1450 Electra				
	Glide				
	Classic	00-06	H.HS	H.LS	
FLHTCUI	1450 Ultra				
	Classic				
	Electra				
	Glide	00-06	H.HS	H.LS	
FLHXI	1450 Street				
	Glide	06	H.HS	H.LS	
FLSTC	1450 Softail	06-07	H.HS	H.LS	
FLSTC/I	1450 Heritage				
	Softail				
	Classic	00-04	H.HS	H.LS	
FLSTCI	1450 Softail	06	H.HS	H.LS	
FLSTF	1450 Fat Boy	06-07	H.HS	H.LS	
FLSTF/I	1450 Fat Boy	00-04	H.HS	H.LS	
FLSTFI	1450 Fat Boy	06	H.HS	H.LS	
FLSTI	1450 Heritage				
	Softail	06	H.HS		
FLSTN/I	1450 Softail				
	Deluxe	06	H.HS	H.LS	
FLSTS/I	1450 Heritage				
	Springer	00-03		H.LS	
FLSTSC/I	1450 Springer				
	Softail				
	Classic	06		H.LS	
FLTR/I	1450 Road				
	Glide				
	Classic	00-06	H.HS	H.LS	
FXD	1450 Dyna				
	Super				
	Glide	00-03	H.HS	H.LS	
FXDBI	1450 Dyna				
	Street Bob	06	H.HS	H.LS	
FXDC/I	1450 Dyna				
	Super				
	Glide				
	Custom	05-06	H.HS	H.LS	
FXDI	1450 35th				
	Anniversary				
	Super				
	Glide	06	H.HS		
FXDI	1450 Dyna				
	Super				
	Glide	04-07	H.HS	H.LS	



HARLEY DAVIDSON					
FXDL	1450 Dyna Low				
	Rider	00-03	H.HS	H.LS	
FXDLI	1450 Dyna Low				
	Rider	04-06	H.HS	H.LS	
FXDS	1450 Dyna				
	Convertible	00-02	H.HS	H.LS	
FXDWG	1450 Dyna Wide				
	Glide	00-03	H.HS	H.LS	
FXDWGI	1450 Dyna Wide				
	Glide	04-06	H.HS	H.LS	
FXDX	1450 Dyna				
	Super				
	Glide				
	Sport	00-03	H.HS	H.LS	
FXDXI	1450 Dyna				
	Super				
	Glide				
	Sport	04-06	H.HS	H.LS	
FXDXT	1450 Dyna				
	Super				
	Glide				
	T-Sport	00-03	H.HS	H.LS	
FXST/I	1450 Softail				
	Standard	00-05	H.HS	H.LS	
FXST/I	1450 Softail				
	Standard	06	H.HS		
FXSTB/I	1450 Night Train	00-05	H.HS	H.LS	
FXSTB/I	1450 Night Train	06	H.HS		
FXSTD/I	1450 Softail				
	Deuce	00-05	H.HS	H.LS	
FXSTD/I	1450 Softail				
	Deuce	06	H.HS		
FXSTS/I	1450 Softail	05		H.LS	
FXSTS/I	1450 Springer				
	Softail	00-04		H.LS	
FLHR	1584 Road King	07	H.HS	H.LS	
FLHRC	1584 Road King				
	Classic	07	H.HS	H.LS	
FLHRS	1584 Road King				
	Custom	07	H.HS	H.LS	
FLHT	1584 Electra				
	Glide				
	Standard	07	H.HS	H.LS	
FLHTC	1584 Electra				
	Glide				
	Classic	07	H.HS	H.LS	
FLHTCU	1584 Ultra				
	Classic				
	Electra				
	Glide	07-08	H.HS	H.LS	
FLHX	1584 Street				
	Glide	07	H.HS	H.LS	
FLSTC	1584 Heritage				
	Softail				
	Classic	07	H.HS		
FLSTF	1584 Fat Boy	07	H.HS		
FLSTN	1584 Softail				
	Deluxe	07	H.HS		
FXD	1584 Dyna				
	Super				
	Glide	07	H.HS	H.LS	
FXDB	1584 Dyna				
	Street Bob	07	H.HS	H.LS	
FXDC	1584 Dyna				
	Super				
	Glide				
	Custom	07	H.HS	H.LS	



HARLEY DAVIDSON					
FXDL	1584 Dyna Low				
	Rider	07	H.HS	H.LS	
FXDWG	1584 Dyna				
	Wide				
	Glide	07	H.HS	H.LS	
FXST	1584 Softail				
	Standard	07	H.HS		
FXSTB	1584 Night Train	07	H.HS		
FXSTC	1584 Softail				
	Custom	07	H.HS		
FXSTD	1584 Softail				
	Deuce	07	H.HS		

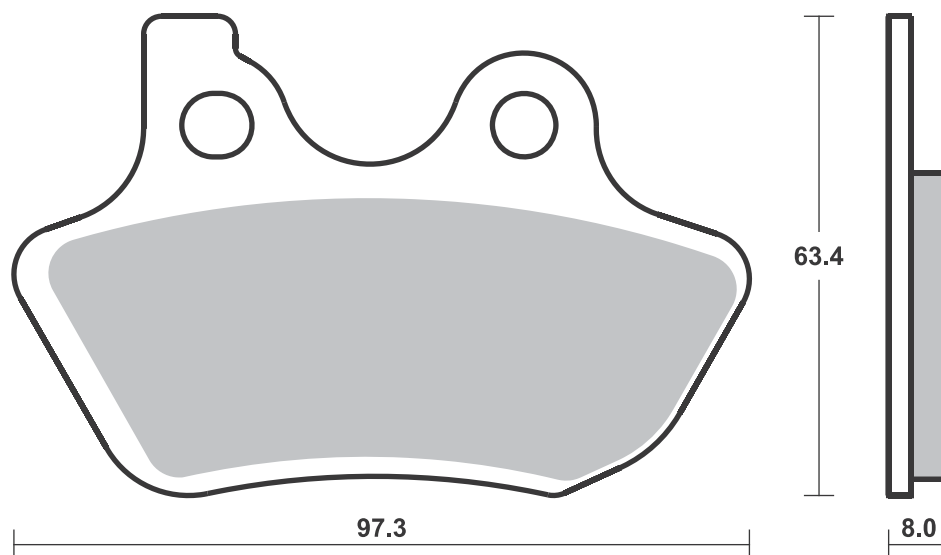
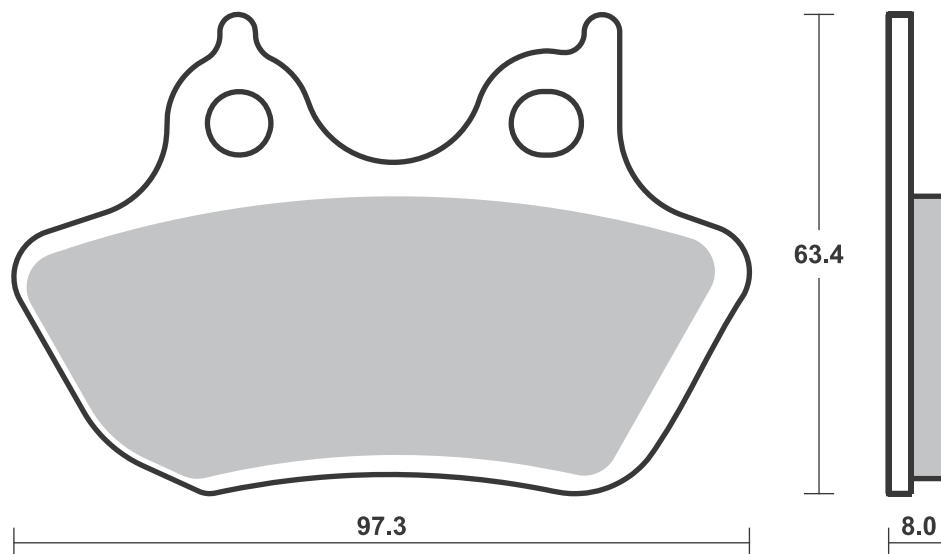

**SBS 827** Recommended compound

<b>ARCTIC CAT</b>			
250 2x4 (Man.			
Hand Brake)	99-04	<b>ATS</b>	
250 4x4 (Man.			
Hand Brake)	00-04	<b>ATS</b>	
300 2x4 (Man.			
Hand Brake)	98-04	<b>ATS</b>	
300 4x4 (Man.			
Hand Brake)	98-05	<b>ATS</b>	
375 2x4/4x4			
(Man.			
Hand Brake)	02	<b>ATS</b>	
400 2x4 (Man.			
Hand Brake)	98-02	<b>ATS</b>	
400 2x4/4x4 (FIS)			
Aut.(Man.			
Hand Brake)	03-04	<b>ATS</b>	
400 2x4/4x4 (FIS)			
(Man.			
Hand Brake)	02-04	<b>ATS</b>	
400 4x4 (Man.			
Hand Brake)	98-04	<b>ATS</b>	
400 TBX 4x4			
(Man.			
Hand Brake)	04	<b>ATS</b>	
454 Bear Cat			
2x4/4x4			
(Man.			
Hand Brake)	98	<b>ATS</b>	



<b>ARCTIC CAT</b>			
500 2x4 (FIS)			
(Man.			
Hand Brake)	02	<b>ATS</b>	
500 2x4 (Man.			
Hand Brake)	02	<b>ATS</b>	
500 4x4 (FIS) Aut.			
(Man.			
Hand Brake)	02-03	<b>ATS</b>	
500 4x4 (FIS)			
(Man.			
Hand Brake)	02-03	<b>ATS</b>	
500 4x4 (Man.			
Hand Brake)	98-02	<b>ATS</b>	
500 TBX 4x4			
(Man.			
Hand Brake)	03-04	<b>ATS</b>	
500 TBX 4x4			
Aut.(Man.			
Hand Brake)	02	<b>ATS</b>	
500 TRV 4x4			
(Man.			
Hand Brake)	03-04	<b>ATS</b>	

**SBS 828** Recommended compound

<b>HONDA</b>			
CBR 250 R ABS			
(Nissin cal)	11-13	<b>HS</b>	
CB 600 Hornet ABS	07-12	<b>HS</b>	
CBR 600 F ABS	11-13	<b>HS</b>	
DN-01 680	08-11	<b>HS</b>	
NC 700 D Integra	12-13	<b>HS</b>	
NC 700 SA ABS	12-13	<b>HS</b>	
NC 700 SD ABS	12-13	<b>HS</b>	
NC 700 XA ABS	12-13	<b>HS</b>	
NC 700 XD ABS	12-13	<b>HS</b>	
NT 700 Deauville			
ABS	06-12	<b>HS</b>	
NT 700 V Varadero,			
ABS	10-13	<b>HS</b>	
VT 750 C2S ABS	13-14	<b>HS</b>	
VT 750 CS ABS	13-14	<b>HS</b>	
VFR 800 Crossrunner	11-13	<b>HS</b>	
VFR 800 Interceptor	06-18	<b>HS</b>	
VFR 800 Interceptor			
ABS	06-18	<b>HS</b>	
CB 1000 R ABS	08-16	<b>HS</b>	
CB 1100	13	<b>HS</b>	
VFR 1200 XC			
Crosstourer	12-18	<b>SP</b>	
VFR 1200 XDC			
Crosstourer			
w/DCT	12-18	<b>SP</b>	
CB 1300 S	11-15	<b>HS</b>	
CTX 1300	14-18	<b>HS</b>	
ST 1300 , ABS	08-13	<b>HS</b>	



<b>HONDA</b>			
VT 1300 CXA A Fury			
ABS	10-18	<b>HS</b>	
<b>SUZUKI</b>			
C109R 1800	08-12	<b>HS</b>	

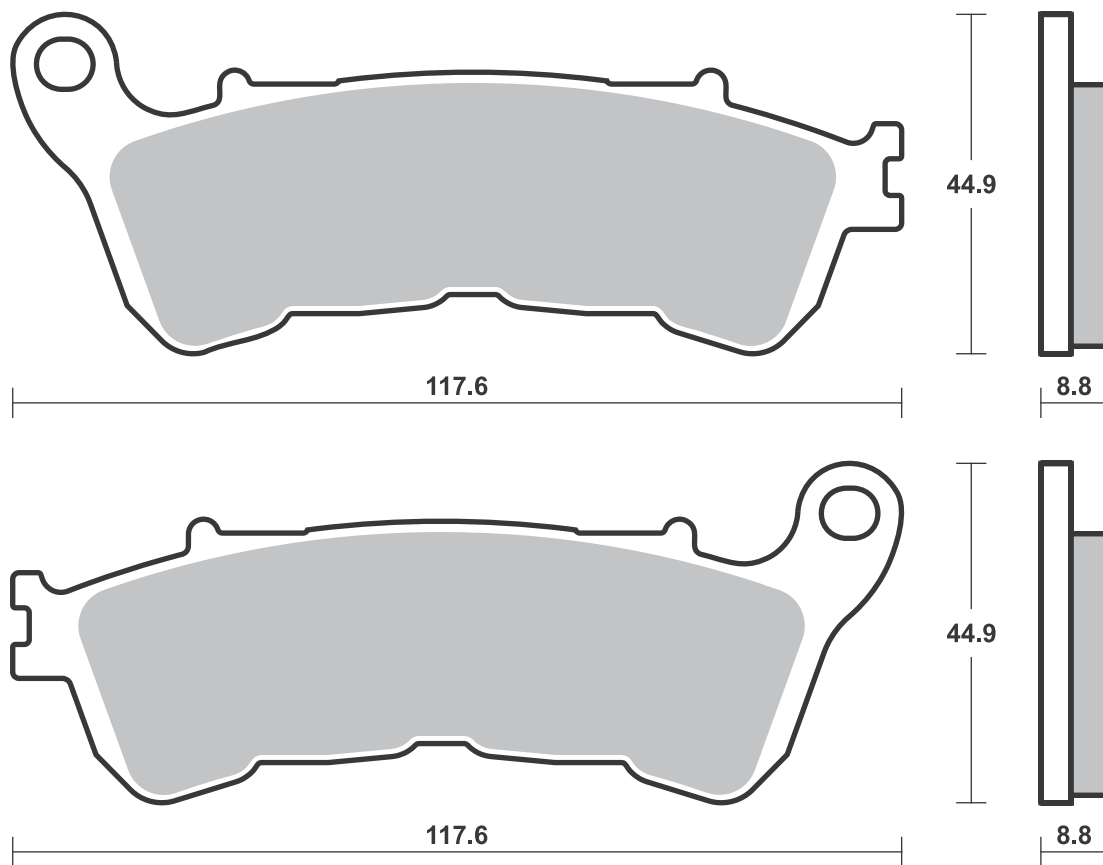
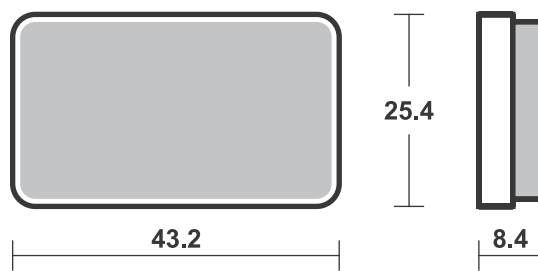



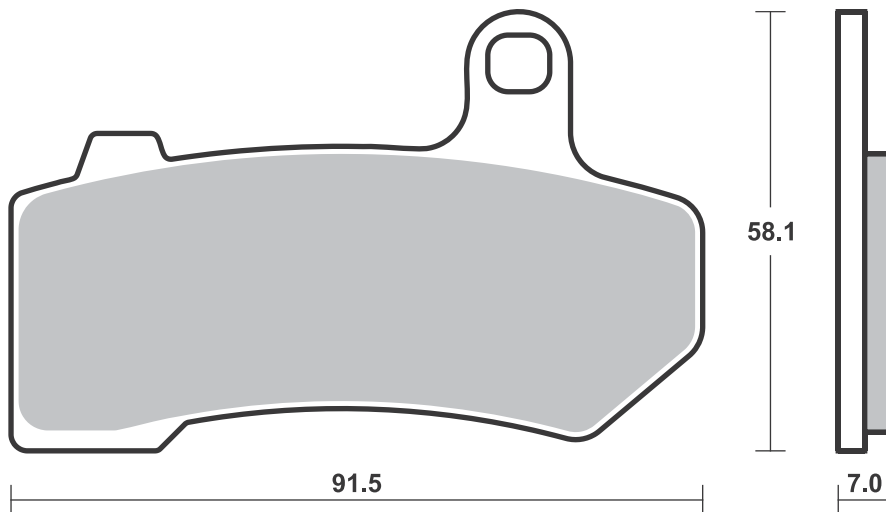
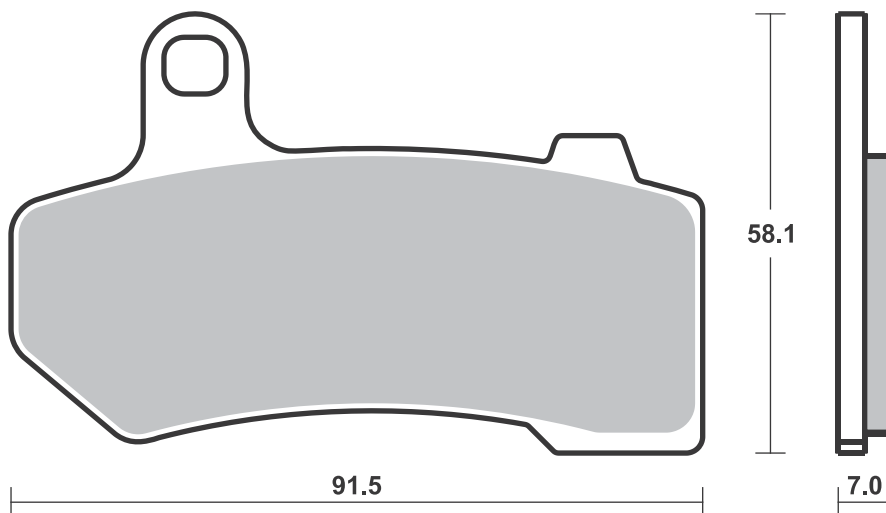
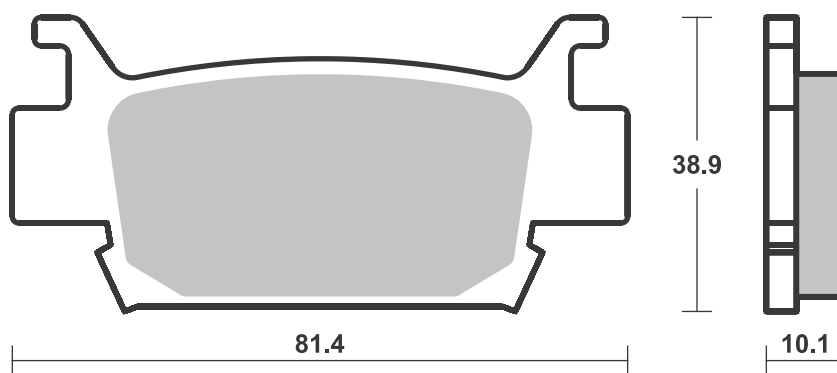





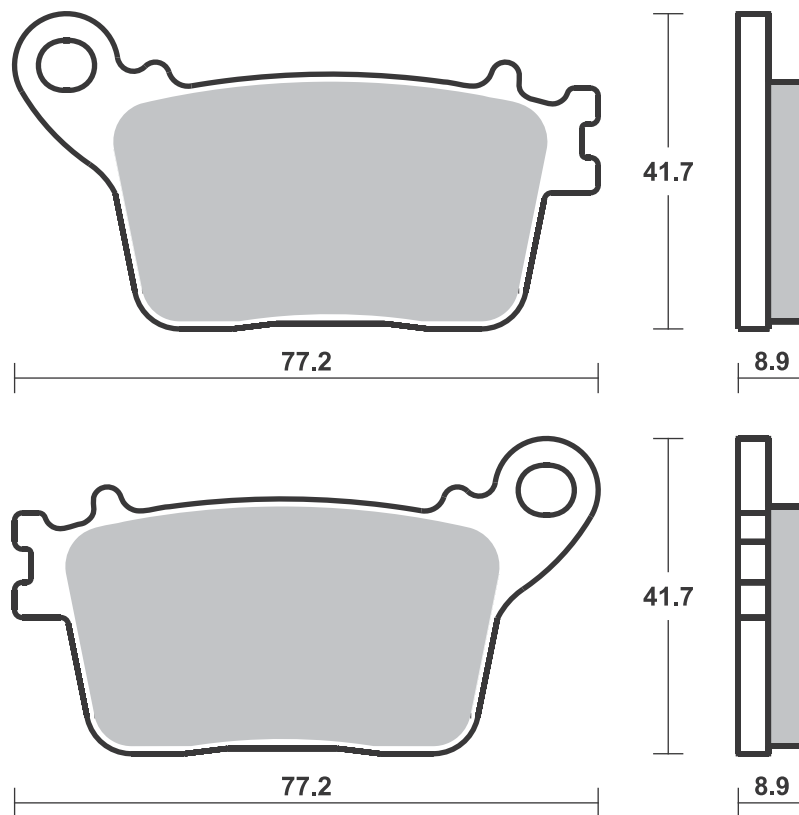
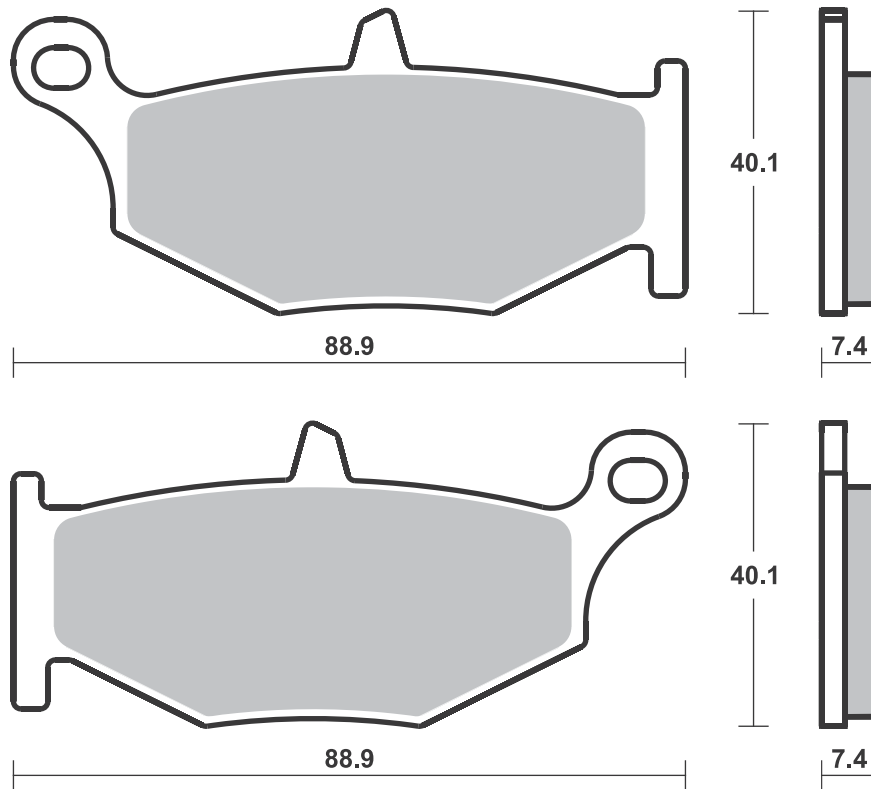



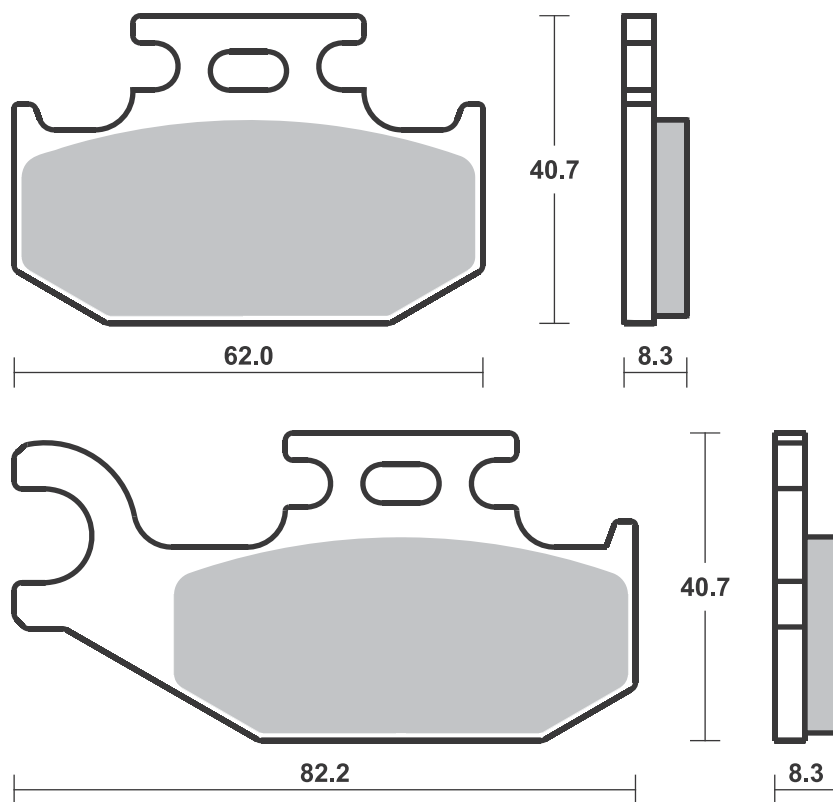
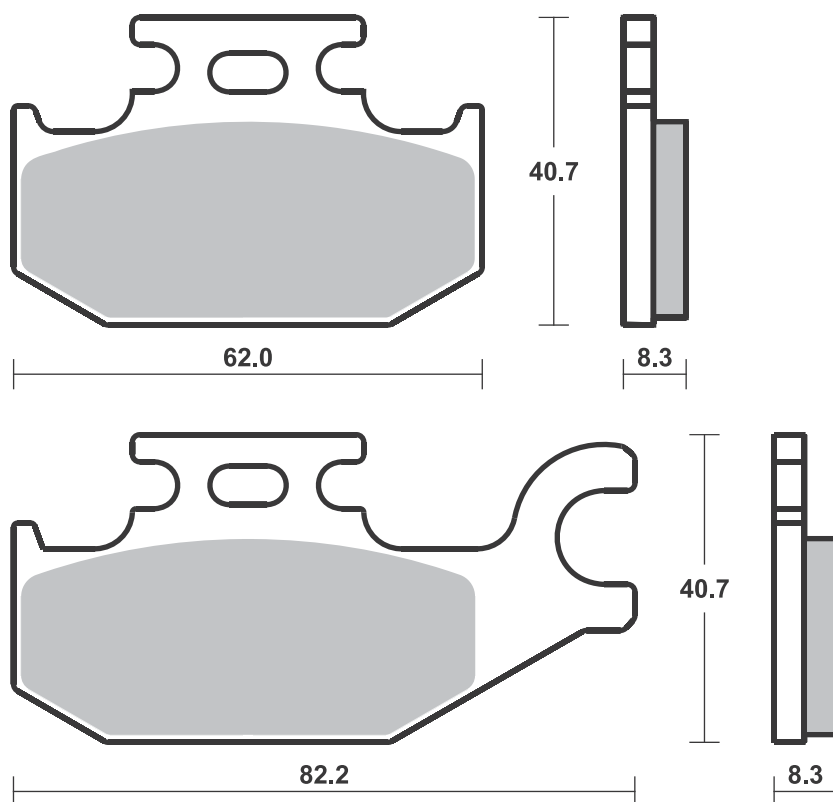

**SBS 838** Recommended compound



<b>KAWASAKI</b>			
ZX-6R	600 Ninja	07-12	<b>HS</b>
Z	750 R	11-12	<b>HS</b>
Z	1000	07-09	<b>HS</b>
ZG	1400 Concours	07-10	<b>HS</b>
ZX-14R	1400 Ninja	06-15	<b>HS</b>
ZX-14R	1400 Ninja ABS	07-15	<b>HS</b>
<b>SUZUKI</b>			
	1300 B-King	07	<b>HS</b>

**SBS 839** Recommended compound



<b>YAMAHA</b>			
YZF	1000 R1(4-pad)	07-14	<b>SP</b>
YZF	1000 R1(4-pad)		
	ABS	12-14	<b>SP</b>
VMX	1700 V-Max	09-18	<b>HS</b>

**SBS 840** Recommended compound



<b>YAMAHA</b>			
YZ	125	08-18	<b>RSI</b>
WR	250 F Efi	18-	<b>SI</b>
WR	250 F Enduro		
	GP	18-	<b>SI</b>
YZ	250	08-18	<b>RSI</b>
YZ	250 F	07-13	<b>RSI</b>
YZ	250 F Efi	14-18	<b>RSI</b>
YZ	250 FX Efi	15	<b>SI</b>
YZ	250 X	16-17	<b>SI</b>
WR	450 F Efi	16-18	<b>SI</b>
WR	450 F Enduro		
	GP	18-	<b>SI</b>
YZ	450 F	08-09	<b>RSI</b>
YZ	450 F Efi	10-17	<b>RSI</b>
YZ	450 F Efi	18-	<b>RSI</b>
YZ	450 FX Efi	16	<b>SI</b>

Brake Pad 1:1 Drawings, Compounds, Fitments

Drawings 1:1

Available compounds **HS • DC • RS • DS • SP**

**SBS 838**

1 set = 4 pcs.

HS / SP - Th. 7.8  
RS / DC / DS - Th. 9.0

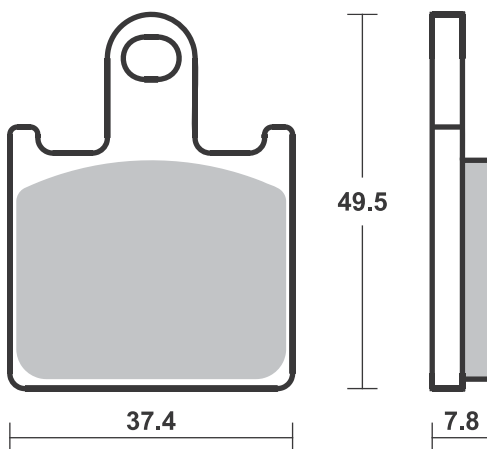

Available compounds **HS • DC • RS • DS • SP**

**SBS 839**

1 set = 2 pcs. small / large

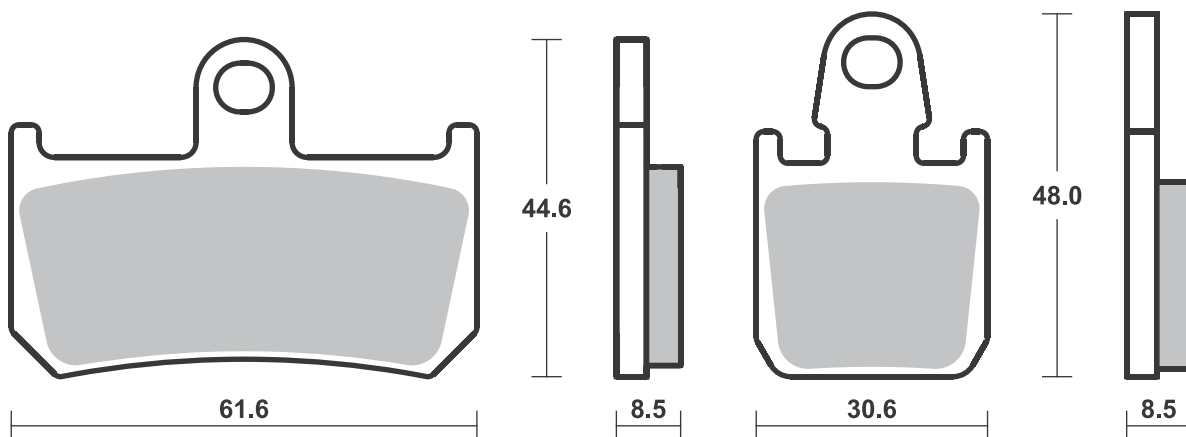

Available compounds **SI • RSI • CS**

**SBS 840**

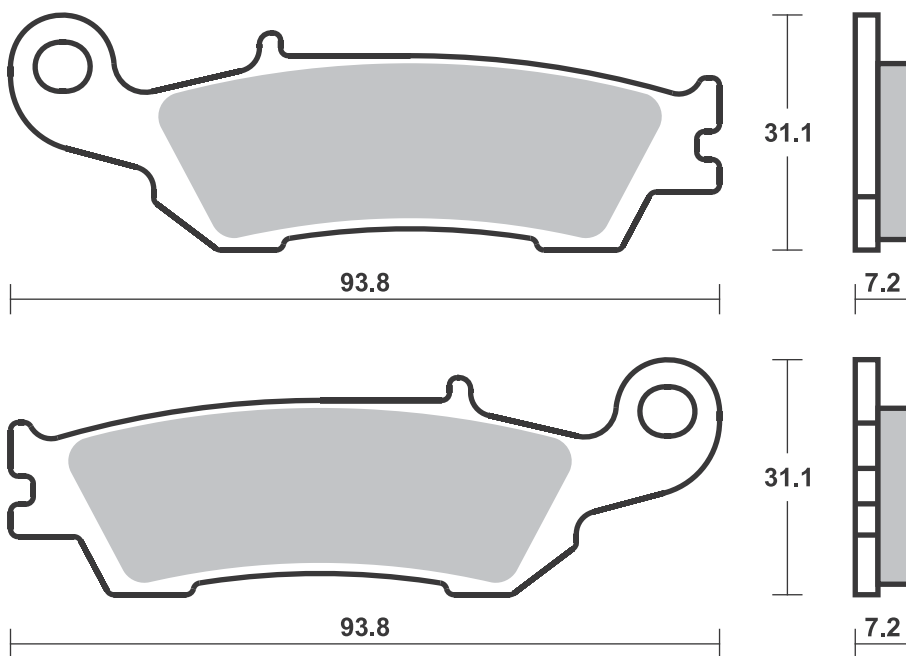



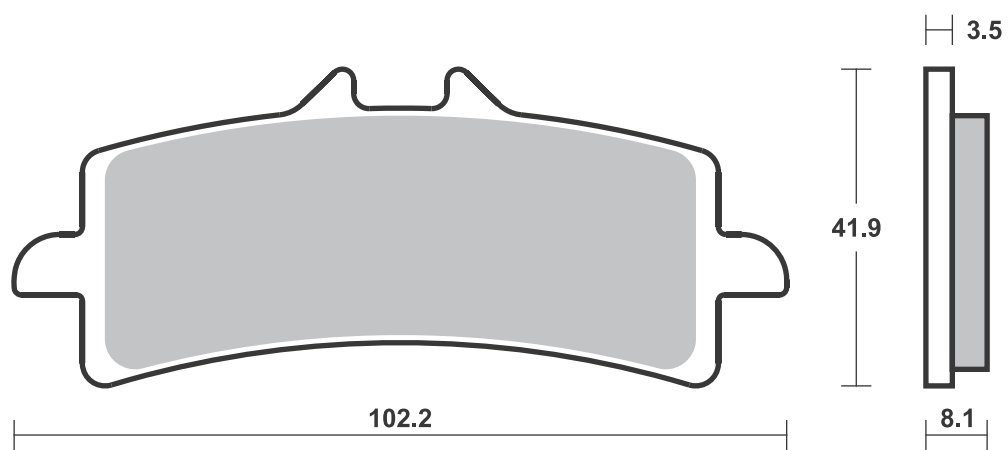





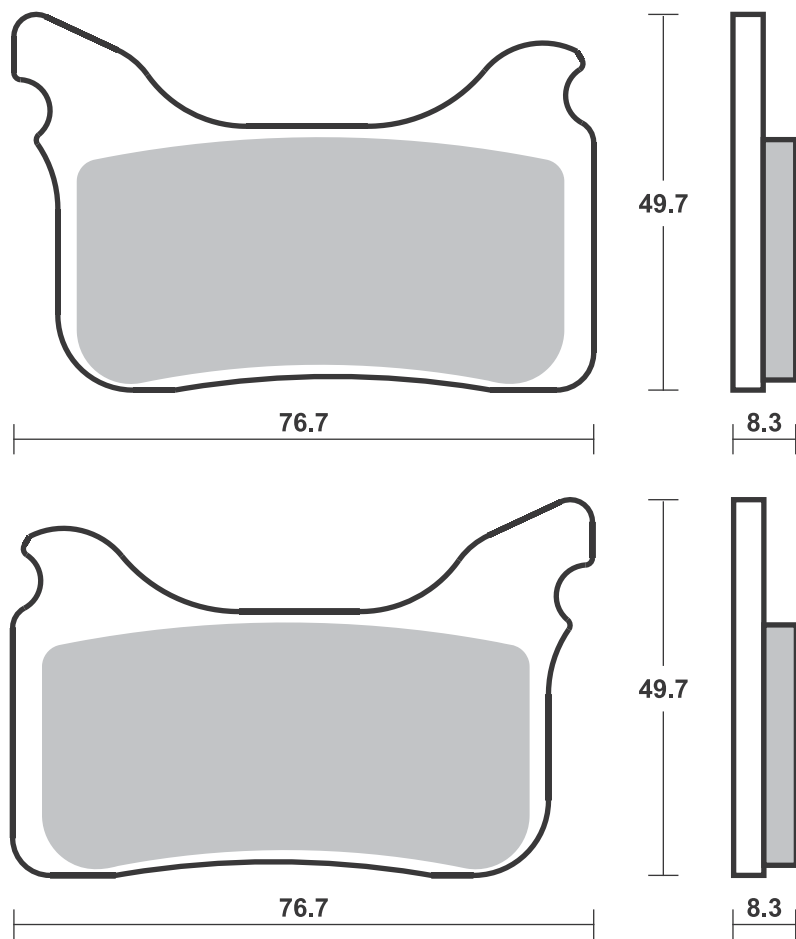

1 set = 4 pcs.

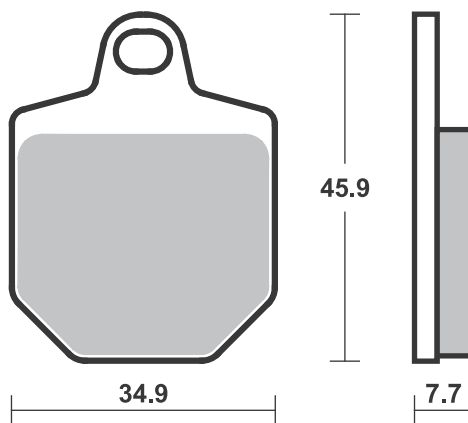



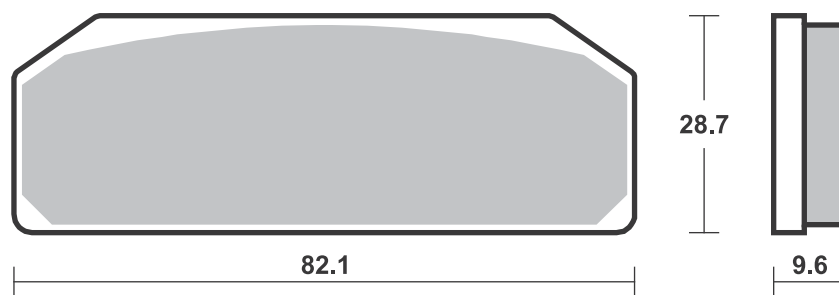
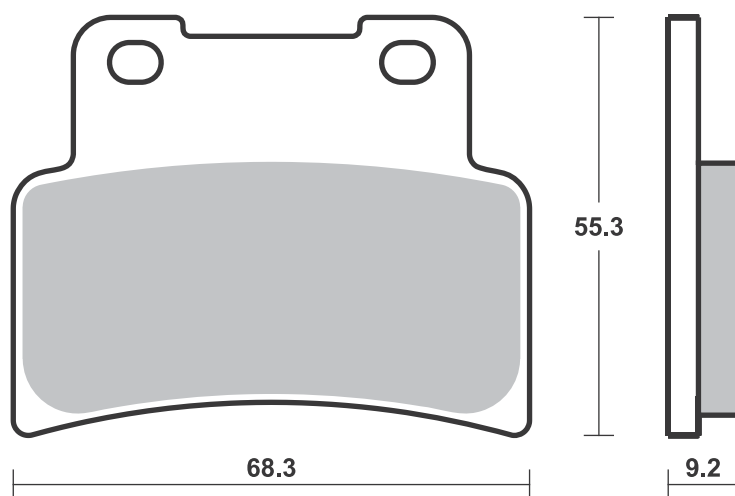



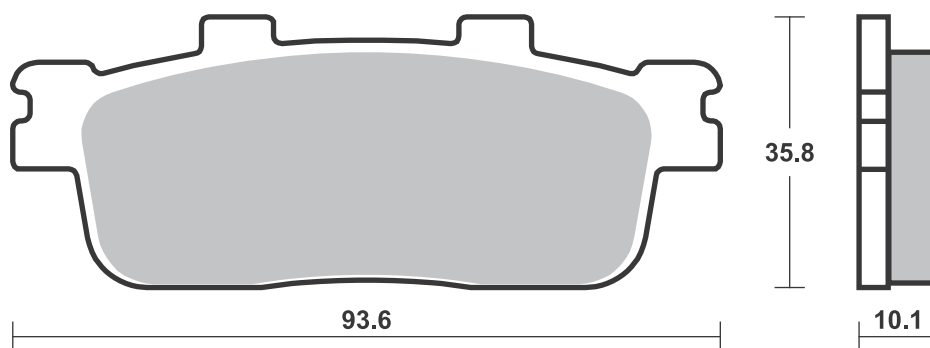
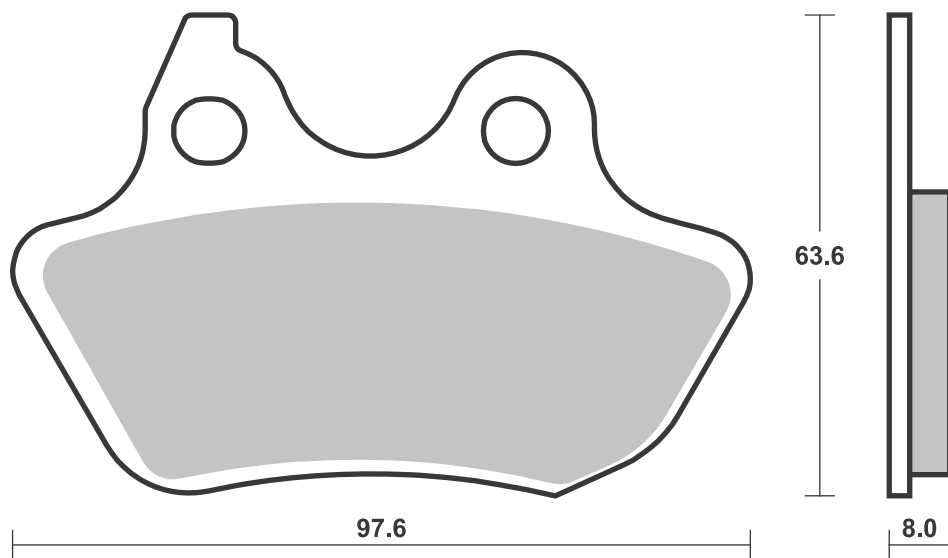
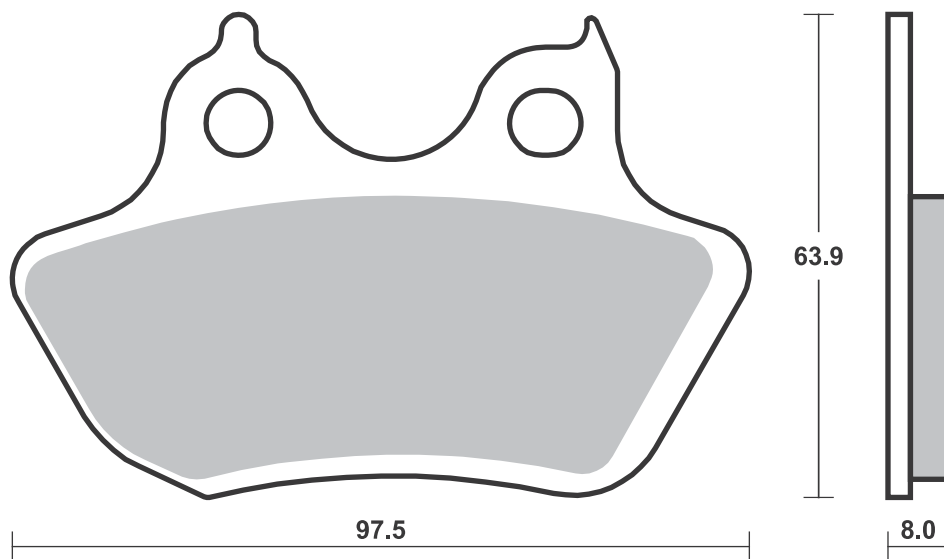



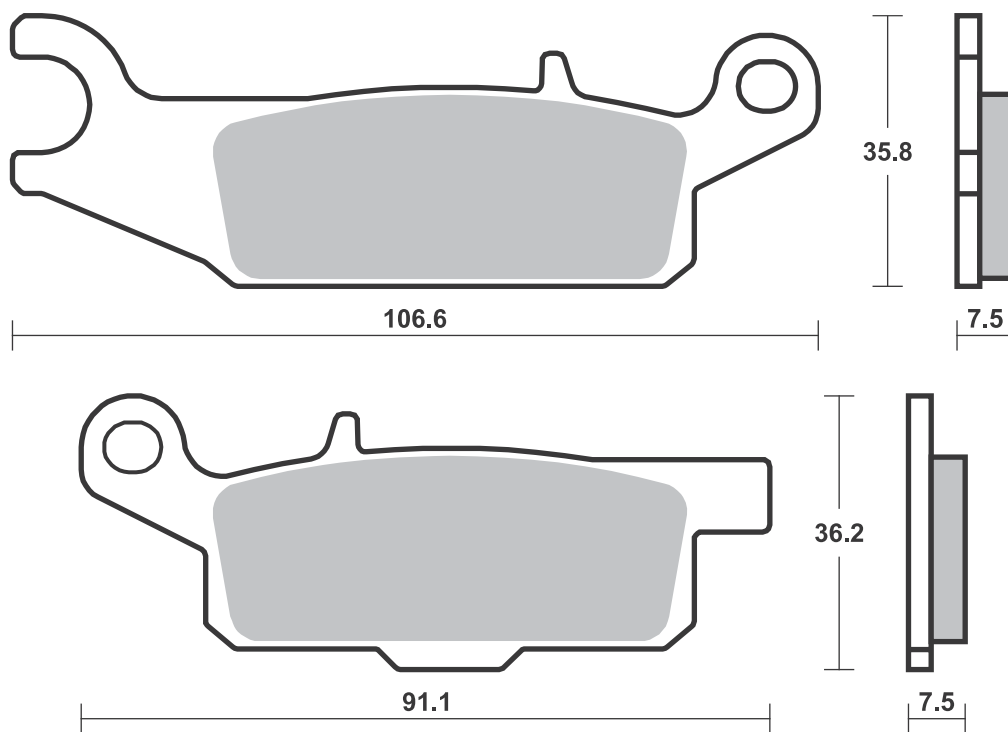
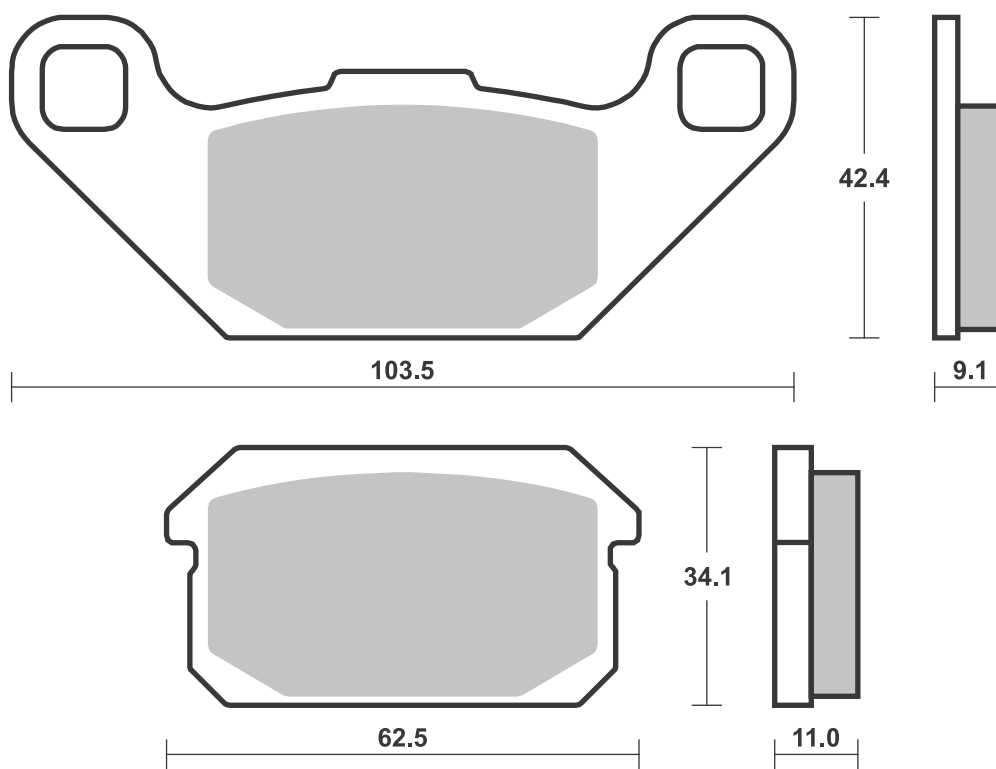





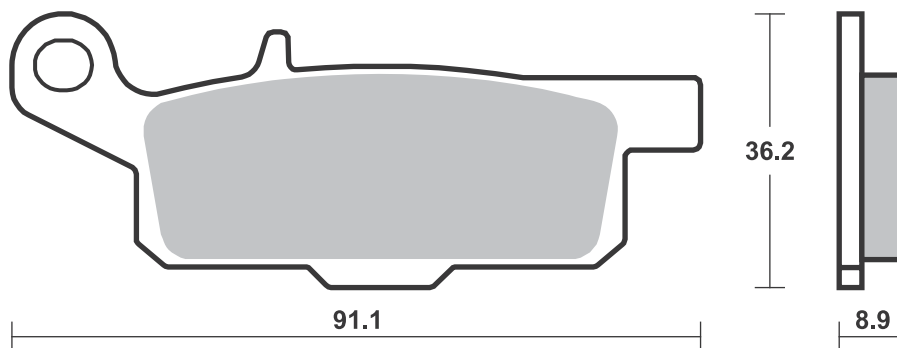
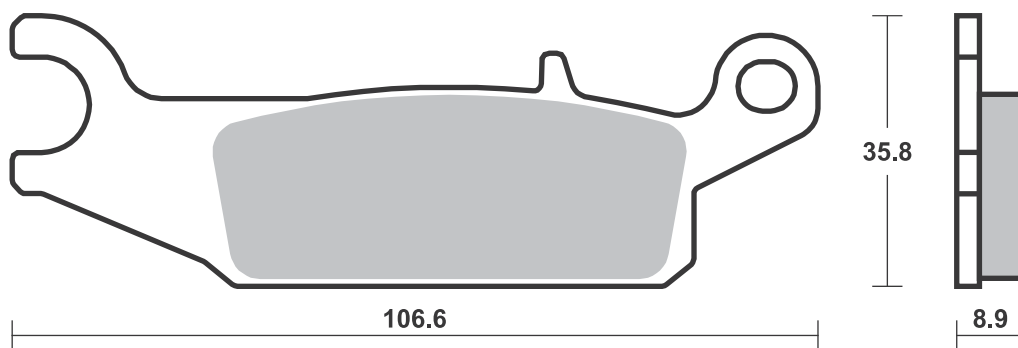
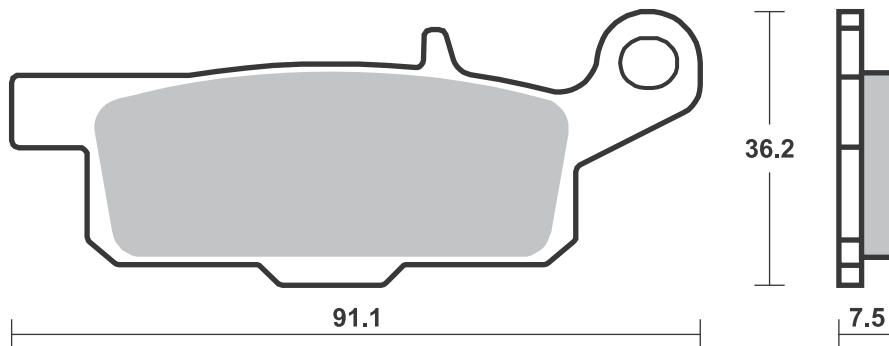
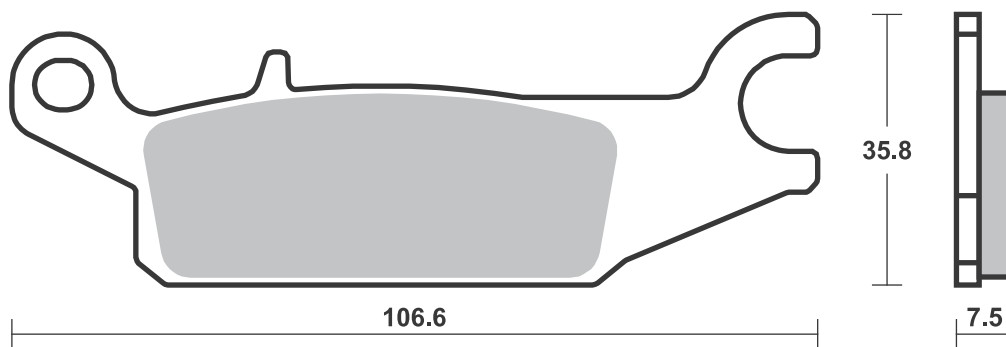



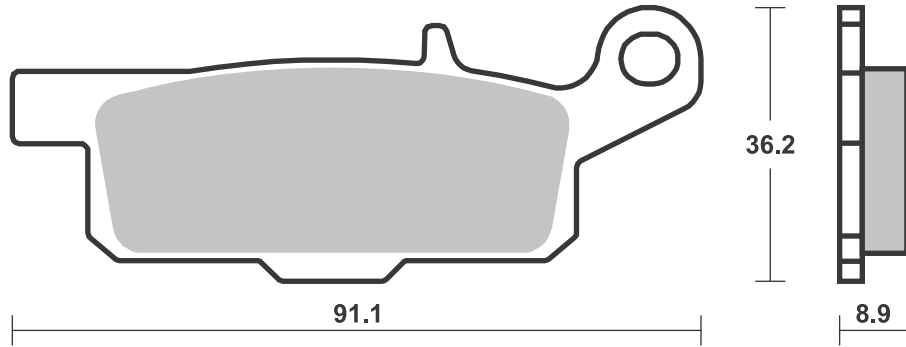
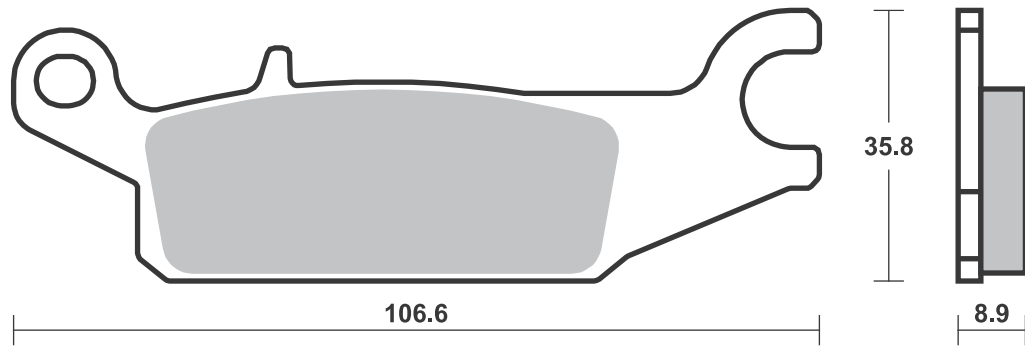



HARLEY DAVIDSON			
FLSTC	1584	Heritage	
		Softail	
		Classic	08-11 <b>H.HS</b>
FLSTF	1584	Fat Boy	08-11 <b>H.HS</b>
FLSTFB	1584	Fat Boy	
		Special	10-11 <b>H.HS</b>
FLSTN	1584	Softail	
		Deluxe	08-11 <b>H.HS</b>
FXCW	1584	Rocker	08-09 <b>H.HS</b>
FXCWC	1584	Rocker C	08-13 <b>H.HS</b>
FXD	1584	Dyna	
		Super	
		Glide	08-10 <b>H.HS</b>
FXDB	1584	Dyna	
		Street Bob	08-13 <b>H.HS</b>
FXDC	1584	Dyna	
		Super	
		Glide	
		Custom	08-13 <b>H.HS</b>
FXDF	1584	Fat Bob	08-11 <b>H.HS</b>
FXDL	1584	Dyna	
		Low Rider	08-13 <b>H.HS</b>
FXDWG	1584	Dyna	
		Wide	
		Glide	08-10 <b>H.HS</b>
FXST	1584	Softail	
		Standard	08-14 <b>H.HS</b>
FXSTB	1584	Night Train	08-09 <b>H.HS</b>
FXSTC	1584	Softail	
		Custom	08-10 <b>H.HS</b>
FLD	1690	Switchback	
			12-16 <b>H.HS</b>
FLHRC	1690	Road	
		King	
		Classic	11-16 <b>H.HS</b>
FLHTC	1690	Electra	
		Glide	
		Classic	11-16 <b>H.HS</b>
FLHTK	1690	Ultra	
		Electra	
		Glide	11-16 <b>H.HS</b>
FLS	1690	Softail Slim	12-14 <b>H.HS</b>
FLSTC	1690	Heritage	
		Softail	
		Classic	12-14 <b>H.HS</b>
FLSTF	1690	Fat Boy	12-14 <b>H.HS</b>
FLSTF	1690	Fat Boy	
		Special	12-14 <b>H.HS</b>
FLSTFB	1690	Fat Boy	12-14 <b>H.HS</b>
FLSTN	1690	Softail	
		Deluxe	12-14 <b>H.HS</b>
FXDB	1690	Dyna	
		Street Bob	14-17 <b>H.HS</b>
FXDBA	1690	Dyna	
		Street Bob	13-17 <b>H.HS</b>
FXDBB	1690	Dyna	
		Street Bob	14-17 <b>H.HS</b>
FXDBP	1690	Dyna	
		Street Bob	13-17 <b>H.HS</b>
FXDC	1690	Dyna	
		Super	
		Glide	
		Custom	14 <b>H.HS</b>
FXDF	1690	Dyna	
		Wide	
		Glide	12-17 <b>H.HS</b>
FXDF	1690	Fat Bob	12-17 <b>H.HS</b>



HARLEY DAVIDSON			
FXDL	1690	Dyna Low	
		Rider	14-17 <b>H.HS</b>
FXDLS	1690	Dyna Low	
		Rider S	17 <b>H.HS</b>
FXS	1690	Blackline	13-17 <b>H.HS</b>
FXSB	1690	Breakout	14 <b>H.HS</b>
FLSTNSE	1802	CVO	
		Softail	
		Deluxe	14 <b>H.HS</b>
FXSBSE	1802	CVO	
		Breakout	13-14 <b>H.HS</b>

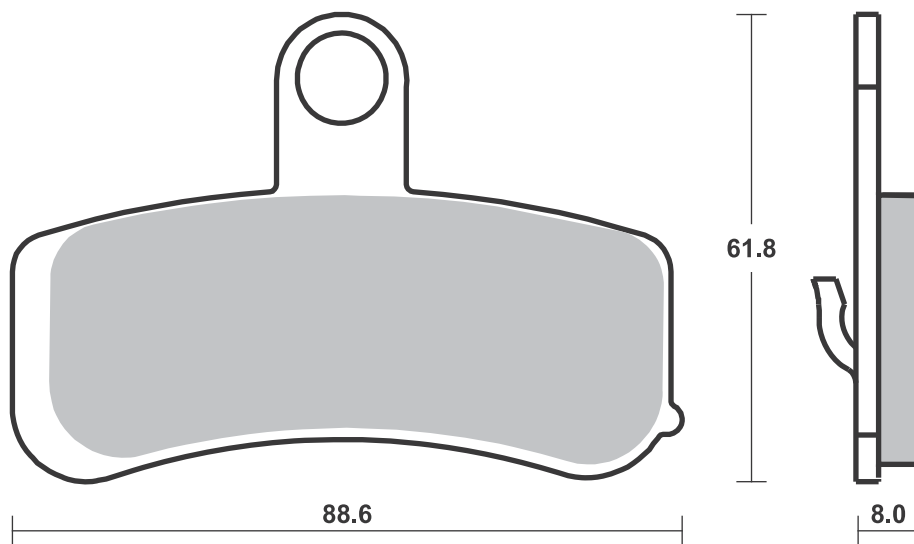
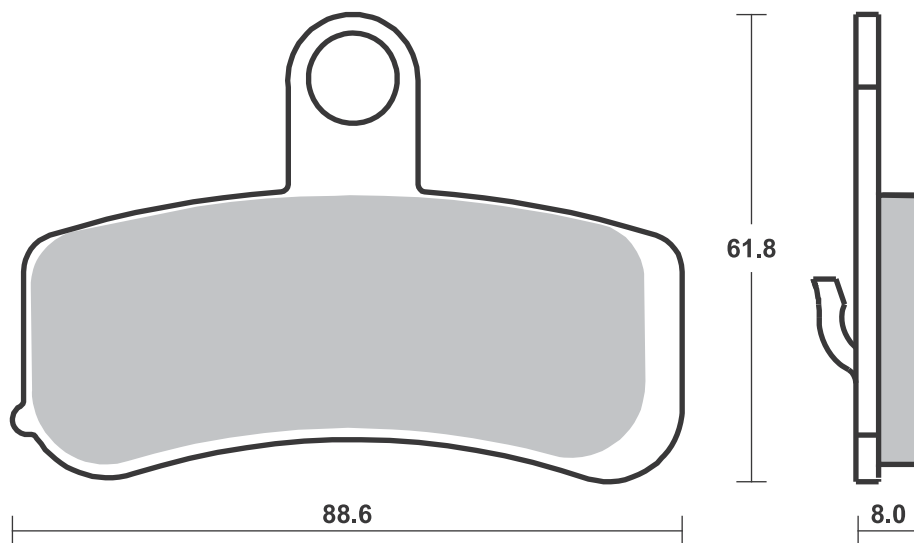

**SBS 854** Recommended compound



HARLEY DAVIDSON			
FLSTC	1584 Heritage		
	Softail		
	Classic	08-11	<b>H.L.S</b>
FLSTF	1584 Fat Boy	08-11	<b>H.L.S</b>
FLSTFB	1584 Fat Boy		
	Special	10-11	<b>H.L.S</b>
FLSTN	1584 Softail		
	Deluxe	08-11	<b>H.L.S</b>
FXCW	1584 Rocker	08-09	<b>H.L.S</b>
FXCWC	1584 Rocker C	08-13	<b>H.L.S</b>
FXD	1584 Dyna		
	Super		
	Glide	08-10	<b>H.L.S</b>
FXDB	1584 Dyna		
	Street		
	Bob	08-13	<b>H.L.S</b>
FXDC	1584 Dyna		
	Super		
	Glide		
	Custom	08-13	<b>H.L.S</b>
FXDF	1584 Fat Bob	08-11	<b>H.L.S</b>
FXDL	1584 Dyna Low		
	Rider	08-13	<b>H.L.S</b>
FXDWG	1584 Dyna		
	Wide Glide	08-10	<b>H.L.S</b>
FXST	1584 Softail		
	Standard	08-17	<b>H.L.S</b>
FXSTB	1584 Night Train	08-09	<b>H.L.S</b>
FXSTC	1584 Softail		
	Custom	08-10	<b>H.L.S</b>
FLD	1690 Switchback		
		12-16	<b>H.L.S</b>
FLHRC	1690 Road King		
	Classic	11-16	<b>H.L.S</b>



HARLEY DAVIDSON			
FLHTC	1690 Electra		
	Glide		
	Classic	11-16	<b>H.L.S</b>
FLHTK	1690 Ultra		
	Electra		
	Glide	11-16	<b>H.L.S</b>
FLS	1690 Softail		
	Slim	12-17	<b>H.L.S</b>
FLSTC	1690 Heritage		
	Softail		
	Classic	12-17	<b>H.L.S</b>
FLSTF	1690 Fat Boy	12-17	<b>H.L.S</b>
FLSTF	1690 Fat Boy		
	Special	12-14	<b>H.L.S</b>
FLSTFB	1690 Fat Boy	12-17	<b>H.L.S</b>
FLSTN	1690 Softail		
	Deluxe	12-17	<b>H.L.S</b>
FXDB	1690 Dyna		
	Street Bob	14-17	<b>H.L.S</b>
FXDBA	1690 Dyna		
	Street Bob	13-17	<b>H.L.S</b>
FXDBB	1690 Dyna		
	Street Bob	14-17	<b>H.L.S</b>
FXDBP	1690 Dyna		
	Street Bob	13-17	<b>H.L.S</b>
FXDC	1690 Dyna		
	Super		
	Glide		
	Custom	14	<b>H.L.S</b>
FXDF	1690 Dyna		
	Wide Glide	12-17	<b>H.L.S</b>
FXDF	1690 Fat Bob	12-17	<b>H.L.S</b>
FXDL	1690 Dyna Low		
	Rider	14-17	<b>H.L.S</b>



HARLEY DAVIDSON			
FXDLS	1690 Dyna Low		
	Rider S	17	<b>H.L.S</b>
FXS	1690 Blackline	13-17	<b>H.L.S</b>
FXSB	1690 Breakout	14-17	<b>H.L.S</b>
FLSS	1802 Softail		
	Slim S	16-17	<b>H.L.S</b>
FLSTFBS	1802 Fat Boy S	16-17	<b>H.L.S</b>
FLSTNSE	1802 CVO		
	Softail		
	Deluxe	14-17	<b>H.L.S</b>
FXSBSE	1802 CVO		
	Breakout	13-14	<b>H.L.S</b>

**SBS 856** Recommended compound



BUELL			
	1125 CR	09-10	<b>HS</b>
	1125 R	08-10	<b>HS</b>
XB12R	1200 Firebolt	09-10	<b>HS</b>
XB12Scg	1200 Lightning	09-10	<b>HS</b>
XB12Ss	1200 Lightning		
	Long	09-10	<b>HS</b>
EBR			
	1190 RS	12-15	<b>HS</b>
	1190 RX	14-15	<b>HS</b>
	1190 SX	14-15	<b>HS</b>

Brake Pad 1:1 Drawings, Compounds, Fitments

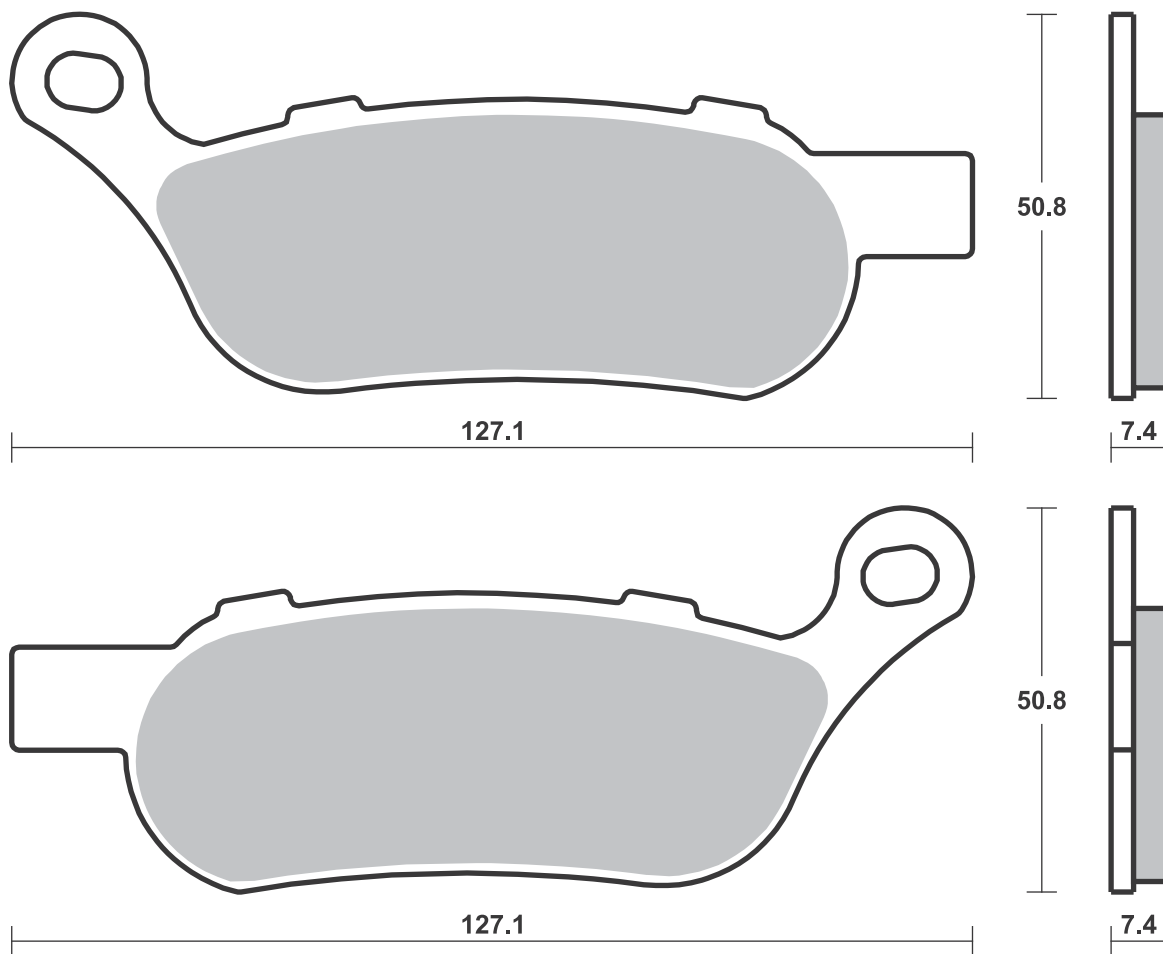

1 set = 4 pcs.

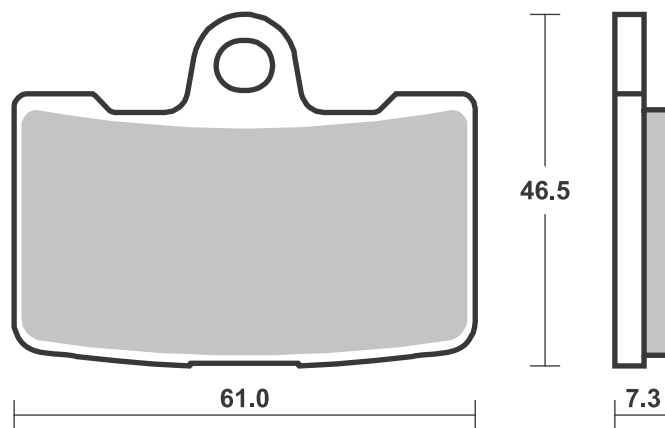





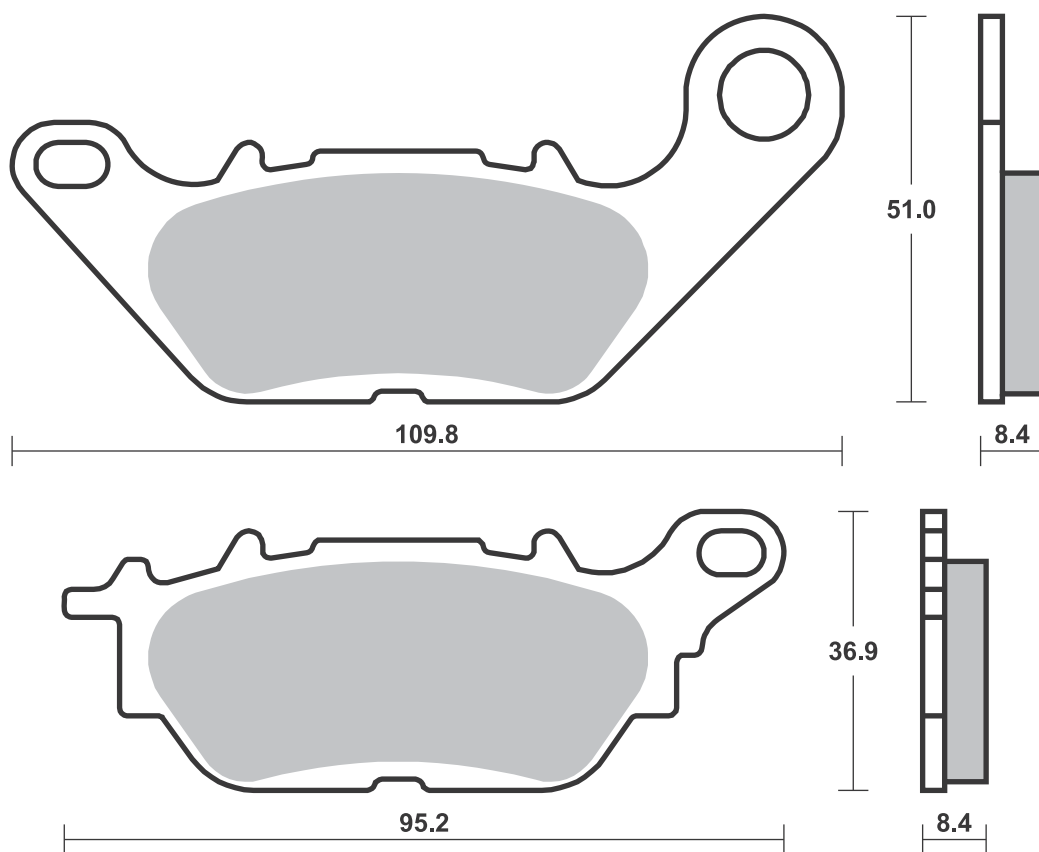
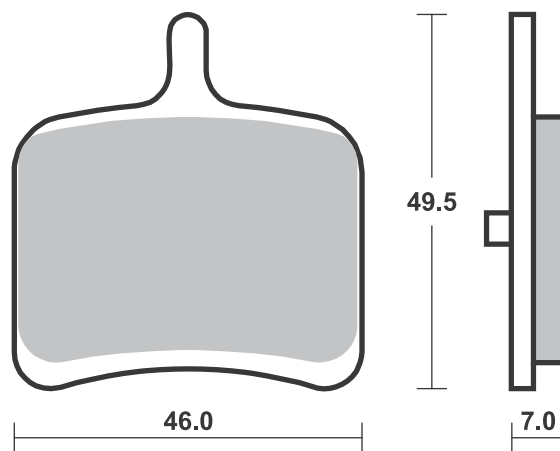



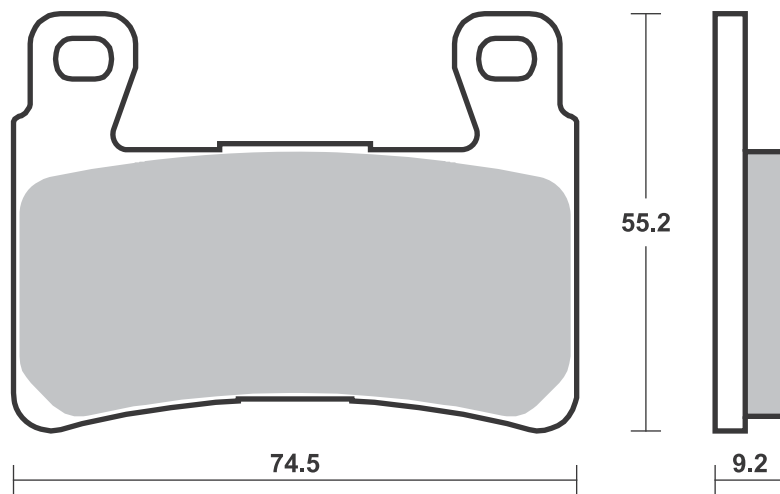
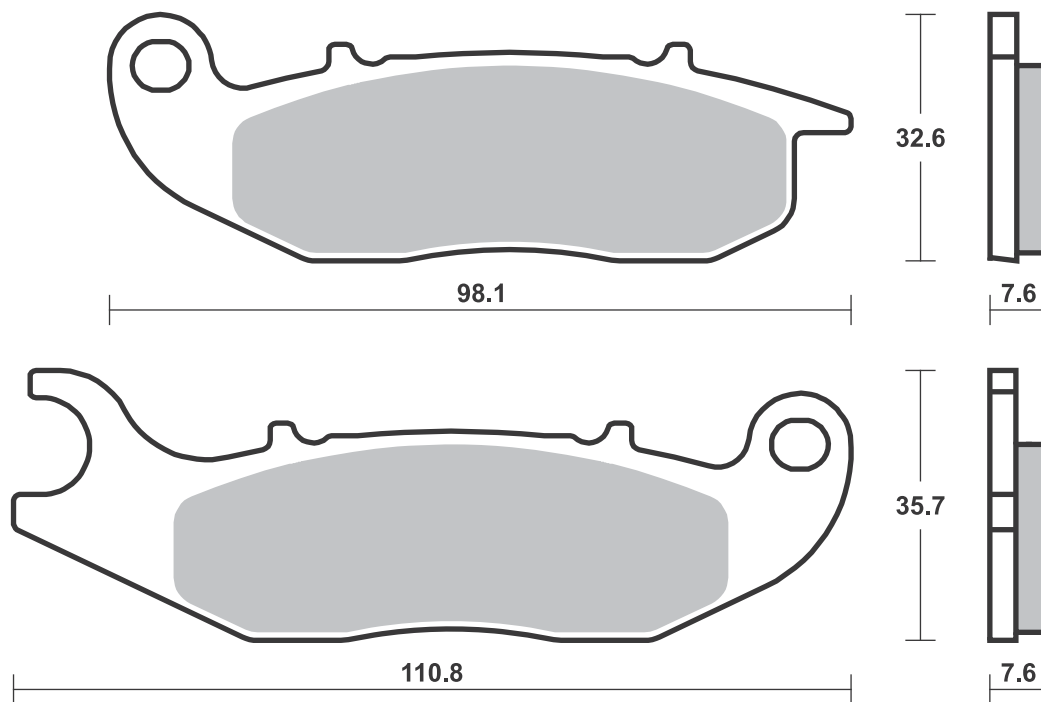



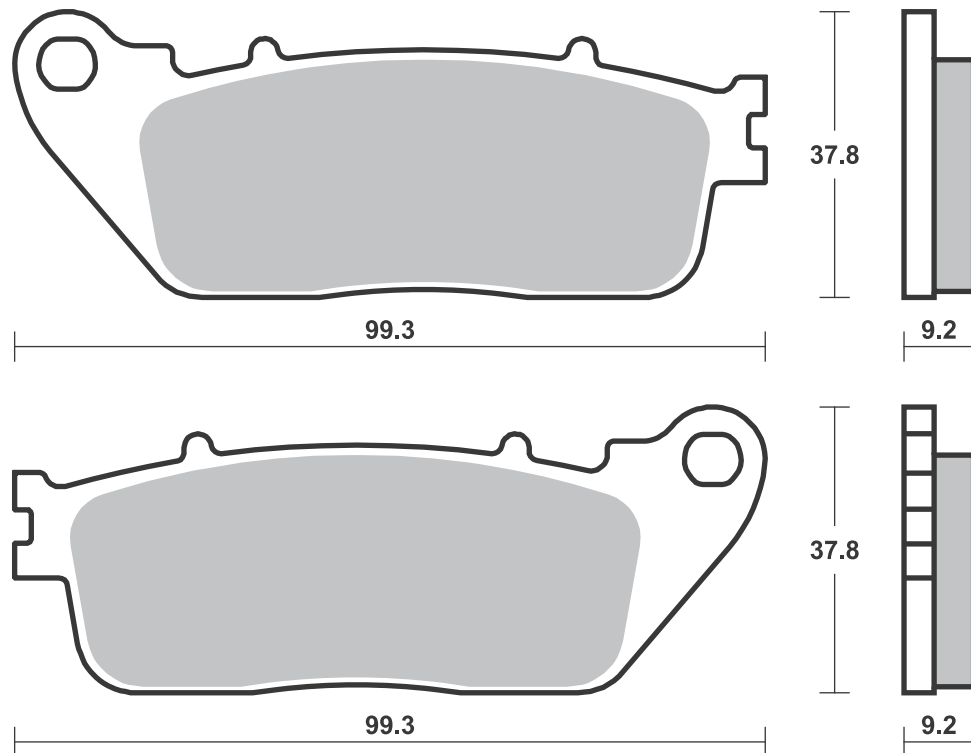
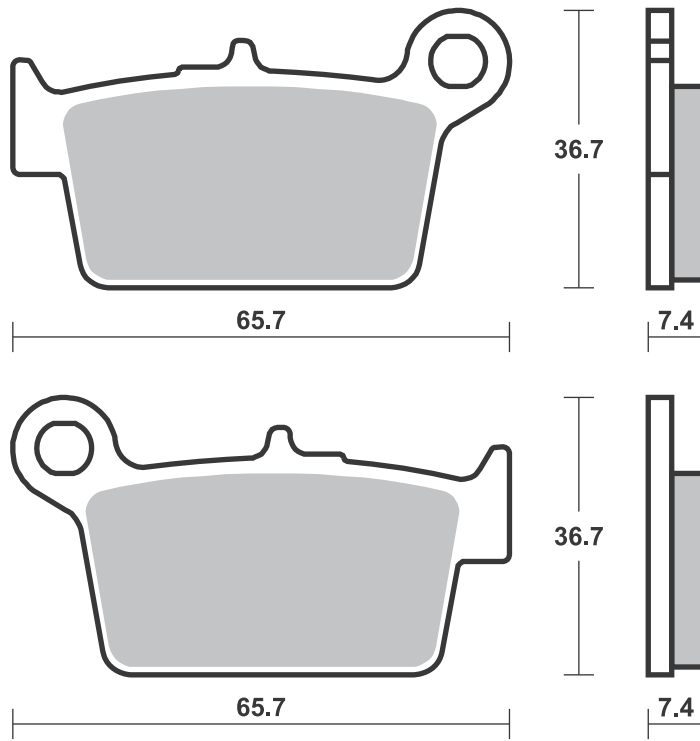



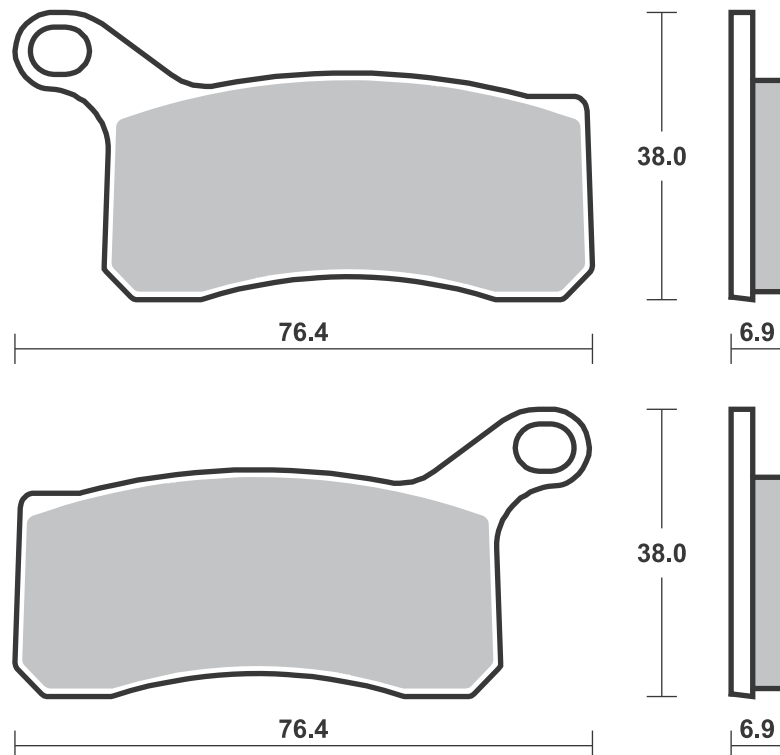
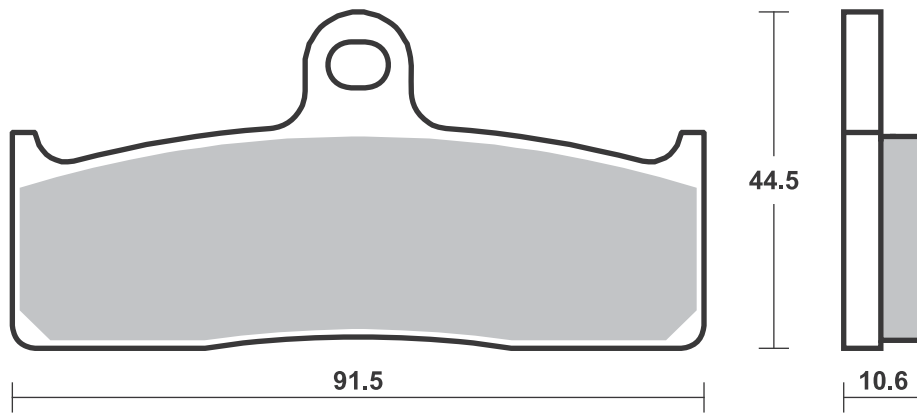
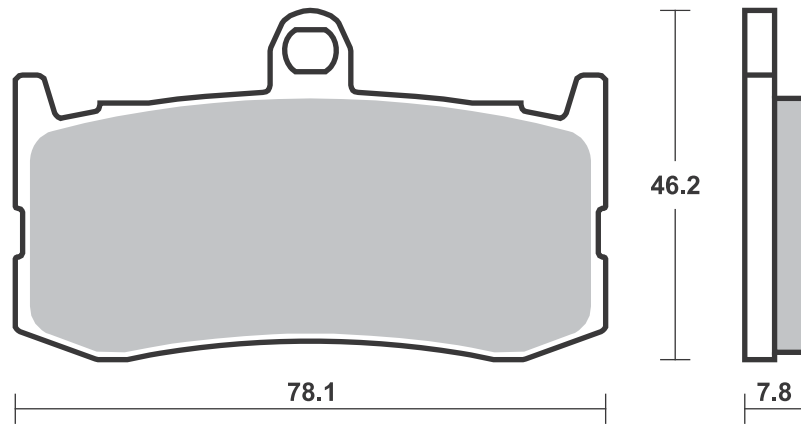





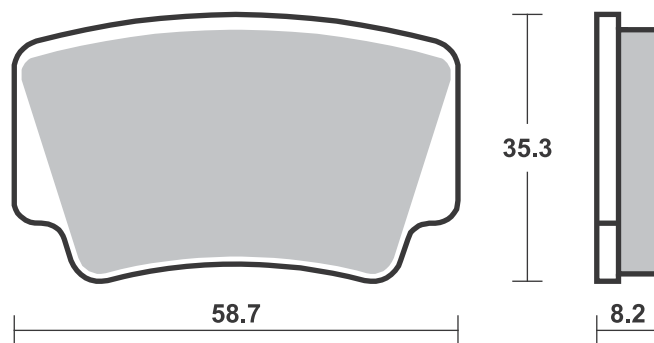

1 set = 2 pcs. large / small

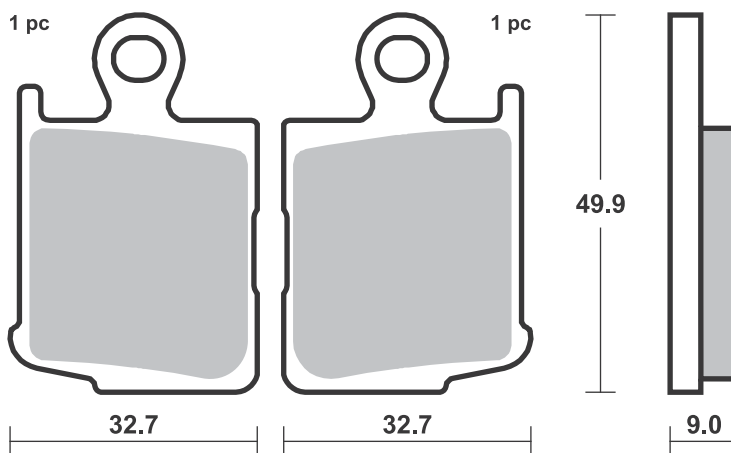
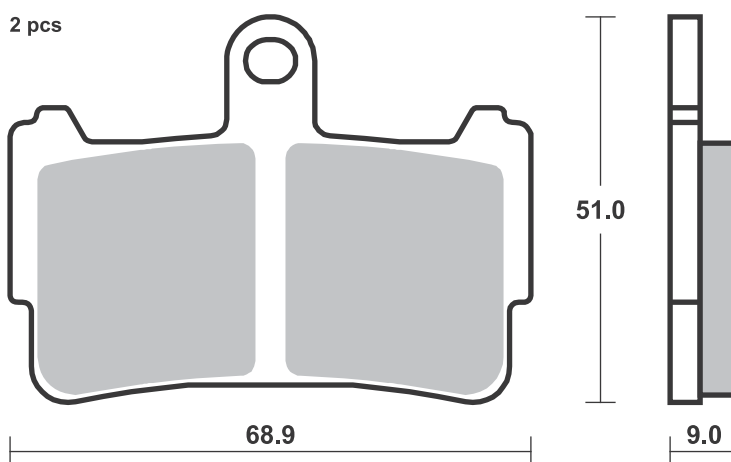



Available compounds

**HS • DC • RS • DS • SP**

**SBS 870**

1 set = 4 pcs.

HS / SP - Th. 8.0  
RS / DC / DS - Th. 8.7

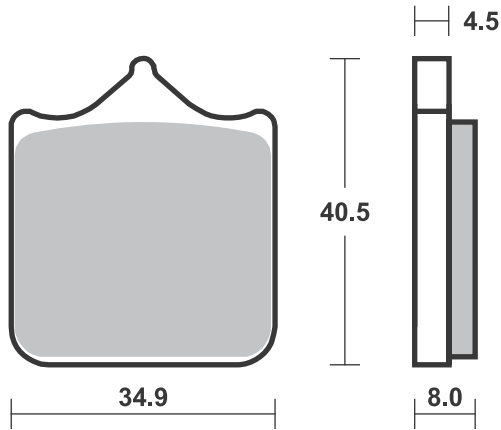

Available compounds

**SI • RSI • CS**

**SBS 872**

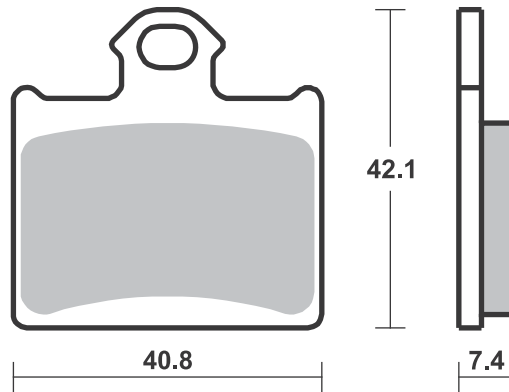

Available compounds

**HF • HS • DC • RS**

**SBS 877**

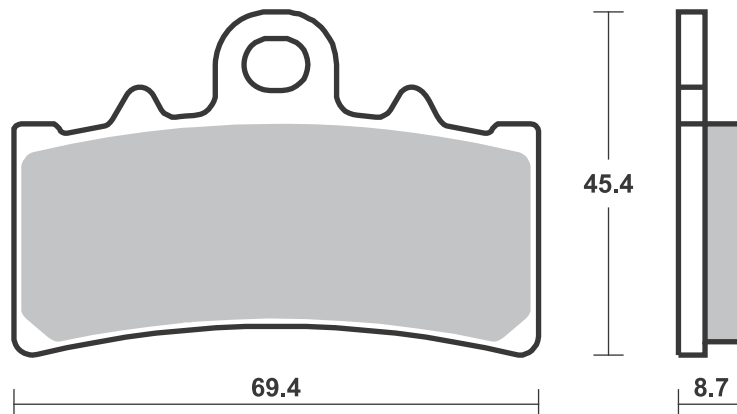



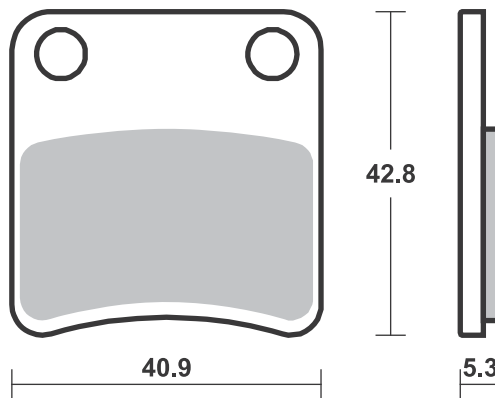
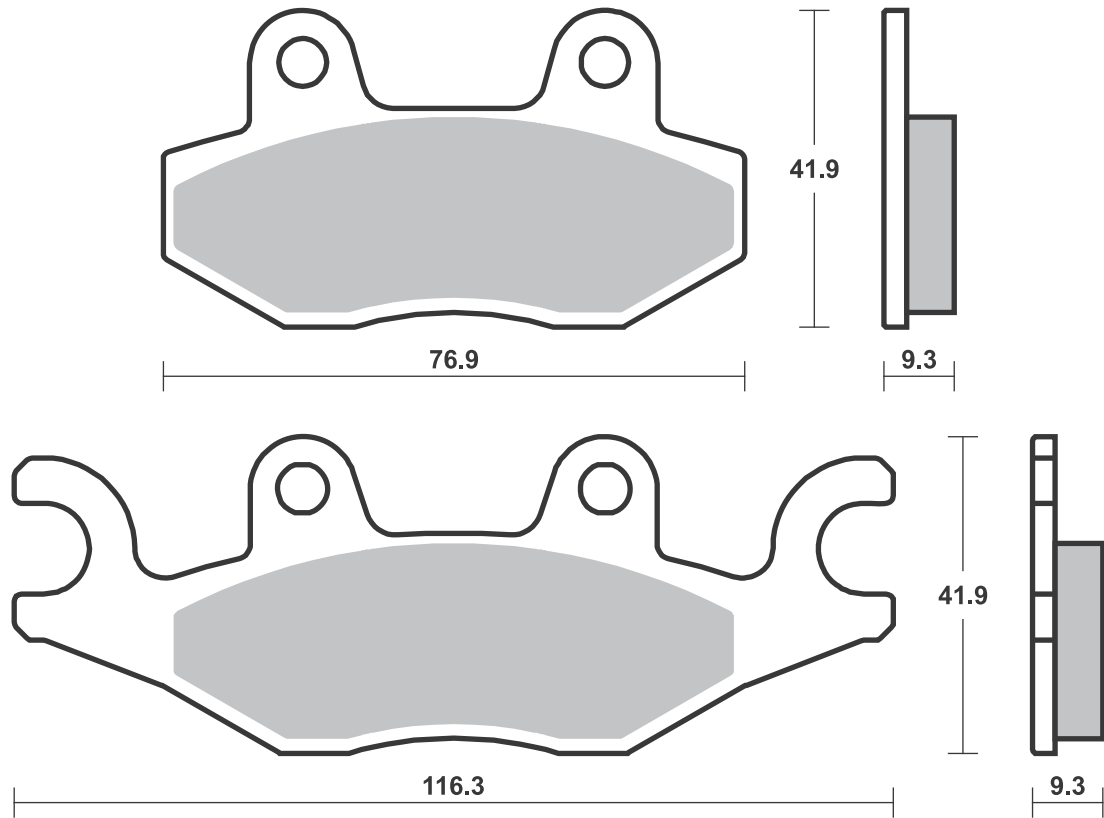



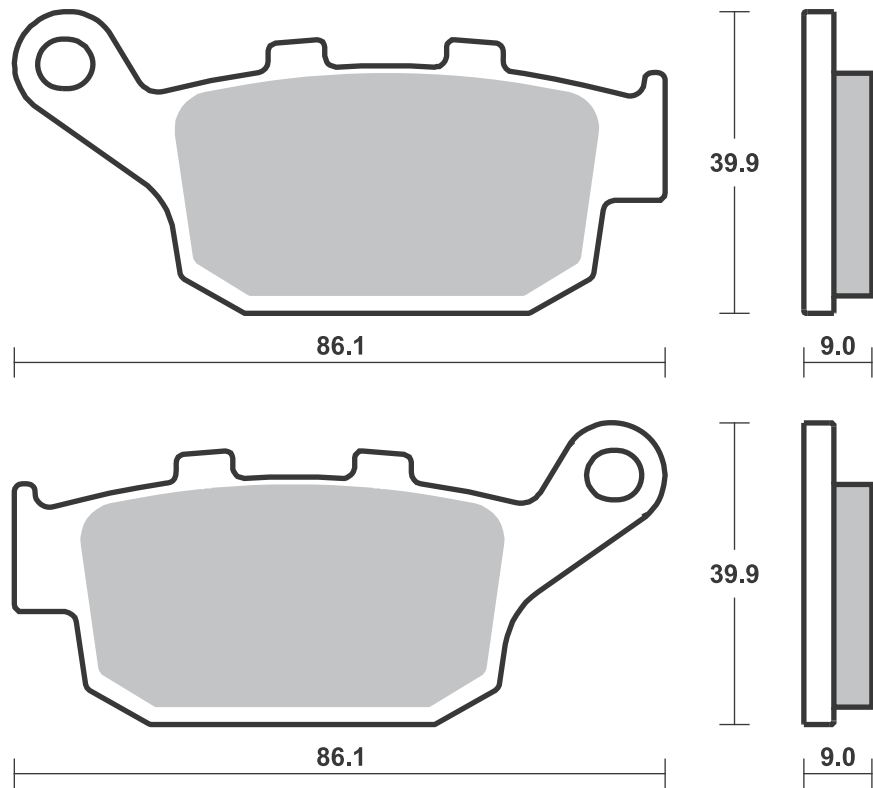
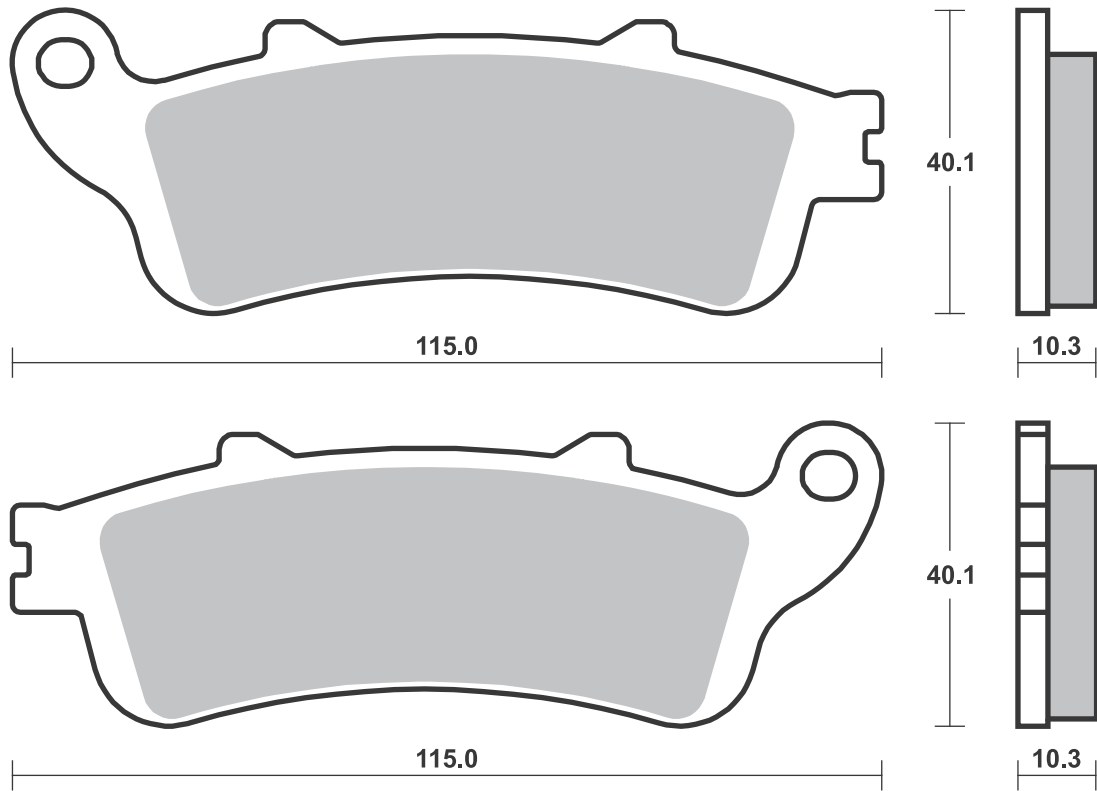

**SBS 885** Recommended compound

<b>GAS GAS</b>			
TXT	125 (Formula cal.)	12-13	<b>RSI</b>
TXT	250 (Formula cal.)	12-13	<b>RSI</b>
TXT	280 (Formula cal.)	12	<b>RSI</b>
TXT	300 (Formula cal.)	12	<b>RSI</b>
<b>HUSQVARNA</b>			
TC	85	14-18	<b>RSI</b>
<b>KTM</b>			
	Freeride		
	Electric	12-14	<b>RSI</b>
E-SM	Freeride	15-16	<b>RSI</b>
E-SX	Freeride	15-16	<b>RSI</b>
E-XC	Freeride	15-18	<b>RSI</b>
SX	85 (19"/16"		
	wheels)	13-18	<b>RSI</b>
SX	85	12-18	<b>RSI</b>
	250 Freeride R	14-18	<b>RSI</b>
	350 Freeride	12-17	<b>RSI</b>
<b>SHERCO</b>			
ST	80 (Formula cal.)	13-14	<b>RSI</b>
ST	125 (Formula cal.)	13-14	<b>RSI</b>
ST	250 (Formula cal.)	13-14	<b>RSI</b>
ST	290 (Formula cal.)	13-14	<b>RSI</b>
ST	305 (Formula cal.)	13-14	<b>RSI</b>

**SBS 886** Recommended compound

<b>KAWASAKI</b>			
VN	900 Vulcan		
	Classic	06-16	<b>LS</b>
VN	900 Vulcan		
	Classic SE	11-16	<b>LS</b>
VN	900 Vulcan		
	Custom	07-16	<b>LS</b>
KZ	1000 Police		
	Left/Rear	02-03	<b>LS</b>
VN	1500 Mean Streak	02-03	<b>LS</b>
VN	1500 Vulcan		
	Classic Fi	00-04	<b>LS</b>
VN	1500 Vulcan		
	Nomad Fi		
	Left/Rear	00-04	<b>LS</b>
VN	1600 Mean Streak	04-05	<b>LS</b>
VN	1600 Nomad		
	Left/Rear	05	<b>LS</b>
VN	1600 Vulcan		
	Classic		
	Left/Rear	03-08	<b>LS</b>
VN	1700 Voyager		
	Vaquero		
	Left/Rear	09-14	<b>LS</b>
VN	1700 Vulcan		
	Classic		
	Left/Rear	09-14	<b>LS</b>
VN	1700 Vulcan		
	Nomad		
	Left/Rear	09-16	<b>LS</b>



<b>KAWASAKI</b>			
VN	1700 Vulcan		
	Voyager	09-16	<b>LS</b>
VN	2000 Vulcan	04-10	<b>LS</b>
<b>SUZUKI</b>			
C	1500 T Intruder	13-18	<b>LS</b>
C90	1500 Boulevard		
	B.O.S.S.	13-18	<b>LS</b>
M90	1500 Left/Rear	09-18	<b>LS</b>
M95	1600 Boulevard	05-07	<b>LS</b>
VZ	1600 Marauder	04	<b>LS</b>



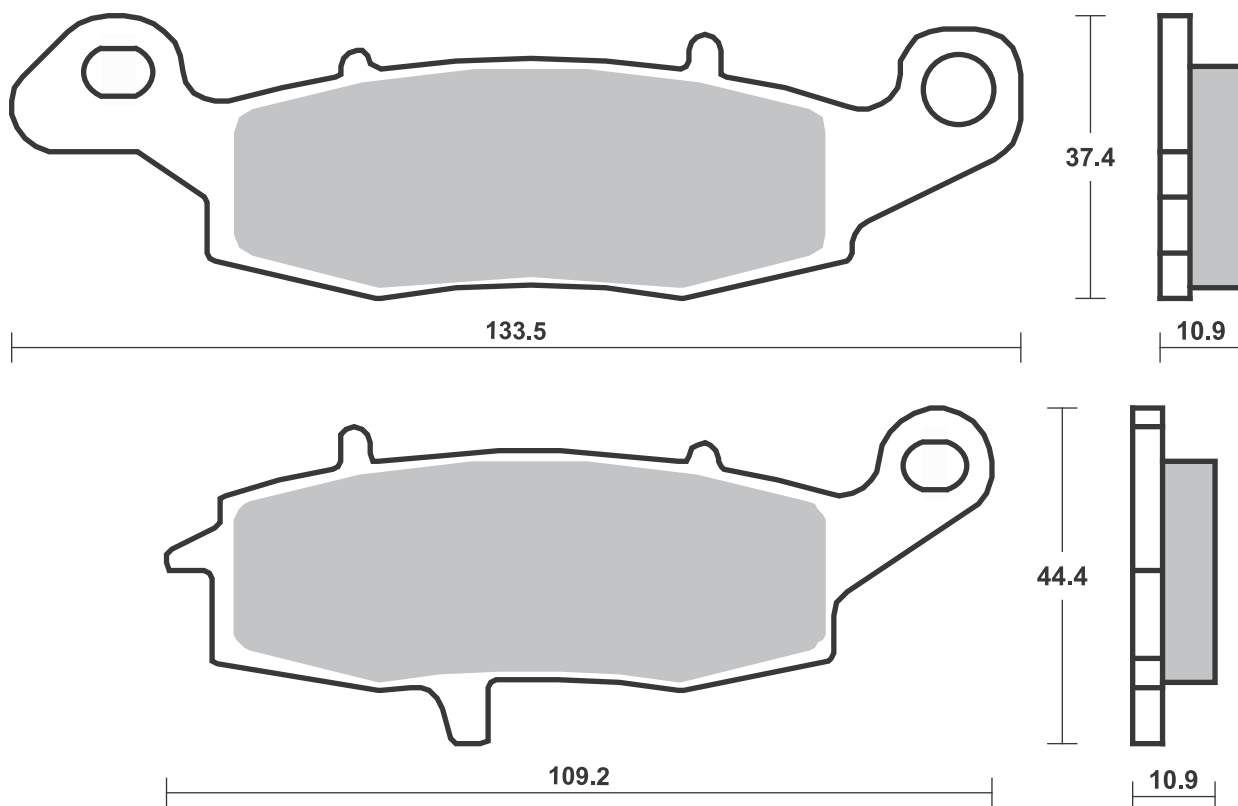
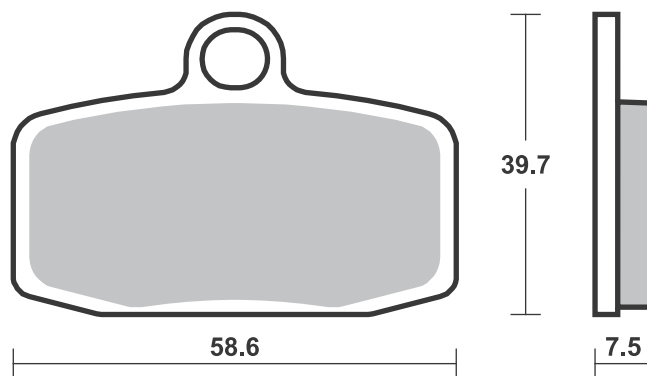



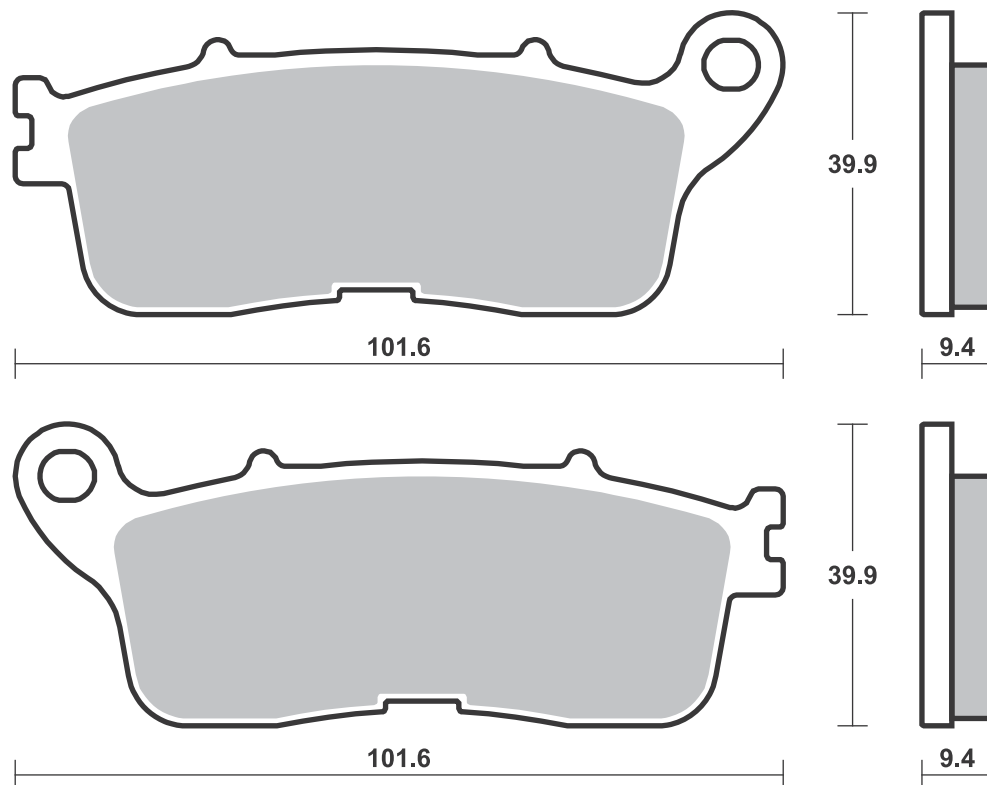
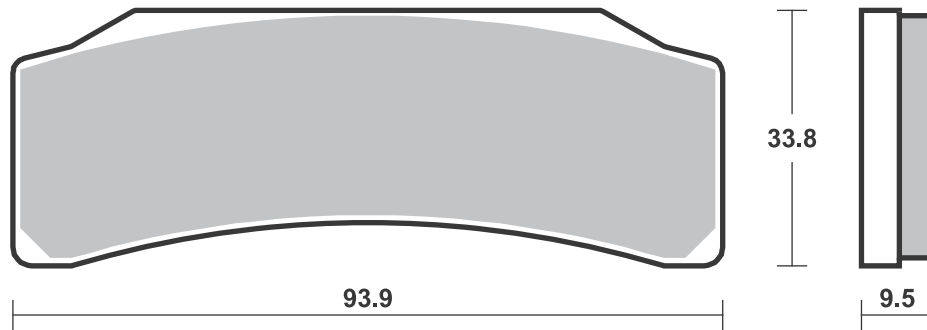
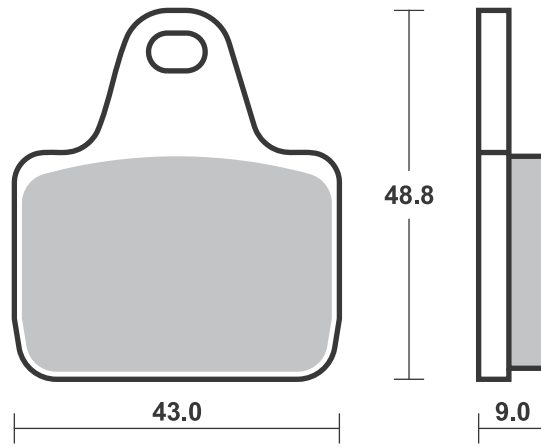



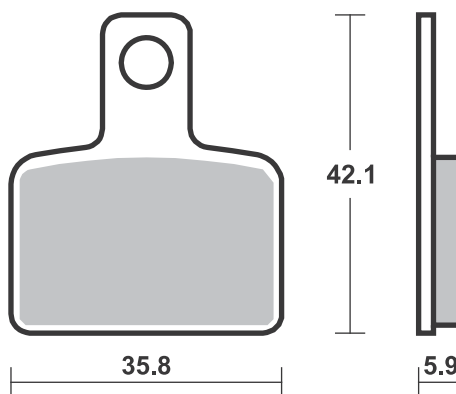
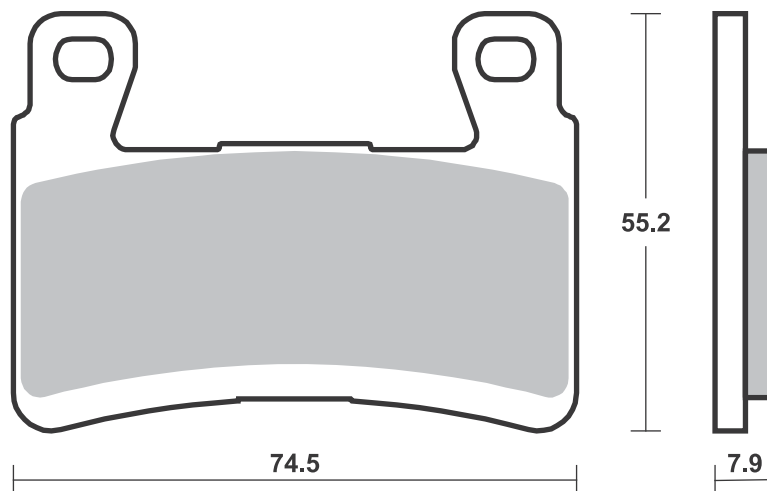
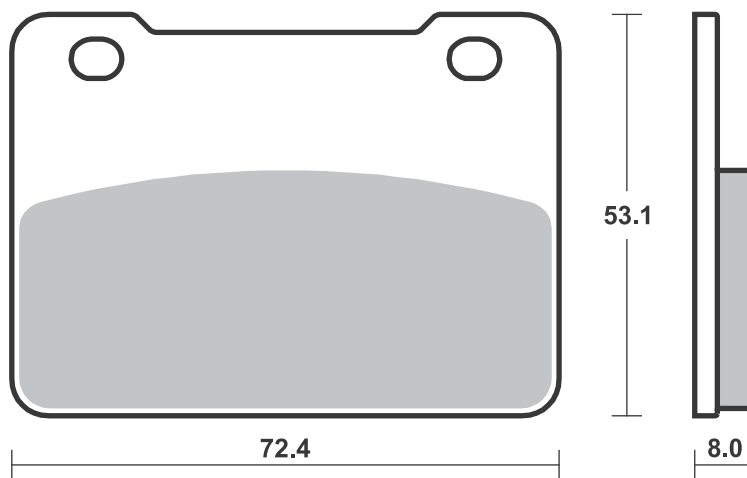



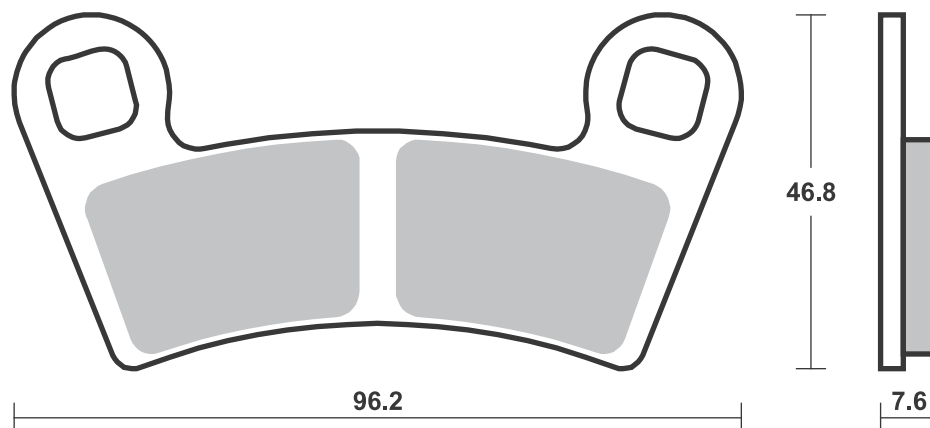
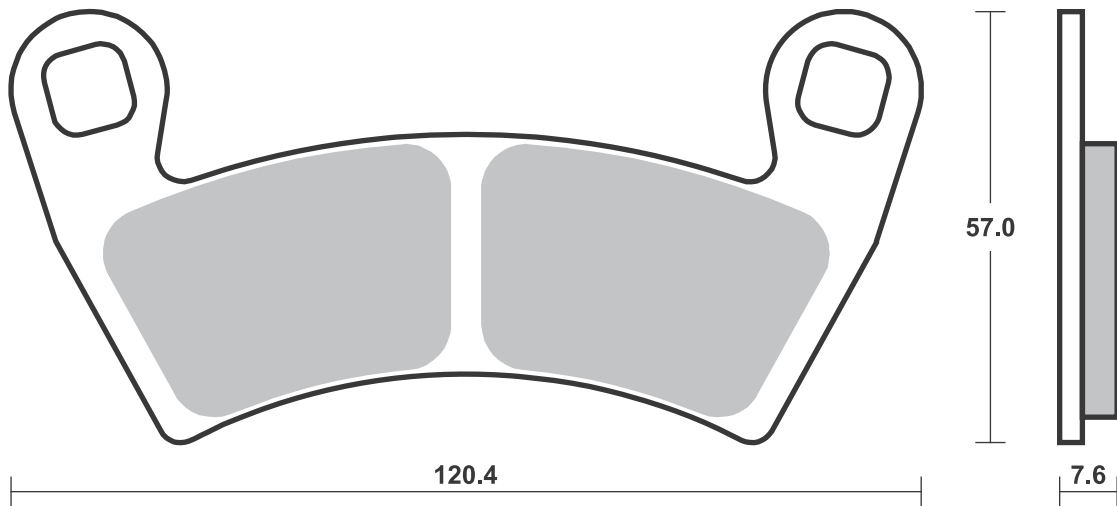
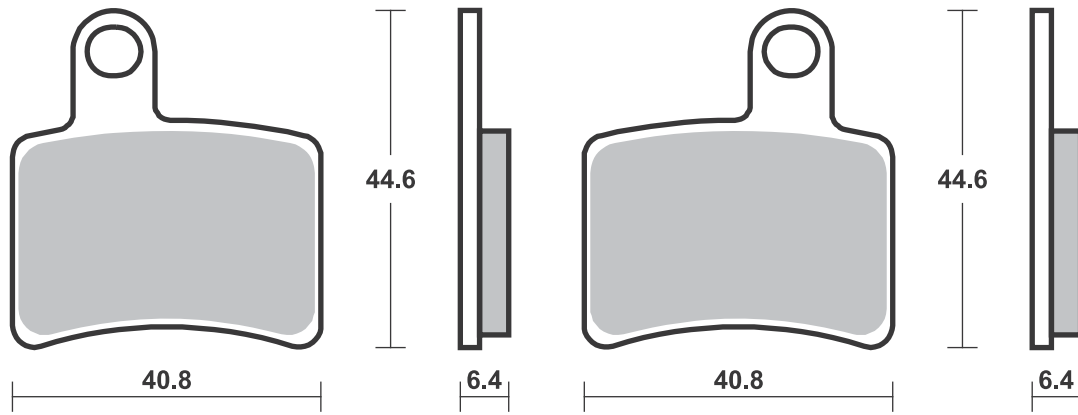

**SBS 899** Recommended compound

<b>POLARIS</b>			
500 Sportsman			
HO (from 16.12.2008)	09-14	<b>ATS</b>	<b>ATS</b>
550 Sportsman	11-14	<b>ATS</b>	<b>ATS</b>
550 Sportsman EPS	10-14	<b>ATS</b>	<b>ATS</b>
550 Sportsman EPS X2	14	<b>ATS</b>	<b>ATS</b>
550 Sportsman Touring EPS	10-12	<b>ATS</b>	<b>ATS</b>
550 Sportsman X2	10-14	<b>ATS</b>	<b>ATS</b>
550 Sportsman XP	09-12	<b>ATS</b>	<b>ATS</b>
550 Sportsman XP EPS	09-14	<b>ATS</b>	<b>ATS</b>
550 Sportsman XP Touring EPS	12-14	<b>ATS</b>	<b>ATS</b>
800 Sportsman (from 16.12.2008)	09-14	<b>ATS</b>	<b>ATS</b>
850 Forest	15	<b>ATS</b>	<b>ATS</b>



<b>POLARIS</b>			
850 Scrambler	15	<b>ATS</b>	<b>ATS</b>
850 Scrambler HO EPS	13-15	<b>ATS</b>	<b>ATS</b>
850 Scrambler MD	15	<b>ATS</b>	<b>ATS</b>
850 Scrambler XP HO EPS	14-15	<b>ATS</b>	<b>ATS</b>
850 Sportsman	11-13	<b>ATS</b>	<b>ATS</b>
850 Sportsman MV	12	<b>ATS</b>	<b>ATS</b>
850 Sportsman Touring	14-15	<b>ATS</b>	<b>ATS</b>
850 Sportsman Touring EPS	10-13	<b>ATS</b>	<b>ATS</b>
850 Sportsman Touring HO EPS	13-14	<b>ATS</b>	<b>ATS</b>
850 Sportsman Touring MD	15	<b>ATS</b>	<b>ATS</b>
850 Sportsman X2	11	<b>ATS</b>	<b>ATS</b>
850 Sportsman XP	09-14	<b>ATS</b>	<b>ATS</b>



<b>POLARIS</b>			
850 Sportsman XP EPS	09-14	<b>ATS</b>	<b>ATS</b>
850 Sportsman XP HO EPS	13-14	<b>ATS</b>	<b>ATS</b>
850 Sportsman MD	15	<b>ATS</b>	<b>ATS</b>
850 Sportsman XP Touring EPS	15	<b>ATS</b>	<b>ATS</b>
1000 Forest	15	<b>ATS</b>	<b>ATS</b>
1000 Scrambler MD	15-18	<b>ATS</b>	<b>ATS</b>
1000 Scrambler XP	15-18	<b>ATS</b>	<b>ATS</b>
1000 Scrambler XP HO EPS	14	<b>ATS</b>	<b>ATS</b>
1000 Sportsman MD	15-18	<b>ATS</b>	<b>ATS</b>
1000 Sportsman Touring	15-18	<b>ATS</b>	<b>ATS</b>
1000 Sportsman XP	15-18	<b>ATS</b>	<b>ATS</b>

**SBS 900** Recommended compound

<b>APRILIA</b>			
RSV 1000 Tuono V4 R	14	<b>HS</b>	
RSV 1100 Tuono V4	15	<b>HS</b>	
RSV 1100 Tuono V4 Factory	16-18	<b>HS</b>	
RSV 1100 Tuono V4 RR	15-18	<b>HS</b>	
1200 Caponord	13-18	<b>SP</b>	
1200 Caponord Rally	15-18	<b>SP</b>	
1200 Caponord Travel Pack	16-18	<b>SP</b>	
<b>BMW</b>			
F 800 R	15-18	<b>HS</b>	
S 1000 XR	15-18	<b>SP</b>	
R 1200 GS	13-18	<b>SP</b>	
R 1200 GS Adventure	14-16	<b>SP</b>	
R 1200 Nine-T	14-18	<b>HS</b>	
R 1200 R	15-18	<b>HS</b>	
R 1200 RS	14-18	<b>HS</b>	
R 1200 RT	14-18	<b>HS</b>	
<b>CAN-AM</b>			
1330 Spyder F3	15-18	<b>HS</b>	
1330 Spyder F3 Limited	16-18	<b>HS</b>	
1330 Spyder F3-S	15-18	<b>HS</b>	
1330 Spyder F3-T	16-18	<b>HS</b>	
1330 Spyder RS	14-16	<b>HS</b>	
1330 Spyder RS RSS 13		<b>HS</b>	
1330 Spyder RSS	14-15	<b>HS</b>	
1330 Spyder RSS Special Series	15	<b>HS</b>	
1330 Spyder RT	14-18	<b>HS</b>	
1330 Spyder RT Limited	13-18	<b>HS</b>	
1330 Spyder RT RTS	13	<b>HS</b>	
1330 Spyder RTS	14-15	<b>HS</b>	



<b>CAN-AM</b>			
1330 Spyder RTS Special Series	15	<b>HS</b>	
1330 Spyder ST	14-16	<b>HS</b>	
1330 Spyder ST Limited	13-15	<b>HS</b>	
1330 Spyder ST STS	13	<b>HS</b>	
1330 Spyder STS	14-15	<b>HS</b>	
1330 Spyder STS Special Series	15	<b>HS</b>	
<b>DUCATI</b>			
797 Monster	17-18	<b>HS</b>	
797 Monster+	17-18	<b>HS</b>	
800 Hypermotard	13-15	<b>HS</b>	
800 Hypermotard ABS	13-15	<b>HS</b>	
800 Hypermotard SP	13-15	<b>HS</b>	
800 Hypermotard SP ABS	13-15	<b>HS</b>	
800 Hyperstrada	13-15	<b>HS</b>	
800 Hyperstrada ABS	13-15	<b>HS</b>	
800 Scrambler	17-18	<b>HS</b>	
800 Scrambler Classic	15-18	<b>HS</b>	
800 Scrambler CR	17-18	<b>HS</b>	
800 Scrambler CR Cafe Racer	17-18	<b>HS</b>	
800 Scrambler Enduro	15-16	<b>HS</b>	
800 Scrambler Flat Track Pro	16	<b>HS</b>	
800 Scrambler Full Throttle	15-18	<b>HS</b>	
800 Scrambler Icon	15-18	<b>HS</b>	



<b>DUCATI</b>			
800 Scrambler Mach 2.0	18-	<b>HS</b>	
800 Scrambler Street Classic	17-18	<b>HS</b>	
800 Scrambler Urban Enduro	16	<b>HS</b>	
800 Scrambler-X DS Desert Sled	17-18	<b>HS</b>	
821 Monster	14-18	<b>HS</b>	
821 Monster Dark	15-16	<b>HS</b>	
899 Panigale	14-15	<b>HS</b>	
939 Hypermotard	16-18	<b>HS</b>	
939 Hypermotard SP	16-18	<b>HS</b>	
939 Hyperstrada	16	<b>HS</b>	
939 SuperSport	17-18	<b>HS</b>	
939 SuperSport S	17-18	<b>HS</b>	
950 Multistrada	17-18	<b>HS</b>	
959 Panigale	16-18	<b>HS</b>	
959 Panigale Corse	18-	<b>HS</b>	
1100 Scrambler	18-	<b>HS</b>	
1100 Scrambler Special	18-	<b>HS</b>	
1100 Scrambler Sport	18-	<b>HS</b>	
1200 Monster	14-18	<b>HS</b>	
1200 Multistrada	15-16	<b>SP</b>	
1200 Multistrada Enduro	16-18	<b>SP</b>	
1200 Multistrada Enduro Pro	18-	<b>SP</b>	
<b>FANTIC</b>			
500 Caballero	17	<b>HS</b>	



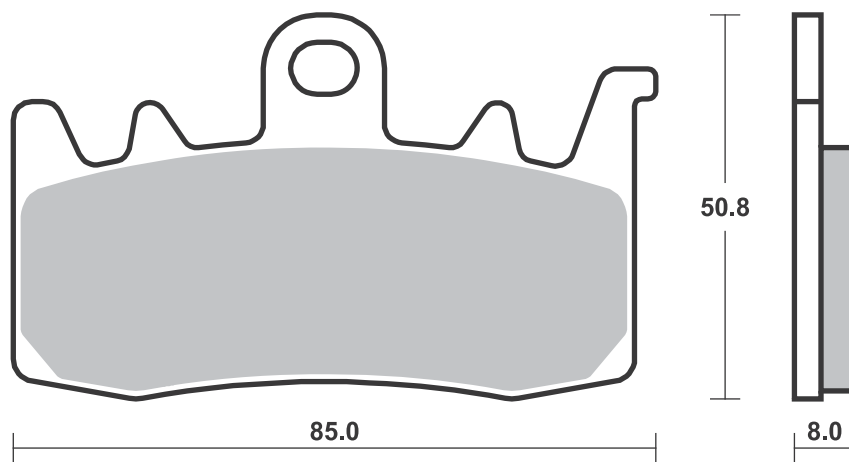
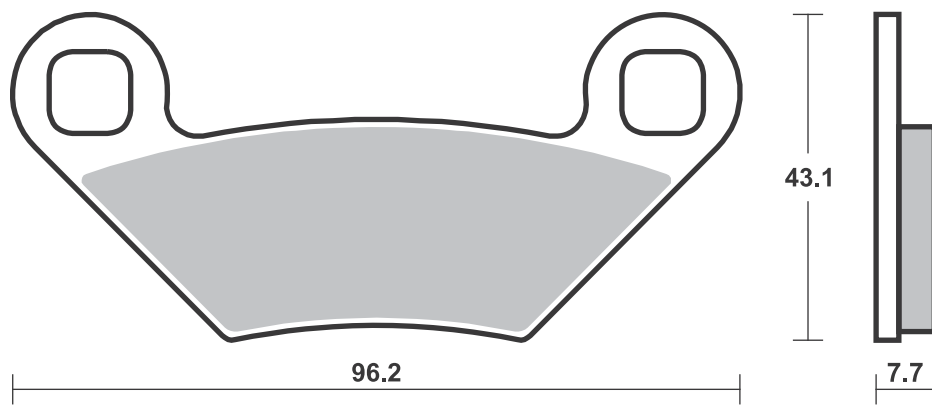

**SBS 900** Recommended compound

<b>MV AGUSTA</b>			
800 Rivale	13-17	<b>HS</b>	
800 Stradale	15-16	<b>HS</b>	
800 Turismo			
Veloce	14-16	<b>HS</b>	
800 Turismo			
Veloce			
Lusso	14-16	<b>HS</b>	
800 Turismo			
Veloce RC	17-18	<b>HS</b>	

**NORTON**

961 Commando			
Cafe Racer			
MKII	18-	<b>HS</b>	
961 Commando			
Sport	18-	<b>HS</b>	
961 Dominator			
Naked	17-18	<b>HS</b>	

**TRIUMPH**

765 Street			
Triple R	17-18	<b>HS</b>	
765 Street			
Triple R			
Low	17-18	<b>HS</b>	
1200 Tiger			
Explorer	16-17	<b>SP</b>	
1200 Tiger XCA	18-	<b>SP</b>	
1200 Tiger XCX	18-	<b>SP</b>	
1200 Tiger XR	18-	<b>SP</b>	



<b>TRIUMPH</b>			
1200 Tiger XRT	18-	<b>SP</b>	
1200 Tiger XRX	18-	<b>SP</b>	
1200 Tiger XRX			
Low	18-	<b>SP</b>	

**SBS 901** Recommended compound

<b>APRILIA</b>			
RSV4-RF 1000	15-18	<b>SP</b>	
RSV4-RR 1000	15-18	<b>SP</b>	

**BIMOTA**

BB3 1000	14-18	<b>SP</b>	
DB7 1099	09	<b>HS</b>	
DB8 1198	10-14	<b>SP</b>	
DB11 1200 VLX	13	<b>HS</b>	

**BMW**

S 1000 RR HP4	12-14	<b>SP</b>	
1200 HP2			
Sport	08-10	<b>SP</b>	

**DUCATI**

1200 Diavel	11-18	<b>HS</b>	
1200 Diavel			
Strada	11-14	<b>HS</b>	
1200 Xdiavel	16-18	<b>HS</b>	
1200 Xdiavel S	16-18	<b>HS</b>	

**HONDA**

CBR 1000 RR SP	14-18	<b>SP</b>	
CBR 1000 RR SP2	17-18	<b>SP</b>	
RC213V-S 1000	16-18	<b>SP</b>	

**KTM**

1290 Super			
Duke GT	16-18	<b>HS</b>	



<b>MOTO-MORINI</b>			
1200 Corsaro ZZ	18-	<b>HS</b>	
1200 Milano	18-	<b>HS</b>	
1200 Scrambler	18-	<b>HS</b>	

**MV AGUSTA**

675 F3	15-17	<b>HS</b>	
675 F3 RC	16-17	<b>HS</b>	
800 F3	14-17	<b>HS</b>	
800 F3 RC	16-17	<b>HS</b>	

**TRIUMPH**

675 Daytona			
R Triple	11-18	<b>HS</b>	
765 Street			
Triple RS	17-18	<b>HS</b>	
1050 Speed			
94R	15-16	<b>HS</b>	
1050 Speed			
Triple	16-17	<b>HS</b>	
1050 Speed			
Triple R	12-18	<b>HS</b>	
1050 Speed			
Triple S	16-18	<b>HS</b>	
1200 Thruxton			
R	16-18	<b>HS</b>	

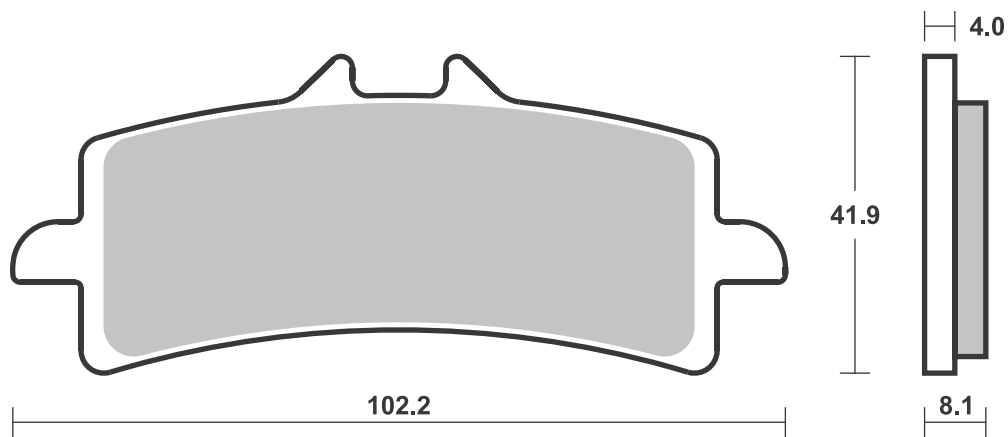
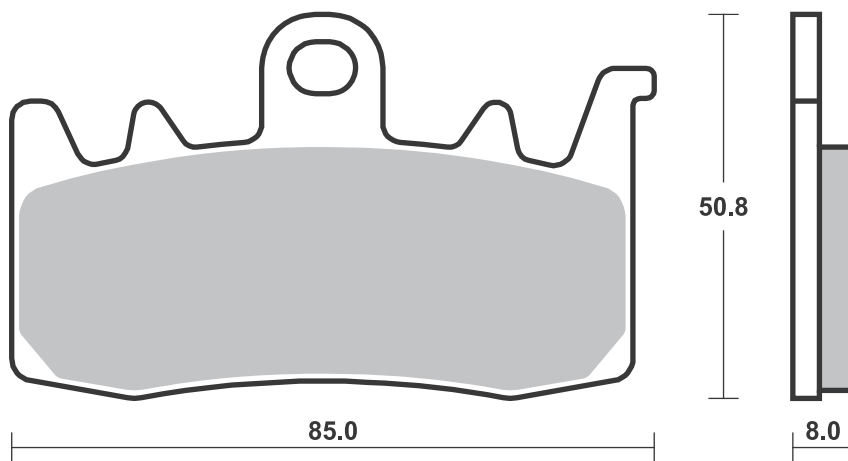



1 set = 4 pcs.

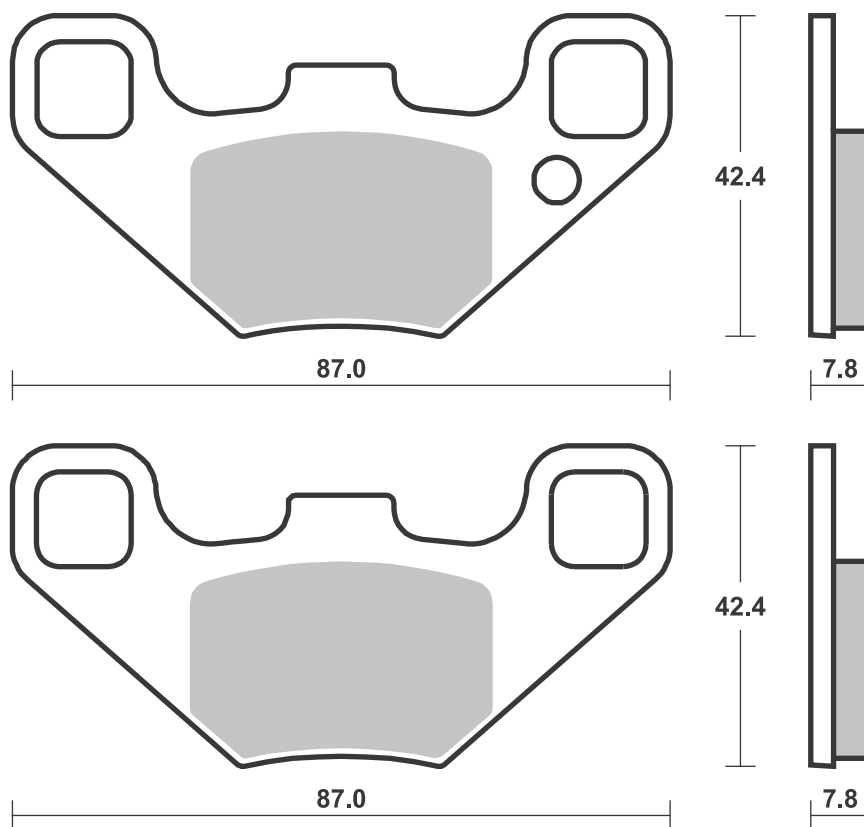
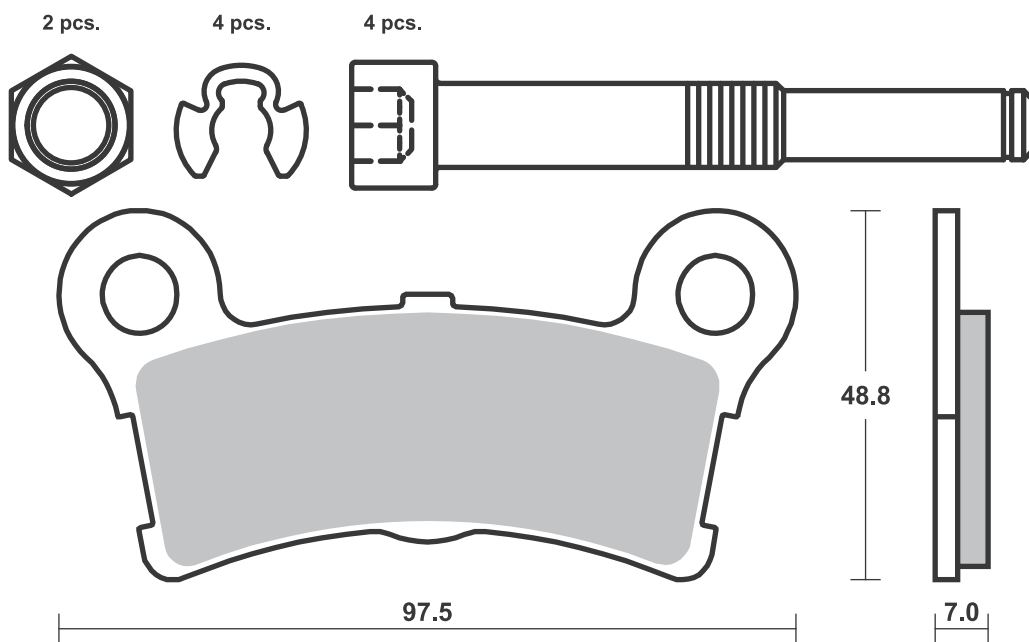



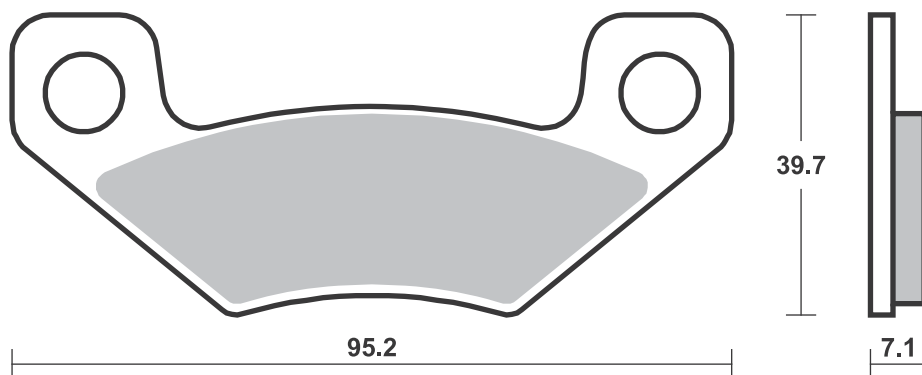
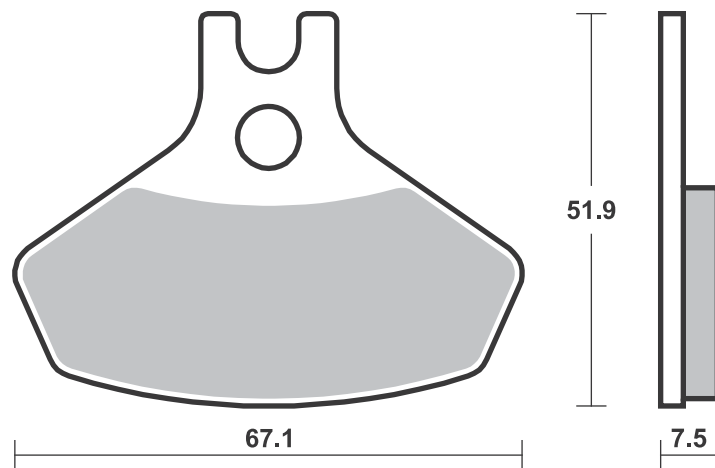
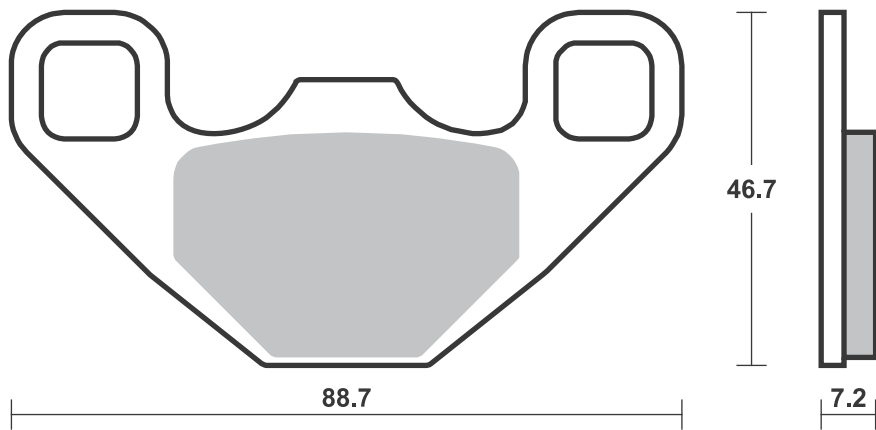





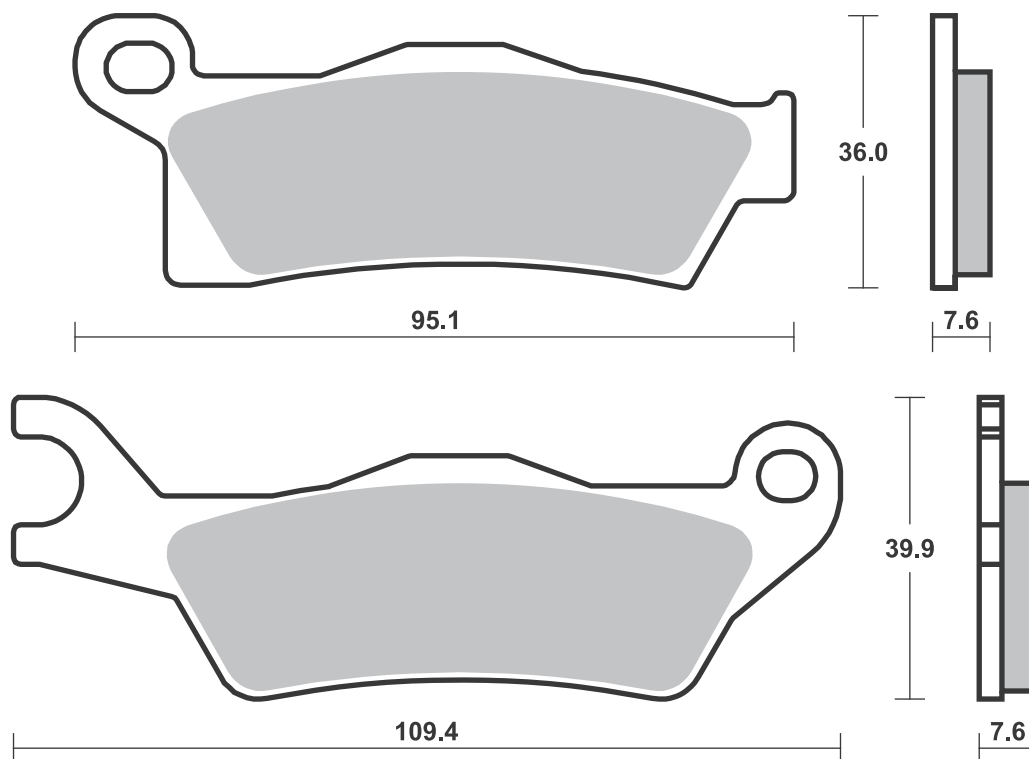
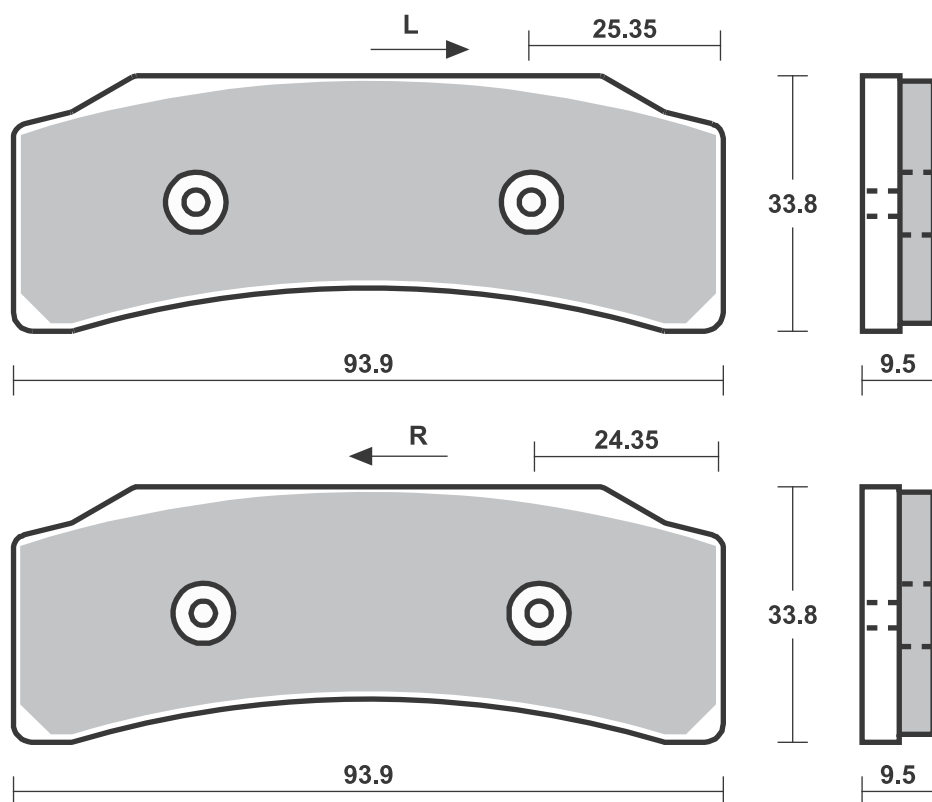



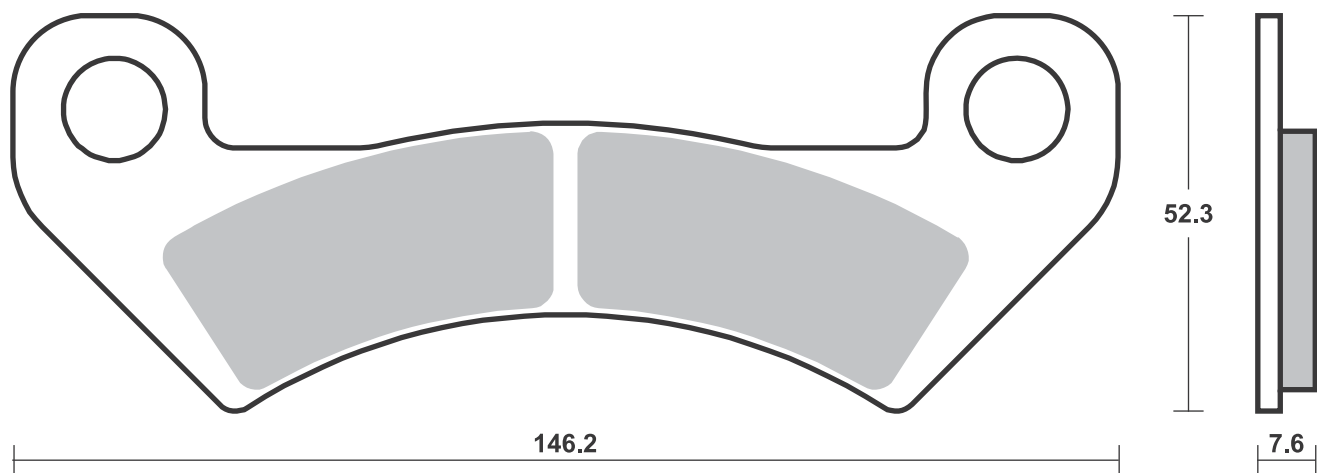
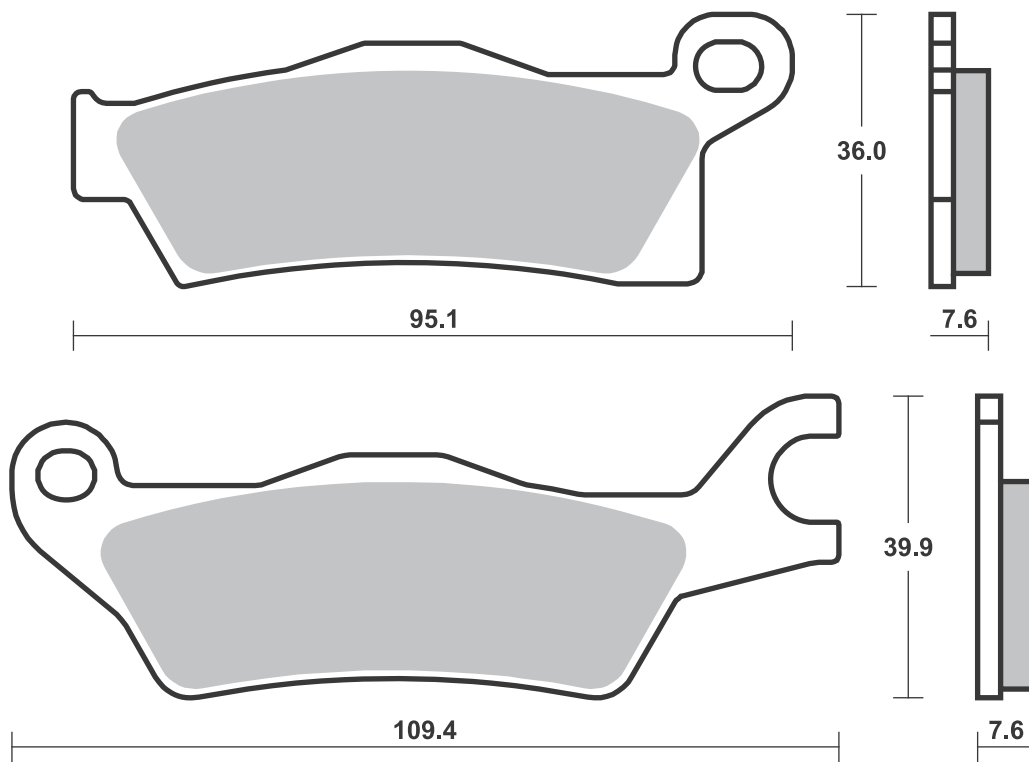



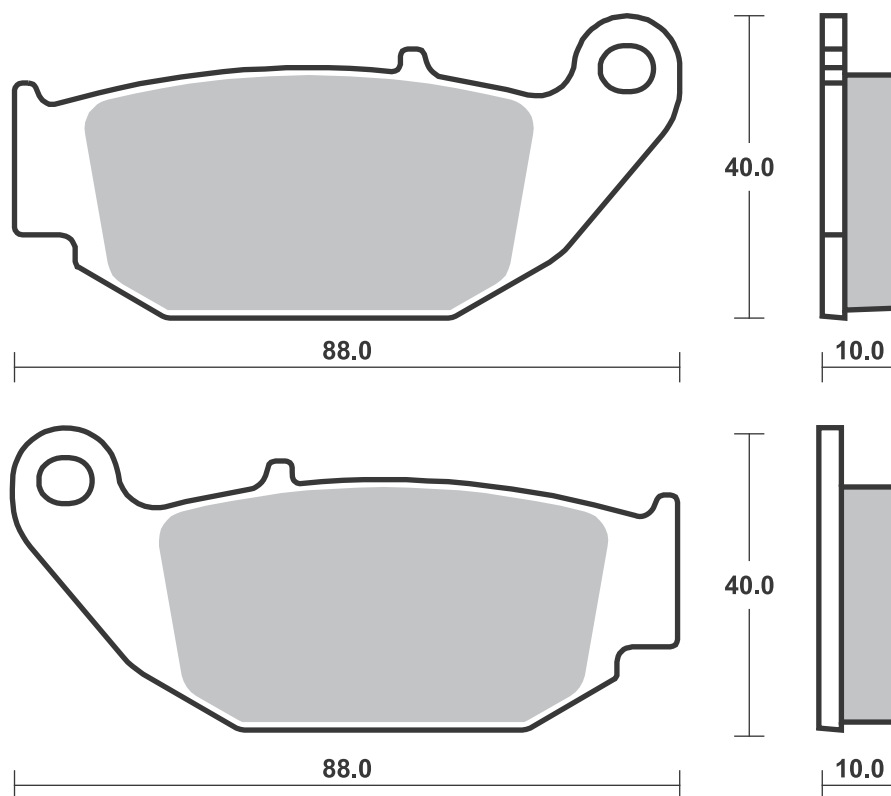
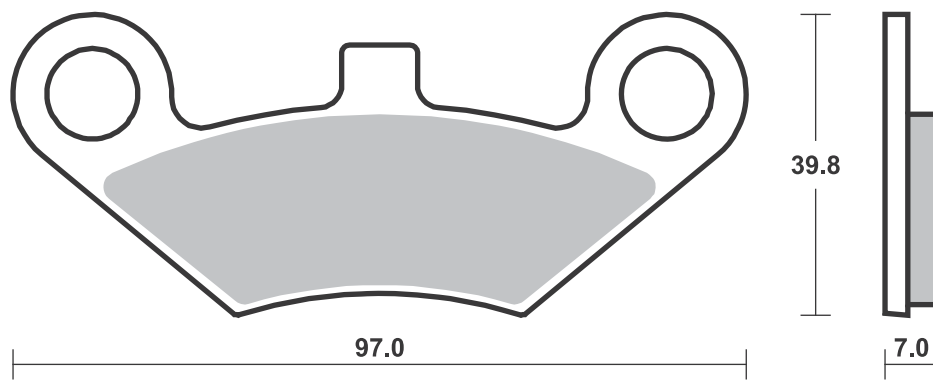



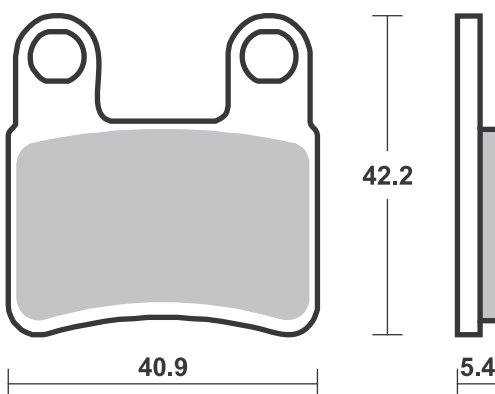
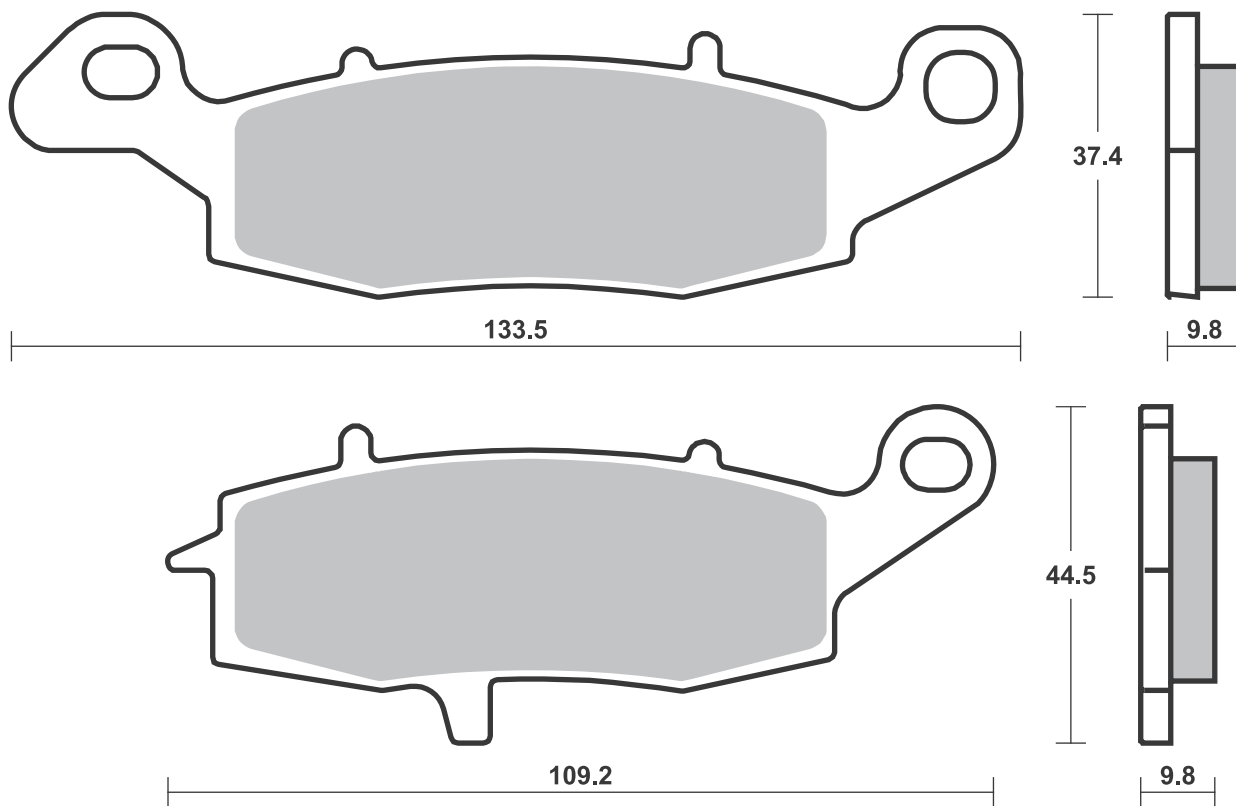





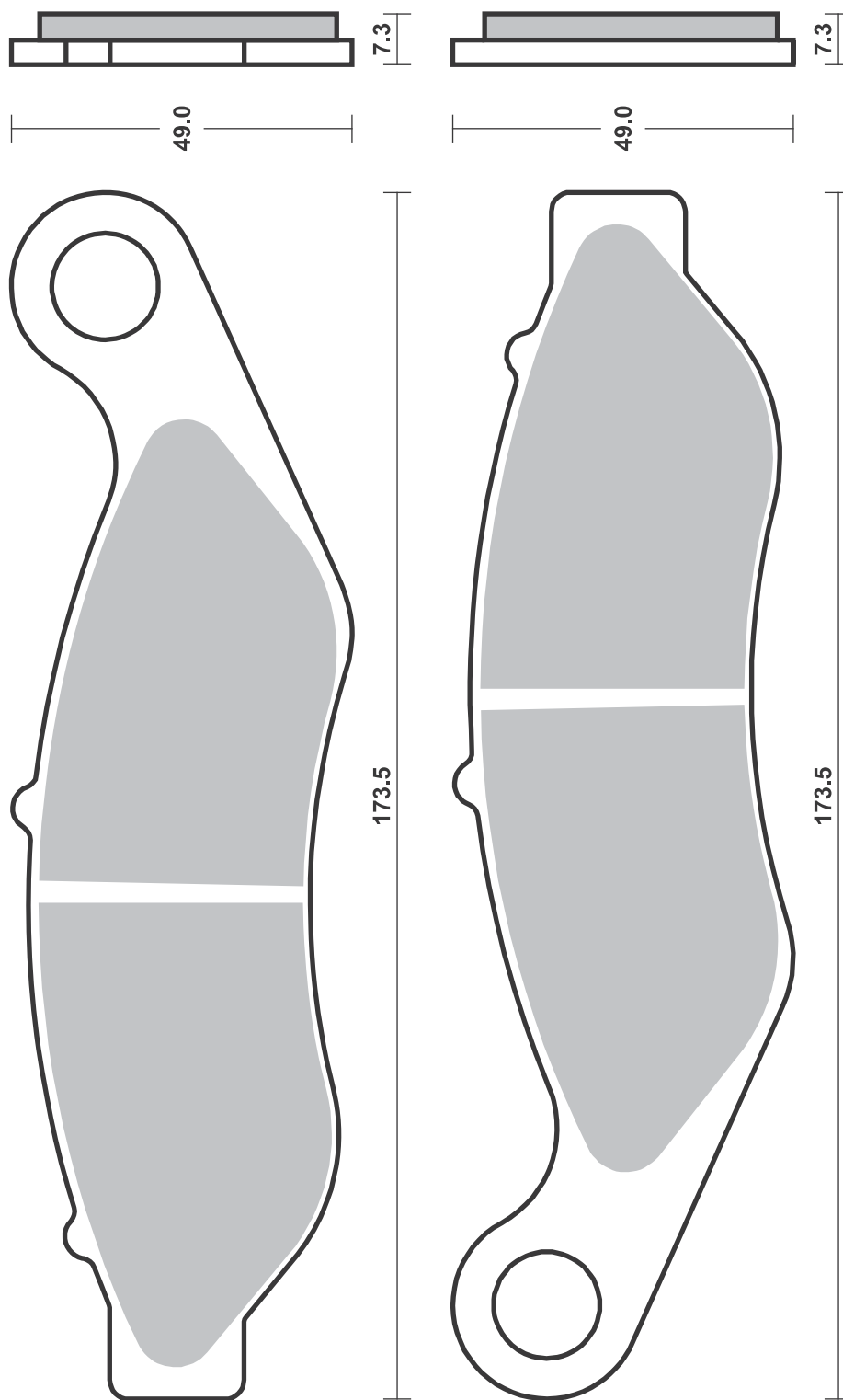



1 set = 4 pcs.

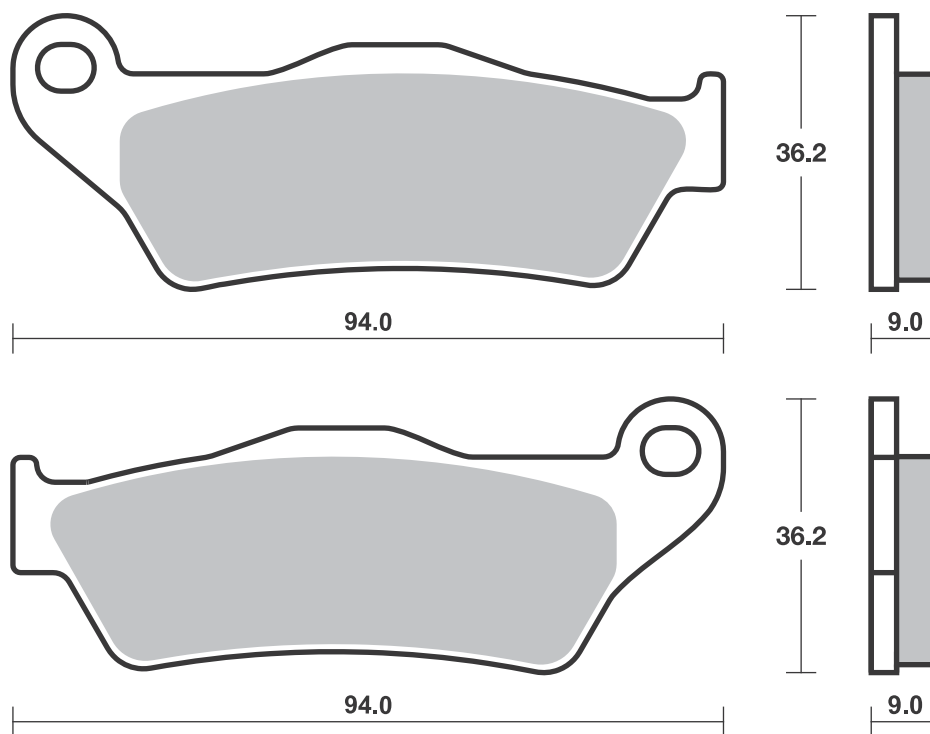
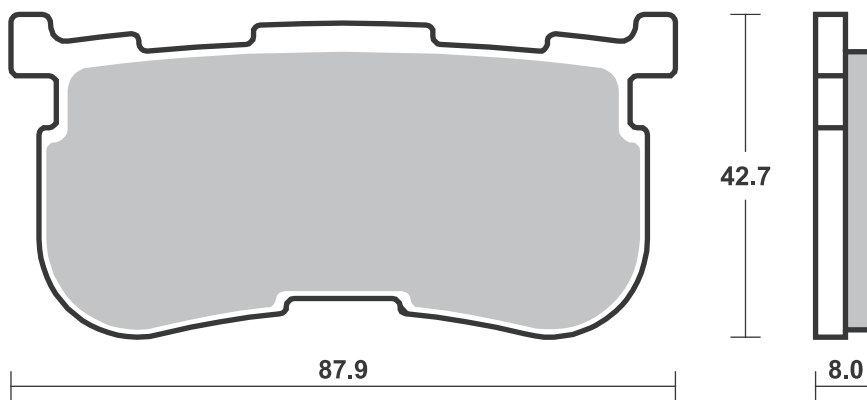



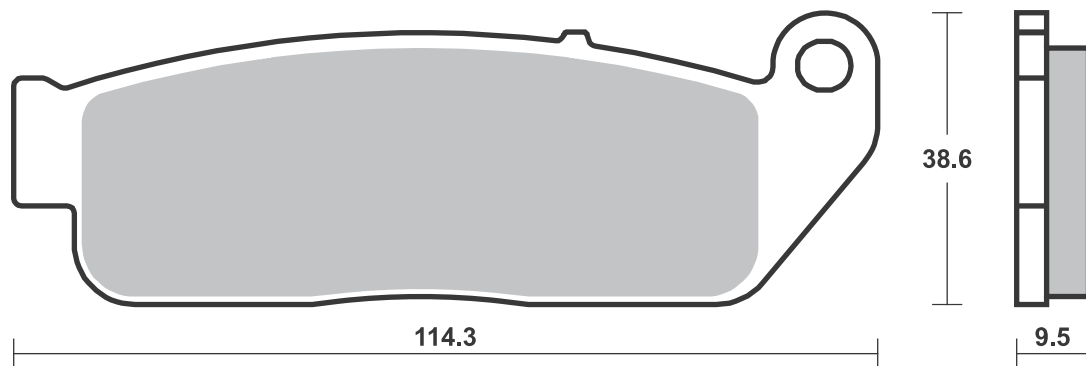
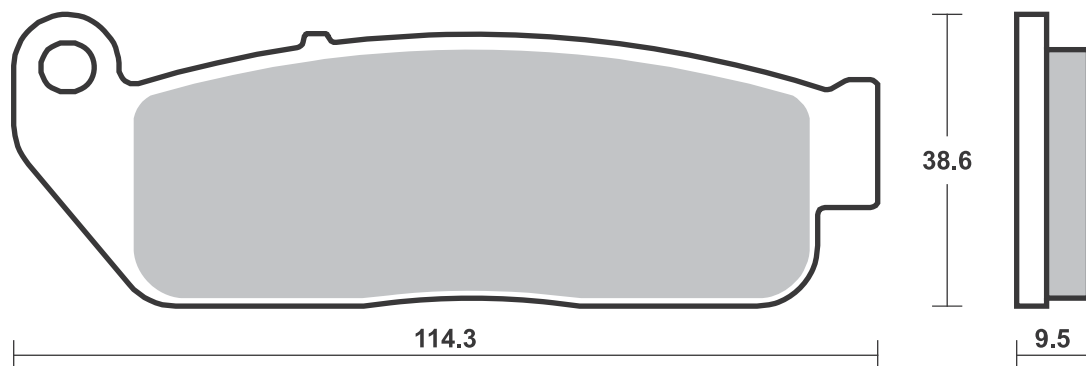
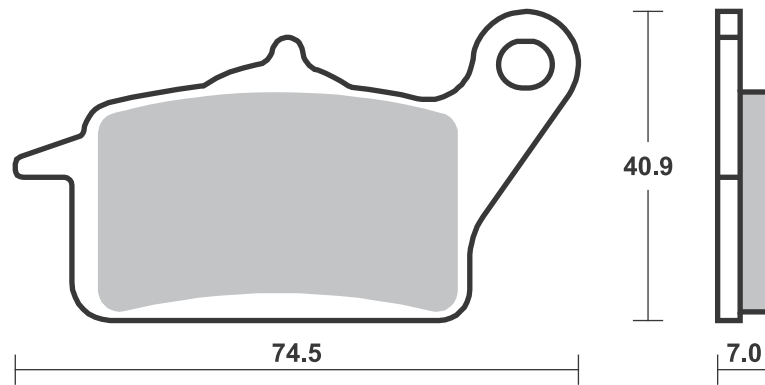
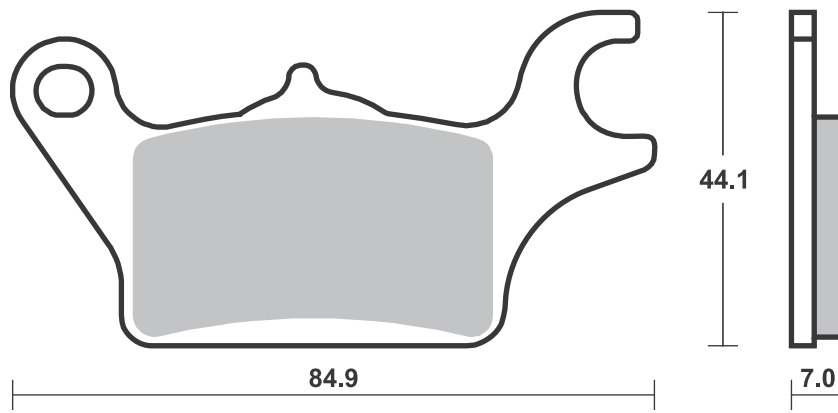



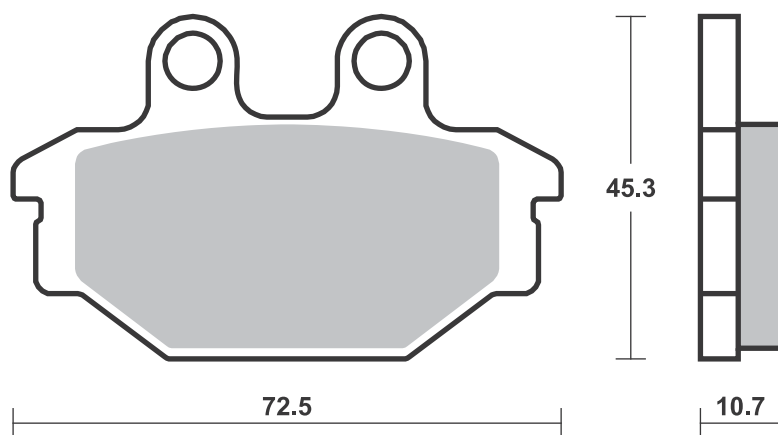
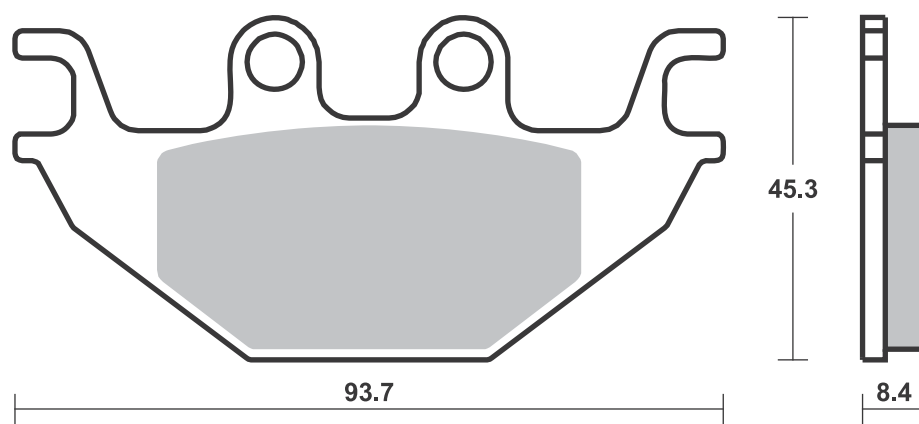





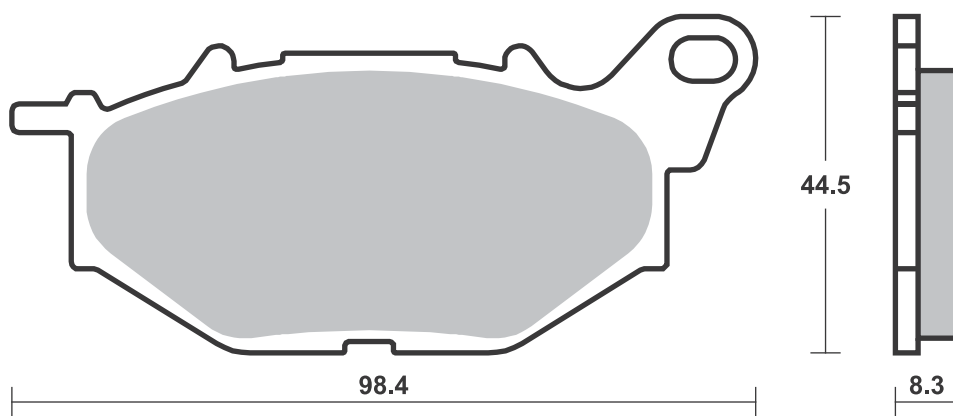
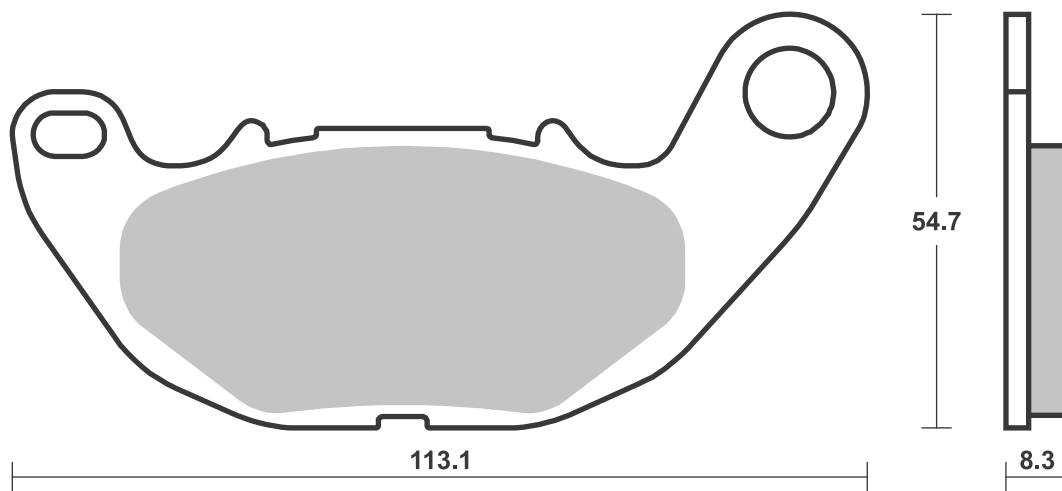



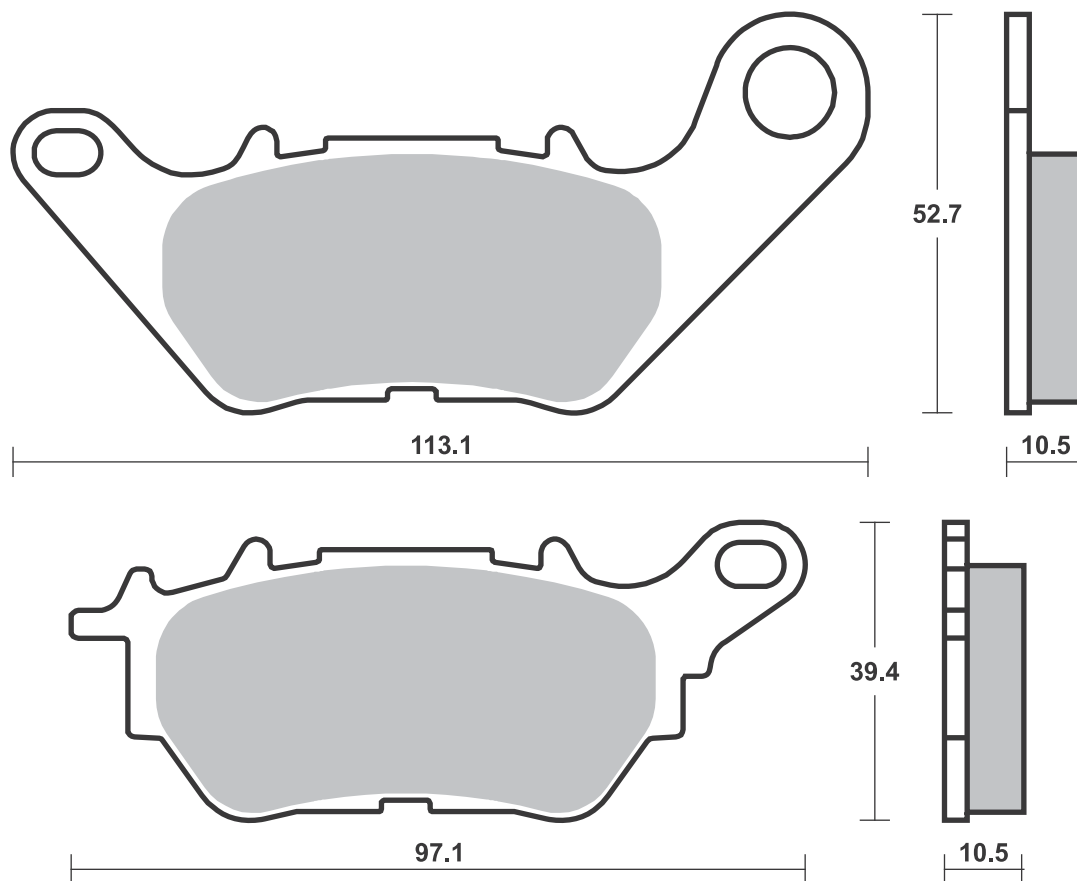



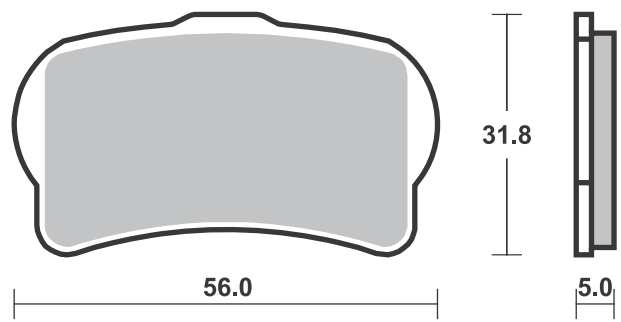
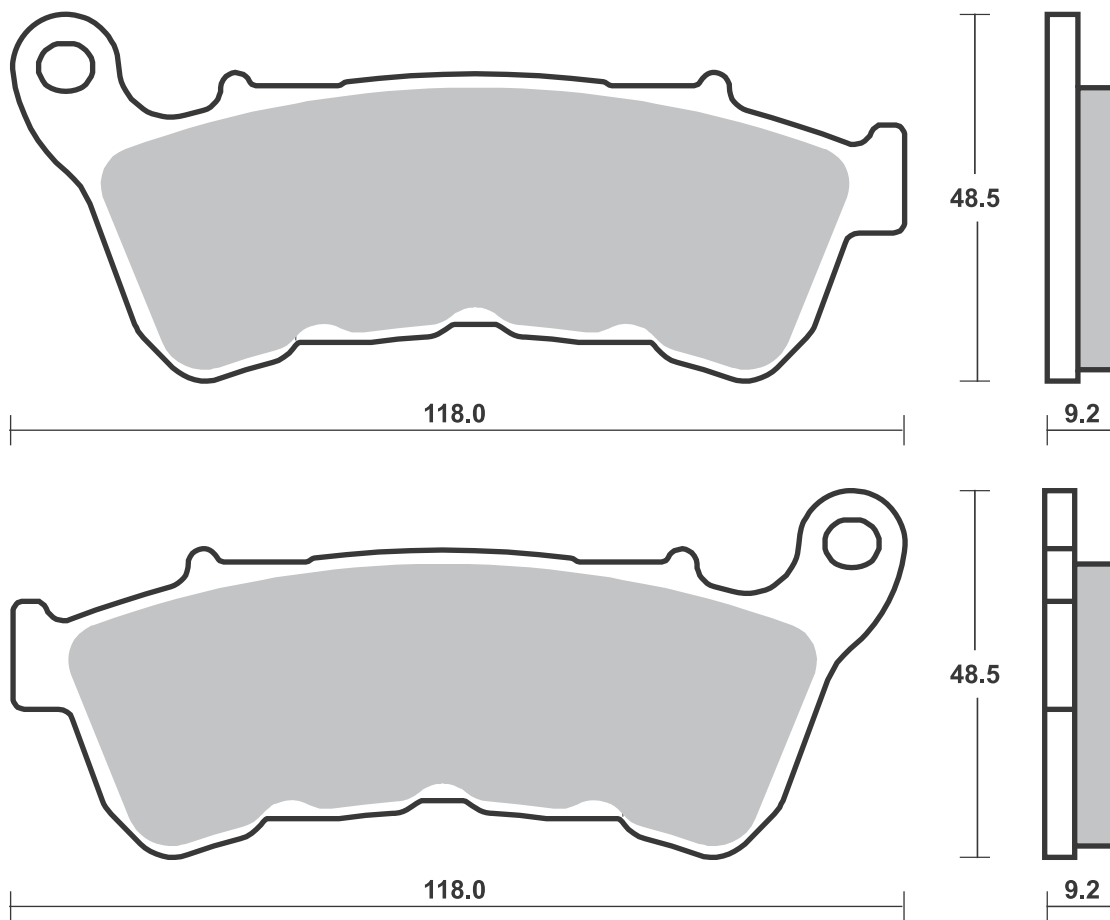



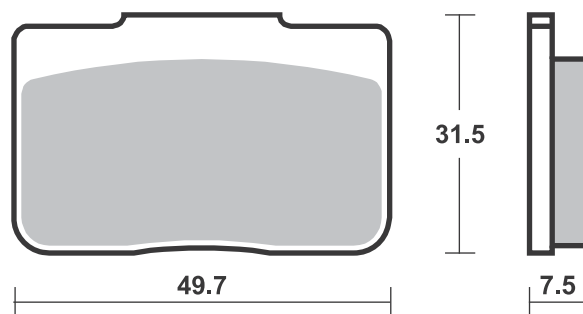
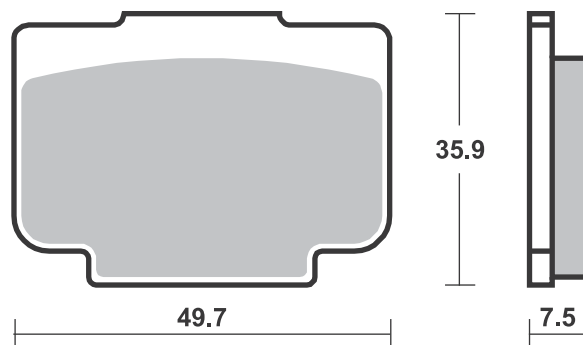
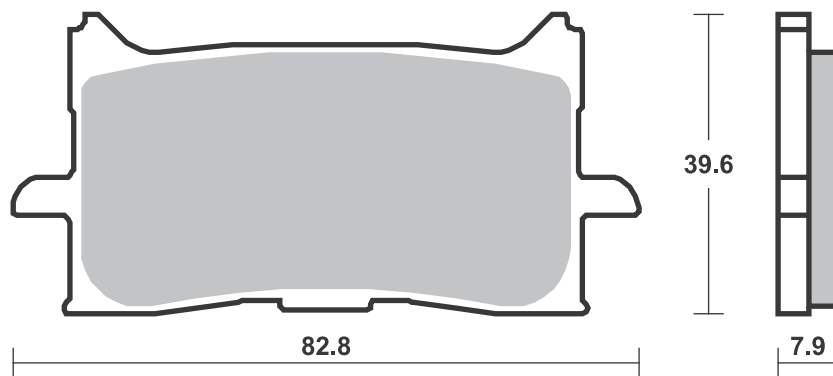





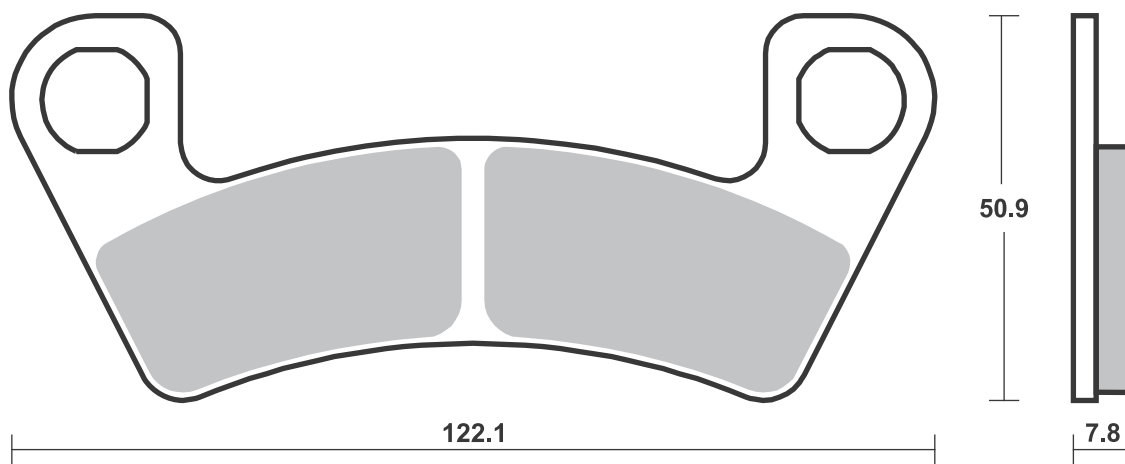
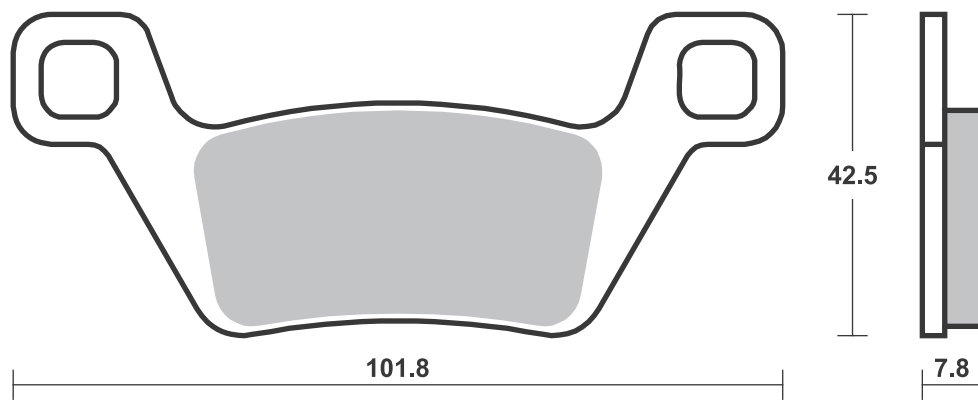



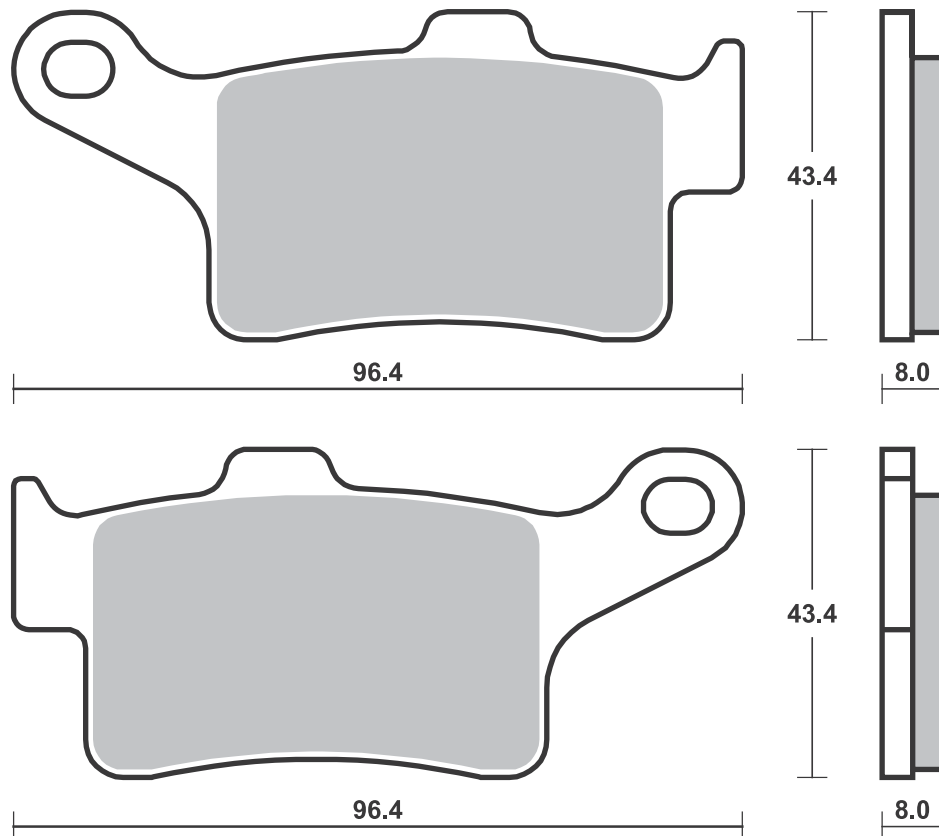
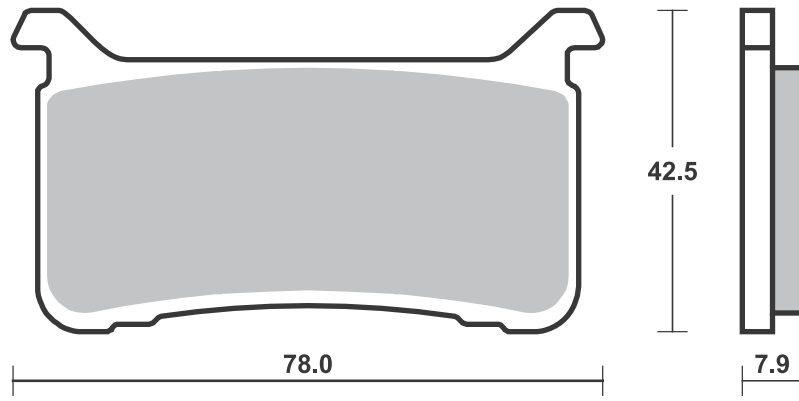



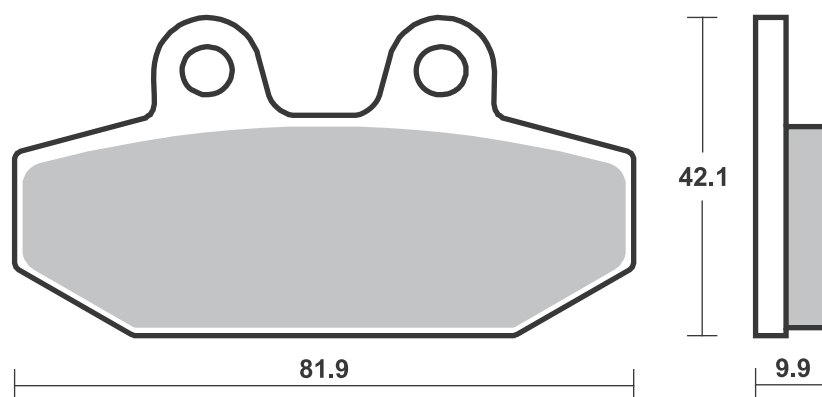



# BRAKE SHOES

## DRAWINGS, FITMENTS

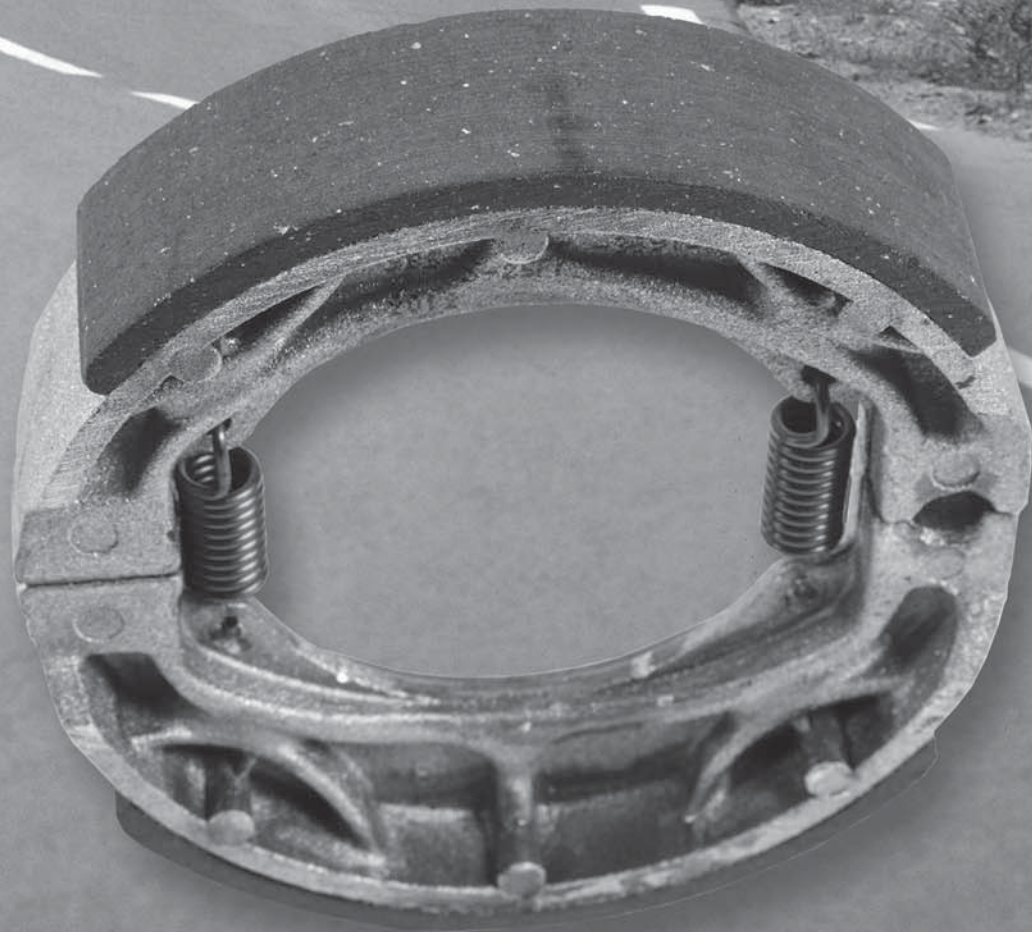





HONDA			
CRF	50 F	04-18	• •
NA	50 Express	79-81	•
NB	50 ME, Aero	83-87	•
NC	50 Express	77-80	• •
NC	50 Express	81-83	•
NN	50 MD Gyro	84	• •
NQ	50 D, Spree	84-87	• •
PA	50	78-81	•
PA	50	82-83	• •
QR	50	93-03	•
QR	50 ED, EF	82-92	•
SA	50 Elite LX, SR	88-93	•
SB	50	88-89	• •
TG	50 M Gyro S	85-86	• •
XR	50 R	00-03	• •
Z	50 R, RD	80-99	• •
CT	70	91-94	• •



SUZUKI			
DR-Z	70	08-18	• •

YAMAHA			
TT-R	50	06-18	• •

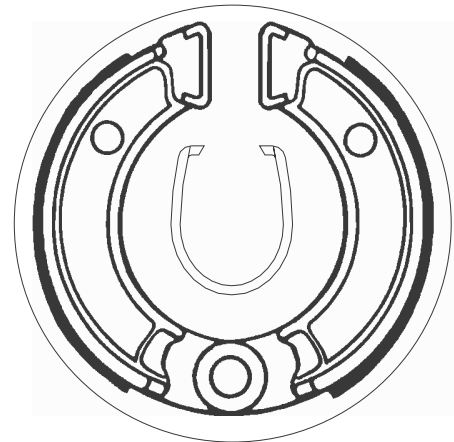

HONDA			
NA	50 Express	79-81	•
NB	50 ME, Aero	83-87	•
NC	50 Express	81-83	•
NH	50 Lead	83	•
NH	50 Lead	86-94	•
NH	50 Lead	(Drum vers.) 94	•
NH	50 Lead	SS,MR,MSE 84-85	•
NS-1	50	91-94	•
PX	50	82-83	•
QR	50 ED, EF	82-92	•
SA	50 Elite LX, SR	88-93	•
NH	80 MD Lead, Aero	83-84	•

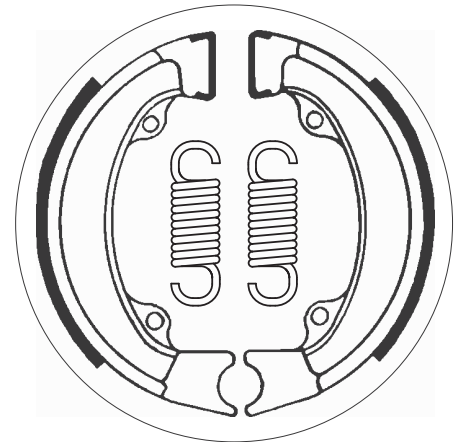

APRILIA			
SR	50 Replica	94-96	•
SR	50 Replica	(Liquid Cooled) 96	•
SR	50 WWW,	Netscaper 97-99	•

E-TON			
RXL	150 Viper	07	•

HONDA			
NH	50 Lead	83	•
NH	50 Lead	(Drum vers.) 94	•
PK	50 Walaroo	DX-STD 90-01	•
R	50 Monkey	88	•
ATC	70 K1	76-77	•



HONDA			
C	70 all models	75-83	• •
CH	80 Elite	85-88	•
NH	80 Aero	85	•
NH	80 MD Lead, Aero	83-84	•
EZ	90 Cub	90-95	• •
TRX	90	93-01	•
ANF	125 i Innova	07-11	•
ANF	125 Innova	03-06	•
ATC	125 ME, MF, MG,	MH 84-87	•
CB	125 S	84-85	•
CH	125 D, E, Spacy,	Elite 83-84	• •
NH	125 Lead Scooter	86-87	•
TRX	125	85-88	•
XL	125 K3	79	•
CH	150 D Elite	85-87	• •





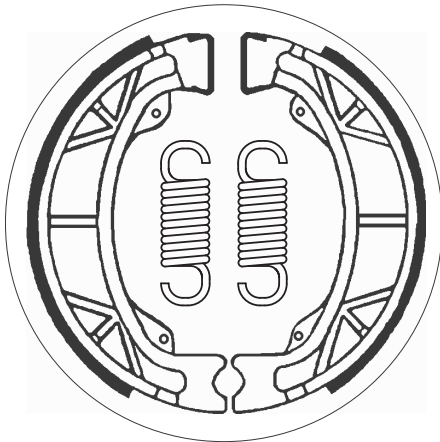

**HONDA**

ATC	185 A, S, SB	80-83	•
ATC	200	81-83	•
ATC	200 E Big Red	82-83	•
ATC	200 ES Big Red	84	•
ATC	200 M	84-85	•
ATC	200 S	84-86	•

**KYMCO**

	50 Agility	05-08	•
	50 Agility (4T) R10	06-14	•
	50 Agility (4T) R12	06-15	•
	50 Agility Basic	07	• •
	50 MXU	05-10	•
	125 Agility	06-11	•
	150 MXU	05-17	•

**MALAGUTI**

	50 Centro	93-96	•
	50 Yesterday	97-02	•
F-10	50	92-93	•
F-10	50 Jet-Line	94-98	•
F-12	50 Phantom	94-98	•
F-12	50 Phantom A.C.	99-03	•
F-15	50 Fire Fox	96-99	•
F-15	50 Fire Fox L.C.	96-08	•
SL	50 Centro	96	•

**PEUGEOT**

	e-Vivacity	11-15	•
	50 Elyseo		
	(A.J.P. cal.)	99-01	•
	50 Looxor	02-05	•
	50 Speedake		
	(A.J.P. cal)	94-01	•
	50 Speedake		
	(Brembo cal.)	94-01	•
	50 Speedake		
	(Hengtong cal.)	94-01	•
	50 Speedfight 3		
	(AC)	10-16	•
	50 Speedfight LC,		
	(A.J.P. cal.)	96-15	•
	50 Speedfight LC		
	(Brembo cal.)	96-15	•
	50 Speedfight LC		
	(Hengtong cal.)	96-15	•
	50 Trekker Road	99-00	•
	100 Elyseo		
	(A.J.P. cal.)	99-01	•

**SYM**

	50 Fiddle	09-14	•
	50 Jet, Alpha	95-97	•
	50 Jungle	96-02	•
	50 Mask	00-05	•
	50 Mask LC	00-05	•
	50 Red Devil	97-09	•
	50 Super Fancy	95-97	•
RS	50	05-09	•
	100 Super Fancy	95-00	•
	125 Attila	95-02	•
	150 Super Duke	96-01	•

**YAMAHA**

	50 Axis Pro Foot	92-99	•
--	------------------	-------	---



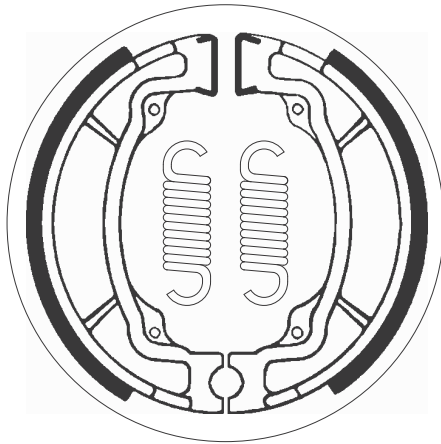

<b>HYOSUNG</b>			
	110 Midas Plus	98-04	•
FX	110 110	02-04	•
KR	110 Master	04-05	•

<b>KAWASAKI</b>			
AE	50	81-82	• •
AR	50	81-82	•
KD	80	80-87	• •
KD	80	88-90	•
KE	100	79-97	• •
KH	100	76-77	• •
KM	100	78-81	• •
KLF	110 Mojave	87-88	•
KLT	110	84-86	•
KLX	110	02-18	•
KLT	160	85	•
KLT	185	86-87	•
KLT	200	81-84	•
KLT	250	82-83	•
KLT	250 Police	84	•
KLT	250 Prairie	83-85	•

<b>SUZUKI</b>			
OR	50	79	• •
RM	50	78-80	• •
RM	80	77-79	• •
RV	90	73-81	• •
TS	90	71-73	•
RM	100	76-81	•



<b>SUZUKI</b>			
	110 Smash	03-06	• •
DR-Z	110	02-06	•
FX	110 Shogun	98-02	• •
TS	125	72	•

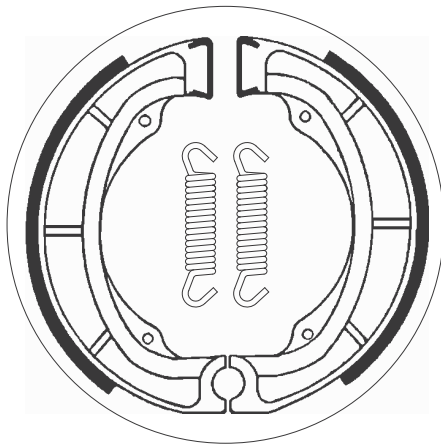

<b>KAWASAKI</b>			
KDX	250	80-82	•
KL	250	78-80	•
KX	250	75-81	•
KZ	250	80-83	•
KX	420	80-81	•

<b>SUZUKI</b>			
ALT	125	84-86	•
LT	125 E-H	84-87	•
LT	160	89-92	•
LT-F	160	91-04	•
ALT	185	85-87	•
LT	185	84-87	•
LT	230	85-86	•
LT-F	230	86-87	•
RM	250	76-78	•
RM	250	79	•
TS	250	74-82	• •
SP	370	77-79	• •
PE	400	79-81	• •
RM	400	78	•
RM	400	79	•
SP	400	80-82	• •







ø130x30

SBS 2026

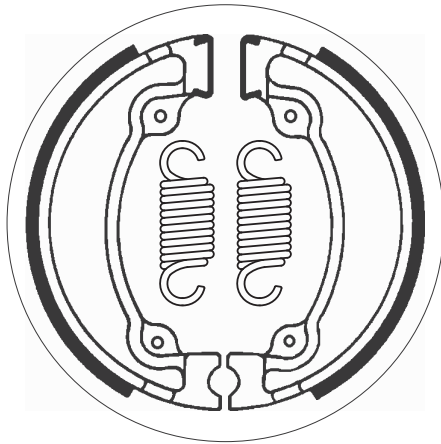

**CAGIVA**

T4	350 R	87-99	•
T4	500 E	87-90	•

**HONDA**

XL	250 S	81	•
XL	500 R	83-87	•
XL	500 RC	82	•
XL	500 SZ	80	•
XR	500 R Pro Link	81-82	•
XR	500 SZ, SA	79-80	•
XL	600 R	83-86	•
XL	600 V, Transalp	87-90	•

ø180x40

SBS 2027

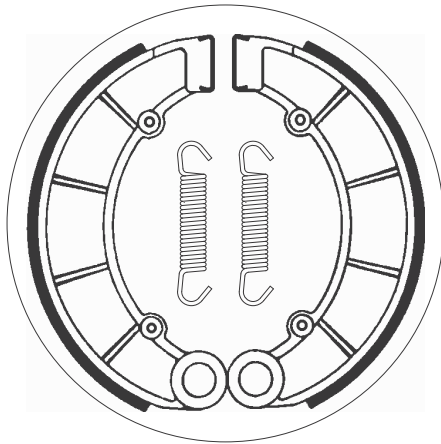

**HONDA**

CB	650	79-81	•
CB	650 C	80-85	•
CB	650 SCC		
	Nighthawk	82	•
CB	650 Z	78-81	•
CB	750 A	76-78	•
CB	750 C	80-84	•
CB	750 C, F, FII, K	85-86	•
CB	750 K Four	77-78	•
CB	750 K, L	79-80	•
CB	750 K0-K6 Four	70-76	•
CB	750 KZ	82	•
CB	750 PZ	81-84	•
CB	750 SC	82-83	•

ø110x25

SBS 2028

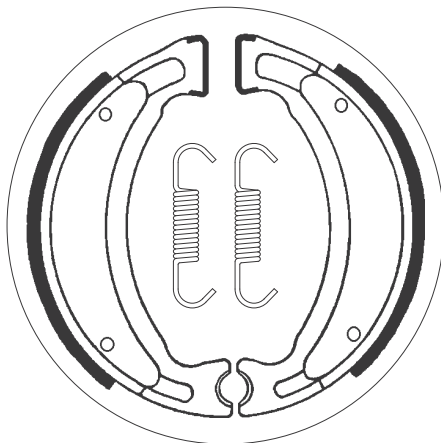

**ADLY**

25 Silver Fox	00-05	•
50 Fox	00-09	•
50 Jet	96-99	•
50 Pista,		
Pista Twin		
Light	96-99	•
50 Silver Fox	00-09	•
100 Jet	96-99	•
100 Silver Fox	06	•

**CPI**

50 Baby	02	•
50 Hussar	01-06	•
50 Mars	01-02	•
50 Oliver	03-12	•
50 Oliver City	03-12	•
50 Oliver Sport	03-12	•

**CPI**

50 Popcorn	01-02	•
------------	-------	---

**DERBI**

DXR	200 Quad		
	(Front drum)	04-05	•
DXR	250 Quad		
	(Front drum)	04-05	•

**KEEWAY**

	50 Flash	07-12	•
	50 Flash Electric	10-12	•
	50 Hurricane	06-16	•
	50 Matrix	06-15	•
F-NKD	50	10-11	•
RY8	50	07-09	•

















ø130x25

SBS 2047

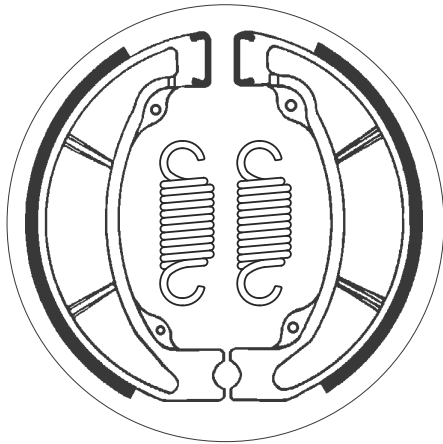

**HONDA**

CR	125 RG	86	•
CR	250 RG	86	•
CR	500 RG	86	•

ø87x20

SBS 2048

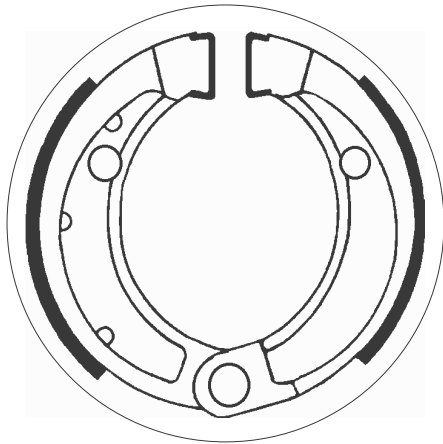

**ARCTIC CAT**

	50 2WD	04-06	•
	50 DVX	06-08	•
	90 2WD	02-04	•
	90 DVX	06-14	•

**BOMBARDIER**

	50 Quest	03-04	•
DS	50	02-06	•
	90 Quest	03-04	•
DS	90	02-06	•

**CAN-AM**

DS	50	07-11	•
DS	70	08-14	•
DS	90	07-18	•

**HONDA**

TRX	70	86-87	•
-----	----	-------	---

**POLARIS**

	50 Predator	04-14	•
	50 Scrambler	01-03	•
	90 Scrambler	01-03	•
	90 Sportsman	01-15	•

ø130x22

SBS 2049

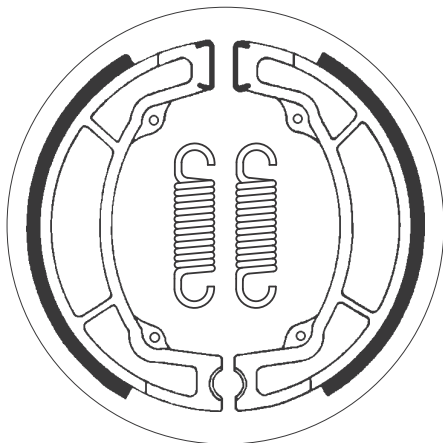

**YAMAHA**

YZ	125	83-87	•
IT	200	84-85	•
IT	200	86	•
TY	250	84-90	•
BW	350	87-88	•
TY	350	86	•





ø165x32

SBS 2053

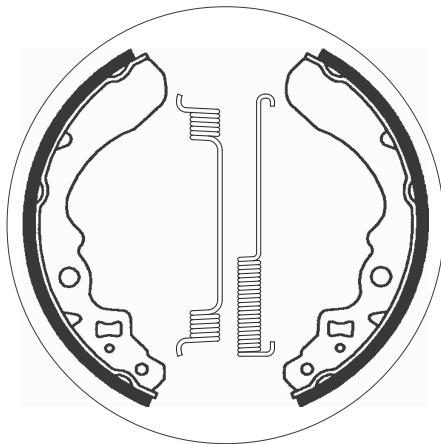

**KAWASAKI**

KAF	300 Mule 500	92-95	•
KAF	300 Mule 550	03-05	•

**SUZUKI**

LT	250 4WD	87-98	•
LT-F	250	88-01	•
LT-F	250 4WD V, W Quadrunner	97-98	•

ø160x30

SBS 2054

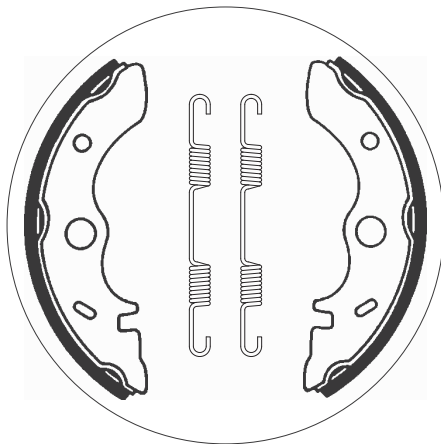

**KAWASAKI**

KLF	300 A1, A2 Bayou	86-87	•
-----	------------------	-------	---

ø140x30

SBS 2055

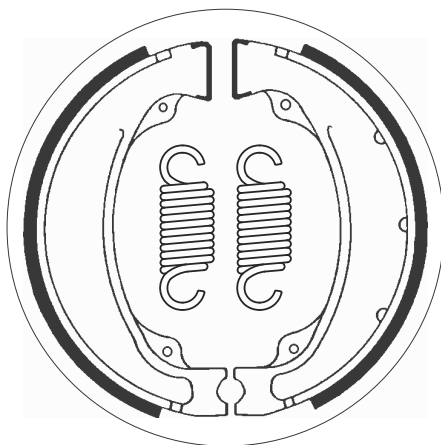

**HONDA**

TRX	250 EX Sportrax	01-08	•
TRX	250 Recon	97-14	•
TRX	250 X	08-13	•

















ø180x30

SBS 2088

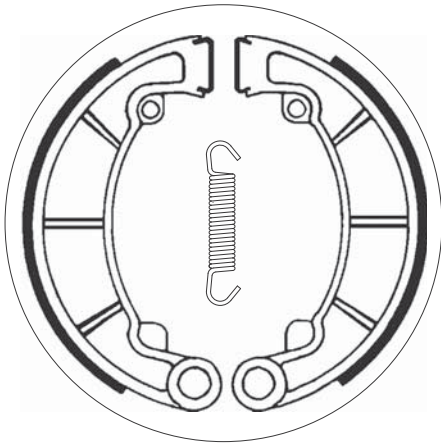

**KAWASAKI**

KH	250	76-80	•
S2A	350	73	•
KH	400	76-78	•
KZ	400	74-77	•

ø200x35

SBS 2091

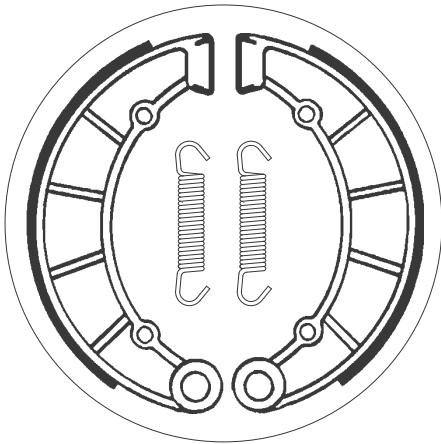

**KAWASAKI**

KZ	750 H	72-75	•
KZ	900	76-77	•
KZ	900 A	76-77	•

ø95x20

SBS 2092

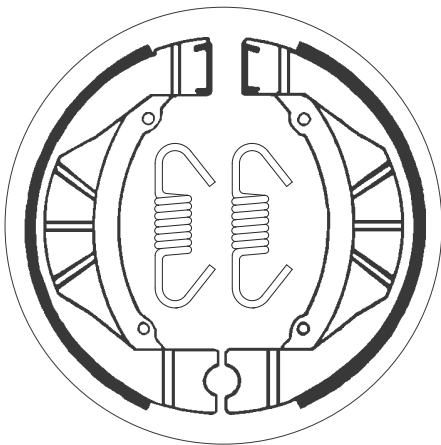

**KAWASAKI**

KX	80	83	•
----	----	----	---

**SBS 2093**

ø90x20



**KAWASAKI**

KX	60	83-03	•	•
KX	80	83-87	•	•
KLX	110	02-18	•	

**SUZUKI**

RM	60	03	•	•
DR-Z	110	02-06	•	

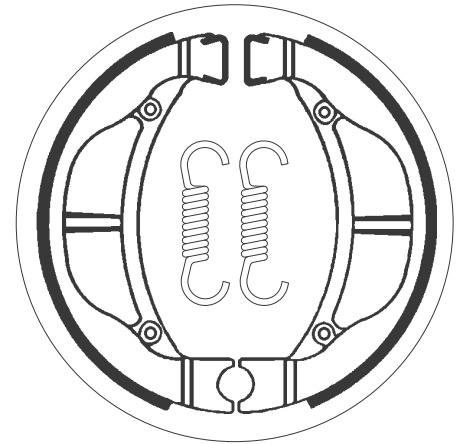

**SBS 2097**

ø180x28



**SUZUKI**

GT	250	73-78	•	
GT	380	73-77	•	
GT	380 Asco	77	•	
GS	400	77-82	•	

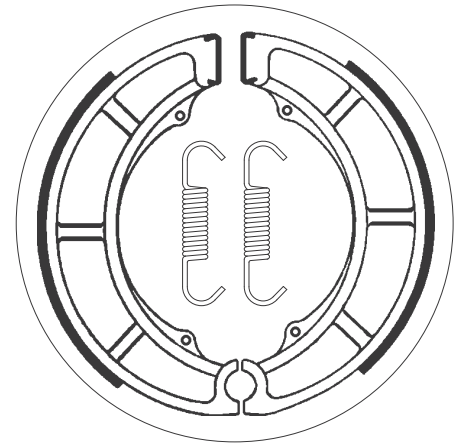

**SBS 2098**

ø180x40



**SUZUKI**

RE	5M, A	75-77	•	
LT	250	85-86	•	
LT-F	250 4WD V, W Quadrunner	97-98	•	
LT	300	87-89	•	
GT	500	73-77	•	
GT	550	73-77	•	
GT	750	73-77	•	

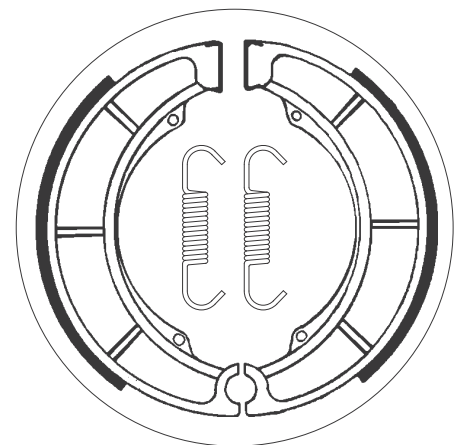



















ø120x25

SBS 2181

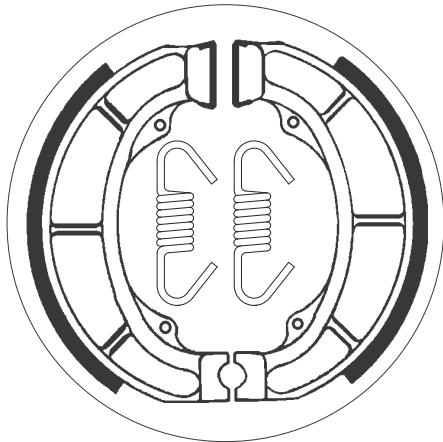

**DERBI**

50 Atlantis	99-08	•
50 Easy	96-98	•
50 Hunter	97-99	•
50 Manhattan	99	•
50 Vamos FL	95-99	•
50 Vamos L	95	•
ST 50 Paddock	96-99	•

**SUZUKI**

AH 50 Adress	92-95	•
ZZ 50 Scooter	92	•
AH 80 Adress, V, Tune	88-91	•
AH 80 Scooter	92-94	•
AH 100 V Adress	91-94	•
LT 160	89-92	•
LT-F 160	91-04	•

ø95x20

SBS 2182

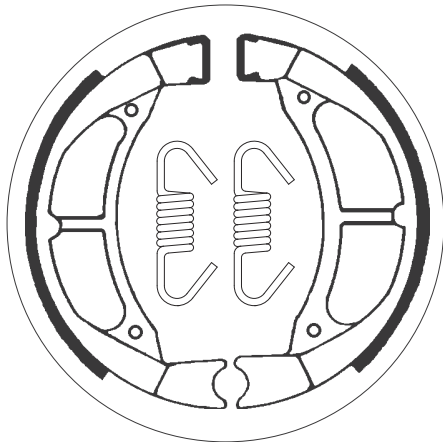

**SUZUKI**

RM 80	82-89	•
-------	-------	---

**YAMAHA**

YZ 50	80-83	•	•
YZ 60	85	•	•
BW 80	86-90	•	•
YZ 80	74-79	•	•
YZ 80	80-85	•	•
YZ 80	86-92	•	•
TT-R 90	00-10	•	•
TT-R 110	08-18	•	•

ø130x28

SBS 2183

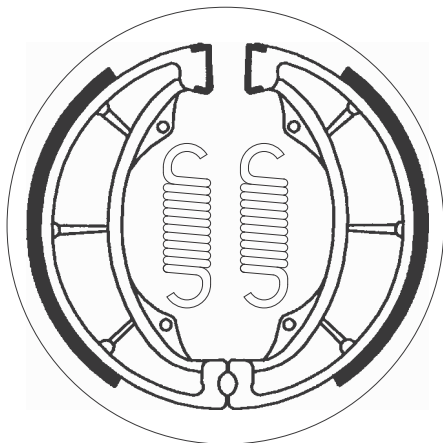

**KAWASAKI**

KLF 110 Mojave	87-88	•
KLT 110	84-86	•
KE 125	76-85	•
KX 125	74-82	•
KLT 160	85	•
KDX 175	80-82	•
KE 175	76-78	•
KLT 185	86-87	•
KDX 250	83-84	•
KLX 250	79-80	•
KT 250 all models	75-80	•
KX 250	82-85	•
KX 500	83-85	•
KL 600	84-86	•
KLR 600	84-86	•
KLR 600 E	85-94	•

**SBS 2188**

ø110x23



**SYM**

125 Husky	96-98	•
125 Super Duke	95-01	•
150 Husky	99-02	•

**TGB**

50 202T	99-02	•
---------	-------	---

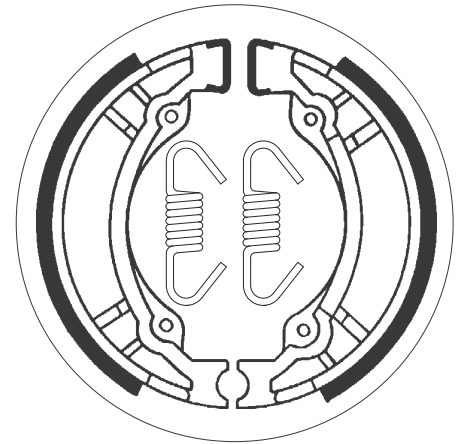

**SBS 2189**

ø130x25



**HONDA**

CN 250 Helix	86-87	•
--------------	-------	---

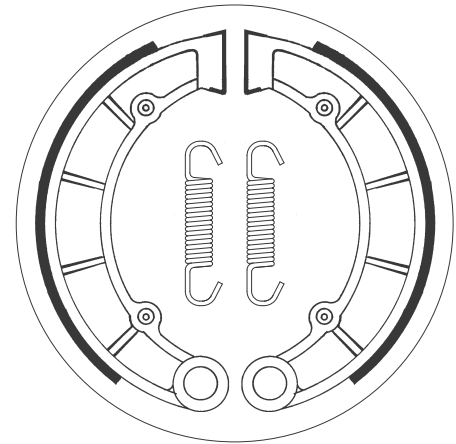

**SBS 2197**

ø180x35



**KAWASAKI**

KLF 300 Bayou		
Left/Rear	89-05	•
KLF 400 Bayou Left	93-99	•
KVF 400 Prairie	97-98	•

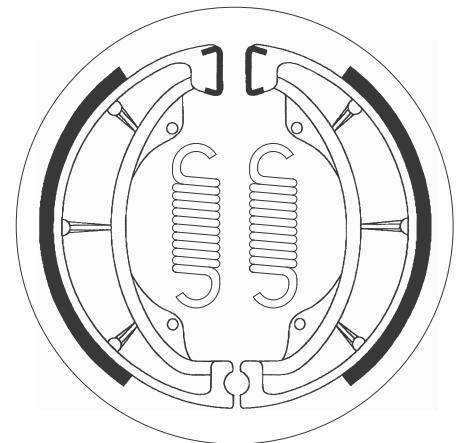



**SBS 2205**

ø140x25



<b>APRILIA</b>			
SR	125	99-03	•
SR	150	00-03	•
<b>DERBI</b>			
	125 Boulevard	03-07	•
	150 Boulevard	03-09	•
<b>PIAGGIO VESPA</b>			
	100 Fly	07-15	•
	100 Zip	07-10	•
	150 Fly	06-07	•

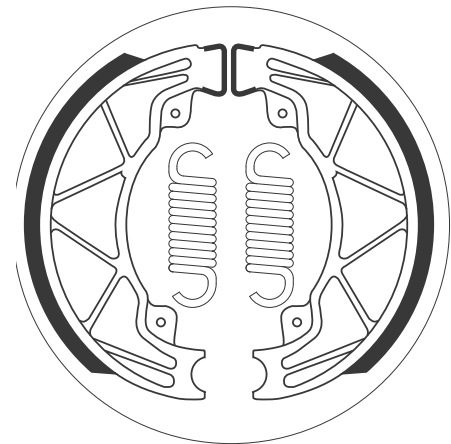

**SBS 2206**

ø105x25



<b>DERBI</b>			
	50 Aventura	96	•
	50 Vamos R		
	(A.J.P. cal.)	95	•
	50 Vamos R		
	(Brembo cal.)	95	•
	50 Variant		
	Sport-R	01-13	•

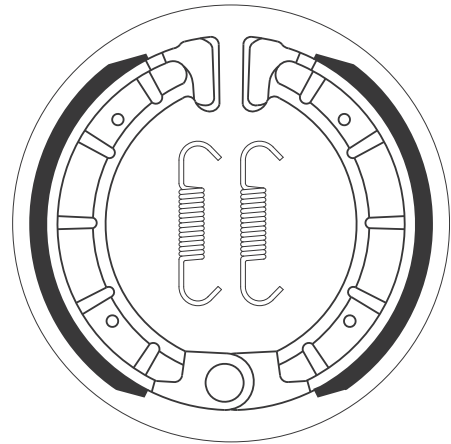

**SBS 2207**

ø160x30



<b>HONDA</b>			
TRX	350 Rancher /		
	ES 2x4, 4x4	00-09	•
TRX	400 AT	04-11	•
TRX	400 FW Fourtrax		
	Foreman	95-02	•
TRX	450 Foreman ES,		
	Foreman S	98-04	•

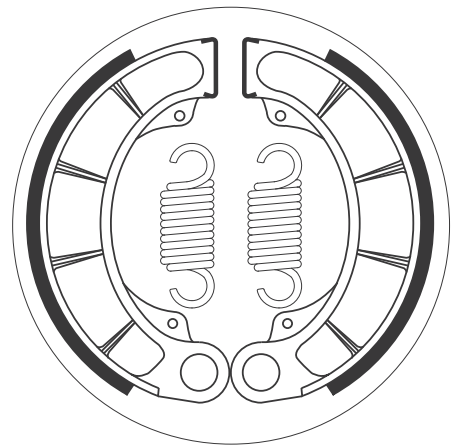

Dimensions in mm / Dimensions en mm  
1" = 25.4 mm , 1 mm = 0.04"







# CROSSLIST

**BRAKE PADS**

**SAME SHAPE / DIFFERENT THICKNESS**

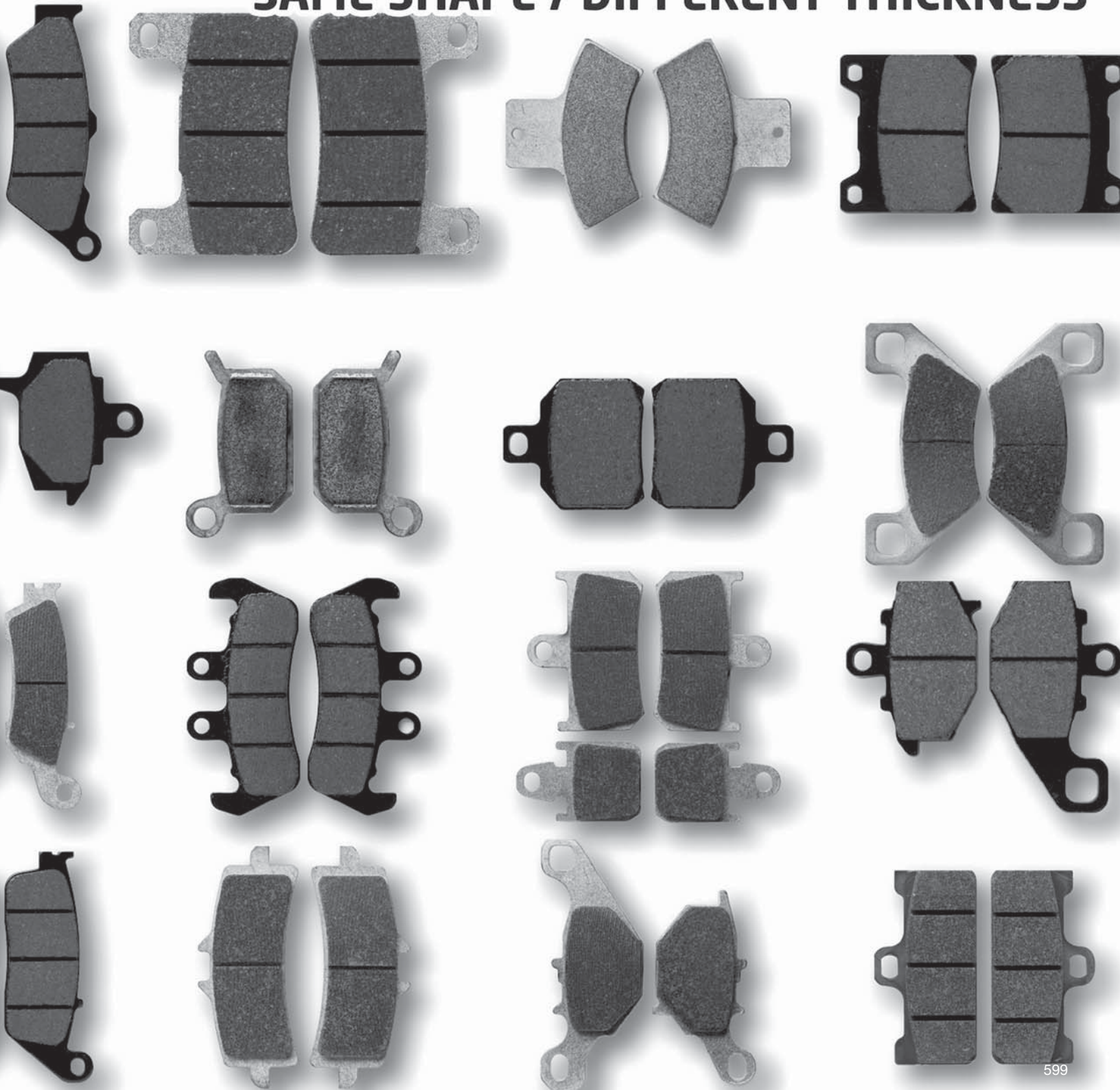

SBS Ref.	Total th.	SBS Ref.	Total th.	SBS Ref.	Total th.	SBS Ref.	Total th.	SBS Ref.	Total th.
103	7.0	200	7.5						
104	7.3	125	9.3						
115	8.0	209	5.3						
119	9.2	134	8.0						
121	9.0	144	9.5						
123	6.3	143	7.0						
125	9.3	104	7.3						
127	9.0	160	11.0						
134	8.0	119	9.2						
142	6.9	202	6.2						
143	7.0	123	6.3						
144	9.5	121	9.0						
160	11.0	127	9.0						
163	9.2	197	8.0						
181	10.4	183	8.1	184	8.9				
183	8.1	184	8.9	181	10.4				
184	8.9	181	10.4	183	8.1				
197	8.0	163	9.2						
200	7.5	103	7.0						
202	6.2	142	6.9						
209	5.3	115	8.0						
216	7.0	222	9.0						
222	9.0	216	7.0						
508	12.0	517	9.5						
517	9.5	508	12.0						
523	10.4	698	7.0						
526	11.0	556	9.0						
539	8.0	540	9.5						
540	9.5	539	8.0						
542	11.0	572	9.0						
551	7.0	814	7.5						
552	8.0	571	9.5						
556	9.0	526	11.0						
558	7.3	709	9.3						
571	9.5	552	8.0						
572	9.0	542	11.0						
581	7.1	582	9.5						
582	9.5	581	7.1						
584	6.5	592	7.5						
590	10.5	613	8.8						
592	7.5	584	6.5						
599	8.0	661	9.0						
600	8.4	647	10.5						
611	8.0	713	9.2						
613	8.8	590	10.5						
614	10.7	881	9.0						
624	8.5	714	7.0						
627	8.1	700	9.6	654	10.4	630	9.6		
630	9.6	627	8.1	700	9.6	654	10.4		
632	8.7	648	9.5						
638	8.0	688	9.2						
647	10.5	600	8.4						
648	9.5	632	8.7						
654	10.4	630	9.6	627	8.1	700	9.6		
661	9.0	599	8.0						
662	11.0	678	8.0						
671	7.6	742	8.6/10.1	924	9.0				
676	8.2	729	10.0	779	12.0				
678	8.0	662	11.0						
688	9.2	638	8.0						
695	8.3	711	10.2						
698	7.0	523	10.4						
700	9.6	654	10.4	630	9.6	627	8.1		
704	8.3	886	10.9	920	9.8				
709	9.3	558	7.3						
711	10.2	695	8.3						
713	9.2	611	8.0						
714	7.0	624	8.5						







# CROSSLIST

SBS -

EBC / Braking / DP / Vesrah / Ferodo / Galfer / Harley Davidson OE

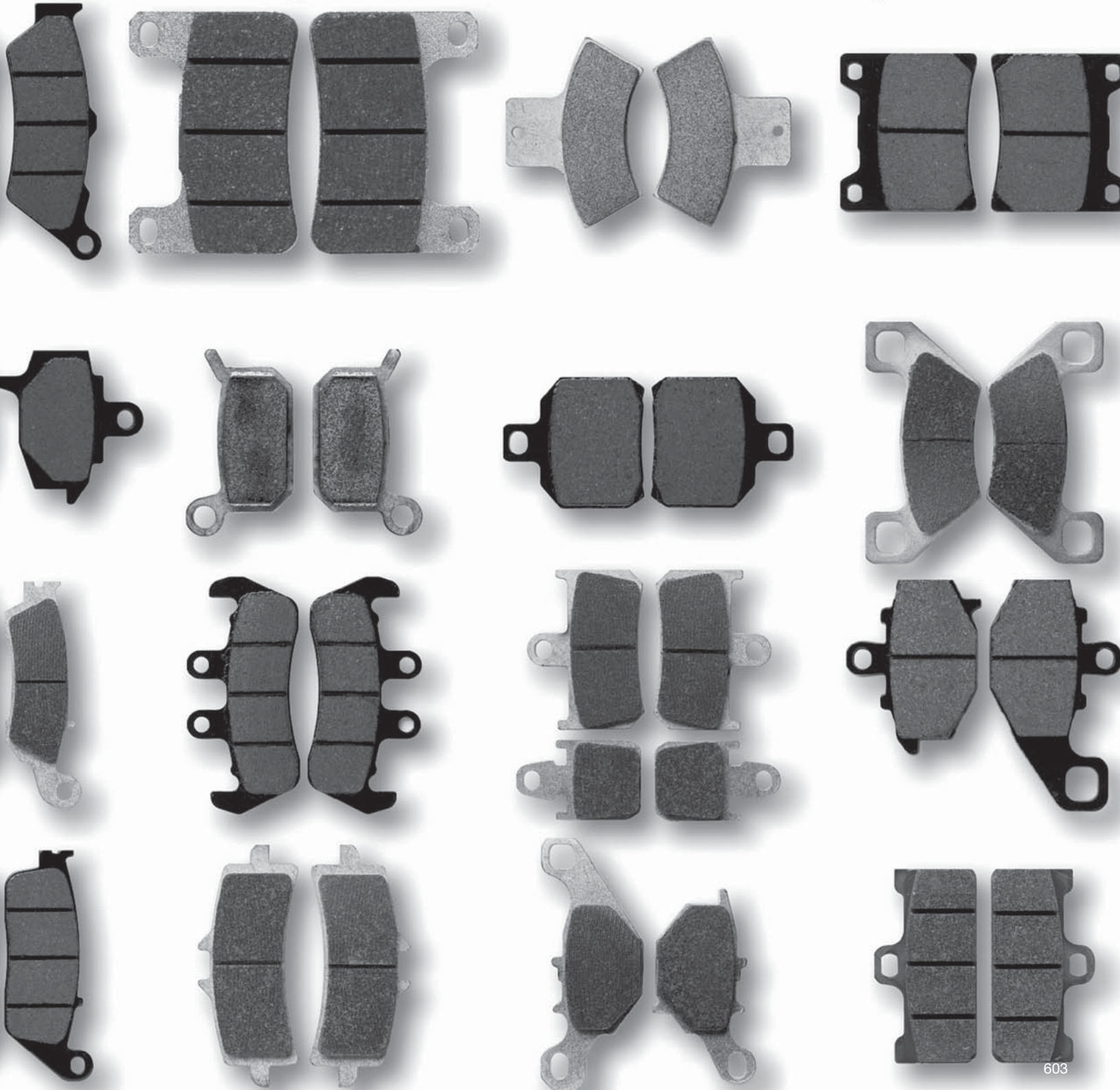

EBC No.	SBS No.	EBC No.	SBS No.	EBC No.	SBS No.	EBC No.	SBS No.
FA11	504	FA86	103	FA162	659	FA226	184
FA12	502	FA86	200	FA163	641	FA226	627
FA13	501	FA86	551	FA164	636	FA228	163
FA16	523	FA86	814	FA165	134	FA228	713
FA18	506	FA88	555	FA165	638	FA229	705
FA20	617	FA90	561	FA165/2	633	FA230	122
FA21	576	FA92	104	FA167	148	FA230	702
FA22	520	FA92	558	FA167	652	FA231	704
FA24/2	513	FA93	203	FA167	817	FA231/2	886
FA26	679	FA93	585	FA169	111	FA232	717
FA27	505	FA94	579	FA169	619	FA234	129
FA29	508	FA95	566	FA170	644	FA235	141
FA31	517	FA99	132	FA171	640	FA236	624
FA32	509	FA99	595	FA172	137	FA244	706
FA33	510	FA101	107	FA173	684	FA249	729
FA34	507	FA101	575	FA174	657	FA249	676
FA35	511	FA103	577	FA175	656	FA249/2	779
FA36	512	FA104	570	FA176	112	FA251	692
FA37	514	FA105	580	FA177	681	FA252	198
FA38	515	FA106	581	FA179	170	FA252	634
FA39	516	FA106/2	582	FA179	663	FA254	715
FA40	525	FA107A	599	FA181	151	FA256	108
FA41	528	FA111	610	FA181	671	FA256	588
FA45	526	FA115	105	FA182	665	FA257	115
FA47	138	FA115	559	FA183	677	FA257/2	209
FA47	519	FA116	109	FA184	655	FA257/2	879
FA48	522	FA116	607	FA185	694	FA258	726
FA50	532	FA118	596	FA186	117	FA260	142
FA51	533	FA119	589	FA187	622	FA261	736
FA52	529	FA120	594	FA188	686	FA261/2	880
FA54	100	FA121	593	FA189	685	FA263	707
FA54	536	FA122	598	FA190	683	FA264	140
FA55	503	FA123	590	FA191	682	FA264	708
FA56	524	FA124	600	FA192	687	FA266	157
FA57	527	FA124/2	647	FA193	123	FA266	730
FA60	574	FA125	603	FA193	143	FA267	733
FA61	545	FA126	601	FA194	168	FA268	145
FA62	530	FA128	591	FA194	774	FA270	755
FA63	556	FA129	597	FA196	181	FA271	758
FA65	534	FA130	602	FA196	654	FA272	719
FA67	135	FA131	144	FA196	700	FA273	756
FA67	546	FA131	604	FA197	119	FA275	155
FA67	586	FA131/3	121	FA197	688	FA275	728
FA67/2	541	FA132	621	FA198	699	FA281	722
FA68	539	FA134	608	FA199	128	FA283	146
FA68	540	FA135	197	FA199	691	FA283	740
FA69/2	127	FA135	611	FA200	669	FA291	815
FA69/2	572	FA136	616	FA201	668	FA296	734
FA69/3	160	FA137	649	FA204	625	FA297	150
FA69/3	542	FA140	614	FA206	114	FA298	152
FA70	547	FA141	615	FA206	667	FA298	747
FA71	537	FA142	183	FA208	175	FA301	153
FA72	543	FA142	184	FA208	675	FA302	752
FA74	606	FA142	627	FA209	176	FA303	802
FA76	560	FA143	623	FA209	674	FA304	746
FA77	554	FA145	624	FA209/2	176	FA305	154
FA78	549	FA146	620	FA209/2	674	FA305	749
FA79	553	FA147	626	FA210	658	FA306	178
FA80	552	FA151	110	FA214	197	FA306	792
FA80/2	571	FA151	618	FA214	611	FA307	196
FA81	550	FA152	632	FA215	134	FA307	754
FA83	101	FA152/2	648	FA215	638	FA313	757
FA83	544	FA155	637	FA216	678	FA314	787
FA83/2	102	FA156	672	FA216/2	662	FA315	785
FA83/2	548	FA157	635	FA217	660	FA317	767
FA84	592	FA158	631	FA218	695	FA319	169
FA84/2	562	FA159	642	FA218/2	711	FA319/2	769
FA84/3	584	FA160	645	FA222	701	FA320	763
FA85	557	FA161	556	FA226	183	FA321	166

<b>EBC No.</b>	<b>SBS No.</b>	<b>EBC No.</b>	<b>SBS No.</b>	<b>EBC No.</b>	<b>SBS No.</b>	<b>EBC No.</b>	<b>SBS No.</b>
FA321	772	FA413	835	FA629	915		
FA322	762	FA414	836	FA630	900		
FA323	125	FA415	193	FA636	892		
FA323	709	FA417	838	FA638	922		
FA323/2	104	FA418	187	FA640	934		
FA323/2	558	FA419	833	FA641/4	923		
FA324	159	FA424	676	FA643	924		
FA325	794	FA425	191	FA644	939		
FA335	796	FA427	201	FA650	716		
FA336	165	FA427	847	FA652	223		
FA337	574	FA428	816	FA655	222		
FA342	801	FA430	194	FA662	230		
FA343	225	FA431	848	FA662	932		
FA343	784	FA432	214	FA663	229		
FA344	799	FA432	844	FA663	931		
FA345	795	FA433/4	843	FA672	929		
FA346	777	FA434	846	FA673	889		
FA347	782	FA435/4	805	FA678	221		
FA348	770	FA435/4	887	FA679	940		
FA349	798	FA436	834	FA681	224		
FA350	167	FA442/4	839	FA691	925		
FA350	773	FA443	850	FA693	228		
FA351	803	FA444	849	FA693	859		
FA353	177	FA445	852	FA694	226		
FA354	800	FA446	851				
FA355	171	FA447	841				
FA355	775	FA450	840				
FA357	783	FA452	897				
FA358	158	FA453	914				
FA363	742	FA454/4	856				
FA366	789	FA456	898				
FA367	790	FA457	853				
FA368	791	FA458	854				
FA369	788	FA460	857				
FA373	813	FA462	866				
FA374	173	FA463	867				
FA374	780	FA464	227				
FA375	180	FA464	858				
FA375	797	FA465	228				
FA377	810	FA465	859				
FA379	806	FA468	907				
FA380	198	FA475	899				
FA380	634	FA484	210				
FA381	807	FA484	878				
FA382	113	FA488	862				
FA382	651	FA489	906				
FA384	206	FA490	905				
FA387	808	FA491	864				
FA388	192	FA491	870				
FA388	828	FA492	208				
FA389	694	FA495	895				
FA390	809	FA496	881				
FA393	190	FA498	204				
FA395	822	FA499/4	869				
FA396	122	FA600	945				
FA396	702	FA602	872				
FA398	908	FA603	205				
FA399	189	FA605	904				
FA399	821	FA606	877				
FA400	826	FA607	195				
FA401	820	FA608	212				
FA403	896	FA610	912				
FA405	842	FA611	845				
FA407	703	FA612	885				
FA408	185	FA613	778				
FA409	830	FA617	911				
FA410	829	FA618	910				
FA411	174	FA627	215				
FA412	182	FA627	893				

Braking No.	SBS No.	Braking No.	SBS No.	Braking No.	SBS No.	Braking No.	SBS No.
600	647	696	611	779	667	910	828
601	508	696	197	780	674	910	192
602	510	697	608	782	705	911	813
603	511	698	597	784	706	912	591
604	514	699	602	785	702	913	637
605	515	700	603	786	634	914	649
606	516	701	604	786	198	915	717
607	520	702	544	787	704	916	754
608	524	703	536	794	742	917	757
609	527	704	593	795	713	918	758
610	528	705	589	796	708	919	767
611	530	706	594	797	701	920	787
612	519	707	624	801	676	921	799
613	506	709	626	801	729	922	801
614	532	710	636	806	703	923	810
616	517	711	614	812	726	924	833
617	507	712	615	813	735	925	834
619	513	715	631	813	736	927	838
620	539	716	627	813	156	928	839
621	559	716	183	815	736	929	840
622	512	717	620	815	722	930	841
623	541	718	623	817	581	931	842
624	545	719	556	822	728	932	843
625	548	720	630	822	155	933	844
627	560	720	700	826	733	934	830
628	561	721	618	827	734	935	835
629	571	722	632	828	730	936	836
630	572	725	638	830	740	937	805
633	537	725	134	830	146	938	857
635	613	726	601	831	802	939	856
637	633	727	641	832	803	940	709
638	651	728	635	839	729	941	864
639	729	729	645	840	747	942	862
642	714	732	579	843	826	943	853
643	715	733	668	857	716	944	854
644	554	734	669	859	746	945	204
645	526	735	616	860	755	946	858
646	533	736	621	867	784	947	870
647	534	738	598	868	169	948	195
648	574	739	644	869	749	949	872
650	721	740	681	870	762	950	869
651	547	741	652	871	772	951	846
652	540	742	657	873	783	952	877
653	722	743	684	875	765	954	205
654	542	744	619	878	773	955	885
656	552	745	640	879	778	956	881
658	550	746	671	883	775	957	892
661	555	748	654	885	780	959	894
662	557	748	181	886	777	960	900
664	543	750	663	889	789	961	208
666	553	750	170	890	790	962	880
667	558	751	665	891	791	963	792
667	104	756	622	892	796	964	821
668	549	759	672	893	788	965	915
669	546	762	682	894	752	968	931
671	595	763	685	895	795	969	932
673	551	764	686	896	182	970	924
679	570	765	683	897	794	971	940
680	577	768	656	898	806	973	934
681	582	769	655	899	809	974	715
683	596	770	120	900	807	977	925
684	588	771	659	901	808		
685	575	772	694	902	797		
686	592	773	675	903	769		
687	580	775	687	904	185		
688	566	776	695	905	820		
690	600	776	711	906	782		
692	590	777	691	907	763		
694	607	777	128	908	193		



DP No.	SBS No.	DP No.	SBS No.	DP No.	SBS No.	DP No.	SBS No.
DP001	111	DP211	197	DP411	197	DP628	742
DP001	619	DP211	611	DP411	611	DP629	707
DP002	117	DP211	713	DP412	134	DP630	706
DP008	120	DP212	620	DP412	633	DP631	157
DP009	140	DP213	624	DP412	638	DP631	730
DP009	708	DP213	714	DP413	137	DP633	123
DP012	595	DP214	626	DP414	170	DP634	114
DP013	145	DP215	635	DP414	663	DP634	667
DP014	180	DP216	686	DP415	665	DP635	142
DP014	797	DP217	701	DP416	683	DP638	762
DP015	152	DP218	122	DP417	616	DP639	778
DP015	747	DP218	702	DP418	198	DP640	815
DP101	517	DP219	146	DP418	634	DP641	796
DP102	508	DP219	740	DP419	733	DP701	506
DP103	526	DP220	765	DP420	155	DP811	562
DP104	127	DP300	510	DP420	728	DP811	592
DP104	572	DP302	510	DP421	128	DP812	104
DP105	160	DP303	530	DP421	691	DP812	558
DP105	542	DP304	512	DP423	769	DP813	610
DP106	552	DP305	510	DP424	169	DP814	603
DP106	571	DP307	556	DP500	523	DP815	604
DP107	100	DP308	539	DP502	899	DP815	144
DP107	536	DP308	540	DP504	869	DP816	584
DP108	108	DP308/9	539	DP508	872	DP817	649
DP108	588	DP308/9	540	DP509	870	DP821	591
DP109	600	DP309	539	DP510	904	DP841	576
DP110	593	DP309	540	DP514	885	DP843	637
DP111	103	DP310	113	DP519	877	DP844	756
DP111	551	DP310	135	DP524	915	DP900	579
DP111	561	DP310	546	DP528	900	DP901	549
DP112	622	DP310	586	DP535	700	DP902	642
DP113	623	DP310	651	DP537	715	DP902	716
DP114	104	DP310	684	DP538	924	DP903	643
DP114	558	DP310	692	DP552	931	DP904	668
DP115	614	DP311	557	DP557	932	DP905	669
DP115	881	DP312	102	DP600	506	DP906	513
DP116	647	DP312	101	DP601	143	DP907	537
DP117	181	DP312	544	DP601	138	DP908	543
DP117	183	DP312	548	DP601	519	DP909	717
DP117	627	DP313	602	DP601	737	DP911	662
DP117	630	DP314	597	DP602	132	DP911	678
DP117	654	DP315	632	DP602	595	DP912	658
DP118	184	DP315	648	DP604	601	DP913	662
DP118	700	DP316	615	DP605	608	DP914	758
DP119	110	DP317	631	DP606	621	DP915	755
DP119	112	DP318	556	DP607	105	DP916	509
DP119	618	DP320	677	DP607	188	DP917	560
DP121	657	DP320	687	DP607	559	DP919	767
DP122	685	DP321	694	DP608	640	DP919	816
DP124	721	DP322	705	DP609	636	DP920	196
DP125	880	DP323	704	DP610	109	DP920	754
DP126	722	DP324	676	DP610	607	DP921	777
DP126	736	DP324	729	DP611	574	DP922	782
DP127	734	DP326	726	DP613	148	DP923	783
DP127	860	DP328	752	DP613	652	DP926	795
DP128	156	DP400	504	DP614	566	DP927	125
DP128	735	DP401	507	DP615	644	DP927	174
DP129	784	DP402	547	DP617	151	DP927	709
DP200	503	DP403	550	DP617	671	DP931	770
DP202	515	DP404	555	DP618	641	DP932	787
DP203	512	DP405	580	DP620	554	DP935	791
DP204	511	DP406	107	DP621	121	DP937	746
DP205	533	DP406	575	DP622	175	DP940	790
DP206	534	DP406	596	DP622	675	DP942	788
DP207	556	DP407	570	DP623	176	DP944	191
DP208	581	DP408	589	DP623	674	DP944	813
DP209	582	DP409	590	DP625	703	DP946	789
DP210	577	DP409	613	DP626	695	DP947	806
DP211	163	DP410	645	DP626	711	DP948	807

DP No.	SBS No.	DP No.	SBS No.	DP No.	SBS No.	DP No.	SBS No.
DP949	808	SDP976	839				
DP950	809	SDP978	841				
DP952	774	SDP978	901				
DP953	820	SDP993	856				
DP956	822	SDP999	864				
DP957	826						
DP962	830						
DP963	833						
DP964	838						
DP967	810						
DP967	930						
DP971	846						
DP973	834						
DP973	862						
DP976	839						
DP978	841						
DP978	901						
DP979	850						
DP980	849						
DP981	852						
DP982	851						
DP983	840						
DP984	898						
DP986	853						
DP987	854						
DP989	866						
DP990	867						
DP993	856						
DP996	897						
DP997	898						
DP997	800						
DP999	864						
ODO009	708						
ODP001	619						
ODP004	559						
ODP005	607						
ODP011	544						
ODP012	595						
ODP014	797						
ODP015	747						
RDP324	676						
RDP324	729						
RDP626	695						
RDP626	711						
RDP629	707						
RDP638	762						
RDP922	782						
RDP976	839						
RDP977	845						
RDP977	805						
RDP978	841						
SDP127	734						
SDP127	860						
SDP310	546						
SDP504	869						
SDP509	870						
SDP638	762						
SDP640	815						
SDP844	756						
SDP911	662						
SDP911	678						
SDP922	782						
SDP926	795						
SDP942	788						
SDP947	806						
SDP950	809						
SDP952	168						
SDP952	774						
SDP964	838						

Vesrah No.	SBS No.	Vesrah No.	SBS No.	Vesrah No.	SBS No.	Vesrah No.	SBS No.
VD-101	502	VD-165/3	156	VD-259	682	VD-348	635
VD-102	501	VD-165/3	735	VD-260	128	VD-349	686
VD-108	509	VD-165/4	880	VD-260	170	VD-350	701
VD-109	525	VD-166	894	VD-260	185	VD-351	122
VD-112	517	VD-166/2	734	VD-260	691	VD-351	702
VD-112/2	508	VD-167	784	VD-261	637	VD-352	705
VD-117	526	VD-168	777	VD-262	706	VD-353	146
VD-119	529	VD-169	158	VD-264	733	VD-353	740
VD-120	100	VD-170	809	VD-265	155	VD-354	788
VD-120	536	VD-171	813	VD-265	728	VD-355	806
VD-123	160	VD-172	192	VD-266	196	VD-356	174
VD-123	542	VD-172	828	VD-266	754	VD-357	182
VD-123/2	127	VD-173	193	VD-266/2	835	VD-358	820
VD-123/2	572	VD-174	834	VD-267	165	VD-359	833
VD-123/3	542	VD-175	829	VD-268	770	VD-412	514
VD-127	584	VD-177	180	VD-269	169	VD-413	522
VD-127	592	VD-177	797	VD-269/2	769	VD-414	510
VD-127/2	592	VD-178	862	VD-270	799	VD-420	539
VD-127/3	562	VD-178	892	VD-271	790	VD-420/2	540
VD-129	571	VD-179	869	VD-272	206	VD-423	530
VD-129/2	552	VD-180	205	VD-273	190	VD-425	113
VD-130	561	VD-181	859	VD-275	185	VD-425	135
VD-131	103	VD-181	228	VD-275	815	VD-425	546
VD-131	148	VD-182	784	VD-276	816	VD-425	586
VD-131	551	VD-182	915	VD-277	839	VD-425	651
VD-131	814	VD-185	892	VD-278	851	VD-425	684
VD-134	104	VD-186	216	VD-278/2	849	VD-425	692
VD-134	558	VD-187	940	VD-279	852	VD-426	557
VD-134/2	125	VD-204	504	VD-279/2	850	VD-427	597
VD-134/2	709	VD-205	507	VD-280	840	VD-428	602
VD-134/3	174	VD-215	528	VD-281	207	VD-430	615
VD-137	112	VD-216	545	VD-282	858	VD-432	632
VD-138	610	VD-222	617	VD-282	227	VD-432/2	648
VD-139	603	VD-228	547	VD-283	208	VD-434	687
VD-139/2	623	VD-234	576	VD-289	931	VD-435	704
VD-142	593	VD-235	550	VD-290	932	VD-435/2	886
VD-143	600	VD-236	555	VD-301	503	VD-435/2	920
VD-143/2	647	VD-239	107	VD-306	512	VD-436	715
VD-144	604	VD-239	575	VD-309	516	VD-436/2	765
VD-144	144	VD-240	570	VD-312	524	VD-437	676
VD-144/2	121	VD-241	580	VD-318	511	VD-437	729
VD-144/2	144	VD-242	590	VD-320	515	VD-437/2	779
VD-146	598	VD-242/2	613	VD-322	533	VD-438	726
VD-147	614	VD-242/3	590	VD-324	534	VD-439	778
VD-147/2	158	VD-244	589	VD-327	556	VD-440	752
VD-147/2	881	VD-245	596	VD-327/2	556	VD-441	801
VD-150	110	VD-246	616	VD-329	581	VD-442	798
VD-150	618	VD-247	111	VD-329/2	582	VD-443	782
VD-152	108	VD-247	619	VD-331	577	VD-444	838
VD-152	588	VD-248	198	VD-332	591	VD-9000	796
VD-154	622	VD-248	634	VD-340	197	VD-9001	802
VD-156	183	VD-248/2	198	VD-340	120	VD-9003	803
VD-156	212	VD-250	119	VD-340	611	VD-9004	189
VD-156	627	VD-250	134	VD-340/2	163	VD-9004	821
VD-156	630	VD-250	638	VD-340/2	713	VD-9006	783
VD-156/2	184	VD-250	688	VD-340/4	611	VD-9007	148
VD-156/2	630	VD-250/2	633	VD-341	649	VD-9007	652
VD-156/2	700	VD-250/2	688	VD-342	101	VD-9009	807
VD-156/3	181	VD-250/3	638	VD-342	544	VD-901	679
VD-156/3	654	VD-251	645	VD-342/2	102	VD-9010	808
VD-160	860	VD-252	137	VD-342/2	548	VD-9011	805
VD-161	694	VD-252/2	137	VD-343	624	VD-9012	140
VD-162	115	VD-253	659	VD-343/2	714	VD-9012	708
VD-162/2	209	VD-255	170	VD-344	631	VD-9013	173
VD-163	657	VD-255	663	VD-344/4	789	VD-9013	780
VD-164	685	VD-256	114	VD-345/2	620	VD-9015	192
VD-165	722	VD-256	667	VD-346	203	VD-9015	197
VD-165/2	721	VD-257	665	VD-346	585	VD-9015	774
VD-165/2	736	VD-258	683	VD-347	626	VD-9017	159

Vesrah No.	SBS No.	Vesrah No.	SBS No.	Vesrah No.	SBS No.	Vesrah No.	SBS No.
VD-9019	150	VD-934	640	VD-995	154		
VD-9022	826	VD-935	527	VD-995	746		
VD-9023	822	VD-936	621	VD-995	749		
VD-9024	800	VD-937	109	VD-996	141		
VD-9025	830	VD-937	607	VD-997	791		
VD-9026	210	VD-938	636	VD-998	763		
VD-9026	810	VD-939	643	VD-999	167		
VD-9027	677	VD-940	642	VD-999	773		
VD-9030	842	VD-941	644				
VD-9031	841	VD-942	608				
VD-9031	901	VD-943	601				
VD-9033	826	VD-944	678				
VD-9033	846	VD-944/2	662				
VD-9034	853	VD-945	566				
VD-9035	854	VD-946	105				
VD-9036	897	VD-946	188				
VD-9037	898	VD-946	559				
VD-9038	856	VD-947	151				
VD-9039	661	VD-947	194				
VD-904	505	VD-947	671				
VD-9044	195	VD-947/2	742				
VD-9045	201	VD-948	123				
VD-9045	204	VD-948/2	143				
VD-9045	847	VD-949	117				
VD-9046	866	VD-950	717				
VD-9047	867	VD-952	716				
VD-9048	864	VD-953	175				
VD-9049	899	VD-953	675				
VD-9050	905	VD-956	668				
VD-9050	906	VD-957	669				
VD-9052	844	VD-958	176				
VD-9053	870	VD-958	674				
VD-9056	191	VD-959	703				
VD-9057	904	VD-960	145				
VD-9058	885	VD-960	129				
VD-906	523	VD-961	707				
VD-906/2	698	VD-962	129				
VD-9060	908	VD-963	755				
VD-9061	911	VD-964	157				
VD-9062	910	VD-964	730				
VD-9063	872	VD-965	758				
VD-9068	877	VD-967/2	120				
VD-907	506	VD-967/2	168				
VD-9070	900	VD-967/2	774				
VD-9071	187	VD-968	142				
VD-9073	200	VD-968	202				
VD-9075	922	VD-969	695				
VD-9076	923	VD-969/2	711				
VD-908	537	VD-970	720				
VD-9082	934	VD-972	746				
VD-909	543	VD-973	757				
VD-910	520	VD-974	152				
VD-911	138	VD-974	747				
VD-911	519	VD-975	658				
VD-911/4	149	VD-976	153				
VD-912	532	VD-979	767				
VD-915	513	VD-979/2	836				
VD-917	553	VD-981	772				
VD-918	549	VD-981	166				
VD-919	579	VD-982	681				
VD-920	574	VD-983	177				
VD-924	594	VD-986	762				
VD-926	625	VD-987	171				
VD-927	641	VD-987	775				
VD-928	560	VD-991	794				
VD-931	606	VD-992	787				
VD-932	132	VD-993	795				
VD-932	595	VD-994	178				
VD-933	554	VD-994	792				

Ferodo No.	SBS No.	Ferodo No.	SBS No.	Ferodo No.	SBS No.	Ferodo No.	SBS No.
FDB88	505	FDB384	203	FDB697	607	FDB2086	174
FDB108	506	FDB384	585	FDB706	148	FDB2087	119
FDB118	502	FDB386	570	FDB706	652	FDB2087	134
FDB119	501	FDB389	577	FDB731	113	FDB2087	638
FDB120	503	FDB404	581	FDB731	541	FDB2087	688
FDB132	510	FDB411	580	FDB731	651	FDB2090	152
FDB134	509	FDB436	132	FDB736	640	FDB2090	747
FDB136	525	FDB436	595	FDB737	137	FDB2095	153
FDB150	511	FDB438	108	FDB754	657	FDB2096	154
FDB151	512	FDB438	588	FDB781	170	FDB2096	749
FDB155	520	FDB449	590	FDB781	663	FDB2100	117
FDB157	504	FDB452	600	FDB782	681	FDB2101	129
FDB177	507	FDB481	597	FDB828	684	FDB2102	746
FDB178	515	FDB485	668	FDB847	658	FDB2103	815
FDB181	514	FDB494	602	FDB864	683	FDB2105	159
FDB182	508	FDB495	603	FDB865	682	FDB2106	168
FDB182	517	FDB496	623	FDB866	672	FDB2106	774
FDB183	526	FDB497	163	FDB889	114	FDB2107	105
FDB184	528	FDB497	197	FDB889	667	FDB2107	559
FDB185	513	FDB497	611	FDB892	694	FDB2108	178
FDB202	527	FDB497	713	FDB2001	669	FDB2108	792
FDB204	554	FDB498	601	FDB2002	685	FDB2109	802
FDB205	560	FDB499	608	FDB2003	128	FDB2110	752
FDB207	138	FDB508	615	FDB2003	691	FDB2111	715
FDB207	519	FDB515	636	FDB2005	175	FDB2111	765
FDB213	532	FDB529	641	FDB2005	675	FDB2113	593
FDB217	534	FDB531	614	FDB2006	176	FDB2114	734
FDB218	533	FDB533	622	FDB2006	674	FDB2115	772
FDB220	530	FDB538	127	FDB2007	695	FDB2115	166
FDB244	160	FDB538	572	FDB2012	687	FDB2119	125
FDB244	542	FDB539	604	FDB2013	591	FDB2119	709
FDB247	545	FDB539	144	FDB2014	576	FDB2120	762
FDB248	522	FDB557	624	FDB2015	589	FDB2121	755
FDB250	100	FDB557	714	FDB2016	649	FDB2123	711
FDB250	536	FDB561	621	FDB2017	637	FDB2124	778
FDB250	643	FDB569	620	FDB2018	151	FDB2125	796
FDB277	547	FDB570	181	FDB2018	671	FDB2126	169
FDB298	540	FDB570	654	FDB2036	676	FDB2127	803
FDB299	539	FDB570	700	FDB2036	729	FDB2128	167
FDB310	552	FDB574	631	FDB2039	742	FDB2128	773
FDB310	571	FDB583	596	FDB2040	678	FDB2129	150
FDB311	550	FDB591	616	FDB2041	662	FDB2130	158
FDB312	103	FDB592	594	FDB2042	706	FDB2133	122
FDB312	200	FDB605	198	FDB2048	705	FDB2133	702
FDB312	551	FDB605	634	FDB2049	704	FDB2139	777
FDB312	814	FDB606	626	FDB2050	644	FDB2141	171
FDB313	102	FDB607	635	FDB2050	703	FDB2141	775
FDB313	101	FDB624	574	FDB2054	717	FDB2142	177
FDB313	544	FDB625	115	FDB2055	642	FDB2143	784
FDB313	548	FDB631	633	FDB2055	716	FDB2143	225
FDB314	135	FDB636	111	FDB2056	142	FDB2144	686
FDB314	546	FDB636	619	FDB2058	701	FDB2145	795
FDB314	586	FDB637	665	FDB2062	145	FDB2147	173
FDB314	692	FDB659	632	FDB2073	156	FDB2147	780
FDB333	537	FDB659	648	FDB2073	721	FDB2148	196
FDB334	543	FDB661	584	FDB2073	735	FDB2148	754
FDB335	549	FDB662	613	FDB2073	736	FDB2149	767
FDB336	553	FDB663	647	FDB2074	157	FDB2150	770
FDB337	555	FDB664	630	FDB2074	730	FDB2156	769
FDB338	556	FDB666	645	FDB2075	722	FDB2157	783
FDB339	557	FDB672	121	FDB2079	860	FDB2158	782
FDB342	523	FDB673	582	FDB2080	726	FDB2162	790
FDB352	579	FDB677	120	FDB2080	798	FDB2163	789
FDB381	562	FDB680	123	FDB2081	149	FDB2164	788
FDB381	592	FDB680	143	FDB2083	155	FDB2165	791
FDB382	104	FDB680	677	FDB2083	728	FDB2166	805
FDB382	558	FDB680	771	FDB2084	733	FDB2167	707
FDB383	107	FDB695	606	FDB2085	146	FDB2169	180
FDB383	575	FDB697	109	FDB2085	740	FDB2169	797

Ferodo No.	SBS No.	Ferodo No.	SBS No.	Ferodo No.	SBS No.	Ferodo No.	SBS No.
FDB2171	732	FDB2258	881				
FDB2173	182	FDB2259	869				
FDB2175	758	FDB2260	841				
FDB2176	787	FDB2262	885				
FDB2177	757	FDB2263	897				
FDB2178	806	FDB2264	208				
FDB2179	807	FDB2265	900				
FDB2180	808	FDB2266	877				
FDB2181	809	FDB2267	895				
FDB2182	813	FDB2271	907				
FDB2183	794	FDB2272	908				
FDB2184	810	FDB2273	911				
FDB2186	187	FDB2274	910				
FDB2187	183	FDB2275	915				
FDB2187	627	FDB2276	899				
FDB2188	801	FDB2277	224				
FDB2190	140	FDB2278	889				
FDB2190	708	FDB2279	221				
FDB2191	141	FDB2280	932				
FDB2192	110	FDB2281	892				
FDB2192	618	FDB2282	216				
FDB2193	799	FDB2284	207				
FDB2194	659	FRP202	569				
FDB2196	192	FRP408	566				
FDB2196	828	FRP410	599				
FDB2197	820	FRP410	661				
FDB2198	763	FRP415	656				
FDB2200	185	FRP418	660				
FDB2201	189						
FDB2201	821						
FDB2202	846						
FDB2206	861						
FDB2208	194						
FDB2210	830						
FDB2213	833						
FDB2216	844						
FDB2216	214						
FDB2217	839						
FDB2218	841						
FDB2219	840						
FDB2220	838						
FDB2221	834						
FDB2224	190						
FDB2226	201						
FDB2226	847						
FDB2228	845						
FDB2230	849						
FDB2231	850						
FDB2232	851						
FDB2233	852						
FDB2236	800						
FDB2238	858						
FDB2238	862						
FDB2238	227						
FDB2240	856						
FDB2241	857						
FDB2242	859						
FDB2242	228						
FDB2244	843						
FDB2245	842						
FDB2248	204						
FDB2250	853						
FDB2251	854						
FDB2252	864						
FDB2253	862						
FDB2254	195						
FDB2255	870						
FDB2256	205						
FDB2257	872						

Galfer No.	SBS No.	Galfer No.	SBS No.	Galfer No.	SBS No.	Galfer No.	SBS No.
002	503	086	611	149	115	234	153
004	502	087	613	150	647	245	159
005	501	089	608	152	117	251	746
008	523	090	597	153	123	252	203
009	504	091	602	154	682	252	585
012	138	092	603	155	685	254	752
012	519	093	144	156	686	259	784
013	506	093	604	157	683	260	169
014	510	094	102	159	672	261	154
016	517	094	548	159	672	261	749
017	507	095	100	160	656	262	762
018	505	095	536	161	655	263	166
019	513	096	593	162	120	263	772
022	512	097	589	163	659	265	783
025	509	098	594	164	694	267	715
028	560	099	624	165	175	270	167
031	532	100	622	165	675	270	773
035	511	101	626	166	129	271	796
036	520	102	636	167	687	272	778
037	525	103	614	168	695	275	171
038	515	104	615	169	128	275	775
039	527	105	569	169	691	277	177
042	625	107	631	171	114	278	777
044	554	108	183	171	667	284	125
045	526	108	627	172	176	284	709
046	533	109	620	172	674	286	790
047	534	110	623	173	660	290	788
048	574	111	556	174	705	291	791
051	547	112	630	175	141	295	769
052	540	113	110	176	706	297	173
054	160	113	618	177	122	297	780
054	542	114	648	177	702	298	180
056	550	116	606	178	198	298	797
057	555	117	134	178	634	299	584
058	537	117	638	179	704	300	717
059	543	118	601	182	756	301	755
060	552	119	641	186	742	302	758
061	553	120	635	187	163	303	716
062	557	121	645	187	713	304	843
063	104	122	105	188	140	314	649
063	558	122	559	188	708	315	196
064	549	124	579	189	701	315	754
065	105	125	668	193	676	316	757
065	559	126	669	194	715	317	787
066	577	127	616	196	715	318	767
067	528	128	621	198	703	319	801
068	566	129	137	200	142	320	799
069	570	130	598	204	726	321	798
070	582	131	644	205	721	322	800
071	132	132	681	206	145	323	813
071	595	133	148	207	722	325	806
072	596	133	652	208	711	326	809
073	103	134	657	209	581	329	770
073	551	135	684	214	155	331	782
074	108	136	111	214	728	334	187
074	588	136	619	216	699	336	810
075	135	137	640	218	733	339	807
075	546	138	151	219	734	340	808
076	562	138	671	220	157	341	189
077	545	139	677	220	730	341	821
078	620	140	181	222	146	342	190
079	107	140	654	222	740	343	191
079	575	142	170	223	802	344	192
080	580	142	663	224	803	344	828
082	600	143	665	225	815	345	193
084	109	144	121	228	152	352	185
084	607	145	119	228	747	353	822
085	601	145	688	230	794	355	194
086	197	148	622	232	149	359	833

Galfer No.	SBS No.	Galfer No.	SBS No.	Galfer No.	SBS No.	Galfer No.	SBS No.
362	820						
363	834						
364	840						
365	839						
367	214						
367	844						
369	830						
370	829						
371	838						
373	841						
375	826						
376	846						
378	850						
379	849						
380	852						
381	851						
384	676						
391	805						
392	759						
393	858						
397	856						
398	857						
399	847						
399	195						
400	847						
400	195						
401	182						
402	795						
404	898						
405	853						
406	854						
407	866						
408	867						
409	859						
410	773						
412	792						
412	178						
414	864						
428	895						
437	870						
438	204						
439	205						
441	872						
442	869						
443	862						
450	877						
456	861						
457	881						
458	885						
460	939						
473	208						
474	195						
475	900						
478	845						
484	932						
485	931						
486	763						
491	897						
499	940						
500	915						
503	226						
504	925						
504	216						
509	221						
512	892						







# **BRAKE PINS**

## **FITMENTS, DRAWINGS**



			Complete set		
<b>HONDA</b>					
CR	125 R	98 - 01	4000	4506	4505
CR	125 R	02 - 07	4001	4506	4508
CR	250 R	95 - 01	4000	4506	4505
CR	250 R	02 - 07	4001	4506	4508
CRF	250 R	04 - 09	4001	4506	4508
CRF	250 R Efi	10 - 17	4001	4506	4508
CRF	250 R Efi	18 -	4001	4506	4508
CRF	250 X	04 - 14	4001	4506	4508
CRF	450 R	02 - 08	4001	4506	4508
CRF	450 Efi	09 - 12	4001	4506	4508
CRF	450 R Efi	13 - 18	4001	4506	4508
CRF	450 RX Efi	17 - 18	4001	4506	4508
CRF	450 X	05 - 18	4001	4506	4508
<b>HUSQVARNA</b>					
CR	125	05 - 13	4003	4507	4510
TC	125	14 - 18	4003	4507	4510
TE	125	14 - 16	4003	4507	4510
TX	125	17 - 18	4003	4507	4510
CR	250	05	4003	4507	4510
FC	250	14 - 18	4003	4507	4510
FE	250	14 - 18	4003	4507	4510
TC	250	04 - 18	4003	4507	4510
TE	250	02 - 18	4003	4507	4510
TE	300	14 - 18	4003	4507	4510
FC	350	14 - 18	4003	4507	4510
FE	350	14 - 18	4003	4507	4510
TC	449	11 - 13	4003	4507	4510
FC	450	14 - 18	4003	4507	4510
FE	450	14 - 18	4003	4507	4510
TE	450	14	4003	4507	4510
FE	501	14 - 18	4003	4507	4510
TE	511	11 - 13	4003	4507	4510
<b>KAWASAKI</b>					
KX	125	95 - 96	4000	4506	4505
KX	125	97 - 08	4002	4509	4505
KX	250	95 - 96	4000	4506	4505
KX	250	97 - 08	4002	4509	4505
KX-F	250	04 - 10	4002	4509	4505
KX-F	250 DFI	11 - 18	4002	4509	4505
KX-F	450	06 - 08	4002	4509	4505
KX-F	450 DFI	09 - 18	4002	4509	4505
<b>KTM</b>					
EXC	125 Enduro	04 - 15	4003	4507	4510
SX	125	00 - 18	4003	4507	4510
SX	144	07 - 08	4003	4507	4510
SX	150	09 - 18	4003	4507	4510
EXC	200 Enduro	04 - 16	4003	4507	4510
SX	200	03 - 04	4003	4507	4510
EXC	250 Enduro	04 - 08	4003	4507	4510
EXC	250 Enduro 4T	04 - 06	4003	4507	4510
EXC	250 TPI	18 -	4003	4507	4510
EXC-F	250 Enduro	07 - 18	4003	4507	4510
SX	250	03 - 18	4003	4507	4510
SX-F	250	06 - 18	4003	4507	4510
XC	250	06 - 14	4003	4507	4510
EXC	300 Enduro	04 - 08	4003	4507	4510
EXC	300 TPI	18 -	4003	4507	4510
XC	300	06 - 14	4003	4507	4510
EXC-F	350	11 - 18	4003	4507	4510
SX-F	350	11 - 18	4003	4507	4510
XC-F	350	12 - 17	4003	4507	4510
EXC	400 Racing	00 - 07	4003	4507	4510
SX	400 Racing	00 - 02	4003	4507	4510
EXC-F	450 Racing	04 - 18	4003	4507	4510
SX-F	450	03 - 18	4003	4507	4510





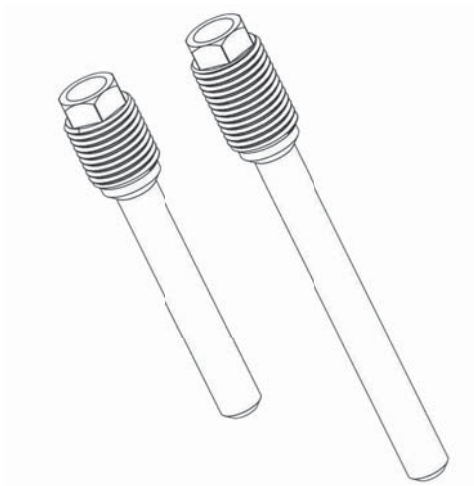

<b>KAWASAKI</b>					
KX	125	97 - 08	•		
KX	250	97 - 08	•		
KX-F	250	04 - 10	•		
KX-F	250 DFI	11 - 18	•		
KX-F	450	06 - 08	•		
KX-F	450 DFI	09 - 18	•		
<b>SUZUKI</b>					
RM-Z	250	04 - 06	•		

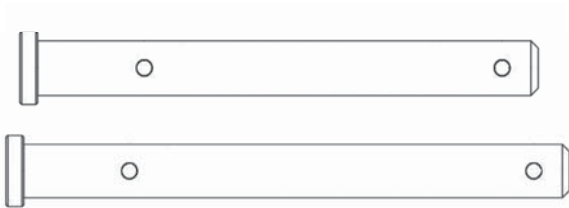

<b>HUSQVARNA</b>					
CR	125	05 - 13	•		
TC	125	14 - 18	•		
TE	125	14 - 16	•		
TX	125	17 - 18	•		
CR	250	05	•		
FC	250	14 - 18	•		
FE	250	14 - 18	•		
TC	250	04 - 18	•		
TE	250	02 - 18	•		
TE	300	14 - 18	•		
FC	350	14 - 18	•		
FE	350	14 - 18	•		
TC	449	11 - 13	•		
FC	450	14 - 18	•		
FE	450	14 - 18	•		
TE	450	14	•		
FE	501	14 - 18	•		
TE	511	11 - 13	•		
<b>KTM</b>					
EXC	125 Enduro	04 - 15	•		
SX	125	00 - 18	•		
SX	144	07 - 08	•		
SX	150	09 - 18	•		
EXC	200 Enduro	04 - 16	•		
SX	200	03 - 04	•		
EXC	250 Enduro	04 - 08	•		
EXC	250 Enduro 4T	04 - 06	•		
EXC	250 TPI	18 -	•		
EXC-F	250 Enduro	07 - 18	•		
SX	250	03 - 18	•		
SX-F	250	06 - 18	•		
XC	250	06 - 14	•		
EXC	300 Enduro	04 - 08	•		
EXC	300 TPI	18 -	•		
XC	300	06 - 14	•		
EXC-F	350	11 - 18	•		
SX-F	350	11 - 18	•		
XC-F	350	12 - 17	•		
EXC	400 Racing	00 - 07	•		
SX	400 Racing	00 - 02	•		
EXC-F	450 Racing	04 - 18	•		





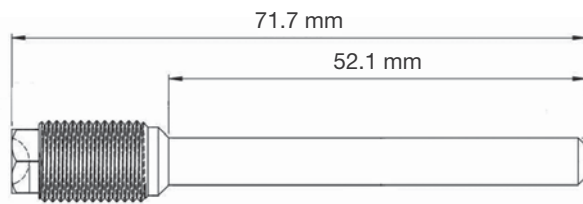

<b>YAMAHA</b>					
YZ	125	98 - 18			•
WR	250 F	03 - 13			•
WR	250 F Efi	17 - 18		•	•
WR	250 F Enduro GP	18 -		•	•
WR	250 X	08 - 16		•	•
YZ	250	98 - 18			•
YZ	250 F	01 - 13			•
YZ	250 F Efi	14 - 18			•
YZ	250 FX Efi	15			•
YZ	400	98			•
YZ	426 F	00 - 02			•
WR	450 F	03 - 15			•
WR	450 F Efi	16 - 18			•
WR	450 F Enduro GP	18 -		•	•
YZ	450 F	03 - 09			•
YZ	450 F Efi	10 - 17			•

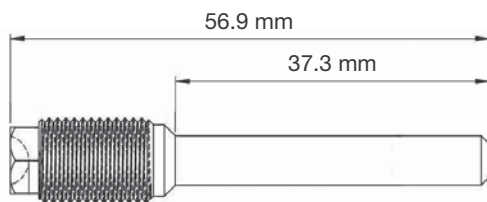

<b>HONDA</b>					
CR	125 R	98 - 07			•
CR	250 R	95 - 09			•
CRF	250 R	04 - 09			•
CRF	250 R Efi	10 - 17			•
CRF	250 R Efi	18 -			•
CRF	250 X	04 - 14			•
CRF	450 R	02 - 08			•
CRF	450 Efi	09 - 12			•
CRF	450 R Efi	13 - 18			•
CRF	450 RX Efi	17 - 18			•
CRF	450 X	05 - 18			•
<b>KAWASAKI</b>					
KX	125	95 - 96			•
KX	250	95 - 96			•
<b>SUZUKI</b>					
RM	125	99 - 09			•
RM	250	99 - 09			•
RM-Z	250	07 - 09			•
RM-Z	250 Efi	10 - 18			•
RM-Z	450	05 - 07			•
RM-Z	450 Efi	08 - 17			•
RM-Z	450 Efi	18 -			•
<b>YAMAHA</b>					
YZ	125	98 - 18			•
WR	250 F	03 - 13			•
YZ	250	98 - 18			•
YZ	250 F	01 - 13			•
YZ	250 F Efi	14 - 18			•
YZ	250 FX Efi	15			•
YZ	400	98			•
YZ	426 F	00 - 02			•
WR	450 F	03 - 15			•
WR	450 F Efi	16 - 18			•
YZ	450 F	03 - 09			•
YZ	450 F Efi	10 - 17			•



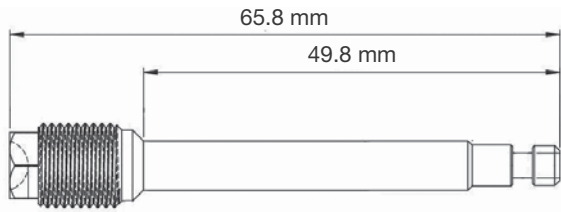

**HONDA**

CR	125 R	02 - 07			•
CR	250 R	02 - 07			•
CRF	250 R	04 - 09			•
CRF	250 R Efi	10 - 17			•
CRF	250 R Efi	18 -			•
CRF	250 X	04 - 14			•
CRF	450 R	02 - 08			•
CRF	450 Efi	09 - 12			•
CRF	450 R Efi	13 - 18			•
CRF	450 RX Efi	17 - 18			•
CRF	450 X	05 - 18			•

**SUZUKI**

RM	125	05 - 09			•
RM	250	05 - 09			•
RM-Z	250	08 - 09			•
RM-Z	250 Efi	10 - 18			•
RM-Z	450 Efi	08 - 17			•
RM-Z	450 Efi	18 -			•

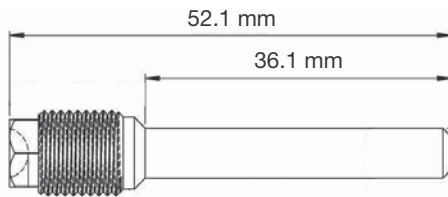

**KAWASAKI**

KX	125	97 - 08			•
KX	250	97 - 08			•
KX-F	250	04 - 10			•
KX-F	250 DFI	11 - 18			•
KX-F	450	06 - 08			•
KX-F	450 DFI	09 - 18			•

**SUZUKI**

RM-Z	250	04 - 06			•
------	-----	---------	--	--	---

















# CHOICE OF CHAMPIONS SINCE 2001

**CHOICE OF CHAMPIONS**

Michael Dunlop  
WINNER  
TT  
2011

ALL 1000cc TT  
WINNER SINCE 2007

2011  
2010  
2009  
2008  
2007

**sbs**  
THE POWER TO STOP YOU®

**CHOICE OF CHAMPIONS**

Michael Dunlop  
WINNER  
TT  
2010

2010  
2009  
2008  
2007

**sbs**  
THE POWER TO STOP YOU®

**CHOICE OF CHAMPIONS**

Ten Holmström  
WINNER  
TT  
2009

2009  
2008  
2007

**sbs**  
THE POWER TO STOP YOU®

**World Supersport Champion 2014**

SBS congratulates Paul Hanko  
"Maniac" Michael van der Mark  
with the 2014 World Supersport 600 title.

SBS 600 SS  
Dual Sinter

2014  
World Supersport 600 title

**sbs**  
THE POWER TO STOP YOU®

**TT Isle of Man**

Michael Dunlop  
WINNER  
TT  
2008

2008  
2007  
2006  
2005  
2004  
2003  
2002  
2001

**sbs**  
THE POWER TO STOP YOU®

**TT Isle of Man**

**sbs THE WINNING EDGE**

Michael Dunlop  
KING OF THE ROADS

2011  
2010  
2009  
2008  
2007  
2006  
2005  
2004  
2003  
2002  
2001

**sbs**  
THE POWER TO STOP YOU®

**2012**

**WORLD SUPERSPORT CHAMPION**  
Kenan Sofuoglu

2012  
2011  
2010  
2009  
2008  
2007  
2006  
2005  
2004  
2003  
2002  
2001

**sbs**  
THE POWER TO STOP YOU®

**sbs 2011**

**WORLD SUPERBIKE CHAMPION**  
Carlos Checa

2011  
2010  
2009  
2008  
2007  
2006  
2005  
2004  
2003  
2002  
2001

**sbs**  
THE POWER TO STOP YOU®

**2011 WORLD CHAMPIONS**

MX2 - Ken Flaxter  
MX1 - Antonio Cairoli

2011  
2010  
2009  
2008  
2007  
2006  
2005  
2004  
2003  
2002  
2001

**sbs**  
THE POWER TO STOP YOU®

**sbs 2010**

**WORLD SUPERSPORT CHAMPION**  
Kenan Sofuoglu

2010  
2009  
2008  
2007  
2006  
2005  
2004  
2003  
2002  
2001

**sbs**  
THE POWER TO STOP YOU®

**sbs Living Off-Road**

**2010 WORLD CHAMPIONS**

MX1 - Tony Cairoli  
MX2 - Marvin Musquin

2010  
2009  
2008  
2007  
2006  
2005  
2004  
2003  
2002  
2001

**sbs**  
THE POWER TO STOP YOU®

**2008**

**WORLD CHAMPION**  
Andrew Pitt  
SUPERSPORT 600

2008  
2007  
2006  
2005  
2004  
2003  
2002  
2001

**sbs**  
THE POWER TO STOP YOU®

**SBS #1 AGAIN!**

**2007 SUPERSPORT WORLD CHAMPION**  
Kenan Sofuoglu

2007  
2006  
2005  
2004  
2003  
2002  
2001

**sbs**  
THE POWER TO STOP YOU®

**DUAL CHAMPIONS**

**THE CHOICE OF 2007**  
WORLD CHAMPIONS

2007  
2006  
2005  
2004  
2003  
2002  
2001

**sbs**  
THE POWER TO STOP YOU®

**HIGH 5 FOR SBS!**

**ALL TOP 5 RIDERS**  
2006 World Supersport  
USED SBS BRAKE PADS!

2006  
2005  
2004  
2003  
2002  
2001

**sbs**  
THE POWER TO STOP YOU®

**CHOICE OF WORLD CHAMPIONS**

**2005**

2005  
2004  
2003  
2002  
2001

**sbs**  
THE POWER TO STOP YOU®

**CHOICE OF WORLD CHAMPIONS**

**2004**

2004  
2003  
2002  
2001

**sbs**  
THE POWER TO STOP YOU®

**WORLD CHAMPION!**

SBS congratulates  
Andrew Pitt (AUS) and  
Ten Kate Honda Racing Team  
winning the  
2003 World Supersport title.

2003  
2002  
2001

**sbs**  
THE POWER TO STOP YOU®

**World Champion!**

SBS congratulates  
Chris Vermeulen &  
Andrew Pitt (AUS) and  
Team Eckl Kawasaki Racing  
with the 2001  
World Supersport 600 title.

2001  
2000  
1999  
1998  
1997  
1996  
1995  
1994  
1993  
1992  
1991

**sbs**  
THE POWER TO STOP YOU®

**sbs**  
THE POWER TO STOP YOU®

**BRAKE PADS FOR ALL YOUR POWERSPORT NEEDS - MADE IN DENMARK**





# HI-TECH BRAKE SOLUTIONS MADE IN EUROPE

At SBS, we develop and manufacture hi-tech brake solutions.

Our ranges of brake pads, brake discs, brake shoes and other important parts cover all relevant motorcycles, scooters and ATV/UTVs on the market, regardless of make and model. SBS is your single source for brake parts and components.

We are a global market leader within brakes for powered two-wheelers. Our R&D department continuously innovates with new materials and technologies to achieve ultimate performance, longer lifetime, higher comfort and more eco-friendly products.

Our products are tested by reality. Dynamometer testing is supplemented with numerous street and race track tests. We work with some of the world's best road racing and motocross riders, when they race towards podium positions.

We create the power to stop you. Made in Europe. You decide where and how to use it. Go Ahead!

